

200 A 25 kV class insulated protective cap



General

Eaton's Cooper Power™ series insulated protective cap is an accessory device designed to electrically insulate and mechanically seal loadbreak bushing interfaces. When mated to a loadbreak product and the drain wire is attached to ground, the insulated protective cap provides a fully shielded, submersible insulating cover for energized bushings. The cap can be used for permanent or temporary installation on bushings, junctions, or feedthru devices that meet the requirements of IEEE Std 386™-2006 standard.

Installation

No special tools are required. A clampstick tool is used to place the protective cap on an exposed bushing interface. Refer to *Service Information MN650013EN, 200 A 15 and 25 kV Class Insulated Protective Cap Installation Instructions* for details.

Production tests

Tests are conducted in accordance with IEEE Std 386™-2006 standard.

- AC 60 Hz 1 Minute Withstand
 - 40 kV
- Minimum Corona Voltage Level
 - 19 kV

Tests are conducted in accordance with Eaton requirements.

- Physical Inspection
- Periodic Dissection
- Periodic Fluoroscopic Analysis

Table 1. Voltage Ratings and Characteristics

Description	kV
Standard Voltage Class	25
Maximum Rating Phase-to-Phase	26.3
Maximum Rating Phase-to-Ground	15.2
AC 60 Hz 1 Minute Withstand	40
DC 15 Minute Withstand	78
BIL and Full Wave Crest	125
Minimum Corona Voltage Level	19

Voltage ratings and characteristics are in accordance with IEEE Std 386™-2006 standard..

Ordering information

To order the 25 kV Class Insulated Protective Cap Kit, refer to Table 2.

Table 2. Insulated Protective Cap Kit

Description	Catalog Number
Protective Cap	LPC 225

Each kit contains:

- Protective Cap with stranded copper ground wire
- Silicone Lubricant
- Installation Instruction Sheet

Features and detailed description

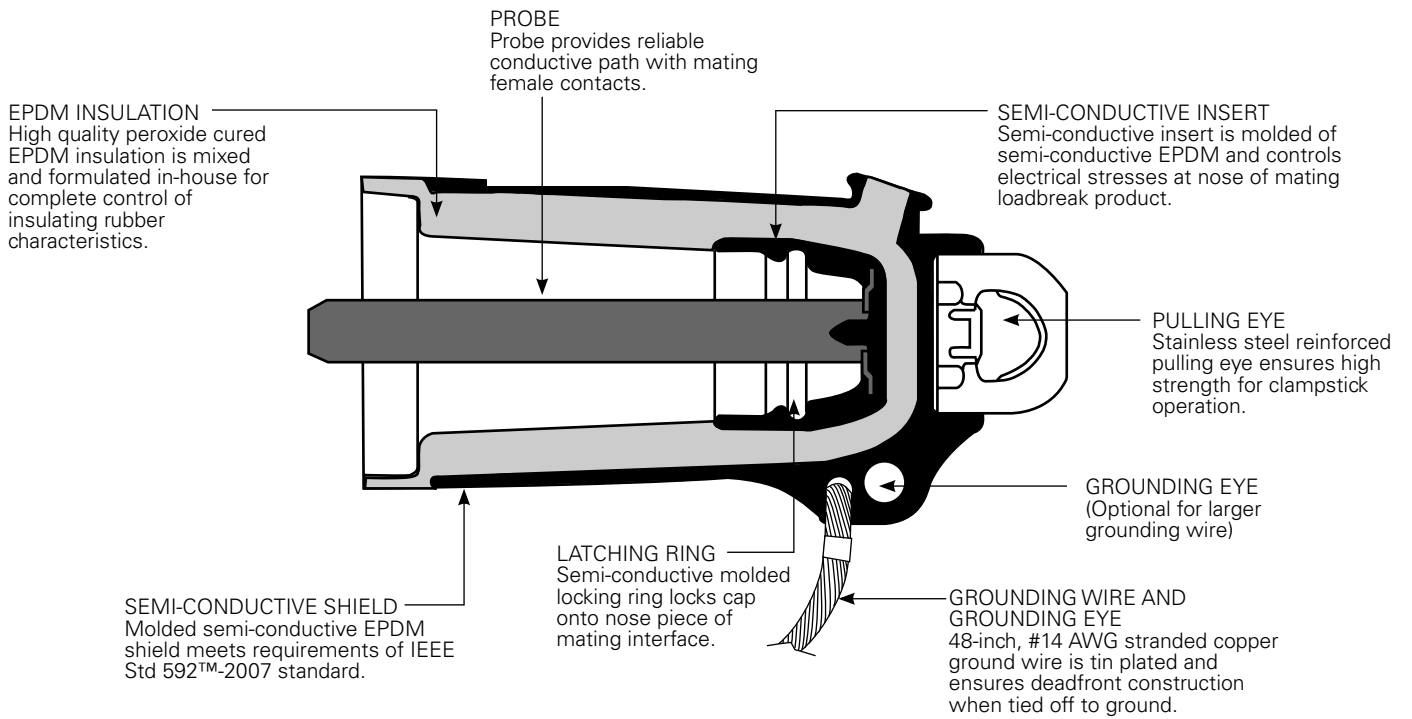

Figure 1. Illustration shows construction of insulated protective cap.

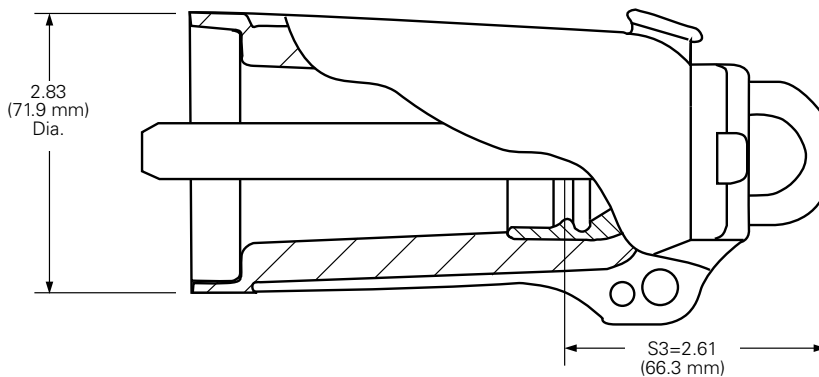

Figure 2. Insulated protective cap profile and stacking dimensions.

Eaton
1000 Eaton Boulevard
Cleveland, OH 44122
United States
Eaton.com

Eaton's Cooper Power Systems Division
2300 Badger Drive
Waukesha, WI 53188
United States
Eaton.com/cooperpowerseries

© 2015 Eaton
All Rights Reserved
Printed in USA
Publication No. CA650085EN

Eaton is a registered trademark.
All other trademarks are property
of their respective owners.

For Eaton's Cooper Power series product
information call 1-877-277-4636 or visit:
www.eaton.com/cooperpowerseries.