

# 200 A 25 kV class POSI-BREAK™ insulated protective cap



## General

Eaton's Cooper Power™ series POSI-BREAK™ insulated protective cap is an accessory device designed to electrically insulate and mechanically seal loadbreak bushing interfaces. When mated to a loadbreak product and the drain wire is attached to ground, the POSI-BREAK insulated protective cap provides a fully shielded, submersible insulating cover for energized bushings. The cap can be used for installations on bushings, junctions or feedthru devices that meet the requirements of IEEE Std 386™-2006 standard.

This cap design uses a state-of-the-art manufacturing process that creates an insulated sleeve around the top of the copper probe. It also provides a layer of insulating peroxide-cured EPDM rubber over the peroxide-cured conductive internal insert of the cap. This added insulation greatly increases the strike distance and improves the dielectrics. This increased performance reduces the potential for partial vacuum flashovers while maintaining the stress relieving Faraday Cage that is critical to long term field performance.

## Installation

No special tools are required. A clampstick is used to place the protective cap on an exposed bushing interface. Refer to *Service Information MN650013EN, 200 A 15, 25, and 35 kV Class Insulated Protective Cap Installation Instructions* for details.

## Production tests

Tests conducted in accordance with IEEE Std 386™-2006 standard:

- ac 60 Hz 1 Minute Withstand
  - 40 kV
- Minimum Corona Voltage Level
  - 19 kV

Tests conducted in accordance with Eaton requirements:

- Physical Inspection
- Periodic Dissection
- Periodic Fluoroscopic (X-ray) Analysis

**Table 1. Voltage Ratings and Characteristics**

Description	kV
Standard Voltage Class	25
Maximum Rating Phase-to-Phase	26.3
Maximum Rating Phase-to-Ground	15.2
AC 60 Hz 1 Minute Withstand	40
DC 15 Minute Withstand	78
BIL and Full Wave Crest	125
Minimum Corona Voltage Level	19

Voltage ratings and characteristics are in accordance with IEEE Std 386™-2006 standard.

## Ordering information

To order the 25 kV Class POSI-BREAK Insulated Protective Cap Kit, refer to Table 2.

**Table 2. Insulated Protective Cap Kit**

Description	Catalog #
Protective Cap, 30 Kit Bulk Pack	PLPC225
Protective Cap, Individually Boxed Kit	PLPC225X

Each kit contains:

- Protective Cap with stranded copper ground wire
- Silicone Lubricant
- Installation Instruction Sheet

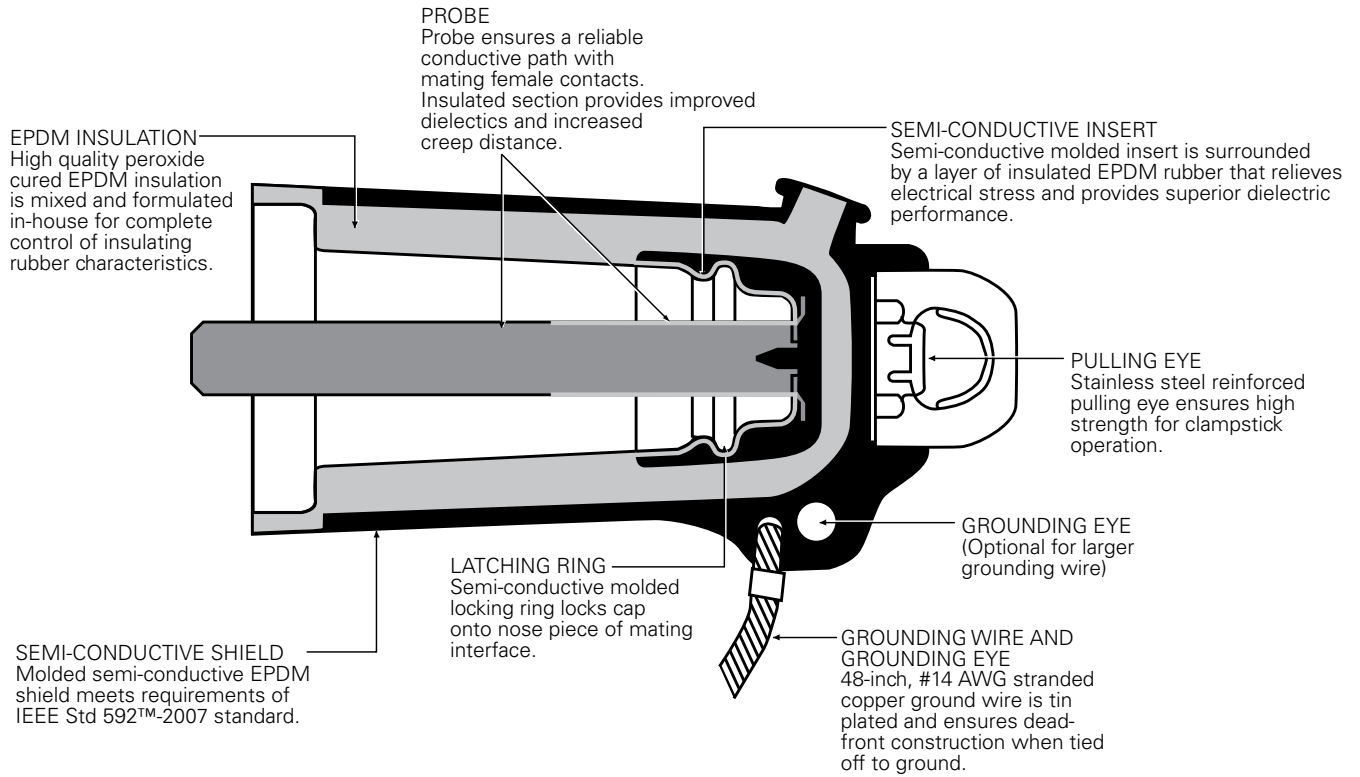

Figure 1. Illustration shows construction of POSI-BREAK insulated protective cap with insulated probe and insert.

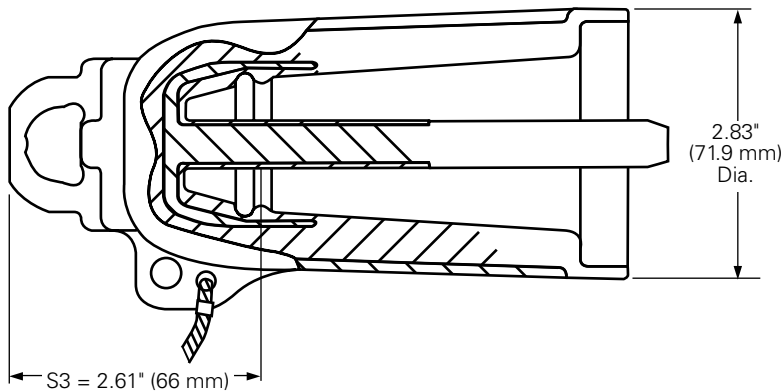

Figure 2. POSI-BREAK insulated protective cap profile and stacking dimensions.

**Eaton**  
1000 Eaton Boulevard  
Cleveland, OH 44122  
United States  
Eaton.com

**Eaton's Cooper Power Systems Division**  
2300 Badger Drive  
Waukesha, WI 53188  
United States  
Eaton.com/cooperpowerseries

© 2015 Eaton  
All Rights Reserved  
Printed in USA  
Publication No. CA650083EN

Eaton is a registered trademark.  
All other trademarks are property  
of their respective owners.

For Eaton's Cooper Power series product  
information call 1-877-277-4636 or visit:  
[www.eaton.com/cooperpowerseries](http://www.eaton.com/cooperpowerseries).