

200 A 25 and 28 kV class POSI-BREAK™ loadbreak elbow connector with optional integral jacket seal-Canadian Edition



General

Eaton's Cooper Power™ series POSI-BREAK™ loadbreak elbow connector is a fully-shielded and insulated plug-in termination for connecting underground cable to transformers, switching cabinets and junctions equipped with loadbreak bushings. The POSI-BREAK elbow is a fully rated 200 A switching device, designed in accordance to the IEEE Std 386™-2006 standard.

The elbow design uses a state of the art manufacturing process that creates an insulated sleeve around the top of the copper probe. It also provides a layer of insulating rubber over the conductive internal insert of the elbow. This leaves the stress relieving feature around the current interchange intact and furnishes improved dielectrics and increased strike distance. Together these features provide superior switching performance and reliability.

Eaton's loadbreak elbows are molded using high quality peroxide-cured EPDM rubber. Standard kit features include a coppertop connector, tin-plated copper loadbreak probe with an ablative arc-follower tip and a stainless steel reinforced pulling-eye. An optional capacitive test point, made of corrosion resistant plastic, is available for use with fault indicators (see Catalog Data CA320002EN and CA320003EN).

Cable ranges are designed to accept a wide range of cable conductor and insulation sizes with just three elbows and accommodate cable manufactured to either AEIC or ICEA standards.

The coppertop compression connector is a standard item to transition from the cable to the loadbreak probe. An aluminum crimp barrel is inertia-welded to a copper lug. The aluminum barrel makes the connector easy to crimp and the copper lug ensures a reliable, tight, cool operating connection with the loadbreak probe. Shown at far left is the loadbreak elbow connector with optional integral jacket seal and without test point; to its right is the loadbreak elbow without jacket seal and with test point.

Photo on the left is the loadbreak elbow connector with optional integral jacket seal and without test point. The photo on the right is the loadbreak elbow without the jacket seal and with test point.

EATON

Powering Business Worldwide

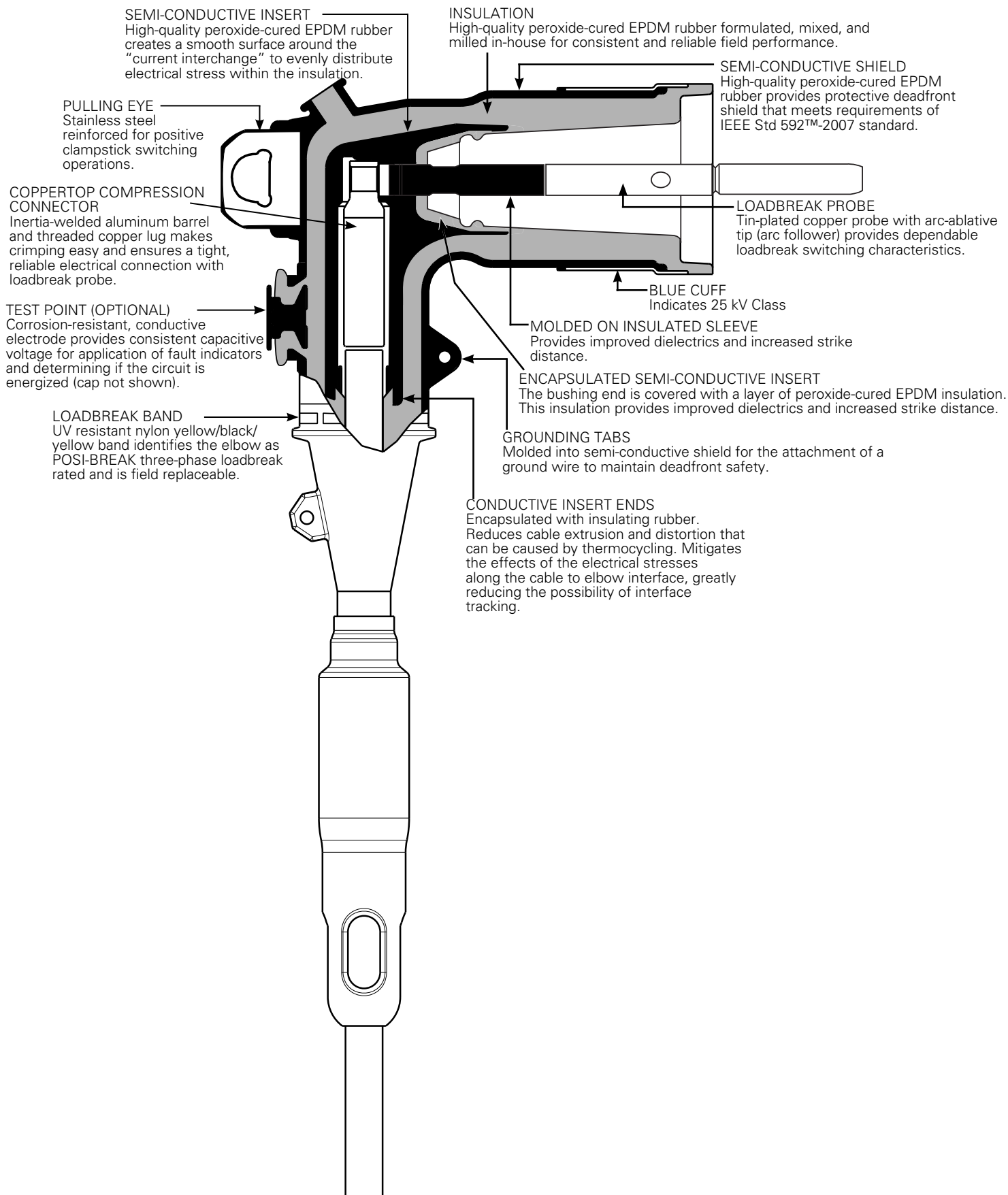
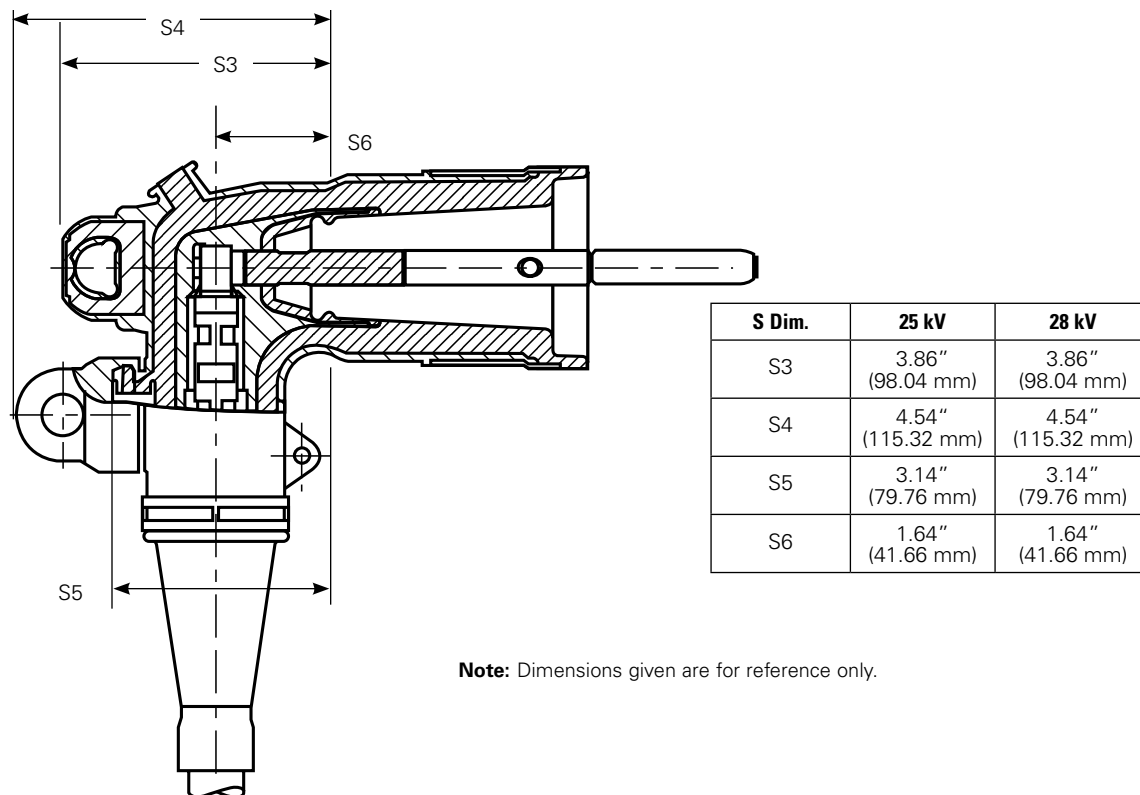

Figure 1. POSI-BREAK elbow cutaway drawing illustrates design detail.



Note: Dimensions given are for reference only.

Figure 2. POSI-BREAK elbow profile and stacking dimensions as referenced in IEEE Std 386™-2006 standard.

Retrofit

The POSI-BREAK elbow can be used to upgrade or replace existing elbows without having to re-strip the medium-voltage cable.

See *Service Information MN650008EN 200 A 15 kV and 25 kV Class Elbow with Optional Integral Jacket Seal Installation Instructions* for retrofit and installation details.

Optional integral jacket seal

The optional integral jacket seal provides a quick and easy means of sealing the cable jacket to prevent moisture ingress. Our jacket seal is molded to the loadbreak elbow eliminating the need for separate cable sealing products. It's available with braided ground strap/bleeder wire for terminating Tape shielded cable. (See Figure 4.)

Installation

Cable stripping and scoring tools, available from various tool manufacturers, are recommended for use when installing loadbreak elbows. After preparing the cable, the elbow housing is pushed onto the cable. The loadbreak probe is threaded into the copper-top connector using the supplied installation tool or an approved equivalent. Use a clampstick to perform loadmake and loadbreak operations. Refer to *Service Information MN650008EN 200 A 15 kV and 25 kV Class Elbow with Optional Integral Jacket Seal Installation Instructions* for details.

Operating interface AC withstand test

POSI-BREAK elbows and caps have successfully passed the "Operating Interface AC Withstand Test" to the more stringent Option B at 30 kV test level. This test, Annex B of IEEE Std 386™-2006 standard, ensures that POSI-BREAK will eliminate partial vacuum related flashovers in the field.

Production tests

Tests conducted in accordance with IEEE Std 386™-2006 standard:

- AC 60 Hz 1 Minute Withstand
 - 25 kV = 40 kV
 - 28 kV = 45 kV
- Minimum Corona Voltage Level
 - 25 kV = 19 kV
 - 28 kV = 21.5 kV
- Test Point Voltage Test

Tests conducted in accordance with Eaton requirements:

- Physical Inspection
- Periodic Dissection
- Periodic Fluoroscopic Analysis

Table 1. Voltage Ratings and Characteristics

Description	25 kV	28 kV
Standard Voltage Class	25	28
Maximum Rating Phase-to-Phase	26.3	28
Maximum Rating Phase-to-Ground	15.2	16.2
AC 60 Hz 1 Minute Withstand	40	45
DC 15 Minute Withstand	78	100
BIL and Full Wave Crest	125	125
Minimum Corona Voltage Level	19	21.5

Voltage ratings and characteristics are in accordance with IEEE Std 386™-2006 standard

Table 2. Current Ratings and Characteristics

Description	25 kV
Continuous	200 A rms
Switching	10 operations at 200 A rms at 26.3 kV
Fault Closure	10,000 A rms symmetrical at 26.3 kV for 0.17 s after 10 switching operations
Short Time	10,000 A rms symmetrical for 0.17 s
	3,500 A rms symmetrical for 3.0 s
Description	28 kV
Continuous	200 A rms
Switching	10 operations at 200 A rms at 28.0 kV
Fault Closure	10,000 A rms symmetrical at 28.0 kV for 0.17 s after 10 switching operations
Short Time	10,000 A rms symmetrical for 0.17 s
	3,500 A rms symmetrical for 3.0 s

Current ratings and characteristics are in accordance with IEEE Std 386™ -2006 standard.

Ordering information

The POSI-BREAK elbow kits are packaged in a heavy duty polyethylene bag. There are 20 bagged kits to a carton. Individual boxed kits are also available by special part number. To order a 25 or 28 kV Class POSI-BREAK Loadbreak Elbow Kit follow the easy steps below.

Each kit contains:

- Standard Elbow Body or Elbow Body with Jacket Seal
- Coppertop Compression Connector
- Loadbreak Probe
- Probe Installation Tool
- Silicone Lubricant
- Mastic Strips (**Jacket Seal Elbow Only**)
- Installation Instruction Sheet

STEP 1: Select required kV rating:

25 kV, PLE225

28 kV, PLE228

STEP 2: Determine the cable's diameter over the electrical insulation as shown in Figure 3 (including tolerances) from cable manufacturer. Then identify a cable range from Table 3 that brackets the minimum and maximum insulation diameters. Select the CABLE RANGE CODE from the far right column.

STEP 3: Identify the conductor size and type from **Table 4** for **Standard** IEEE compression connectors

OR

Table 5 for **CSA** compression connectors

AND

Select the CONDUCTOR CODE from the far right column.

STEP 4: For a POSI-BREAK elbow kit with a capacitive test point order:

PLE225 PLE228	CABLE RANGE CODE	CONDUCTOR CODE	T
------------------	---------------------	-------------------	---

For a POSI-BREAK elbow kit with integral jacket seal and capacitive test point order:

PLEJ225 PLEJ228	CABLE RANGE CODE	CONDUCTOR CODE	T
--------------------	---------------------	-------------------	---

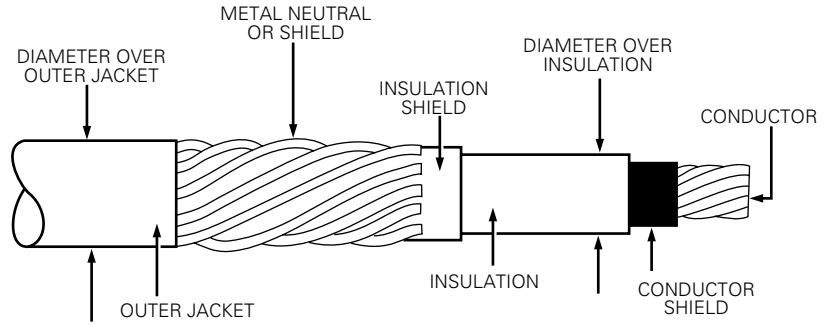

Figure 3. Illustration showing typical construction of medium voltage underground cable.

For a POSI-BREAK elbow kit without a capacitive test point order:

PLE225 PLE228	CABLE RANGE CODE	CONDUCTOR CODE
------------------	---------------------	-------------------

For a POSI-BREAK elbow kit with integral jacket seal without a capacitive test point order:

PLEJ225 PLEJ228	CABLE RANGE CODE	CONDUCTOR CODE
--------------------	---------------------	-------------------

For a POSI-BREAK elbow kit without a compression connector, use "00" for the conductor code.

STEP 5: For an elbow where a **CSA** connector was selected in Step 2, add "**CSA**" after the test point/no test point option.

STEP 6: For optional braided ground strap/bleeder wire for terminating tape shielded cable, Insert "**GS**" after test point and CSA option code. (**Integral Jacket Seal Elbow Only**)

STEP 7: (Optional) For a POSI-BREAK elbow kit individually packaged in a corrugated cardboard box, insert an "**X**" as the last character in the part number.

Table 3. Cable insulation diameter range

Inches	Millimeters	Cable Range Code
0.610" - 0.970"	15.5 - 24.6	AB
0.750" - 1.080"	19.1 - 27.4	CC
0.890" - 1.220"	22.6 - 30.0	DD

Table 4. Conductor Size and Type

Class B Stranded or Compressed		Compact or Solid		Conductor Code
AWG	mm ²	AWG	mm ²	
No Connector				00
#6	16	#4	–	01
#4	–	#3	25	02
#3	25	#2	35	03
#2	35	#1	–	04
#1	–	1/0	50	05
1/0	50	2/0	70	06
2/0	70	3/0	–	07
3/0	–	4/0	95	08
4/0	95	250	120	09
250*	120	300	–	10

* Compressed stranding only.

Note: Coppertop compression connector may be used on both aluminum and copper cable conductors.

Table 5. CSA Compression Connectors

Conductor Size and Type

Stranded				
Concentric, Compressed or Compact		Solid		Conductor Code
AWG	mm ²	AWG	mm ²	
No Connector				00
#6	16	#4	–	01
#4	–	#3	–	02
#3	–	#2	25	03
#2	25	#1	35	04
#1	35	1/0	50	05
1/0	50	2/0	70	06
2/0	70	3/0	–	07
3/0	–	–	–	08
4/0	95	–	–	09

EXAMPLE: Select a 28 kV integral jacket seal POSI-BREAK elbow kit with CSA connector and capacitive test point for use on a #1 compact cable with a minimum insulation diameter of 0.770" and a maximum diameter of 0.830".

STEP 1: From Table 3, identify the cable range 0.750–1.080" and select the **"AB"** CABLE RANGE CODE.

STEP 2: The conductor size is a #1 and the type is compact. **CSA** style connector required.

From Table 5, under the column "Stranded" identify #1 and select the **"05"** conductor code.

STEP 3: Order catalog number.

LEJ228CC05TCSA

Table 6. Replacement CSA Coppertop Compression Connectors

Conductor Size				
Concentric, Compressed or Compact		Solid		Catalog Number
AWG	mm ²	AWG	mm ²	
#6	16	#4	—	CC2C01TCSA
#4	—	#3	—	CC2C02TCSA
#3	—	#2	25	CC2C03TCSA
#2	25	#1	35	CC2C04TCSA
#1	35	1/0	50	CC2C05TCSA
1/0	50	2/0	70	CC2C06TCSA
2/0	70	3/0	—	CC2C07TCSA
3/0	—	—	—	CC2C08TCSA
4/0	96	—	—	CC2C09TCSA

* Compressed stranding only.

Note: Coppertop compression connector may be used on both aluminum and copper cable conductors.

Table 7. Replacement Parts

Description	Catalog Number
Hold Down Bail Assembly	2638351C01B
Loadbreak Probe Installation Tool	2602733A01
Probe Kit (includes Insulated Probe, Installation Tool, Silicone Lubricant, Installation Instruction Sheet)	PKPB228
Silicone Grease	
0.175 oz tube (5 grams)	2603393A03
5.3 oz tube (150 grams)	2605670A02M
Test Point Cap	2639992A01
Includes Ground Braid, Constant Force Spring and Mastic	GRDBRAIDKIT

Accessories



Figure 4. Braided ground strap kit.

Eaton
1000 Eaton Boulevard
Cleveland, OH 44122
United States
Eaton.com

Eaton's Power Systems Division 2300
Badger Drive
Waukesha, WI 53188
United States
Eaton.com/cooperpowerseries

© 2019 Eaton
All Rights Reserved
Printed in USA
Publication No. CA650101EN
March 2019

Eaton is a registered trademark.

All other trademarks are property
of their respective owners.

For Eaton's Cooper Power series product
information call 1-877-277-4636 or visit:
www.eaton.com/cooperpowerseries.