

# 200 A 25 kV and 28 kV class loadbreak elbow connector with optional integral jacket seal-Canadian Edition

## General

Eaton's Cooper Power™ series loadbreak elbow connector is a fully-shielded and insulated plug-in termination for connecting underground cable to transformers, switching cabinets and junctions equipped with loadbreak bushings. The elbow connector and bushing insert comprise the essential components of all loadbreak connections. The elbow connector is a fully rated 200 A switching device, designed in accordance to IEEE Std 386™-2006 standard.

Loadbreak elbows are molded using high quality peroxide-cured insulating and semi-conducting EPDM rubber. Standard features include a coppertop connector, tin-plated copper loadbreak probe with an ablative arc-follower tip and stainless steel reinforced pulling-eye. An optional capacitive test point, made of corrosion resistant plastic, is available for use with fault indicators (see Catalog Data CA320002EN and CA320003EN).

Cable ranges are designed to accept a wide range of cable conductor and insulation sizes with just three elbows and accommodate cable manufactured to either AEIC or ICEA standards.

The coppertop compression connector is a standard item to transition from the cable to the loadbreak probe. An aluminum crimp barrel is inertia-welded to a copper lug. The aluminum barrel makes the connector easy to crimp and the copper lug ensures a reliable, tight, cool operating connection with the loadbreak probe. Shown at far left is the loadbreak elbow connector with optional integral jacket seal and without test point; to its right is the loadbreak elbow without jacket seal and with test point.

## Optional integral jacket seal

The optional integral jacket seal provides a quick and easy means of sealing the cable jacket to prevent moisture ingress. Our jacket seal is molded to the loadbreak elbow eliminating the need for separate cable sealing products. It's available with braided ground strap/bleeder wire for terminating Tape shielded cable. (See Figure 4.)

Shown at left is the loadbreak elbow connector with optional integral jacket seal and without test point. On the right is the loadbreak elbow without jacket seal and with test point.



**EATON**

Powering Business Worldwide

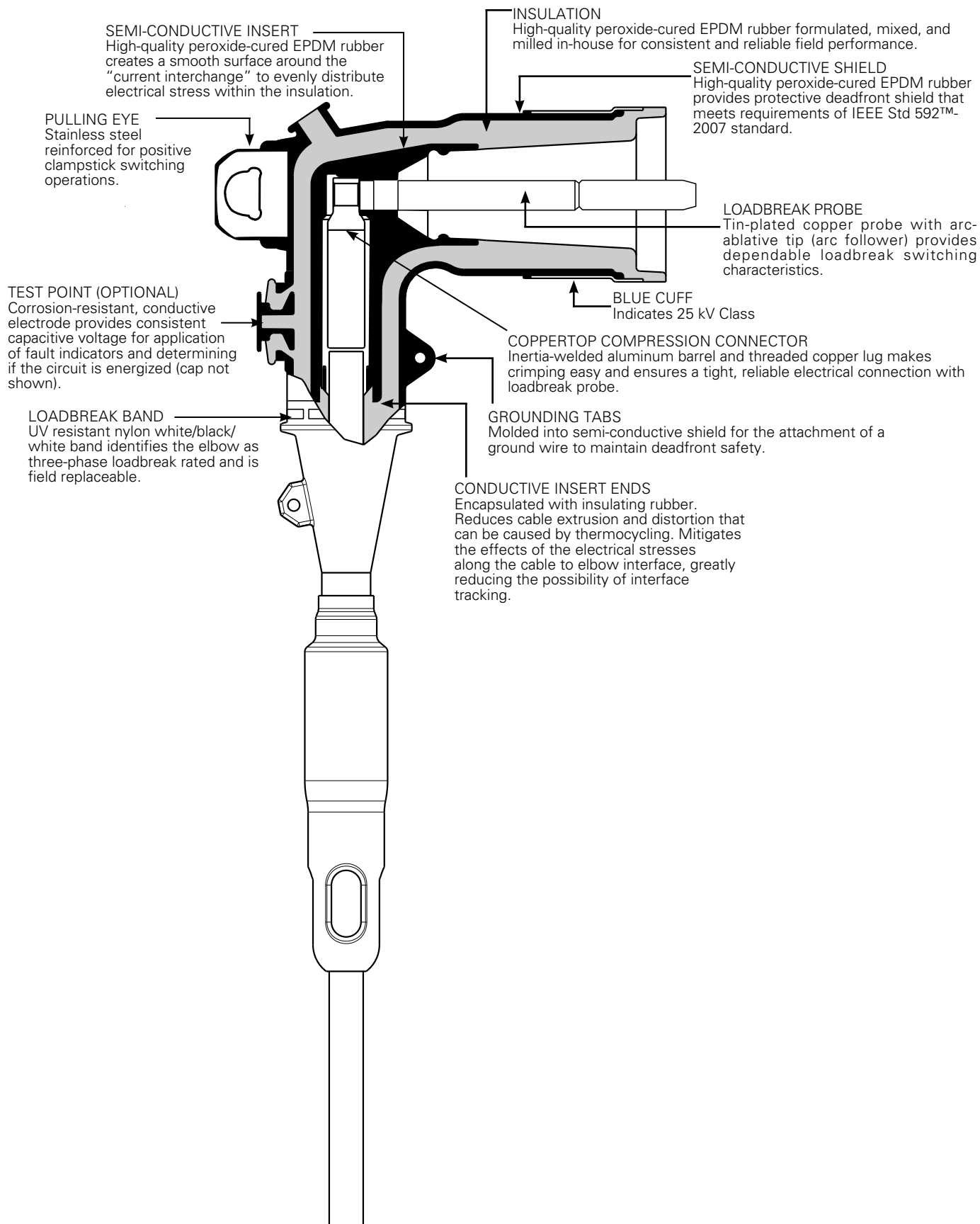
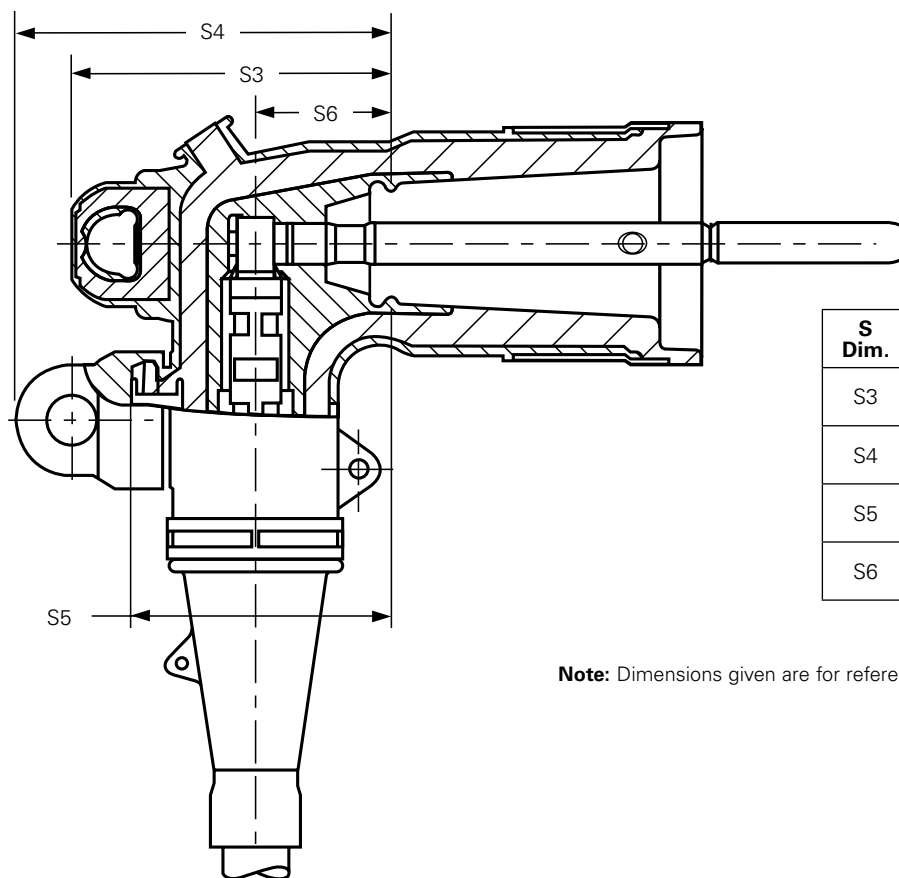

Figure 1. Elbow cutaway illustrates design features.



S Dim.	25 kV	28 kV
S3	3.86" (98.04 mm)	3.86" (98.04 mm)
S4	4.54" (115.32 mm)	4.54" (115.32 mm)
S5	3.14" (79.76 mm)	3.14" (79.76 mm)
S6	1.64" (41.66 mm)	1.64" (41.66 mm)

**Note:** Dimensions given are for reference only.

**Figure 2. Elbow profile and stacking dimensions as referenced in IEEE Std 386™-2006 standard.**

## Installation

Cable stripping and scoring tools, available from various tool manufacturers, are recommended for use when installing loadbreak elbows. After preparing the cable, the elbow housing is pushed onto the cable. The loadbreak probe is threaded into the coppertop connector using the supplied installation tool or an approved equivalent. Use a clampstick to perform loadmake and loadbreak operations. Refer to *Service Information MN650008EN 200 A 15 kV and 25 kV Class Elbow with Optional Integral Jacket Seal Installation Instructions* for details.

## Production tests

Tests conducted in accordance with IEEE Std 386™-2006 standard:

- AC 60 Hz 1 Minute withstand
  - 25 kV=40 kV
  - 28 kV=45 kV
- Minimum corona voltage level
  - 25 kV=19 kV
  - 28 kV=21.5
- Test point voltage test

Tests conducted in accordance with Eaton requirements:

- Physical inspection
- Periodic dissection
- Periodic fluoroscopic analysis

**Table 1. Voltage ratings and characteristics**

Description	25 kV	28 kV
Standard Voltage Class	25	28
Maximum Rating Phase-to-Phase	26.3	28
Maximum Rating Phase-to-Ground	15.2	16.2
AC 60 Hz 1 Minute Withstand	40	45
DC 15 Minute Withstand	78	100
BIL and Full Wave Crest	125	125
Minimum Corona Voltage Level	19	21.5

Voltage ratings and characteristics are in accordance with IEEE Std 386™-2006 standard.

**Table 2. Current ratings and characteristics**

Description	25 kV	28 kV
Continuous	200 A rms	200 A rms
Switching	10 operations at 200 A rms at 26.3 kV	10 operations at 200 A rms at 28.0 kV
Fault Closure	10,000 A rms symmetrical at 26.3 kV for 0.17 s after 10 switching operations	10,000 A rms symmetrical at 28.0 kV for 0.17 s after 10 switching operations
Short Time	10,000 A rms symmetrical for 0.17 s 3,500 A rms symmetrical for 3.0 s	10,000 A rms symmetrical for 0.17 s 3,500 A rms symmetrical for 3.0 s

Current ratings and characteristics are in accordance with IEEE Std 386™-2006 standard.

### Ordering information

The elbow kits are packaged in a heavy duty polyethylene bag. There are 20 bagged kits to a carton. Individual boxed kits are also available by special part number. To order a 25 kV or 28 kV Class Loadbreak Elbow Kit follow the easy steps below.

Each kit contains:

- Standard elbow body or elbow body with jacket seal
- Coppertop compression connector
- Loadbreak probe
- Probe installation tool
- Silicone lubricant
- Mastic strips (Jacket seal elbow only)
- Installation instruction sheet

**STEP 1:** Select required kV rating:

**25 kV, LE225**

**28 kV, LE228**

**STEP 2:** Determine the cable's diameter over the electrical insulation as shown in Figure 3 (including tolerances) from cable manufacturer. Then identify a cable range from Table 3 that brackets the minimum and maximum insulation diameters. Select the CABLE RANGE CODE from the far right column.

**STEP 3:** Identify the conductor size and type in **Table 4** for **Standard** IEEE compression connectors

**OR**

**Table 5** for **CSA** compression connectors

**AND**

Select the CONDUCTOR CODE from the far right column.

**STEP 4:** For an elbow kit with a capacitive test point order:



For an elbow kit with integral jacket seal and capacitive test point order:



For an elbow kit without a capacitive test point order:



For an elbow kit with integral jacket seal without a capacitive test point order:



For an elbow kit without a compression connector, use **"00"** for the conductor code.

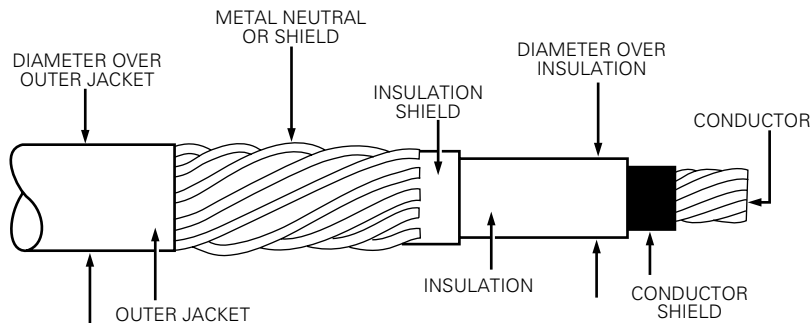

**Figure 3. Illustration showing typical construction of medium voltage underground cable.**

**STEP 5:** For an elbow where a **CSA** connector was selected in Step 2, add **"CSA"** after the test point/no test point option.

**STEP 6:** For optional braided ground strap/bleeder wire for terminating tape shielded cable, Insert **"GS"** after test point and CSA option code. **(Integral Jacket Seal Elbow Only)**

**STEP 7:** (Optional) For an elbow kit individually packaged in a corrugated cardboard box, insert an **"X"** as the last character in the part number.

**Table 3. Cable insulation diameter range**

Inches	Millimeters	Cable range code
0.610" - 0.970"	15.5 - 24.6	AB
0.750" - 1.080"	19.1 - 27.4	CC
0.890" - 1.220"	22.6 - 30.0	DD

\* Uses 5 kV cable adapter.

(For use with "CC" range elbow only.)

**Table 4. Conductor size and type**

Class B Stranded or Compressed		Compact or Solid		Conductor code
AWG	mm <sup>2</sup>	AWG	mm <sup>2</sup>	
<b>No Connector</b>				<b>00</b>
#6	16	#4	–	<b>01</b>
#4	–	#3	25	<b>02</b>
#3	25	#2	35	<b>03</b>
#2	35	#1	–	<b>04</b>
#1	–	1/0	50	<b>05</b>
1/0	50	2/0	70	<b>06</b>
2/0	70	3/0	–	<b>07</b>
3/0	–	4/0	95	<b>08</b>
4/0	95	250	120	<b>09</b>
250*	120	300	–	<b>10</b>

\* Compressed stranding only.

**Note:** Coppertop compression connector may be used on both aluminum and copper cable conductors.

**Table 5. CSA Compression connectors**

**Conductor size and type**

Stranded				
Concentric, Compressed or Compact		Solid		Conductor code
AWG	mm <sup>2</sup>	AWG	mm <sup>2</sup>	
No Connector				00
#6	16	#4	–	01
#4	–	#3	–	02
#3	–	#2	25	03
#2	25	#1	35	04
#1	35	1/0	50	05
1/0	50	2/0	70	06
2/0	70	3/0	–	07
3/0	–	–	–	08
4/0	95	–	–	09

**EXAMPLE:** Select a 28 kV integral jacket seal elbow kit with CSA connector and capacitive test point for use on a #1 compact cable with a minimum insulation diameter of 0.770" and a maximum diameter of 0.830".

**STEP 1:** From Table 3, identify the cable range 0.750–1.080" and select the **"CC"** CABLE RANGE CODE.

**STEP 2:** The conductor size is a #1 and the type is compact. **CSA** style connector required.

From Table 5, under the column "Stranded" identify #1 and select the **"05"** conductor code.

**STEP 3:** Order catalog number.

**LEJ228CC05TCSA**

**Table 6. Replacement CSA Coppertop connectors**

**Conductor size and type**

**Stranded**

**Concentric or Compressed or Compact**

**Solid**

**Catalog Number**

AWG	mm <sup>2</sup>	AWG	mm <sup>2</sup>	Catalog Number
#6	16	#4	–	CC2C01TCSA
#4	–	#3	–	CC2C02TCSA
#3	–	#2	25	CC2C03TCSA
#2	25	#1	35	CC2C04TCSA
#1	35	1/0	50	CC2C05TCSA
1/0	50	2/0	70	CC2C06TCSA
2/0	70	3/0	–	CC2C07TCSA
3/0	–	–	–	CC2C08TCSA
4/0	96	–	–	CC2C09TCSA

\* Compressed stranding only.

**Note:** Coppertop compression connector may be used on both aluminum and copper cable conductors.

**Table 7. Replacement parts**

Description	Catalog number
Hold down bail assembly	2638351C01B
Loadbreak probe installation tool	2602733A01
Probe Kit (includes Probe, Installation Tool, Silicone Lubricant, Installation Instruction Sheet)	PK225
Silicone Grease 0.175 oz tube (5 grams) 5.3 oz tube (150 grams)	2603393A03 2605670A02M
Test point cap	2639992A01
Includes Ground Braid, Constant Force Spring and Mastic	GRDBRAIDKIT

**Accessories**

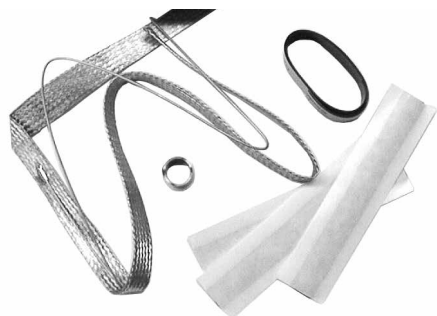

**Figure 4. Braided ground strap kit.**

This page intentionally left blank.

**Eaton**  
1000 Eaton Boulevard  
Cleveland, OH 44122  
United States  
Eaton.com

**Eaton's Power Systems Division**  
2300 Badger Drive  
Waukesha, WI 53188  
United States  
Eaton.com/cooperpowerseries

© 2019 Eaton  
All Rights Reserved  
Printed in USA  
Publication No. CA650099EN  
February 2019

Eaton is a registered trademark.  
All other trademarks are property  
of their respective owners.

For Eaton's Cooper Power series product  
information call 1-877-277-4636 or visit:  
[www.eaton.com/cooperpowerseries](http://www.eaton.com/cooperpowerseries).