

200 A 15 kV class loadbreak rotatable feedthru insert

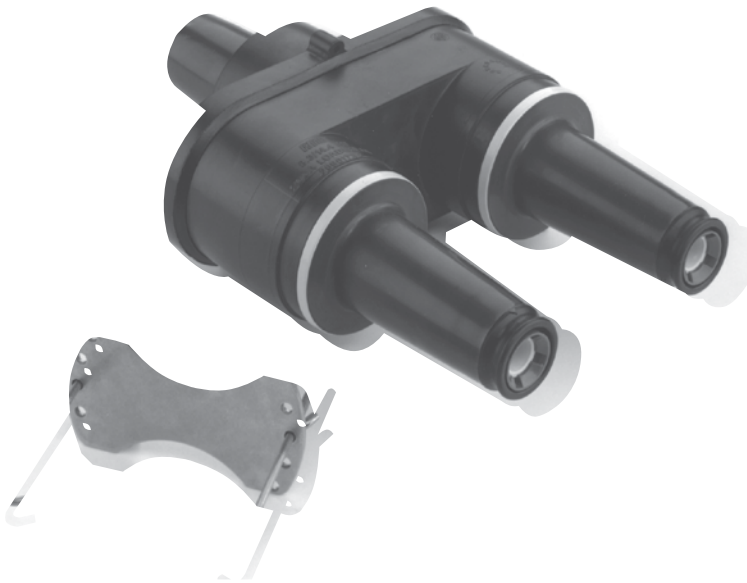

General

Eaton's Cooper Power™ series 15 kV rotatable feedthru insert is used to provide dual bushings from a single apparatus bushing well. It makes converting radial-feed transformers to feedthru transformers and adding in-line arrester protection both easy and practical. Its patented, built-in torque-limiting ratchet prevents operators from accidentally breaking bushing well studs during installation. The ratchet feature also allows the operator to rotate the feedthru insert 360° to orient it in the best position for the application. The bail assembly supplied with the kit can be used to lock the feedthru in position.

The rotatable feedthru insert incorporates an all copper current path and peroxide-cured EPDM insulation and semiconducting shield. It fully meets the requirements of IEEE Std 386™-2006 standard. When mated with comparably rated products, the insert provides a fully shielded and submersible loadbreak apparatus connection.

The latch indicator ring, located on the circumference of the bushing's collar, eliminates the guesswork of loadbreak elbow installation on the bushing interface. The bright yellow ring provides immediate feedback to determine if the elbow is properly installed on the bushing. If the yellow ring is completely covered by the loadbreak elbow, it is fully "latched;" if the ring is visible, the elbow can be installed correctly before any problems can occur.

Installation

Instruction sheet S500-13-1 details the safe installation procedures that should be followed and are included with each insert. No special tools are required for the proper installation of the insert. A cleaned and lubricated insert is simply placed in a bushing well and turned in a clockwise direction. When the torque-limiting ratchet releases, giving an audible clicking, the insert will be properly installed and tightened to the correct torque. Continued rotation in a clockwise direction allows for a full 360° positioning to meet the demands of the application. To remove a de-energized insert simply rotate in a counterclockwise direction.

EAT•N

Powering Business Worldwide

Production tests

Tests are conducted in accordance with IEEE Std 386™-2006 standard.

- AC 60 Hz 1 Minute Withstand
 - 34 kV
- Minimum Corona Voltage Level
 - 11 kV

Tests are conducted in accordance with Eaton requirements.

- Physical Inspection
- Periodic Dissection
- Periodic Fluoroscopic Analysis

Table 1. Voltage Ratings and Characteristics

Description	kV
Standard Voltage Class	15
Maximum Rating Phase-to-phase	14.4
Maximum Rating Phase-to-ground	8.3
AC 60 Hz 1 Minute Withstand	34
DC 15 Minute Withstand	53
BIL and Full Wave Crest	95
Minimum Corona Voltage Level	11

Voltage ratings and characteristics are in accordance with IEEE Std 386™-2006 standard.

Table 2. Current Ratings and Characteristics

Description	Amperes
Continuous	200 A rms
Switching	10 operations at 200 A rms at 14.4 kV
Fault Closure	10,000 A rms symmetrical at 14.4 kV for 0.17 s after 10 switching operations
Short Time	10,000 A rms symmetrical for 0.17 s
	3,500 A rms symmetrical for 3.0 s

Current ratings and characteristics are in accordance with IEEE Std 386™-2006 standard.

Ordering information

To order the 15 kV Class Rotatable Feedthru Insert Kit, refer to Table 3.

Table 3. Rotatable Feedthru Insert Kit

Description	Catalog Number
Rotatable Feedthru Insert	LF1215

Each kit contains:

- Rotatable Feedthru Insert
- Shipping Cap (not for energized operation)
- Stainless Steel Bail Assembly
- Silicone Lubricant
- Installation Instruction Sheet

Table 4. Replacement Parts

Description	Catalog Number
Bail Assembly	2604941B08

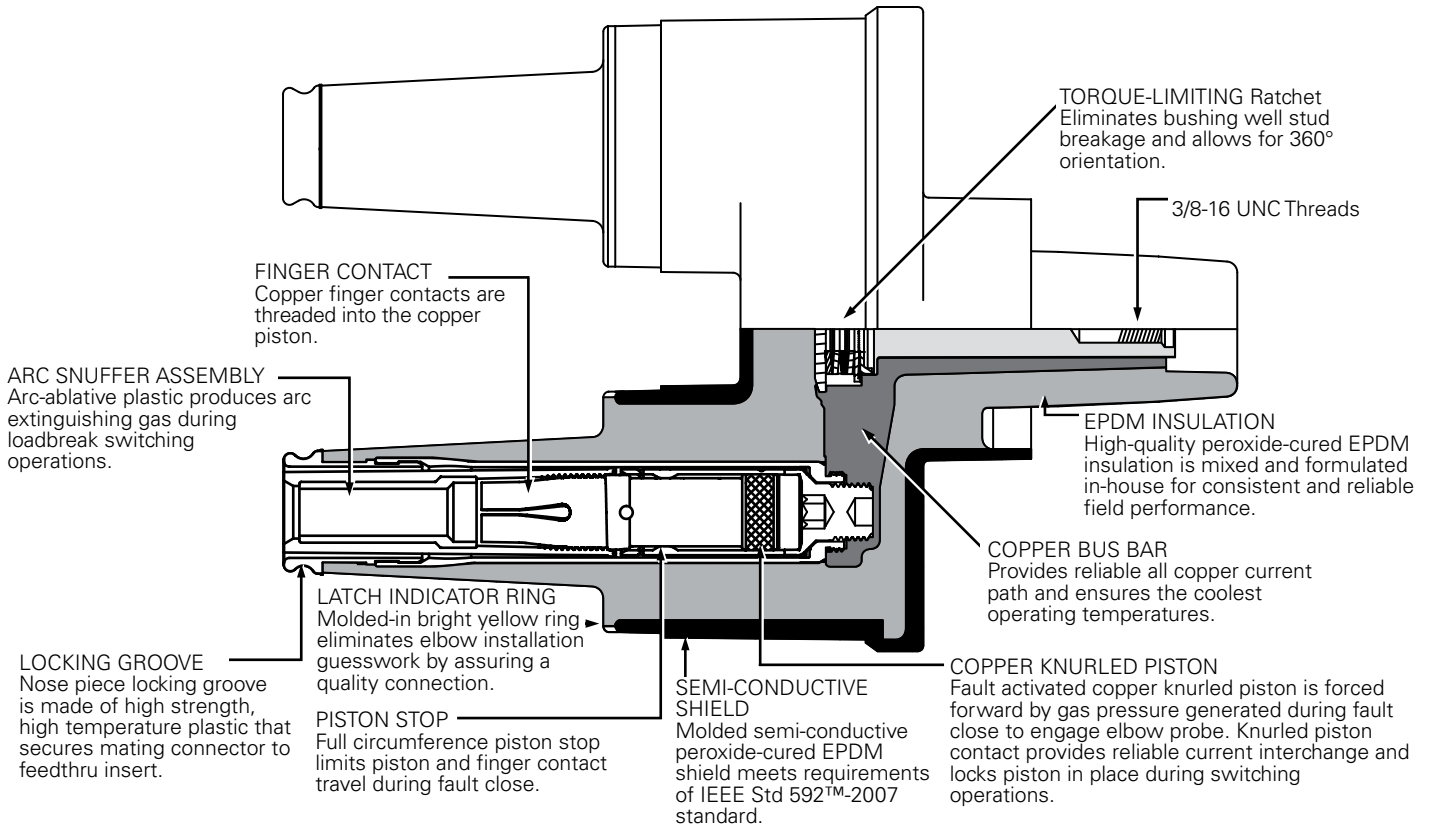
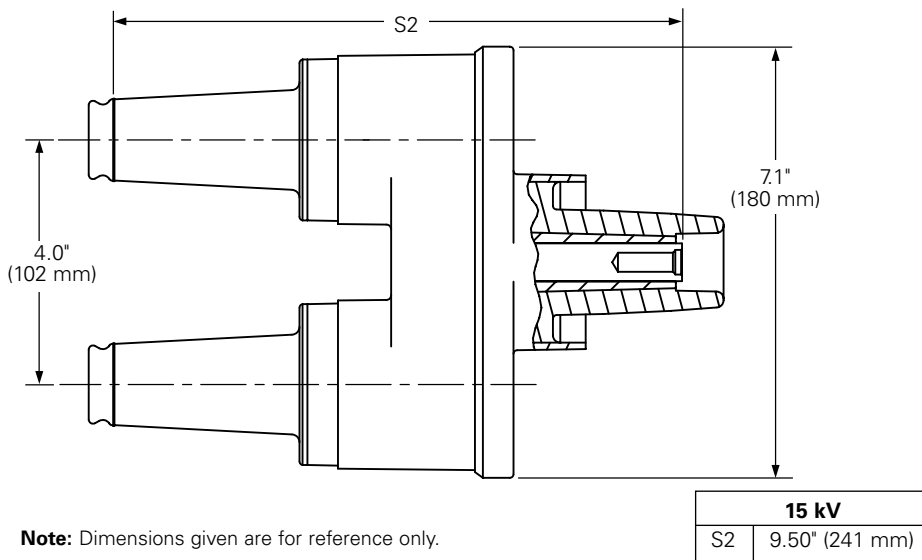

Figure 1. Illustration shows field proven, all copper alloy current path which ensures cool operating temperatures and reliability.



Note: Dimensions given are for reference only.

Figure 2. Rotatable feedthru Insert stacking dimensions.

Eaton
1000 Eaton Boulevard
Cleveland, OH 44122
United States
Eaton.com

Eaton's Cooper Power Systems Division
2300 Badger Drive
Waukesha, WI 53188
United States
Eaton.com/cooperpowerseries

© 2015 Eaton
All Rights Reserved
Printed in USA
Publication No. CA650078EN

Eaton is a registered trademark.

All other trademarks are property
of their respective owners.

For Eaton's Cooper Power series product
information call 1-877-277-4636 or visit:
www.eaton.com/cooperpowerseries.