

## 200 A 15 kV and 25 kV class insulated bushing well plug installation instructions

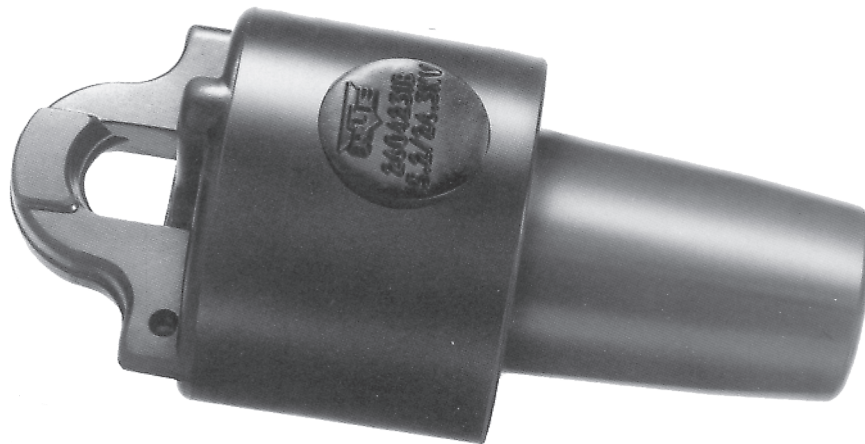

## **DISCLAIMER OF WARRANTIES AND LIMITATION OF LIABILITY**

The information, recommendations, descriptions and safety notations in this document are based on Eaton Corporation's ("Eaton") experience and judgment and may not cover all contingencies. If further information is required, an Eaton sales office should be consulted. Sale of the product shown in this literature is subject to the terms and conditions outlined in appropriate Eaton selling policies or other contractual agreement between Eaton and the purchaser.

THERE ARE NO UNDERSTANDINGS, AGREEMENTS, WARRANTIES, EXPRESSED OR IMPLIED, INCLUDING WARRANTIES OF FITNESS FOR A PARTICULAR PURPOSE OR MERCHANTABILITY, OTHER THAN THOSE SPECIFICALLY SET OUT IN ANY EXISTING CONTRACT BETWEEN THE PARTIES. ANY SUCH CONTRACT STATES THE ENTIRE OBLIGATION OF EATON. THE CONTENTS OF THIS DOCUMENT SHALL NOT BECOME PART OF OR MODIFY ANY CONTRACT BETWEEN THE PARTIES.

In no event will Eaton be responsible to the purchaser or user in contract, in tort (including negligence), strict liability or otherwise for any special, indirect, incidental or consequential damage or loss whatsoever, including but not limited to damage or loss of use of equipment, plant or power system, cost of capital, loss of power, additional expenses in the use of existing power facilities, or claims against the purchaser or user by its customers resulting from the use of the information, recommendations and descriptions contained herein. The information contained in this manual is subject to change without notice.

**Contents**

**DISCLAIMER OF WARRANTIES AND LIMITATION OF LIABILITY . . . . . I**

**CONTENTS. . . . . II**

**SAFETY FOR LIFE . . . . . III**

**SAFETY INFORMATION . . . . . III**

    Safety instructions. . . . . iii

**PRODUCT INFORMATION. . . . . 1**

    Introduction . . . . . 1

    Acceptance and initial inspection . . . . . 1

    Handling and storage. . . . . 1

    Quality standards. . . . . 1

    Equipment required. . . . . 2

    Tools required . . . . . 2

**INSTALLATION PROCEDURE . . . . . 2**

    Clean and lubricate . . . . . 2



## Safety for life



Eaton's Cooper Power series products meet or exceed all applicable industry standards relating to product safety. We actively promote safe practices in the use and maintenance of our products through our service literature, instructional training programs, and the continuous efforts of all Eaton employees involved in product design, manufacture, marketing, and service.

We strongly urge that you always follow all locally approved safety procedures and safety instructions when working around high-voltage lines and equipment, and support our "Safety For Life" mission.

### Safety information

The instructions in this manual are not intended as a substitute for proper training or adequate experience in the safe operation of the equipment described. Only competent technicians who are familiar with this equipment should install, operate, and service it.

A competent technician has these qualifications:

- Is thoroughly familiar with these instructions.
- Is trained in industry-accepted high and low-voltage safe operating practices and procedures.
- Is trained and authorized to energize, de-energize, clear, and ground power distribution equipment.
- Is trained in the care and use of protective equipment such as flash clothing, safety glasses, face shield, hard hat, rubber gloves, clampstick, hotstick, etc.

Following is important safety information. For safe installation and operation of this equipment, be sure to read and understand all cautions and warnings.

### Hazard Statement Definitions

This manual may contain four types of hazard statements:

#### DANGER

Indicates a hazardous situation which, if not avoided, will result in death or serious injury.

#### WARNING

Indicates a hazardous situation which, if not avoided, could result in death or serious injury.

#### CAUTION

Indicates a hazardous situation which, if not avoided, could result in minor or moderate injury.

#### CAUTION

Indicates a hazardous situation which, if not avoided, could result in equipment damage only.

### Safety instructions

Following are general caution and warning statements that apply to this equipment. Additional statements, related to specific tasks and procedures, are located throughout the manual.

#### DANGER

**Hazardous voltage. Contact with hazardous voltage will cause death or severe personal injury. Follow all locally approved safety procedures when working around high- and low-voltage lines and equipment.**

G103.3

#### WARNING

**Before installing, operating, maintaining, or testing this equipment, carefully read and understand the contents of this manual. Improper operation, handling or maintenance can result in death, severe personal injury, and equipment damage.**

G101.0

#### WARNING

**This equipment is not intended to protect human life. Follow all locally approved procedures and safety practices when installing or operating this equipment. Failure to comply can result in death, severe personal injury and equipment damage.**

G102.1

#### WARNING

**Power distribution and transmission equipment must be properly selected for the intended application. It must be installed and serviced by competent personnel who have been trained and understand proper safety procedures. These instructions are written for such personnel and are not a substitute for adequate training and experience in safety procedures. Failure to properly select, install or maintain power distribution and transmission equipment can result in death, severe personal injury, and equipment damage.**

G122.3

## Product information

### Introduction

Eaton's Cooper Power series 200 A, 15 and 25 kV Class Insulated Bushing Well Plug meets the full requirements of IEEE Std 386™ standard - Separable, Insulated Connector Systems. The insulated bushing well plug provides an insulated, fully shielded, submersible cover for an unused 15 kV Class or 25 kV Class bushing well in deadfront equipment. The body is molded of high quality EPDM insulation and has a molded semi-conductive EPDM shield. A molded ground tab on the shield allows attachment of ground wire to ensure deadfront construction.

---

### WARNING

---

**Hazardous Voltage. All associated apparatus must be de-energized during any hands-on installation or maintenance. Failure to comply could result in death and severe personal injury.**

---

### CAUTION

---

**Eaton's Cooper Power series 200 A Insulated Bushing Well Plug is designed to be operated in accordance with normal safe operating procedures. These instructions are not intended to supersede or replace existing safety and operating procedures.**

**The insulated bushing well plug should be installed and serviced only by personnel familiar with good safety practices and the handling of high-voltage electrical equipment.**

---

### Read this manual first

---

**Read and understand the contents of this manual and follow all locally approved procedures and safety practices before installing or operating this equipment.**

### Additional information

These instructions cannot cover all details or variations in the equipment, procedures, or process described nor provide directions for meeting every possible contingency during installation, operation, or maintenance. For additional information, contact your representative.

### Acceptance and initial inspection

Each insulated bushing well plug is in good condition when accepted by the carrier for shipment. Upon receipt, inspect the shipping container for signs of damage. Unpack the insulated bushing well plug and inspect it thoroughly for damage incurred during shipment. If damage is discovered, file a claim with the carrier immediately.

### Handling and storage

Be careful during handling and storage of the insulated bushing well plug to minimize the possibility of damage. If the insulated bushing well plug is to be stored for any length of time prior to installation, provide a clean, dry storage area.

### Quality standards

ISO 9001 Certified Quality Management System

# 200 A 15 kV and 25 kV class insulated bushing well plug installation instructions

## Equipment required

- Insulated Bushing Well Plug Kit including:
  - Bushing Well Plug
  - Lubricant
  - Instruction Sheet

## Tools required

- Hotstick

## Installation procedure

### Step 1.

#### Clean and lubricate

- Mating surface of the bushing well and insulated bushing well plug must be clean and free of any foreign contaminants.
- A thin coating of the supplied lubricant or equivalent must be evenly applied to the entire mating surfaces of the insulated bushing well plug and as much of the bushing well inside circumference that can be reached. See Figure 1.

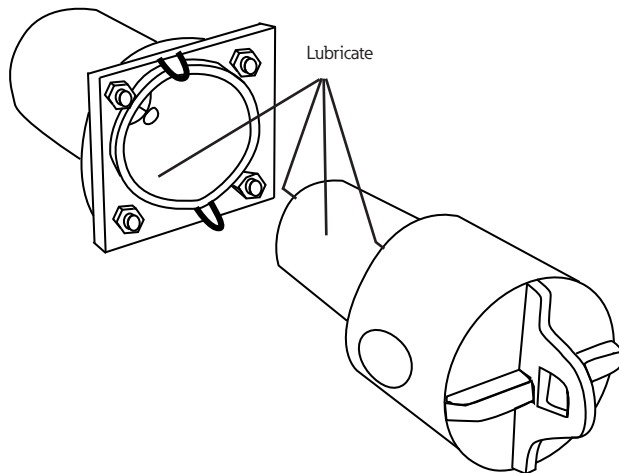

Figure 1. Lubricate plug and bushing mating interfaces.

### Step 2.

#### Install

**Note:** The insulated bushing well plug may be installed with or without a hotstick.

- Set mating portion of insulated bushing well plug into bushing well.
- Turn plug clockwise until metal insert bottoms on the bushing well stud.

### Step 3.

#### Ground

- Attach copper drain wire (Minimum # 14 AWG) to insulated bushing well plug grounding tab.
- Connect drain wire to system ground.

This page intentionally left blank.



**Eaton**  
1000 Eaton Boulevard  
Cleveland, OH 44122  
United States  
Eaton.com

**Eaton's Power Systems Division**  
2300 Badger Drive  
Waukesha, WI 53188  
United States  
Eaton.com/cooperpowerseries

© 2016 Eaton  
All Rights Reserved  
Printed in USA  
Publication No. MN650038EN/Rev 0  
(Supersedes S500201 Rev 0)  
November 2016

Eaton is a registered trademark.

All trademarks are property  
of their respective owners.

For Eaton's Cooper Power series product  
information  
call 1-877-277-4636 or visit:  
[www.eaton.com/cooperpowerseries](http://www.eaton.com/cooperpowerseries).