

200 A 15 and 25 kV class elbow with integral jacket seal\* for use on tape and wire shielded cable installation instructions



\*US Patent 7,661,979

**EATON**

*Powering Business Worldwide*

## **DISCLAIMER OF WARRANTIES AND LIMITATION OF LIABILITY**

The information, recommendations, descriptions and safety notations in this document are based on Eaton Corporation's ("Eaton") experience and judgment and may not cover all contingencies. If further information is required, an Eaton sales office should be consulted. Sale of the product shown in this literature is subject to the terms and conditions outlined in appropriate Eaton selling policies or other contractual agreement between Eaton and the purchaser.

THERE ARE NO UNDERSTANDINGS, AGREEMENTS, WARRANTIES, EXPRESSED OR IMPLIED, INCLUDING WARRANTIES OF FITNESS FOR A PARTICULAR PURPOSE OR MERCHANTABILITY, OTHER THAN THOSE SPECIFICALLY SET OUT IN ANY EXISTING CONTRACT BETWEEN THE PARTIES. ANY SUCH CONTRACT STATES THE ENTIRE OBLIGATION OF EATON. THE CONTENTS OF THIS DOCUMENT SHALL NOT BECOME PART OF OR MODIFY ANY CONTRACT BETWEEN THE PARTIES.

In no event will Eaton be responsible to the purchaser or user in contract, in tort (including negligence), strict liability or otherwise for any special, indirect, incidental or consequential damage or loss whatsoever, including but not limited to damage or loss of use of equipment, plant or power system, cost of capital, loss of power, additional expenses in the use of existing power facilities, or claims against the purchaser or user by its customers resulting from the use of the information, recommendations and descriptions contained herein. The information contained in this manual is subject to change without notice.

# Contents

## SAFETY INFORMATION

Safety Information . . . . .	iv
------------------------------	----

## PRODUCT INFORMATION

Introduction . . . . .	1
Acceptance and Initial Inspection . . . . .	1
Handling and Storage . . . . .	1
Quality Standards . . . . .	1

## INSTALLATION INSTRUCTIONS

Installation Instructions . . . . .	2
Preparation of Tape and Wire Shielded Cable . . . . .	2
Elbow Installation . . . . .	6
Loadbreak Probe Installation . . . . .	7

## OPERATING PROCEDURES

Loadmake Operation . . . . .	9
Fault Close . . . . .	9
Loadbreak Operation . . . . .	9



## Safety for life



Eaton meets or exceeds all applicable industry standards relating to product safety in its Cooper Power™ series products. We actively promote safe practices in the use and maintenance of our products through our service literature, instructional training programs, and the continuous efforts of all Eaton employees involved in product design, manufacture, marketing, and service.

We strongly urge that you always follow all locally approved safety procedures and safety instructions when working around high voltage lines and equipment, and support our “Safety For Life” mission.

## Safety information

The instructions in this manual are not intended as a substitute for proper training or adequate experience in the safe operation of the equipment described. Only competent technicians who are familiar with this equipment should install, operate, and service it.

A competent technician has these qualifications:

- Is thoroughly familiar with these instructions.
- Is trained in industry-accepted high and low-voltage safe operating practices and procedures.
- Is trained and authorized to energize, de-energize, clear, and ground power distribution equipment.
- Is trained in the care and use of protective equipment such as arc flash clothing, safety glasses, face shield, hard hat, rubber gloves, clampstick, hotstick, etc.

Following is important safety information. For safe installation and operation of this equipment, be sure to read and understand all cautions and warnings.

### Hazard Statement Definitions

This manual may contain four types of hazard statements:

#### DANGER

Indicates an imminently hazardous situation which, if not avoided, will result in death or serious injury.

#### WARNING

Indicates a potentially hazardous situation which, if not avoided, could result in death or serious injury.

#### CAUTION

Indicates a potentially hazardous situation which, if not avoided, may result in minor or moderate injury.

**CAUTION:** Indicates a potentially hazardous situation which, if not avoided, may result in equipment damage only.

### Safety instructions

Following are general caution and warning statements that apply to this equipment. Additional statements, related to specific tasks and procedures, are located throughout the manual.

#### DANGER

**Hazardous voltage. Contact with hazardous voltage will cause death or severe personal injury. Follow all locally approved safety procedures when working around high- and low-voltage lines and equipment.**

G103.3

#### WARNING

**Before installing, operating, maintaining, or testing this equipment, carefully read and understand the contents of this manual. Improper operation, handling or maintenance can result in death, severe personal injury, and equipment damage.**

G101.0

#### WARNING

**This equipment is not intended to protect human life. Follow all locally approved procedures and safety practices when installing or operating this equipment. Failure to comply can result in death, severe personal injury and equipment damage.**

G102.1

#### WARNING

**Power distribution and transmission equipment must be properly selected for the intended application. It must be installed and serviced by competent personnel who have been trained and understand proper safety procedures. These instructions are written for such personnel and are not a substitute for adequate training and experience in safety procedures. Failure to properly select, install or maintain power distribution and transmission equipment can result in death, severe personal injury, and equipment damage.**

G122.3

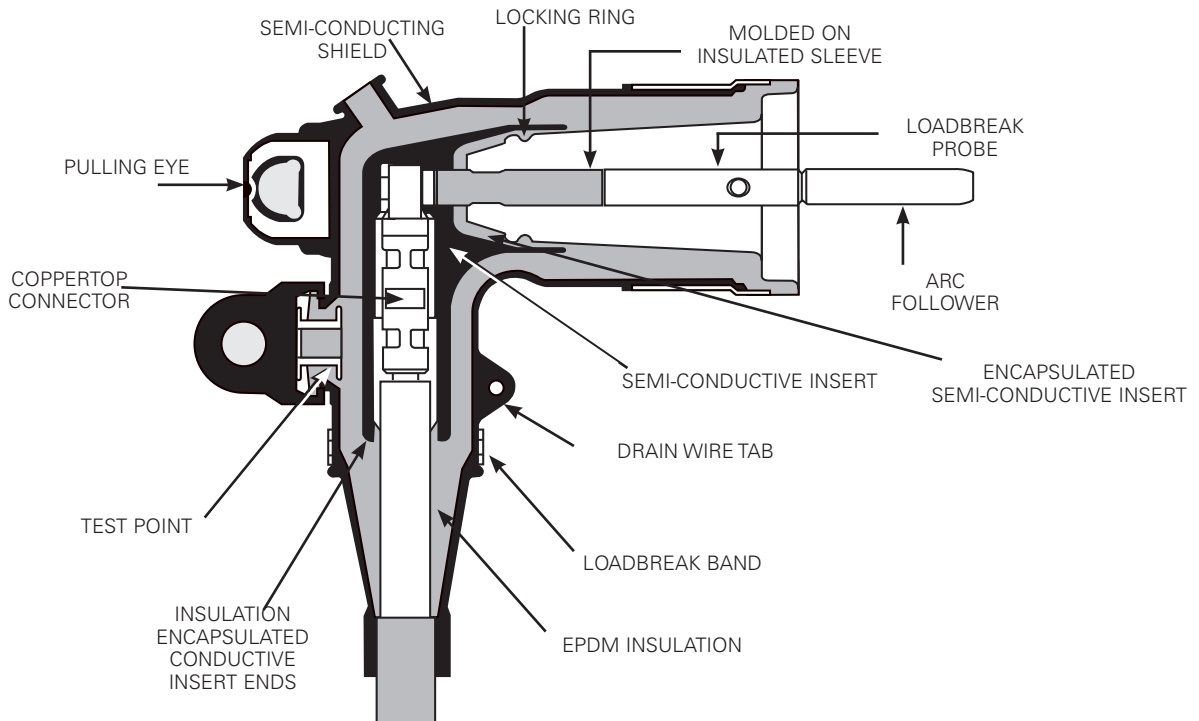

Line illustration of 200 A 25 kV expanded range POSI-BREAK™ elbow.

---

**⚠ WARNING**

**All associated apparatus must be de-energized during any hands-on installation or maintenance. Failure to comply could result in death, severe personal injury and equipment damage.**

---

**Product information**

**Introduction**

Eaton's Cooper Power™ series loadbreak elbow connector is a fully-shielded and insulated plug-in termination for connecting underground cable to transformers, switching cabinets and junctions equipped with loadbreak bushings. The elbow connector and bushing insert comprise the essential components of all loadbreak connections.

**Read this manual first**

Read and understand the contents of this manual and follow all locally approved procedures and safety practices before installing or operating this equipment

**Additional information**

These instructions cannot cover all details or variations in the equipment, procedures, or process described nor provide directions for meeting every possible contingency during installation, operation, or maintenance. When additional information is desired to satisfy a problem not covered sufficiently for the user's purpose, please contact your Eaton representative.

---

**⚠ WARNING**

**Optional Capacitive Test Point Operating Instructions: Use only voltage indicating instruments specifically designed for test points. Use of conventional voltage sensing devices may provide false "No Voltage" indications.**

**The test point must be dry and free of contaminants when checking for voltage. After indication is taken: clean, dry, and lubricate the test point cap with silicone grease and assemble to the test point.**

**Always consider the termination to be energized until the test point "No Voltage" indication is confirmed by other means. Failure to comply could result in death or severe personal injury.**

---

**Acceptance and initial inspection**

Each loadbreak elbow connector is completely inspected and tested at the factory. It is in good condition when accepted by the carrier for shipment. Upon receipt of a loadbreak elbow connector kit, inspect the connector thoroughly for damage and loss of parts incurred during shipment. If damage or loss is discovered, file a claim with the carrier immediately.

**Handling and storage**

If the loadbreak elbow connector is to be stored for an appreciable time before installation, provide a clean, dry storage area. Locate the connector so as to minimize the possibility of physical damage.

## Quality standards

ISO 9001 Certified Quality Management System

## Installation procedures

Cable stripping and scoring tools, available from various tool manufacturers, are recommended for use when installing loadbreak elbows. After preparing the cable, the elbow housing is pushed onto the cable. The load-break probe is threaded into the coppertop connector using the supplied installation tool or an approved equivalent. Use a clampstick to perform loadmake and loadbreak operations. **(See page 9 for operating instructions.)**

Complete elbow kit includes:

- Standard Elbow Body or Elbow Body with Jacket Seal
- Coppertop Compression Connector
- Loadbreak Probe
- Probe Installation Tool
- Silicone Lubricant
- Mastic Strips (**Jacket Seal Elbow Only**)
- Installation Instruction Sheet

Tools/Accessories needed:

- Tape Measure
- Wire Brush
- Knife
- Cable Stripping Tool
- Crimping Tool
- Cable Cleaner
- Cable Cutters
- Clampstick
- Personal Protection Equipment

## Preparation of tape and wire shielded cable

### Cable Training

Position cable vertically so that it is centered between apparatus bushing and parking pocket, parallel to the apparatus frontplate. Provide adequate slack in the cable to permit unrestricted movement of the elbow connector from the apparatus bushing to a standoff bushing or portable feedthru.

Once installed, the cable should enter the elbow connector in a straight line. Avoid a tight bend radius at the cable entrance of the elbow that causes the elbow to bend. (See Figure 1.)

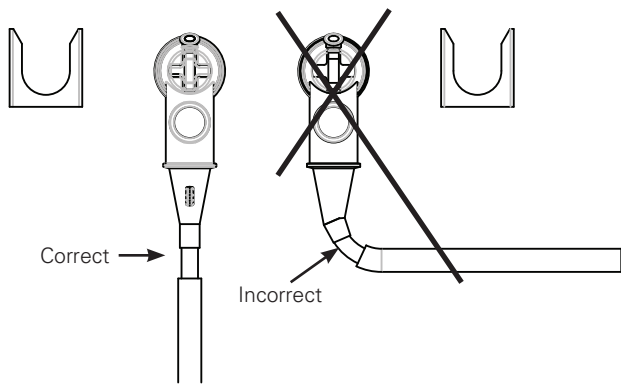

**Figure 1. Proper Cable Training.**

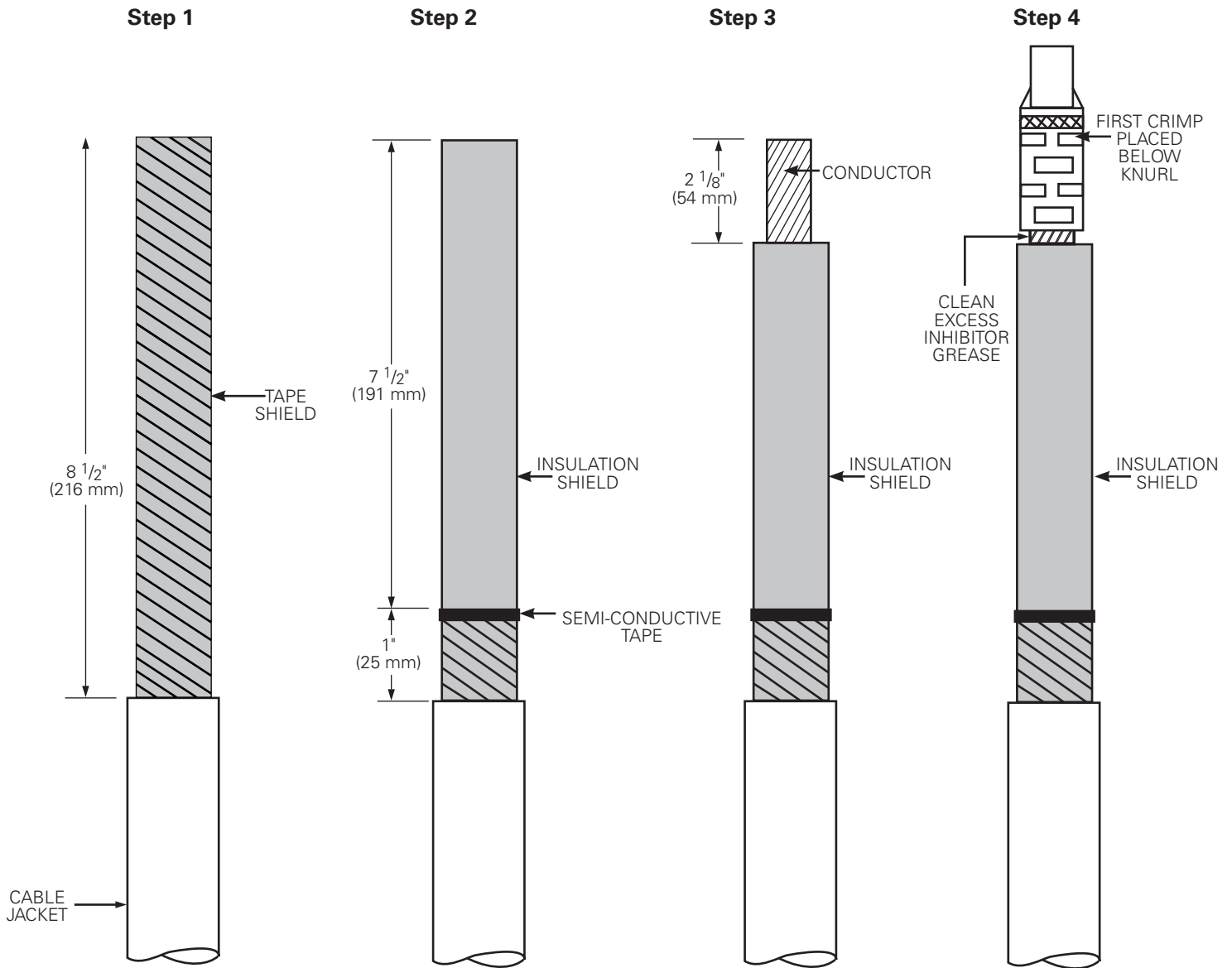

### Step 1.

Measure down from top of the cable 8-1/2" (216 mm).

Remove cable jacket (if jacketed cable is used) to expose metallic shielding tape or wires. (Tape shielded cable shown.)

### Step 2.

Remove 7-1/2" (191 mm) of metallic shielding leaving a minimum of 1" (25 mm) exposed at cable jacket end. Bind end of metallic shield with two highly stretched wraps of semi-conductive tape.

### Step 3.

Measure down from the top of the cable 2-1/8" (54 mm).

Remove the insulation and conductor shield to expose the bare conductor. Take care not to nick the conductor.

### Step 4.

Clean the exposed conductor using a wire brush.

**Note: The probe (male contact) should be preassembled into the threads of the compression connector prior to crimping to ensure proper thread engagement.**

Place the coppertop (bimetal) connector on the conductor. Make sure the threaded hole in connector faces the apparatus bushing.

Crimp the connector in place using a tool and die combination and minimum suggested number of crimps ( ) as shown in Table 1 of page 8. Start crimping just below the knurled line and rotate each successive crimp to prevent bowing. Do not overlap crimps.

Clean excessive inhibitor grease from coppertop connector by wiping toward threaded eye.

Smooth any sharp edges on the crimp connector surface.

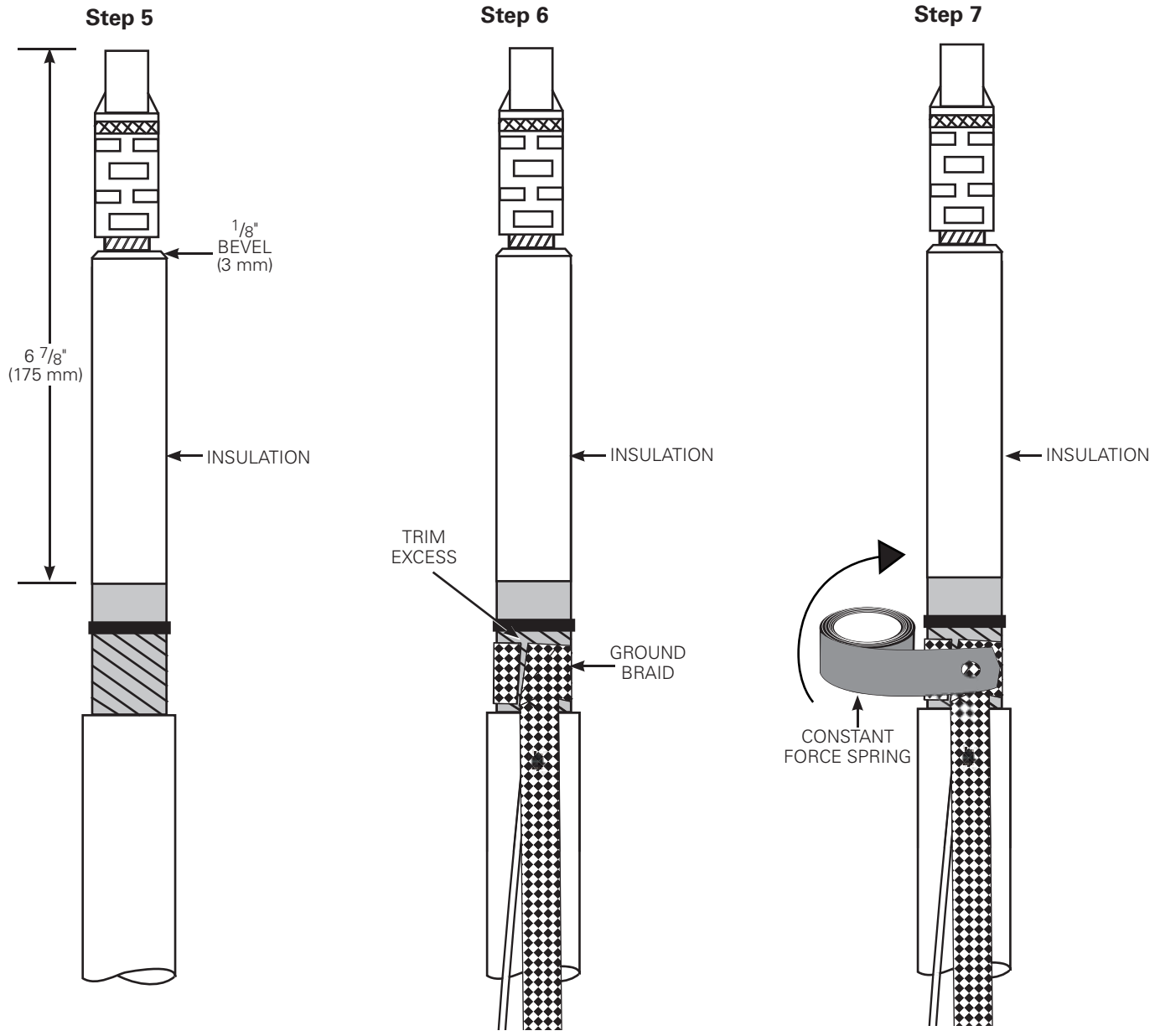

**Step 5.**

Measure down from the top of the connector 6-7/8" (175 mm).

Remove the insulation shield. Take care not to nick or gouge the insulation.

Place a 1/8" bevel on the insulation to ease elbow installation.

**Step 6.**

Position performed ground braid with long end along cable jacket.

Wrap braid around the cable metallic/wire shield and cut off excess (do not overlap braid onto itself).

**Step 7.**

Secure in place with constant force spring supplied. Cinch (tighten) last lap of spring.



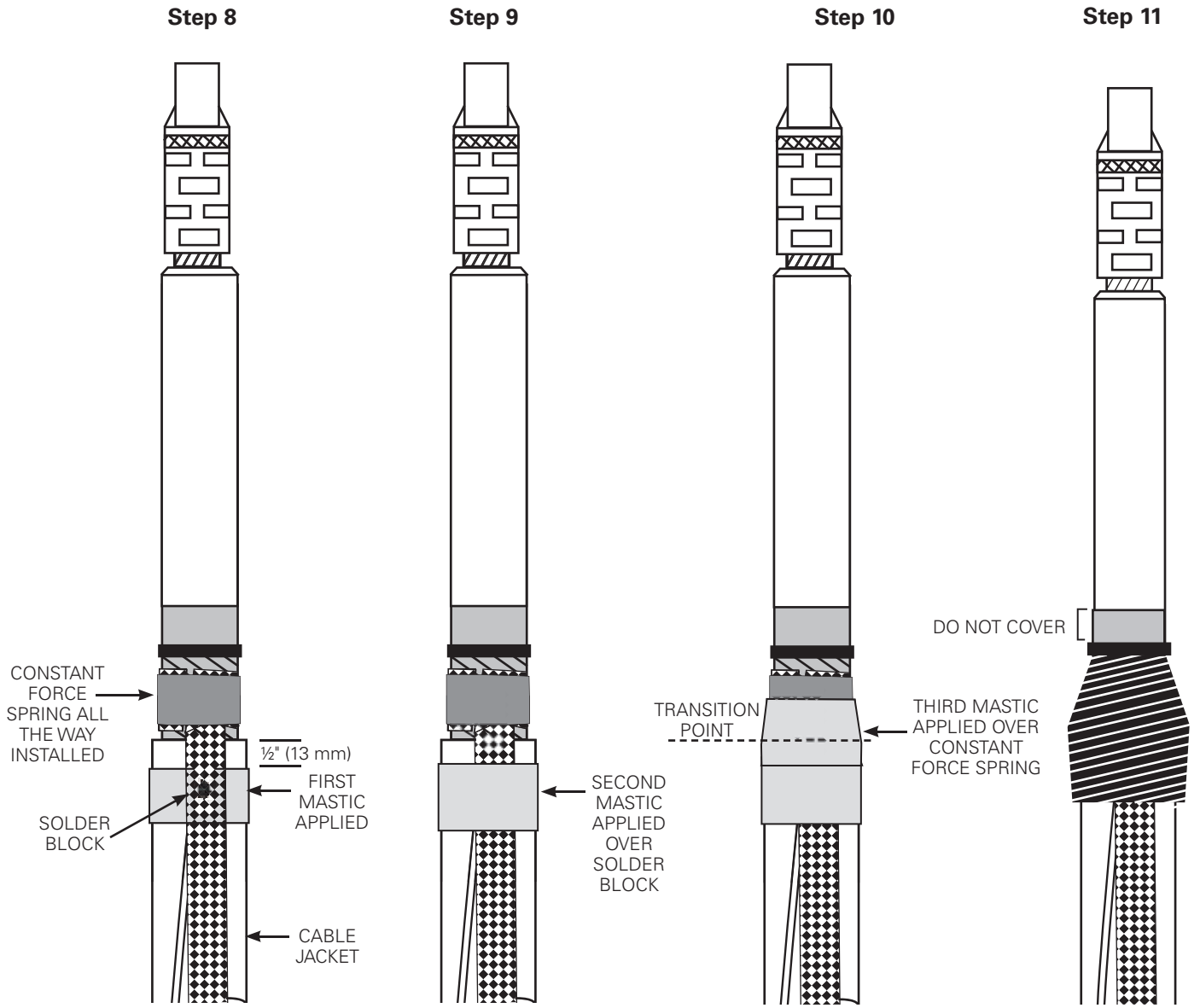

**Step 8.**

Select one of three mastic strips. Remove liner and wrap one layer of mastic around the cable jacket 1/2" (13 mm) from the cut edge of the jacket, underneath the solder-block area of the braid. (Do not stretch the mastic while applying.)

**Step 9**

Apply second mastic strip layer directly over the solder-block and first layer of mastic. Press in place.

**Step 10**

Add the third strip of mastic at the transition point of the cable jacket and braided ground strap/constant force spring. Press in place.

**STEP 11.**

Start at the end of the metallic shield and apply two half-lapped layers of vinyl tape (not supplied) over the constant force spring and mastic seal. Extend the tape application onto the cable jacket 1/4" (6 mm) beyond the mastic seal.

**Note:** Do not cover the exposed insulation shield.

### Step 12

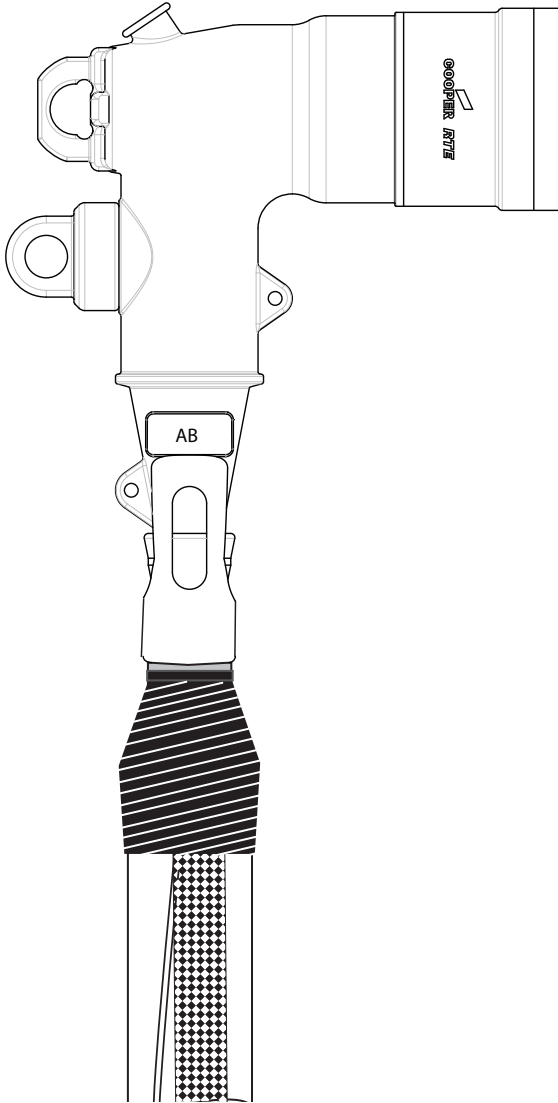

### Step 13

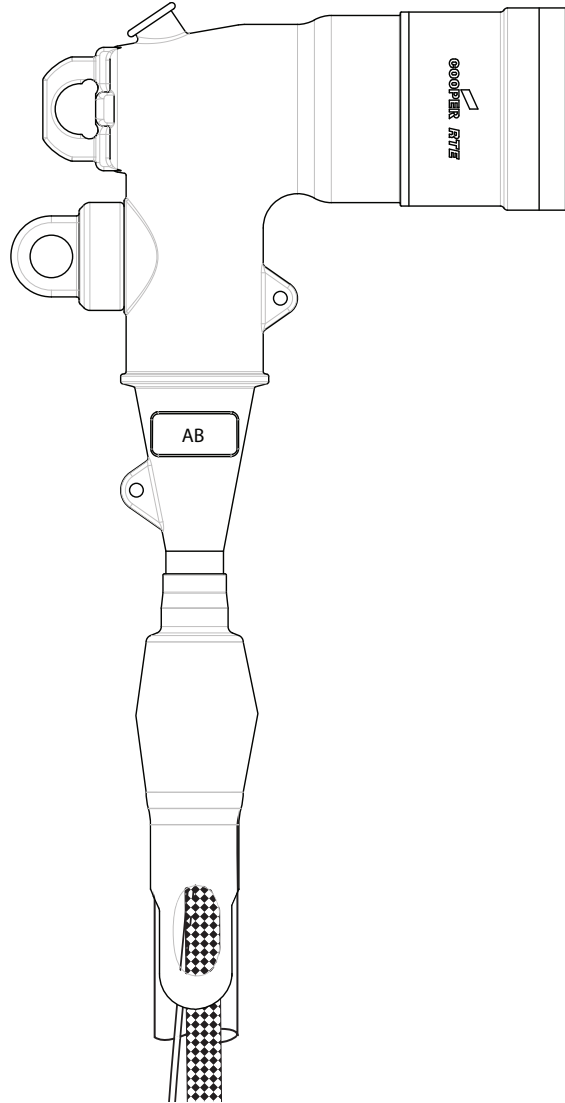

#### Step 12

Clean the insulation with a lint free cloth saturated with a cleaning solution. Wipe the insulation toward the insulation shield.

Apply a thin coating of supplied lubricant to the insulation.

Clean and lubricate the cable entrance of the elbow.

Place elbow on cable. With a twisting motion, push the elbow onto the cable until the threaded eye of the cooper top connector is aligned with the elbow.

#### Step 13

Apply a thin layer of supplied silicone grease over the cable and vinyl tape. Grasping the thumbholes of the jacket seal, pull down firmly over the cable until all of the vinyl tape is covered.

### Step 14

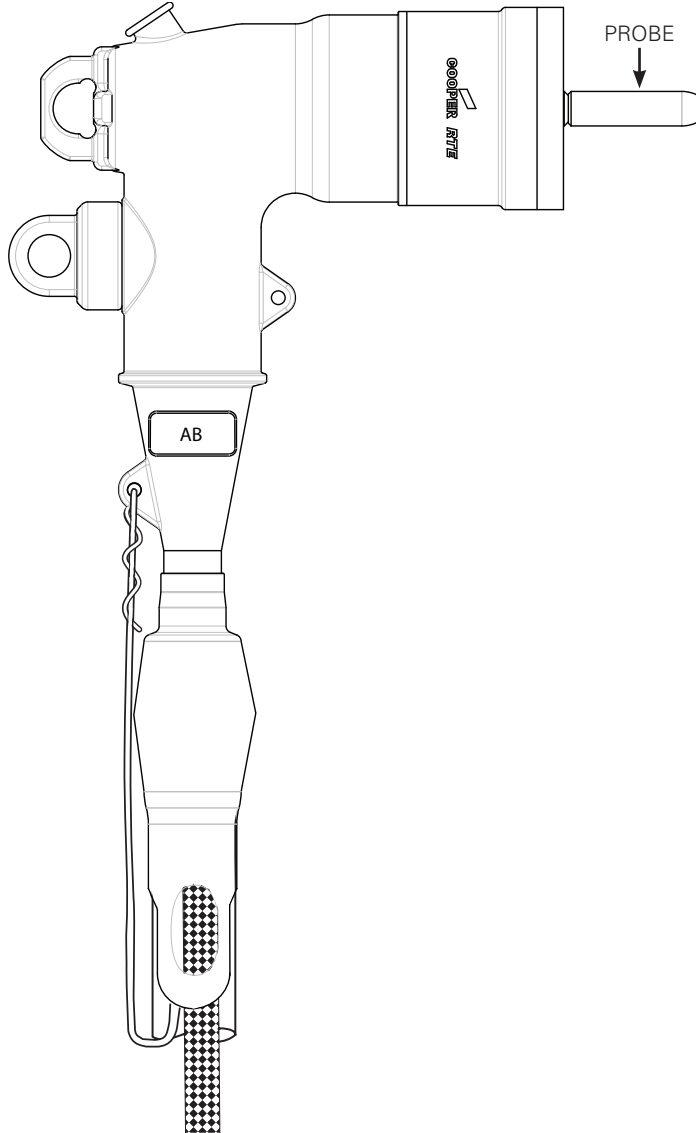

### Step 14

Push down and twist the elbow to align the coppertop compression connector, the threaded hole in the connector should be centered with respect to the hole in the elbow and perpendicular to the probe axis. By hand, insert the probe into the elbow along the center axis of the interface and thread the loadbreak probe into the coppertop connector. A thin layer of silicone lubricant applied to the last 1/4" of the probe body (not on the threads) can aid in installation, especially when installing a POSI-BREAK™ elbow probe.

**Note: If installing a POSI-BREAK elbow, be sure to use a POSI-BREAK probe with black insulating sleeve.**

After at least three full turns or when the probe is seated (five (5) 1/2 turns) onto the connector, use the provided installation tool to properly torque the loadbreak probe. Proper torque is applied when the tool twists at least 180° (1/2 turn).

**Note: If a different installation tool is used it must apply a torque of 100 to 120 lbf-in (11.0 - 13.5 N-m).**

Clean and lubricate bushing and elbow interface areas with a thin even coating of the silicone lubricant provided.

Attach a drain wire lead from the ground braid to the drain wire eye of the elbow.

**Table 1. Crimp Chart**

<b>CONNECTOR</b>		<b>5/8" DIAMETER</b>					<b>3/4" DIAMETER</b>			
<b>CONDUCTOR SIZE</b>		<b>NO. 4 THRU 2/0 STRANDED</b>					<b>3/0 - 4/0 STRANDED</b>			
<b>Burndy®</b>	TOOL	Y34	Y35 OR Y39		MD6		Y34	Y35 OR Y39		MD6
	DIE	A243 (2)	U243 (2)	UBG (2)	W243 (3)	WBG (2)	U247 (2)	U247 (2)	U467 (2)	W247 (5)
		A25AR (2)	U25ART (2)	U687 (2)	BG (4) NOSE	W687 (2)	A27AR (2)	U27ART (1)		
<b>Thomas and Betts</b>	TOOL	UT-3	UT-5		UT-15		UT-5		UT-15	
	DIE	5/8" (4)	TV (4)		54 H (2)		TV (4)		66 (2)	
<b>Kearney™</b>	TOOL	0			WH2, WH3, BH4, WH4, PH2, PH13		0		WH2, WH3, BH4, WH4, PH2, PH13	
	DIE	5/8" NOSE (4)	9/16" (3)	9/16" (2)	572 (2)		737 (3)	747 (2)	737 (3)	747 (2)
<b>ACA Conductor Accessories</b>	TOOL	12 A					12 A			
	DIE	B24 EA (2)					B39 EA (2)			
<b>Anderson® Tool</b>		VC-5, VC-6					VC-5, VC-6			
<b>Edison Electric Institute - REFERENCE</b>		8 A					10 A			

( ) Minimum suggested number of crimps.

## Operating procedures

---

 **WARNING**

---

**The operator should always use personal protective equipment (insulated gloves, clampstick and eye protection) whenever operating the elbow. The operator should always be in the best possible operating position, providing firm footing and enabling a secure grasp of the clampstick, while maintaining positive control of the elbow before, during and immediately after operation. If there is any question regarding the operator's operating position, de-energize the elbow before operation. The operator should not be looking directly at the connector during the moment of circuit interruption or connection. Failure to comply could result in death or serious injury.**

---

Do not connect two different phases of a multiple-phase system. Before closing a single-phase loop, make certain both ends of the loop are the same phase.

### Loadmake operation

- Area must be clear of obstructions or contaminations that would interfere with the operation of the loadbreak elbow.
- Securely fasten a clampstick to the pulling eye of the elbow.
- Place the loadbreak elbow over the bushing, inserting the white arc follower of the probe into the bushing approximately 2-1/2" (64 mm) until a slight resistance is felt. This will align and stabilize the elbow.
- Turn your back to the bushing and grasp the clampstick securely and obtain good footing. Slam the elbow onto the bushing with one quick and continuous motion.
- Turn around and apply a force to the clampstick to push the elbow onto the bushing. A popping or snapping sound is often heard when this operation is performed.
- To check that the elbow is properly latched apply a gentle pull force to the clampstick. When latched properly the elbow will not slide back off of the bushing.
- As a last operation, push on the clampstick to seat the elbow all the way onto the bushing again. This insures that the elbow is latched and was not dislodged during the latching check in previous step above.

### Fault close

1. It is not recommended that operations be made on known faults.
2. If a fault is experienced, the elbow connector, probe, and the bushing must be replaced.

### Loadbreak operation

- Area must be clear of obstructions or contaminants that would interfere with this operation.
- Use clampstick to secure standoff insulator or portable feedthru in bracket. Ground devices to system ground per appropriate Installation Instructions. All associated apparatus must also be grounded.
- Secure elbow eye firmly onto clampstick and lock.
- Twist clampstick clockwise until the elbow rotates slightly on bushing — about 1/4" (6 mm). This action will break any surface friction between outer surface of bushing and inner surface of elbow.
- Withdraw elbow from bushing with a fast, firm, straight motion. Minimum amount of travel of elbow to break load is 9" (229 mm).
- Use clampstick to place elbow on lubricated standoff insulator or portable feedthru. (Follow loadmake instructions.)
- Place an insulated protective cap with ground wire attached to system ground on any exposed energized bushing using clampstick. Follow the same operating procedures as for the elbow as outlined above under Loadmake Operation.

This page intentionally left blank.

This page intentionally left blank.

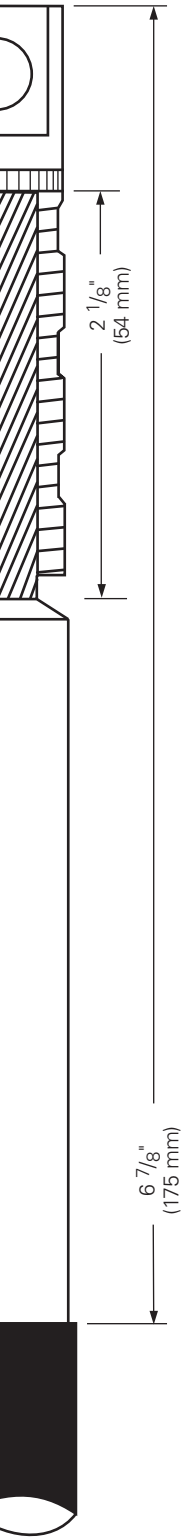

**Eaton**  
 1000 Eaton Boulevard  
 Cleveland, OH 44122  
 United States  
 Eaton.com

**Eaton's Cooper Power Systems  
 Division**  
 2300 Badger Drive  
 Waukesha, WI 53188  
 United States  
 Eaton.com/cooperpowerseries

© 2015 Eaton  
 All Rights Reserved  
 Printed in USA  
 Publication No. MN650009EN Rev 00  
 (Supersedes S500108 Rev 04)

Eaton, Cooper Power, POSI-BREAK, and Kearney are valuable trademarks of Eaton in the U.S. and other countries. You are not permitted to use these trademarks without the prior written consent of Eaton.  
 Burndy® is a registered trademark of FCI.  
 Thomas and Betts® is a registered trademark of Thomas and Betts.  
 ACA Conductor Accessories is a division of AFL Telecommunications LLC.  
 Anderson® is a registered trademark of Hubbell Power Systems.

For Eaton's Cooper Power series loadbreak elbow product information call 1-877-277-4636 or visit: [www.eaton.com/cooperpowerseries](http://www.eaton.com/cooperpowerseries).