

200 A 15 and 25 kV class deadbreak elbow connector



Description

Eaton's Cooper Power™ series deadbreak elbow connector is a fully-shielded and insulated plug-in termination for connecting underground cable to transformers, switching cabinets and junctions equipped with deadbreak bushings. The elbow connector and bushing comprise the essential components of deadbreak separable connections.

Deadbreak elbows are molded using high quality peroxide-cured EPDM insulation. Standard features include a copperTop connector, tin plated copper probe, stainless steel reinforced pulling-eye, and a capacitive test point.

Cable ranges are sized to accept a wider range of cable diameter for a given size elbow. The wider cable ranges increase installation flexibility.

The coppertop compression connector is a standard item to transition from the cable to the probe. An aluminum crimp barrel is inertia-welded to a copper lug. The aluminum barrel makes the connector easy to crimp and the copper lug ensures a reliable, tight, cool operating connection with the deadbreak probe.

Installation

Cable stripping and scoring tools, available from various tool manufacturers, are recommended for use when installing deadbreak elbows. After preparing the cable, the elbow housing is pushed onto the cable. The probe is threaded into the coppertop connector using the supplied installation tool. A bail assembly is also included to assure a safe, reliable connection.

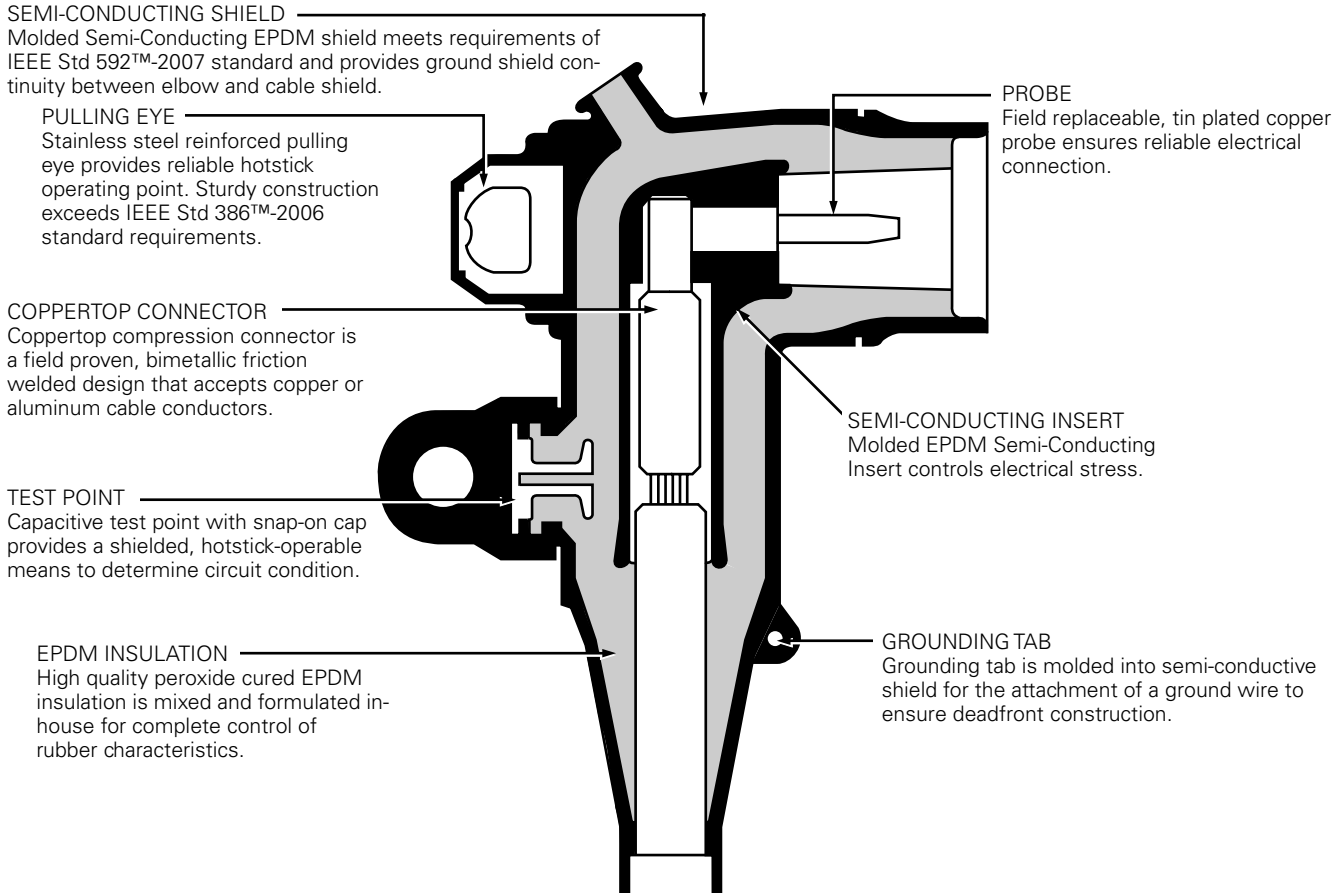

Figure 1. Elbow cutaway illustrates design integrity.

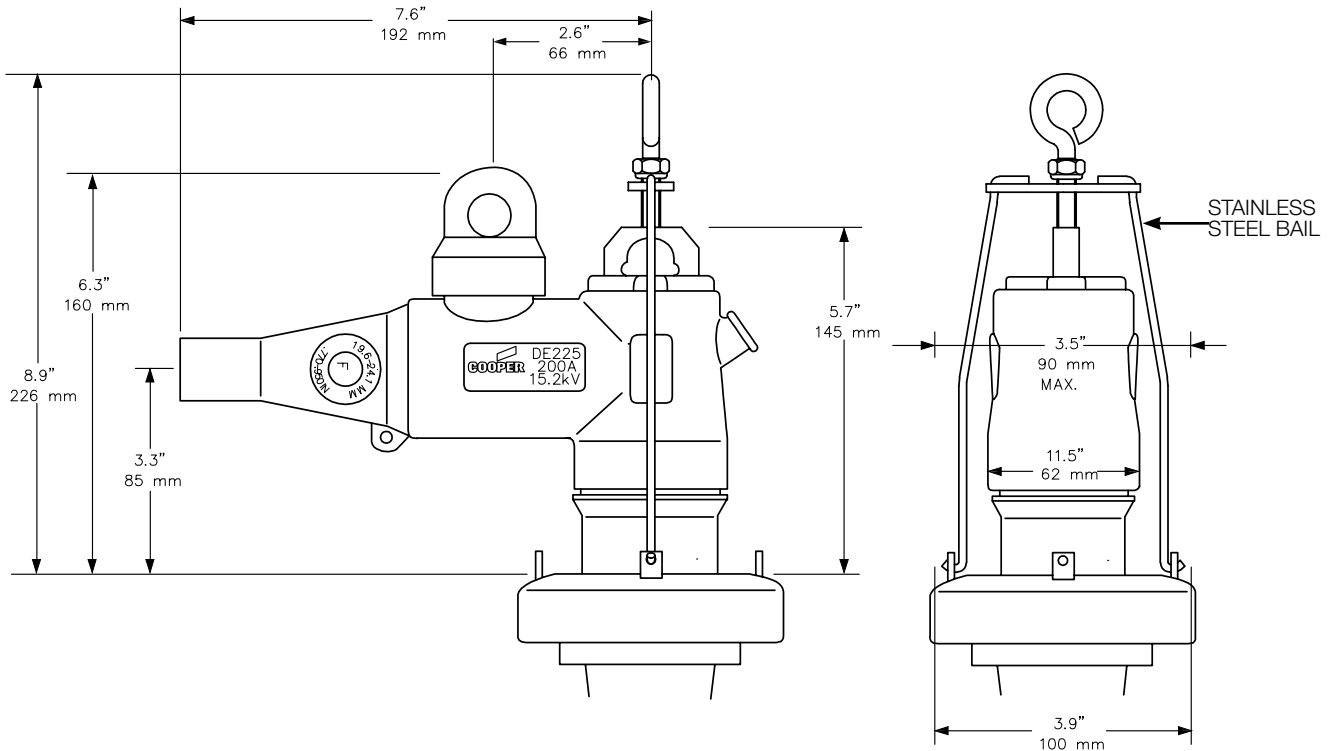

Figure 2. DE225 deadbreak elbow connector dimensional information.

Production tests

Tests conducted in accordance with IEEE Std 386™-2006 standard:

- ac 60 Hz 1 Minute Withstand
 - 40 kV
- Minimum Partial Discharge Extinction Voltage
 - 19 kV
- Test Point Voltage Test

Tests are conducted in accordance with Eaton requirements:

- Physical Inspection
- Periodic Dissection
- Periodic Fluoroscopic Analysis

Table 1. Voltage Ratings and Characteristics

Description	kV
Standard Voltage Class	25
Maximum Rating Phase-to-Ground	15.2
ac 60 Hz 1 Minute Withstand	40
dc 15 Minute Withstand	78
BIL and Full Wave Crest	125
Minimum Partial Discharge Extinction Voltage	19

Voltage ratings and characteristics are in accordance with IEEE Std 386™-2006 standard.

Table 2. Current Ratings and Characteristics

Description	Amperes
Continuous	200 A rms
Short Time	10,000 A rms symmetrical for 0.17 s
	3,500 A rms symmetrical for 3.0 s

Current ratings and characteristics are in accordance with IEEE Std 386™-2006 standard.

Ordering information

The standard elbow kit is packaged in a heavy-duty polyethylene bag and bulk-packed, 20 kits to a multipak box. Individual boxed kits are also available by special part number. To order a 15/25 kV Class Deadbreak Elbow Kit, for cable meeting AEIC CS5 and CS6, follow the easy steps below.

Each kit contains:

- Elbow Body
- CopperTop Compression Connector
- Copper Probe
- Probe Installation Tool
- Bail Assembly
- Silicone Lubricant
- Installation Instruction Sheet

STEP 1: Determine the cable's diameter over the electrical insulation as shown in Figure 3 (including tolerances). Then identify a cable range from Table 3 that brackets the minimum and maximum insulation diameters. Select the CABLE RANGE CODE from the far right column.

STEP 2: Identify the conductor size and type in Table 4 and select the CONDUCTOR CODE from the far right column.

STEP 3: For an elbow kit with a capacitive test point order:



For an elbow kit without a compression connector, use "00" for the conductor code.

For an elbow kit individually packaged in a corrugated cardboard box, insert an "X" as the last character in the part number.

EXAMPLE: Select an elbow kit with a capacitive test point for use on a #1 compact cable with a nominal insulation diameter of .760".

STEP 1: Nominal diameter over the insulation is 0.760" ± .030".

Minimum Diameter
0.760" - .030" = 0.730"

Maximum Diameter
0.760" + .030" = 0.790"

From Table 3, identify the cable range .642"-.819" and select the "D" CABLE RANGE CODE.

STEP 2: The conductor size is a #1 and the type is compact.

From Table 4, under the column "Compact or Solid" identify #1 and select the "04" conductor code.

STEP 3: Order catalog number.

DE 225 DA 04 T

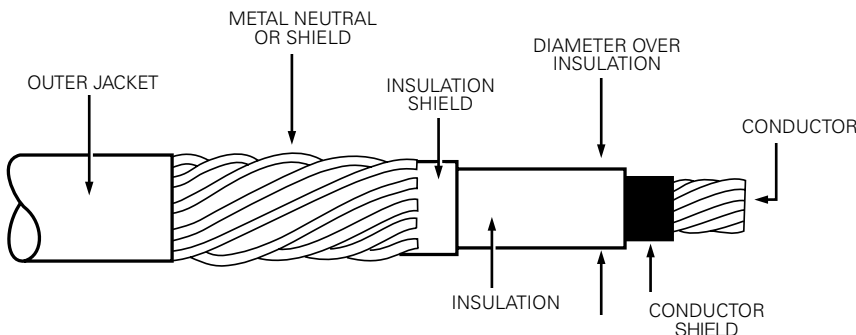

Figure 3. Illustration showing typical construction of medium voltage underground cable.

Table 3. Cable Range

Cable Range		Cable Range Code
Inches	Millimeters	
.531-.685	18.5-17.4	BA
.642-.819	16.3-20.8	DA
.772-.949	19.6-24.1	FA
.909-1.13	23.1-28.7	HA
1.10-1.32	27.9-33.5	JA

Table 4. Conductor Size and Type

Concentric or Compressed		Compact or Solid		Conductor Code
AWG	mm ²	AWG	mm ²	
No Connector				00
#6	16	#4	-	01
#4	-	#3	-	02
#3	-	#2	25	03
#2	25	#1	35	04
#1	35	1/0	50	05
1/0	50	2/0	70	06
2/0	70	3/0	-	07
3/0	-	4/0	95	08
4/0	95	250	120	09
250*	120	300	-	10

* Compressed stranding only.

Table 5. Replacement Coppertop Connectors**Conductor Size**

Concentric or Compressed		Compact or Solid		Catalog Number
AWG	mm²	AWG	mm²	
#6	16	#4	–	CC2C01T
#4	–	#3	25	CC2C02T
#3	25	#2	35	CC2C03T
#2	35	#1	–	CC2C04T
#1	–	1/0	50	CC2C05T
1/0	50	2/0	70	CC2C06T
2/0	70	3/0	–	CC2C07T
3/0	–	4/0	95	CC2C08T
4/0	96	250	120	CC2C09T
250*	120	300	–	CC2C10T

* Compressed Stranding Only

Note: CopperTop compression connector may be used on both aluminum and copper cable conductors.

Table 6. Replacement Parts

Description	Catalog Number
Deadbreak Probe Installation Tool	2639205B01
Deadbreak Probe Only	2638370C01EX
Bail Assembly	2638409C06B
Silicone Grease	
.25 oz tube	2603393A03
5.2 oz tube	2605670A02M
Test Point Cap	2638855C02

Eaton
1000 Eaton Boulevard
Cleveland, OH 44122
United States
Eaton.com

Eaton's Cooper Power Systems Division
2300 Badger Drive
Waukesha, WI 53188
United States
Eaton.com/cooperpowerseries

© 2015 Eaton
All Rights Reserved
Printed in USA
Publication No. CA650048EN

Eaton and Cooper Power is a valuable trademark of Eaton in the U.S. and other countries. You are not permitted to use these trademarks without the prior written consent of Eaton.

IEEE Std 386™-2006 and IEEE Std 592™-2007 standards are trademarks of the Institute of Electrical and Electronics Engineers, Inc., (IEEE). This publication/product is not endorsed or approved by the IEEE.

For Eaton's Cooper Power series deadbreak elbow connector product information call 1-877-277-4636 or visit: www.eaton.com/cooperpowerseries.