

150 A single-phase series multiple (dual voltage) switches



General

Eaton designs its Cooper Power™ series single-phase series multiple (dual voltage) switch to change connection of de-energized transformer windings between series and parallel to provide different common transformer voltage ratios. They also make it possible to stock one transformer with voltage conversion capability. Using stacked multi-layer switches and auxiliary back switches, voltages such as 2400 V x 7620 V or 7200 V x 19920 V can be provided. Tri-voltage switches are also available.

Externally operable switches eliminate many of the hazards associated with manual internal tap changing of distribution transformers because line crews need not be exposed to high-voltage conductors and hot transformer fluids. They also eliminate the need to dismount pole-type transformers for voltage adjustment and prevent exposure of the transformer tank interiors to contamination. The switches are designed for use in distribution transformers filled with transformer oil, Envirotemp™ FR3™ fluid or an approved equivalent.

Series multiple (dual voltage) switches are available with cap/wrench, lever, "T", or hotstick-operable handles. The lever handle has an indexing screw to ensure complete, positive switch contact. The cap/wrench handle has an innovative "one-way-in/one-way-out" operating feature that ensures positive operation. The threaded cap protects the shaft seal. The spring-loaded pad lockable handle is hotstick-operable. It allows greater leverage and provides positive indication of switch position.

The switch shaft is made of a high strength glass-reinforced nylon, and is sealed against leakage by two high temperature resistant Viton® O-rings. The switch body and rotor are made of glass-reinforced polyester. The spring tempered, high conductivity copper pinch-type rotor contacts, provide dependable self-cleaning action.

Series multiple (dual voltage) switches are available with either bolt tab or crimp terminals. Switches with crimp terminals have additional inboard tapped holes for making separate ring tongue connections without changing switch contacts. All terminals have hex recesses to hold 7/16 inch hex bolt heads of standard 1/4 inch hardware for fast, easy connections.

EATON

Powering Business Worldwide

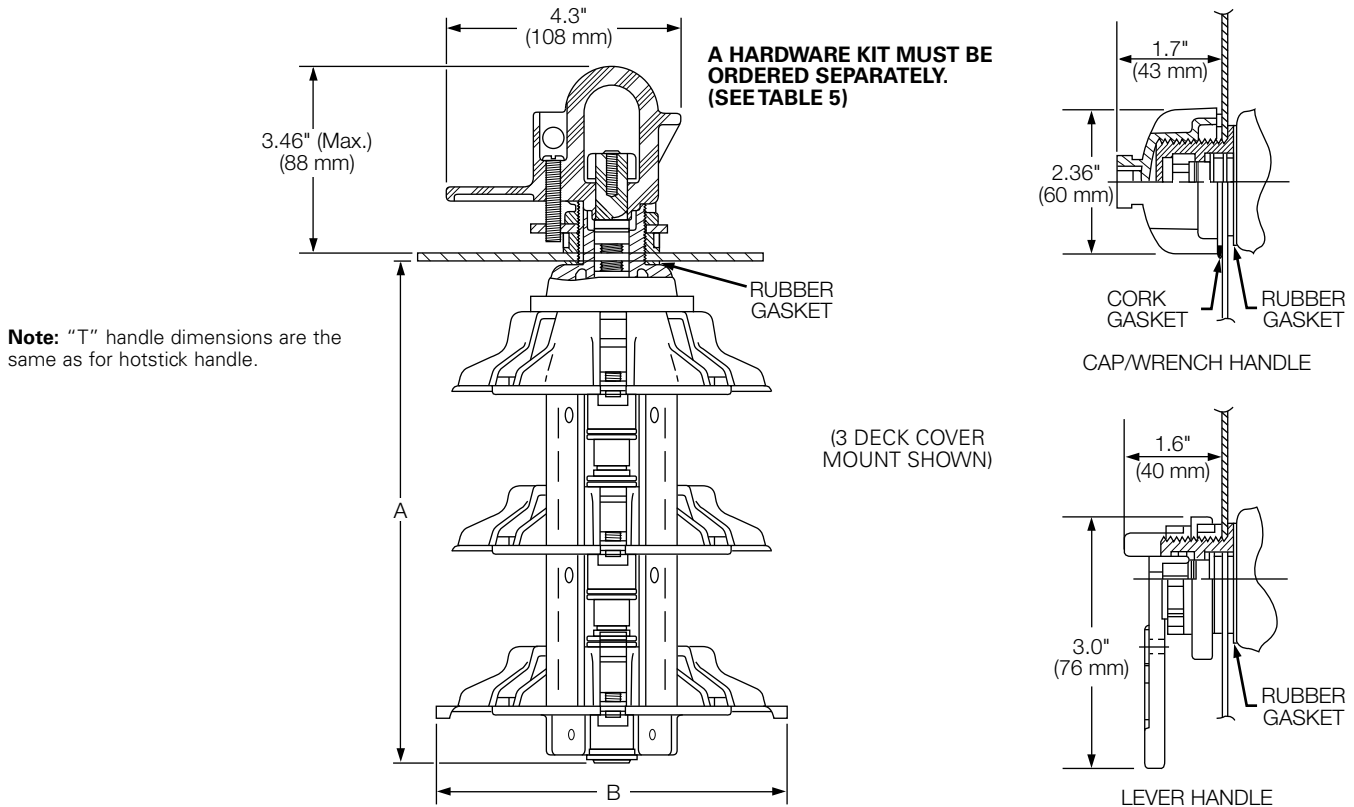

Figure 1. Series Multiple Switch. (Padlockable Hotstick Handle Options Shown On Switch.)

Note: Dimensions given are for reference only.

Table 1. Voltage Ratings and Characteristics

Description	kV
Standard Voltage Class	35 Max.
AC 60 Hz 1 Minute Withstand	50
BIL and Full Wave Crest (in both series and parallel positions)	150

Voltage ratings and characteristics are in accordance with IEEE Std C57.12™ standard.

Table 2. Current Ratings and Characteristics

Description	Amperes
Continuous	150 A rms series position
	300 A rms parallel position

Table 3. Multiple Switch Configurations

Switch Type	Dimensions-in./(mm)				
	A	B (w/Terminals)			
		Bolt Tab	Bolt Tab w/Stud	#14-16 #10-12 #8	#6
1-Phase Standard (1 Deck)	3.31	5.52	5.52	6.63	6.88
	(84 mm)	(140 mm)	(140 mm)	(168 mm)	(175 mm)
1-Phase With Back Decks (2 Decks)	5.713	5.52	5.52	6.63	6.88
	(145 mm)	(140 mm)	(140 mm)	(168 mm)	(175 mm)
1-Phase Cover Mount (3 Decks)*	9.20	5.52	5.52	6.63	6.88
	(232 mm)	(140 mm)	(140 mm)	(168 mm)	(175 mm)

* The upper two decks have no contacts – for spacing only.

Installation

No special tools are required. The switch body is installed through a keyed 1.33 inch (34 mm) hole in the tank wall and sealed by an inside gasket. An outer sealing nut is tightened to a torque of 80 to 120 in-lbs. Refer to Installation Instruction Sheet S800-72-1 for details.

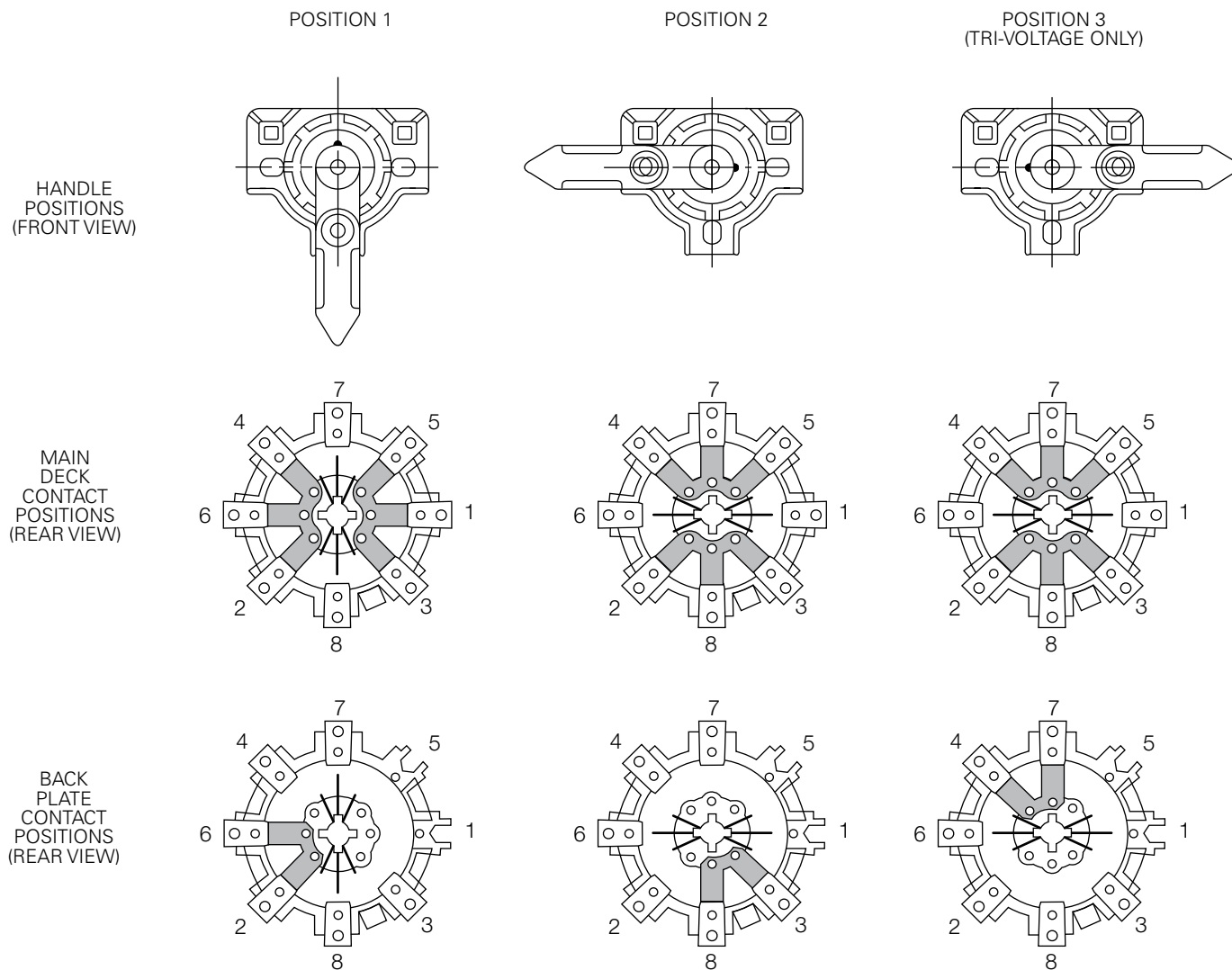

Figure 2. Switch Contact Positions. (Typical switch shown. For specifics refer to Table 5.)

Ordering information

To order a 150 A externally operated series multiple switch, specify one switch and one hardware kit from the charts on pages 4-5.

Table 4. Abbreviations and Definitions

DV	Dual Voltage, 6 or 8 Terminals, 2-3 Finger Contacts.
TV	Tri-Voltage, 6 or 8 Terminals, 2-3 Finger Contacts.
BP	Backplate (Backswitch), 4 Terminals, 2 Finger Contacts.
DBP	Double Backplate, 8 Terminals, 2-2 Finger Contacts.
2BP	Two Backplates, 4 Terminals each, 2 Finger Contacts each.
1BP	One Backplate, at end of switch, 4 Terminals, 2 Finger Contacts.
TD	Terminal Deck, 2 Terminals (B.T.), w/o Rotor Assembly or Finger Contacts
CM/DV	Cover Mounted Switch.
SP	Special Switch with non-standard quantities and placements of terminals and contacts.

Table 5. Cap Wrench or Lever Handle Operated Series Multiple Switches^e

Catalog Number	Switch Type ^f	Description	Contacts		No. of Terminals on Front Phase Deck	"N" Drawing No.	
			Phase	Back Deck ^f			
Switch Number	Hardware Kit ^{a,b} TV	DV DM/DV	One	BP, DBP 1BP, SP	#14-16 #10-12 #8, #6		
2237434C01M 2237434C02M 2237434C03M 2237434C04M 2237434C05M 2237434C16M	Cap Wrench 2237947A02H or Lever Handle 2237947A08H ^d	DV DV DV DV DV DV	1Ø 1Ø 1Ø 1Ø 1Ø 1Ø	— — — — — —	Bolt Tab #14 - 16 #10 - 12 #8 #6 Bolt Tab w/Stud ^c	6 6 6 6 6 6	720
2237434C51M 2237434C52M 2237434C53M 2237434C54M 2237434C55M 2237434C66M	Cap Wrench 2237947A02H or Lever Handle 2237947A08H ^d	DV DV DV DV DV DV	1Ø 1Ø 1Ø 1Ø 1Ø 1Ø	— — — — — —	Bolt Tab #14 - 16 #10 - 12 #8 #6 Bolt Tab w/Stud ^c	8 8 8 8 8 8	720
2237435C01M 2237435C02M 2237435C03M 2237435C04M 2237435C05M 2237435C06M	Cap Wrench 2237947A02H or Lever Handle 2237947A08H ^d	DV DV DV DV DV DV	1Ø 1Ø 1Ø 1Ø 1Ø 1Ø	BP BP BP BP BP BP	Bolt Tab #14 - 16 #10 - 12 #8 #6 Bolt Tab w/Stud ^c	6 6 6 6 6 6	721
2237435C51M 2237435C52M 2237435C53M 2237435C54M 2237435C55M 2237435C66M	Cap Wrench 2237947A02H or Lever Handle 2237947A08H ^d	DV DV DV DV DV DV	1Ø 1Ø 1Ø 1Ø 1Ø 1Ø	BP BP BP BP BP BP	Bolt Tab #14 - 16 #10 - 12 #8 #6 Bolt Tab w/Stud ^c	6 6 8 8 8 8	721
2237492C01M 2237492C02M 2237492C03M 2237492C04M 2237492C05M	Cap Wrench 2237947A02H or Lever Handle 2237947A08H ^d	DV DV DV DV DV	1Ø 1Ø 1Ø 1Ø 1Ø	DBP DBP DBP DBP DBP	Bolt Tab #14 - 16 #10 - 12 #8 #6	6 6 6 6 6	867
2237984C01M 2237984C02M 2237984C03M 2237984C04M 2237984C05M	Cap Wrench 2237947A02H or Lever Handle 2237947A08H ^d	DV DV DV DV DV	1Ø 1Ø 1Ø 1Ø 1Ø	SP SP SP SP SP	#14 - 16 #10 - 12 #8 #6 Bolt Tab	8 8 8 8 8	915
2238066C06M 2238066C07M 2238066C08M 2238066C09M 2238066C10M	Cap Wrench 2237947A02H or Lever Handle 2237947A08H ^d	DV DV DV DV DV	1Ø 1Ø 1Ø 1Ø 1Ø	SP SP SP SP SP	Bolt Tab #14 - 16 #10 - 12 #8 #6	8 8 8 8 8	913
2237576C01M 2237576C02M 2237576C03M 2237576C04M 2237576C05M 2237576C06M	Cap Wrench 2237947A02H or Lever Handle 2237947A08H ^d	CM/DV CM/DV CM/DV CM/DV CM/DV CM/DV	1Ø 1Ø 1Ø 1Ø 1Ø 1Ø	SP SP SP SP SP SP	Bolt Tab #14 - 16 #10 - 12 #8 #6 Bolt Tab w/Stud ^c	6 6 6 6 6 6	798
2237576C51M 2237576C52M 2237576C53M 2237576C54M 2237576C55M 2237576C56M	Cap Wrench 2237947A02H or Lever Handle 2237947A08H ^d	CM/DV CM/DV CM/DV CM/DV CM/DV CM/DV	1Ø 1Ø 1Ø 1Ø 1Ø 1Ø	SP SP SP SP SP SP	Bolt Tab #14 - 16 #10 - 12 #8 #6 Bolt Tab w/Stud ^c	8 8 8 8 8 8	798
2237438C01M 2237438C02M 2237438C03M 2237438C04M 2237438C05M	Lever Handle 2237947A09H ^d	TV TV TV TV TV	1Ø 1Ø 1Ø 1Ø 1Ø	BP BP BP BP BP	Bolt Tab #14 - 16 #10 - 12 #8 #6	6 6 6 6 6	724
2237438C51M 2237438C52M 2237438C53M 2237438C54M 2237438C55M	Lever Handle 2237947A09H ^d	TV TV TV TV TV	1Ø 1Ø 1Ø 1Ø 1Ø	BP BP BP BP BP	Bolt Tab #14 - 16 #10 - 12 #8 #6	8 8 8 8 8	724
2238011C01M 2238011C02M 2238011C03M 2238011C04M 2238011C05M	Lever Handle 2237947A09H	TV TV TV TV TV	1Ø 1Ø 1Ø 1Ø 1Ø	SP SP SP SP SP	Bolt Tab #14 - 16 #10 - 12 #8 #6	8 8 8 8 8	925

a Hardware Kits are not included with the switch, Hardware Kits must be ordered separately.
 b Actuating devices are included in the Hardware Kits.
 c Bolt Tab w/Stud (1/4-20 threaded stud).

d Add "P" to end of the part number to make lever handle padlockable.
 e For configuration not found, consult with your factory representative.
 f For abbreviations and definitions see Table 4.

Table 6. Padlockable Hotstick Handle or "T" Handle Operated Series Multiple Switches^d

Catalog Number		Switch Type ^e	Description	Contacts		No. of Terminals on Front Phase Deck	"N" Drawing No.
Switch Number	Hardware Kit ^{a,b}	DV CDM/DV TV	Phase	Back Deck ^e	Bolt Tab Bolt Tab w/Stud ^c		
			One	BP, DBP 2BP, 1BP SP, TD	#14-16 #10-12 #8, #6		
2237262C01M	Hotstick Handle 2237947A07H or "T" Handle 2237947A74H	DV	1Ø	—	Bolt Tab	6	595
2237262C02M		DV	1Ø	—	#14 - 16	6	
2237262C03M		DV	1Ø	—	#10 - 12	6	
2237262C04M		DV	1Ø	—	#8	6	
2237262C05M		DV	1Ø	—	#6	6	
2237262C16M		DV	1Ø	—	Bolt Tab w/Stud ^c	6	
2237262C51M	Hotstick Handle 2237947A07H or "T" Handle 2237947A74H	DV	1Ø	—	Bolt Tab	8	595
2237262C52M		DV	1Ø	—	#14 - 16	8	
2237262C53M		DV	1Ø	—	#10 - 12	8	
2237262C54M		DV	1Ø	—	#8	8	
2237262C55M		DV	1Ø	—	#6	8	
2237262C66M		DV	1Ø	—	Bolt Tab w/Stud ^c	8	
2237264C01M	Hotstick Handle 2237947A07H or "T" Handle 2237947A74H	DV	1Ø	BP	Bolt Tab	6	597
2237264C02M		DV	1Ø	BP	#14 - 16	6	
2237264C03M		DV	1Ø	BP	#10 - 12	6	
2237264C04M		DV	1Ø	BP	#8	6	
2237264C05M		DV	1Ø	BP	#6	6	
2237264C16M		DV	1Ø	BP	Bolt Tab w/Stud ^c	6	
2237264C51M	Hotstick Handle 2237947A07H or "T" Handle 2237947A74H	DV	1Ø	BP	Bolt Tab	8	597
2237264C52M		DV	1Ø	BP	#14 - 16	8	
2237264C53M		DV	1Ø	BP	#10 - 12	8	
2237264C54M		DV	1Ø	BP	#8	8	
2237264C55M		DV	1Ø	BP	#6	8	
2237264C66M		DV	1Ø	BP	Bolt Tab w/Stud ^c	8	
2237485C01M		DV	1Ø	BP	Bolt Tab	8	819
2238066C01M	Hotstick Handle 2237947A07H	DV	1Ø	SP	Bolt Tab	8	913
2238066C02M		DV	1Ø	SP	#14 - 16	8	
2238066C03M		DV	1Ø	SP	#10 - 12	8	
2238066C04M		DV	1Ø	SP	#8	8	
2238066C05M		DV	1Ø	SP	#6	8	
2237486C10M		DV	1Ø	SP	Bolt Tab	6	787
2237465C01M	Hotstick Handle 2237947A04H or "T" Handle 2237947A70H	CM/DV	1Ø	—	Bolt Tab	6	735
2237465C02M		CM/DV	1Ø	—	#14 - 16	6	
2237465C03M		CM/DV	1Ø	—	#10 - 12	6	
2237465C04M		CM/DV	1Ø	—	#8	6	
2237465C05M		CM/DV	1Ø	—	#6	6	
2237268C01M	Hotstick Handle 2237947A06H or "T" Handle 2237947A73H	TV	1Ø	BP	Bolt Tab	6	603
2237268C02M		TV	1Ø	BP	#14 - 16	6	
2237268C03M		TV	1Ø	BP	#10 - 12	6	
2237268C04M		TV	1Ø	BP	#8	6	
2237268C05M		TV	1Ø	BP	#6	6	
2237268C51M	Hotstick Handle 2237947A06H or "T" Handle 2237947A73H	TV	1Ø	BP	Bolt Tab	8	603
2237268C52M		TV	1Ø	BP	#14 - 16	8	
2237268C53M		TV	1Ø	BP	#10 - 12	8	
2237268C54M		TV	1Ø	BP	#8	8	
2237268C55M		TV	1Ø	BP	#6	8	
2237661C01M	Hotstick Handle 2237947A06H	TV	1Ø	SP	Bolt Tab	8	816
2237674C01M	"T" Handle 2237947A73H	TV	1Ø	SP	Bolt Tab	8	820

a Hardware Kits are not included with the switch, Hardware Kits must be ordered separately.
 b Actuating devices are included in the Hardware Kits.
 c Bolt Tab w/Stud (1/4-20 threaded stud).

d For configuration not found, consult with your factory representative.
 e For abbreviations and definitions see Table 4.

This page intentionally left blank.

This page intentionally left blank.

Eaton
1000 Eaton Boulevard
Cleveland, OH 44122
United States
Eaton.com

Eaton's Cooper Power Systems Division
2300 Badger Drive
Waukesha, WI 53188
United States
Eaton.com/cooperpowerseries

© 2015 Eaton
All Rights Reserved
Printed in USA
Publication No. CA800007EN

Eaton and Cooper Power are valuable trademarks of Eaton in the U.S. and other countries. You are not permitted to use these trademarks without the prior written permission of Eaton.
IEEE Std C57.12 standard is a trademark of the Institute of Electrical and Electronics Engineers, Inc., (IEEE). This publication/product is not endorsed or approved by the IEEE.
Envirotemp™ and FR3™ are licensed trademarks of Cargill, Incorporated.
Viton® is a registered trademark of E.I. DuPont Demours & Company.

For Eaton's Cooper Power series dual voltage switches product information call 1-877-277-4636 or visit: www.eaton.com/cooperpowerseries.