

15 and 25 kV Class standard parking stand arrester installation instructions

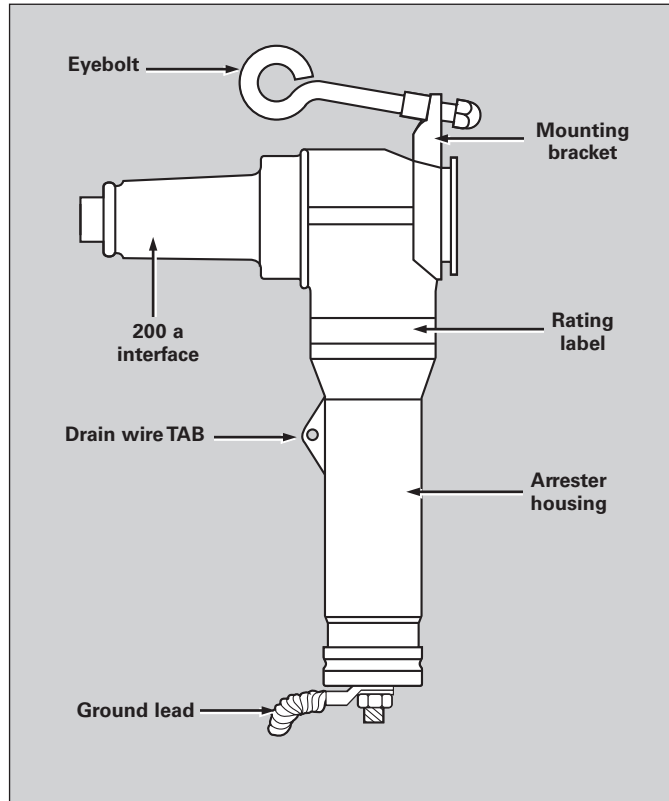

DISCLAIMER OF WARRANTIES AND LIMITATION OF LIABILITY

The information, recommendations, descriptions and safety notations in this document are based on Eaton Corporation's ("Eaton") experience and judgment and may not cover all contingencies. If further information is required, an Eaton sales office should be consulted. Sale of the product shown in this literature is subject to the terms and conditions outlined in appropriate Eaton selling policies or other contractual agreement between Eaton and the purchaser.

THERE ARE NO UNDERSTANDINGS, AGREEMENTS, WARRANTIES, EXPRESSED OR IMPLIED, INCLUDING WARRANTIES OF FITNESS FOR A PARTICULAR PURPOSE OR MERCHANTABILITY, OTHER THAN THOSE SPECIFICALLY SET OUT IN ANY EXISTING CONTRACT BETWEEN THE PARTIES. ANY SUCH CONTRACT STATES THE ENTIRE OBLIGATION OF EATON. THE CONTENTS OF THIS DOCUMENT SHALL NOT BECOME PART OF OR MODIFY ANY CONTRACT BETWEEN THE PARTIES.

In no event will Eaton be responsible to the purchaser or user in contract, in tort (including negligence), strict liability or otherwise for any special, indirect, incidental or consequential damage or loss whatsoever, including but not limited to damage or loss of use of equipment, plant or power system, cost of capital, loss of power, additional expenses in the use of existing power facilities, or claims against the purchaser or user by its customers resulting from the use of the information, recommendations and descriptions contained herein. The information contained in this manual is subject to change without notice.

Contents

DISCLAIMER OF WARRANTIES AND LIMITATION OF LIABILITY I

SAFETY FOR LIFE III

SAFETY INFORMATION III
 Safety instructions iii

PRODUCT INFORMATION 1
 Introduction 1
 Additional information 1
 Acceptance and initial inspection 1
 Handling and storage 1
 Quality standards 1

APPLICATION INFORMATION 2

INSTALLATION INSTRUCTIONS 2



Safety for life



Eaton's Cooper Power series products meet or exceed all applicable industry standards relating to product safety. We actively promote safe practices in the use and maintenance of our products through our service literature, instructional training programs, and the continuous efforts of all Eaton employees involved in product design, manufacture, marketing and service.

We strongly urge that you always follow all locally approved safety procedures and safety instructions when working around high-voltage lines and equipment and support our "Safety For Life" mission.

Safety information

The instructions in this manual are not intended as a substitute for proper training or adequate experience in the safe operation of the equipment described. Only competent technicians who are familiar with this equipment should install, operate, and service it.

A competent technician has these qualifications:

- Is thoroughly familiar with these instructions.
- Is trained in industry-accepted high and low-voltage safe operating practices and procedures.
- Is trained and authorized to energize, de-energize, clear, and ground power distribution equipment.
- Is trained in the care and use of protective equipment such as arc flash clothing, safety glasses, face shield, hard hat, rubber gloves, clampstick, hotstick, etc.

Following is important safety information. For safe installation and operation of this equipment, be sure to read and understand all cautions and warnings.

Hazard Statement Definitions

This manual may contain four types of hazard statements:

DANGER

Indicates an imminently hazardous situation which, if not avoided, will result in death or serious injury.

WARNING

Indicates a potentially hazardous situation which, if not avoided, could result in death or serious injury.

CAUTION

Indicates a potentially hazardous situation which, if not avoided, may result in minor or moderate injury.

CAUTION

Indicates a potentially hazardous situation which, if not avoided, may result in equipment damage only.

Safety instructions

Following are general caution and warning statements that apply to this equipment. Additional statements, related to specific tasks and procedures, are located throughout the manual.

DANGER

Hazardous voltage. Contact with hazardous voltage will cause death or severe personal injury. Follow all locally approved safety procedures when working around high- and low-voltage lines and equipment.

G103.3

WARNING

Before installing, operating, maintaining, or testing this equipment, carefully read and understand the contents of this manual. Improper operation, handling or maintenance can result in death, severe personal injury, and equipment damage.

G101.0

WARNING

This equipment is not intended to protect human life. Follow all locally approved procedures and safety practices when installing or operating this equipment. Failure to comply can result in death, severe personal injury and equipment damage.

G102.1

WARNING

Power distribution and transmission equipment must be properly selected for the intended application. It must be installed and serviced by competent personnel who have been trained and understand proper safety procedures. These instructions are written for such personnel and are not a substitute for adequate training and experience in safety procedures. Failure to properly select, install or maintain power distribution and transmission equipment can result in death, severe personal injury, and equipment damage.

G122.3

⚠ CAUTION

High Voltage. Eaton's Cooper Power series Parking Stand Surge Arrester is designed to be operated in accordance with normal safe operating procedures. These instructions are not intended to supersede or replace existing safety and operating procedures. The Parking Stand Arrester should be installed and serviced only by personnel familiar with good safety practices and the handling of high-voltage electrical equipment. It may be removed from an energized system according to approved utility practices for removal of loadbreak terminators.

Product information

Introduction

Eaton's Cooper Power series MOV design parking stand arresters provide overvoltage protection to underground systems. They are designed to be installed in the parking stand bracket on the frontplate of a transformer or other apparatus.

⚠ Read this manual first

Read and understand the contents of this manual and follow all locally approved procedures and safety practices before installing or operating this equipment

Additional information

These instructions cannot cover all details or variations in the equipment, procedures, or process described nor provide directions for meeting every possible contingency during installation, operation, or maintenance. When additional information is desired to satisfy a problem not covered sufficiently for the user's purpose, please contact your Eaton representative.

Acceptance and initial inspection

Each parking stand arrester is completely assembled, inspected, and tested at the factory. It is in good condition when accepted by the carrier for shipment. Upon receipt of a parking stand arrester inspect it thoroughly for damage and loss of parts incurred during shipment. If damage or loss is discovered, file a claim with the carrier immediately.

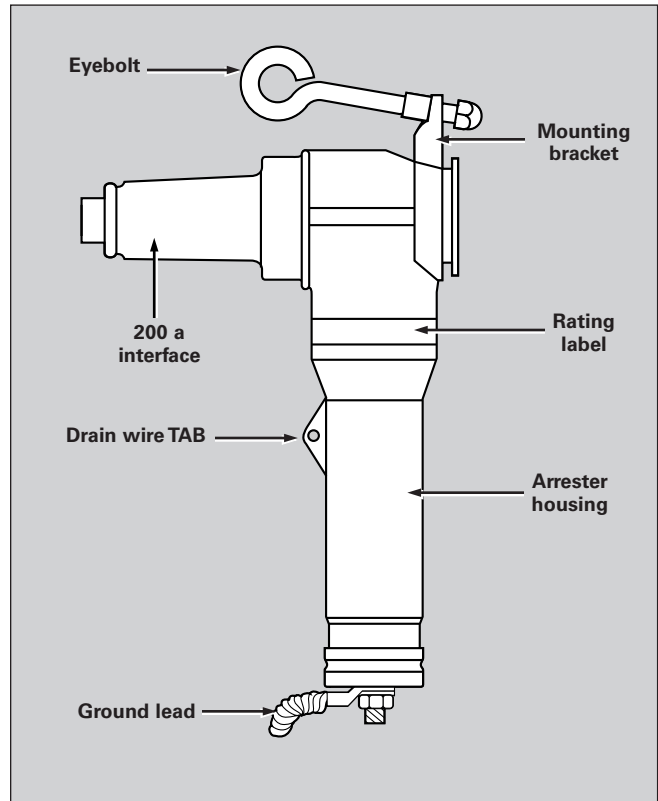

Figure 1. Line illustration of 25 KV parking stand arrester

Handling and storage

If the parking stand arrester is to be stored for an appreciable time before installation, provide a clean, dry storage area.

Quality standards

ISO 9001 Certified Quality Management System

Table 1. Electrical Apparatus - Specifier's Catalog Section Number Reference

Arrester design	Catalog section number
Standard MOV	CA235027EN

Application information

The parking stand arrester should be installed only on systems where the power frequency voltage at the arrester does not exceed maximum continuous operating voltage (MCOV) values published on page 4, Table 2.

The voltage rating and maximum continuous operating voltage are identified on a label on the arrester. If this information does not match the shipping order, please contact your Eaton representative before installation.

CAUTION

High voltage. Do not install an arrester if the voltage and MCOV data listed on the arrester label are not exactly the same as that listed on the carton label. Do not install arrester if system line-to-ground voltage exceeds the MCOV rating on the arrester. Failure to comply may result in minor or moderate injury.

Note: Because the parking stand arrester has a completely grounded case, it may be installed anywhere within the apparatus primary compartment. Determine the space requirements of the arrester and ground lead before installation, operation or removal of other devices.

Installation instructions

Note: Verify parking stand arrester has the proper interface and voltage rating for the application.

Note: When the parking stand arrester is installed on an energized system, it must be positioned so that its grounded end points downward or at an adjacent grounding plane.

Note: Excessive force on the ground lead may cause the metal cap to separate from the arrester housing. Never handle the arrester by the attached ground lead.

Note: The nut attaching the ground lead to the threaded stud on the metal cap is factory installed to the proper torque value. Do not remove or retighten. Over torqueing of the ground lead nut may cause the metal cap to separate from the arrester housing.

- Attach ground lead of arrester (connected to base of arrester) to system ground with 4 to 8 ft-lbs torque.
- Attach drain wire to drain wire tab.
- Lubricate bushing interface of arrester with lubricant supplied.
- Grasp eyebolt on parking stand arrester with clampstick and install on parking stand bracket. Position arrester so that its grounded end points downward or at an adjacent grounding plane. Turn eyebolt clockwise to ensure rigid mounting.

WARNING

High voltage. When not in use, the parking stand arrester must be covered with an insulated protective cap to keep the interface clean and dry. Failure to comply could result in death or serious injury.

- Verify ground lead attachment.
- Grasp pulling eye of loadbreak elbow to be installed on parking stand arrester with clampstick. Remove the loadbreak elbow from the bushing.
- After positioning elbow probe into nosepiece of parking stand arrester bushing, slowly insert elbow into bushing until a slight bump is felt.
- Thrust elbow firmly onto the arrester.
- Cover any exposed bushings with insulated protective caps.

15 and 25 kV Class standard parking stand arrester installation instructions

Table 2. Recommended M.O.V.E. arrester applications

Nominal Circuit Voltage (kV)	Maximum Voltage (kV)	Duty Cycle (MCOV Ratings) (kV)		
		4-Wire Wye; Multi-grounded Neutral	3-Wire Wye; Solidly Grounded Neutral 30 minute ¹	Delta and ungrounded Wye ²
2.4	2.54	—	—	3 (2.55)
4.16 Y/2.4	4.4 Y/2.54	3 (2.55)	6 (5.1)	—
4.16	4.4	—	—	6 (5.1)
4.8	5.08	—	—	6 (5.1)
6.9	7.26	—	—	9 (7.65)
8.32 Y/4.8	8.8 Y/5.08	6 (5.1)	9 (7.65)	—
12.0 Y/6.93	12.7 Y/7.33	9 (7.65)	12 (10.2)	—
12.47 Y/7.2	13.2 Y/7.62	9 (7.65)	15 (12.7)	—
13.2 Y/7.62	13.97 Y/8.07	10 (8.4)	15 (12.7)	—
13.8 Y/7.97	14.52 Y/8.38	10 (8.4)	15 (12.7)	—
13.8	14.52	—	—	18 (15.3)
20.78 Y/12.0	22.0 Y/12.7	15 (12.7)	21 (17.0)	—
22.86 Y/13.2	24.2 Y/13.97	18 (15.3)	24 (19.5)	—
24.94 Y/14.4	26.4 Y/15.24	18 (15.3)	27 (22.0) ³	—
27.6 Y/15.93	29.255 Y/16.89	21 (17.0)	—	—

1. Line-to-ground fault duration not to exceed 30 minutes. For longer durations, contact factory for proper rating.

2. Use for high impedance grounded systems also.

3. The 22.0 kV MCOV rating is available only in the 35 kV Class Large Interface (Interface No. 1).



Eaton
1000 Eaton Boulevard
Cleveland, OH 44122
United States
Eaton.com

Eaton's Power Systems Division
2300 Badger Drive
Waukesha, WI 53188
United States
Eaton.com/cooperpowerseries

© 2016 Eaton
All Rights Reserved
Printed in USA
Publication No. MN235024EN / Rev 0
November 2016

Eaton is a registered trademark.

All trademarks are property
of their respective owners.

For Eaton's Cooper Power series product
information
call 1-877-277-4636 or visit:
www.eaton.com/cooperpowerseries.