

1250 A deadbreak tee connector (M16) - interface D



Related products

- DPC612 Connecting Plug
- DRC600 Receptacle Cap
- DPS600 Standoff Plug
- DPE600 Earthing Plug
- DPR600 Reducing Tap Plug

Installation

- No special tools, heating, taping, or potting are required.
- Connector may be energized immediately after installation on its mating part.
- Mates with bushings, plugs, and junction devices complying with the listed standards.

Application

- For connection of polymeric cable to transformers, switchgear, motors, and other equipment with a premoulded separable connector.
- For indoor and outdoor installation.
- Continuous current 1250 A (1800 A overload for 8 hours).
- For system voltage (Um) to 24 kV .
- Conductor size: 12 kV 70-630 mm²
24 kV 25-630 mm²
- An optional adapter kit is available for use with PILC cables.

Features

- Provides a fully screened and fully submersible connection when mated with the proper bushing or plug.
- Optional capacitive test point allows for an easy check of the circuit status or installation of a fault indicator.
- No minimum phase clearance requirements.
- Mounting can be vertical, horizontal, or any angle in between.
- 100% factory tested.

Standards

- Meets the requirements of CENELEC HD 629.1 S1, IEC 60502-4, and IEEE Std 386™-2006 standard.

Quality

- Manufacturing facility is registered to ISO-9001 by third party audit.
- Routine tests.
- X-ray audit of random samples.

EATON

Powering Business Worldwide

Features and detailed description

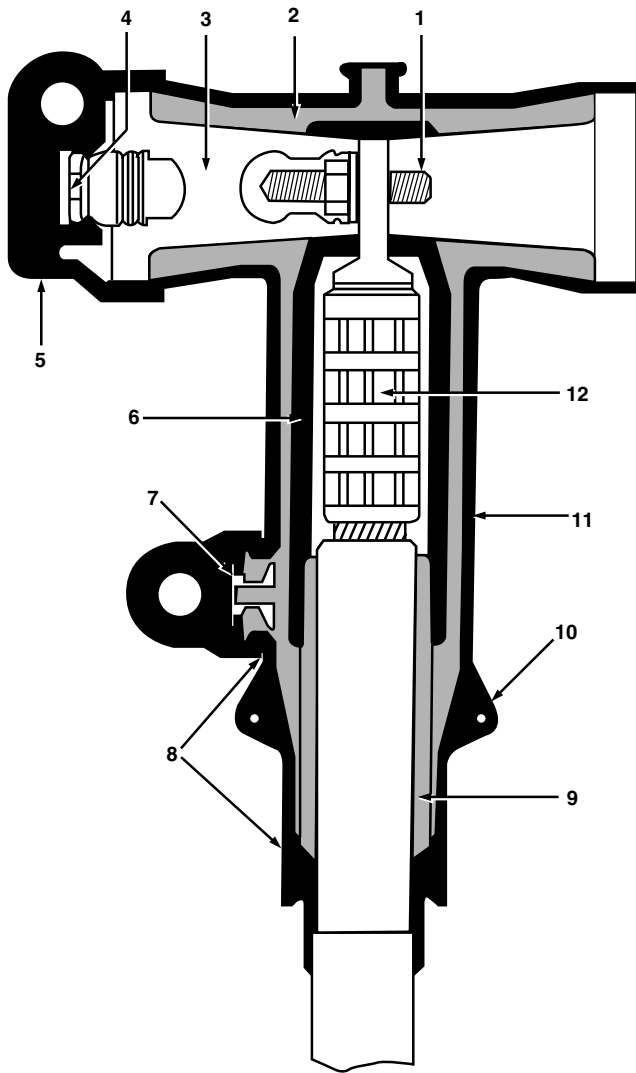

1. **Clamping Screw (M16)**
Tin-plated copper stud and nut secure the contact to the bushing.
2. **Insulation**
Moulded EPDM insulating rubber is formulated and mixed in-house to ensure high quality.
3. **Basic Insulating Plug**
Moulded epoxy part has a threaded metal insert to accept the clamping screw.
4. **Capacitive Test Point**
Capacitive test point provides means to check circuit status.
5. **Rubber Cap**
Moulded EPDM semi-conducting rubber cap protects and earths the test point during normal operation.
6. **Internal Screen**
Moulded EPDM semi-conducting rubber screen controls electrical stress.
7. **Capacitive Test Point (Optional)**
Provides a means to mount a fault indicator or a voltage indicator. A moulded semi-conducting EPDM rubber cap earths the test point when not in use.
8. **Built-in Stress Relief**
The configuration of the external screen and the cable adapter provides cable stress relief.
9. **Cable Adapter**
The sized opening maintains a watertight seal on the cable and provides the initial cable stress relief.
10. **Earthing Eyes**
Moulded into the external screen for connection of one or more earthing wires.
11. **External Screen**
Moulded semi-conducting EPDM rubber maintains screen continuity and ensures that the assembly is at earth potential.
12. **Conductor Contact**
Compression connector accepts copper or aluminum conductors.

Figure 1. 1250 A, 24 kV Class DT612 deadbreak tee connector.

Table 1. Electrical Ratings

Maximum System Voltage (U_m)	24 kV
Partial Discharge Extinction (<3 pC)*	20 kV
Impulse Withstand	125 kV
AC Withstand*	54 kV
Continuous Current	1250 A
Overload (8 hrs.)	1800 A
Short Circuit Withstand, 1 sec. (rms sym.)	75 kA

* Denotes routine tests on 100% of production.

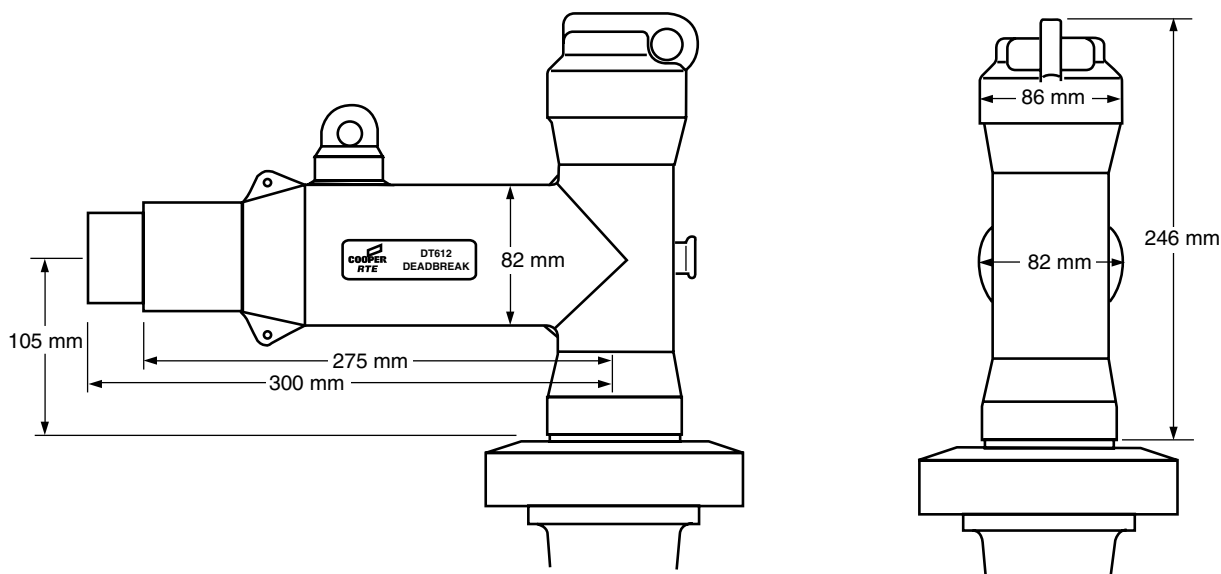

Figure 2. DT612 deadbreak tee connector.

Ordering information

The standard kit is packaged individually in a carton with elbow housing, conductor contact, pin contact and other necessary parts to complete the installation. Cable sealing kits must be ordered separately.

Step 1

Select the insulation diameter code which best centers the insulation diameter of the cable from Table 2.

Step 2

Identify the conductor size and determine the desired connector type from Table 3.

Table 2. Core Insulation Range

Insulation Range Designation	Core Insulation Range (mm)	
	Minimum	Maximum
A	16.3	19.3
B	18.3	21.5
C	19.9	24.6
D	23.1	27.1
E	24.9	29.0
F	27.4	32.5
G	31.0	36.1
H	34.5	39.6
J	37.6	43.2
K	41.6	46.7
L	45.2	49.9

Optional test point

If a test point on the tee body is required, add a "T" before the insulation range designation.

Example: DT612TF240

Ordering Example: For 20 kV cable, 240 mm² aluminum conductor, 31.0 mm core insulation diameter, DIN connector, specify **DT612F240**.

Cable seal adapters are ordered separately.

Table 3. Conductor Code

Stranded Conductor Size (mm ²)	DIN type	EDF type
25	25	E25
35	35	E35
50	50	E50
70	70	E70
95	95	E95
120	120	E120
150	150	E150
185	185	E185
240	240	E240
300	300	E300
400	400	E400
500	500	E500
630		E630

Eaton
1000 Eaton Boulevard
Cleveland, OH 44122
United States
Eaton.com

Eaton's Cooper Power Systems Division
2300 Badger Drive
Waukesha, WI 53188
Eaton.com/cooperpowerseries

© 2015 Eaton
All Rights Reserved
Printed in USA
Publication CA650038EN

Eaton and Cooper Power are valuable trademarks of Eaton in the U.S. and other countries. You are not permitted to use these trademarks without the prior written consent of Eaton.