

Underground Distribution Switchgear

Functional Specification Guide

Type RVAC, Vacuum Break Switchgear

PS285004EN

Functional Specification for 15 kV, 25 kV, or 35 kV Underground Distribution Switchgear

1. Scope

- 1.1. This specification applies to three-phase, [select #] - way [select # -source, select # -tap], 50-60 Hz, fully dead front, sectionalizing underground distribution switchgear; with maximum main bus rating of [select: 200 or 600] amperes continuous current and maximum tap rating of [select: 200 or 600] amperes. Source switching shall be accomplished with vacuum switches. Tap overcurrent protection shall be accomplished utilizing drawout under-oil current limiting fuses (liquid dielectric only). [select: The unit shall have provisions for motor operators to be added to all ways, the unit shall have motor operators on all the ways, or the unit shall be manually operated].
- 1.2. The unit is to be insulated with [select: E200 less-flammable fluid for operation to minus 30 degrees C, Envirotemp™ FR3™ less-flammable fluid for operation to 0 degrees C (32 degrees F), mineral oil for operation to minus 30 degrees C, or SF₆ for operation to minus 30 degrees C] dielectric, contained in a sealed tank design, so operation is unimpaired by flood conditions or contaminated environments (except control). The unit shall utilize vacuum switches for loadbreak switching such that the dielectric media is not consumed or contaminated by normal operations of the vacuum switches. The unit shall be designed for installation on a concrete or fiberglass pad at ground level.
- 1.3. This specification shall only cover the purchase and shipment of switchgear. The purchaser and/or user shall be responsible for all site-work, electrical connections, and installation.

2. Applicable Standards

- 2.1. IEEE Std C37.74™-2003 standard – IEEE Standard Requirements for Subsurface, Vault, and Pad-Mounted Load-Interrupter Switchgear and Fused Load-Interrupter Switchgear for Alternating Current Systems Up to 38 kV
- 2.2. IEEE Std C57.12.28™-2005 standard – IEEE Standard for Pad-Mounted Equipment - Enclosure Integrity
- 2.3. IEEE Std C57.12.29™-2005 standard – IEEE Standard for Pad-Mounted Equipment - Enclosure Integrity for Coastal Environments – applicable when stainless steel construction is specified
- 2.4. IEEE Std 386™-2006 standard – IEEE Standard for Separable Insulated Connector Systems for Power Distribution Systems Above 600 V
- 2.5. IEC 801-3 – Radiated Electromagnetic Field Requirements
- 2.6. IEC 68-2-30 – Environmental Testing

3. Ratings

3.1. The switchgear shall be rated as follows:

Nominal Voltage	15kV	25kV	35kV
Maximum Design Voltage.....	15.5	27	38
BIL.....	95	125	150
1-minute Withstand Switch* and Terminators...	35	60	70
Continuous Current, amps.....	600	600	600
Load Switching, amps.....	600	600	600
Momentary Current 10 Cycles, amps (asym.).....	20,000	20,000	20,000
1 Sec., amps (sym.).....	12,500	12,500	12,500
3 Shot Make and Latch amps (asym.).....	20,000	20,000	20,000
Interrupting Rating** (kA).....	50	20-50	12.2 - 50

* The withstand rating of the switch is higher than that of the connectors (IEEE Std C37.74™-2003 standard).

**Interrupting rating is dependent on the selected fuses and the application voltage

3.2. The switchgear shall have an ambient operating temperature range of -30 °C to +40 °C.

4. Construction

4.1. The underground distribution switchgear shall consist of a 2-sided, sealed insulation tank, and separate front and rear cable compartments. Overall height, width, depth and layout shall conform to the manufacturer's standard construction practices for the configuration, ratings, and voltage class specified. Standard construction shall be of [select: mild steel with stainless steel hardware or 100% 304L stainless steel].

4.2. [select: The liquid filled unit shall have a tamperproof bolted tank cover design, utilizing Buna-N rubber gaskets, or the SF₆ filled tank shall be of welded construction with a welded cover]. The sealed tank (with deadfront terminators installed) shall be capable of withstanding flood immersion while energized, and shall be impervious to contaminants and animals, so as not to compromise the main insulation structure. The cable compartments shall be located at the front and back of the tank respectively. The main cable compartments may house a combination of source way(s) and load or tap way(s). All switch operating handles shall be located on the same front plate as the ways that they operate, in order to reduce the likelihood of operating an incorrect switch. Recessed lifting provisions for suitable balanced lift shall be provided on the tank ends.

4.3. Cable compartments shall both have a minimum depth of [select: 16, 22, 26 or 30 inches], to provide ease of cable installation and allow for the addition of termination accessories.

4.4. Side-hinged cabinet style doors shall be provided. The side-hinged doors shall provide three-point latching and shall not require a center support post. Side-hinged doors shall have a door stay to manually latch the door in the open position at approximately 120° from the closed position. The right hand door on each side shall be the first opening door and shall be secured with a recessed stainless steel pentahead bolt, with provisions for padlocking. The cabinets shall be equipped with a hinged cabinet top to facilitate entry to the cable compartments; it shall open approximately 60 degrees and have door stays to hold it in the open position. The cabinet top when in the closed position shall interlock with the cabinet doors without additional means required to secure it. Cabinet construction shall meet all NEMA and ANSI security requirements as defined in the IEEE Std C57.12.28™-2005 standard and the construction requirements of the IEEE Std C37.74™-2003 standard.

4.5. Units shall be shipped complete with [select: E200 less-flammable fluid for operation to minus 30 degrees C, Envirotemp™ FR3™ less-flammable fluid for operation to 0 degrees C (32 degrees F), mineral oil for operation to minus 30 degrees C, or SF₆ for operation to minus 30 degrees C].

- 4.6. Select below based on insulation requirements.
- 4.7. [select: for liquid dielectric switchgear, The unit shall be equipped with a 1-inch oil-fill plug and a 1-inch drain plug with 3/8" sampler. A single automatic pressure relief valve shall be supplied that is hotstick-operable and located on the source-side front plate above the oil level indicator within the switchgear. The unit shall have sight gages to monitor the dielectric level located on each unit side equipped with an operating handle.]
- 4.8. [select: SF₆ insulated units shall be equipped with a pressure gauge and a self-sealing SF₆ fill valve. A pressure versus temperature chart shall be provided as a decal on the front plate of the tank to aid in determining that proper SF₆ gas pressure levels are present.]
- 4.9. [select: A 1/2-13 UNC stainless steel ground nut shall be provided that is welded to the switchgear tank and mounted beneath each bushing, or, The manufacturer shall provide a factory assembled 1/2-inch diameter copper ground rod in each compartment, for use with user's grounded clamps, that shall provide a 3 inch clearance from the ground rod to the front plate of the tank to accommodate grounding of the insulated connectors.]
- 4.10. A non-corrosive operating diagram (one-line schematic of the unit) shall be affixed to the inside of the right hand, first opening door, on both sides of the unit, if two (2) sided. When visible break switches are specified, the one-line schematic will also show the electrical connection and mechanical interlock of these switches. A single nameplate shall be provided that is mounted on the source side tank front plate in the upper right hand corner. [select if applicable: The switching current and voltage ratings on this nameplate shall also apply to the visible break switch.] The nameplate shall contain the following information:
- Catalog Number/Model Number
 - Serial Number
 - Nominal voltage class, kV
 - Rated maximum voltage, kV
 - BIL, kV
 - Manufacturing Date: MM/YYYY
 - Rated continuous current, A
 - Rated load interrupting rating, A
 - Momentary current rating, kA asym.
 - Close & latch rating, kA asym.
 - Total weight, lbs.
 - Liquid dielectric volume (gallons) – Liquid-Filled Units Only
 - SF₆ Weight, Pressure – SF₆ Units only
- 4.11. Three (3) Faulted Circuit Indicator mounting provisions shall be provided in the sills beneath the cabinet doors at the position of each way. The provisions shall include a 1-1/16 diameter hole sized for Eaton's Cooper Power series type S.T.A.R. fault indicator small remote display, cover plate, and tamperproof mounting bolts. There shall be provisions for mounting at least one fault indicator for each equipment bushing.
- 4.12. **Bushings**
- 4.12.1. Bushings shall be deadfront type for use with separable connectors conforming to IEEE Std 386™-2006 standard and ANSI Standard C119.2. The source ways shall have a continuous current rating of [select: 600 ampere with bushings, or 200 ampere with wells for bushing inserts]. Tap ways shall have a continuous current rating of [select: 600 ampere with bushings, or 200 ampere with wells for bushing inserts.]
- 4.12.2. [select: Six hundred (600) ampere bushings, or The two-hundred (200) ampere wells] shall be horizontally configured at 24 inches above the pad and accept molded, separable deadfront

connectors. Bushings shall be mounted with minimum spacing of 8.0-inches between centerlines, except between the C-phase bushings which may be a minimum of 7.0-inches. A standoff bracket or parking stand shall be supplied for each bushing and shall be mounted horizontally adjacent to each bushing on a 4.0-inch centerline from the bushing centerline. The standard phasing of the bushings from left to right shall follow the sequence ABC-CBA. Each bushing shall have identification affixed to the front plate identifying its source or tap designation, as shown on the one-line operating diagram, and its phase identification.

4.12.3. Where 35 kV rated switchgear with 200-amp sources or taps are specified, [select: Eaton's Cooper Power series one-piece, loadbreak, large interface, integral bushings shall be supplied, or, bushing wells shall be supplied for use with small interface, user furnished, inserts.]

4.12.4. Bushings and bushing wells shall be externally replaceable on SF₆-filled units and shall not require removal of the tank cover or welding to remove or install replacements.

4.13. Source Switches

4.13.1. Source Switches shall utilize vacuum interruption only, such that the dielectric media is never contaminated by switching arc products. Switches shall be three-phase gang-operated vacuum switches that meet or exceed the performance requirements of IEEE Std C37.74™-2003 standard. The mechanism and the vacuum interrupters employed shall be capable of interrupting the rated continuous current [select: 600 amperes, or 200 amperes]. The switch shall have a single operating handle, designed for operation with a lineman's hotstick, which has a push to close / pull to open operation. Operation of the handle shall require no more than 75 lbs. of force and 60 degrees of movement for complete operation. The mechanism shall close the switch independently of the operator's speed of moving the handle. The switch, as a safety feature, shall close into a fault and remain closed at any current up to its full rating. Switch operating handles shall be front plate mounted and shall be padlockable in both the open and closed positions.

5. [select: Visible Break Switch (600 A or less, liquid filled, non-fused units only)]

5.1. A separate, interlocked, visible break switch shall be provided in each circuit specified. [select: The visible break switch shall be 2 position (Open/Closed), or 3 position (Open/Closed/Cable Ground). The visible break option will consist of an isolating switch, in series with the vacuum switch, which meets all of the continuous current and voltage ratings of the switchgear. The contacts of the visible break switch will be clearly visible through a 4" x 11" view window manufactured of a clear material with an impact strength rating of "Excellent". The vacuum switches and their corresponding visible break switches shall be mechanically interlocked such that the visible break switch will never operate under load. All current interruption shall be by the vacuum interrupters. For 4-way units, the visible break switches shall be operated from the side of the switchgear via a rotary style hot stick operable handle. The operating handles for optional visible break switches shall be located at the sides of the switchgear tank inside padlockable "side-pockets". These "side pockets" shall be bolted shut using pentahead bolts and shall house T-Handles for operation of the rotary style visible break switch handles. [On 5 (five) and 6 (six) way units the center switches may be front-operable.]

6. Fusing

6.1. Overcurrent protection shall be provided by Eaton's Cooper Power series types ELSG under-oil full range current limiting fuses that shall be mounted in Eaton's Cooper Power series type ELSG wet well drawout fuseholders.

6.2. Fusing available only on liquid insulated switchgear – not on SF₆.

6.3. 15 kV rated switchgear shall be provided with fuseholders that accept 8.3 kV maximum rated fuses. 25 kV rated switchgear shall be provided with fuseholders that accept 15.5 kV or 23.0 kV maximum rated fuses. 35 kV rated switchgear shall be provided with fuseholders that accept 23.0 kV maximum rated fuses.

Note: 15 kV delta = use 25 kV rated switchgear

6.4. The switchgear shall be provided with fuseholders only unless otherwise specified.

7. Finish Performance Requirements:

7.1. The switchgear shall be constructed of mild steel with stainless steel details and painted green conforming to Munsell 7GY 3.29/1.5. The coating system employed shall meet or exceed IEEE Std C57.12.28™-2005 standard coating system requirements for underground distribution equipment, including the following performance tests:

- 1500-hour 5% salt spray corrosion test per ASTM B117 / D1654
- 1000-hour humidity test per ASTM D2247 / D1654
- 500-hour ultraviolet accelerated weathering test per ASTM G53 / D523
- Direct impact test with 160 in. lb. falling dart per ASTM D2794
- Tabor abrasion test 3,000 cycles per ASTM D4060
- Crosshatch adhesion per ASTM D3359

7.2. [select (additionally): for stainless steel], The switchgear and its compartments shall be constructed of 100% 304L stainless steel painted green conforming to Munsell 7GY 3.29/1.5. The coating system employed shall meet or exceed IEEE Std C57.12.29™-2005 standard coating system requirements for underground distribution equipment in coastal environments.

8. [select: Optional Features]

8.1. Motor Operator Mounting Provisions

8.1.1. When specified, the source vacuum switches shall be provided with mounting provisions for future addition of motor operators. The provisions shall include auxiliary switches with one "a" and one "b" contact, mounting studs for motor operator mounting brackets, switch operating handles with provision for attachment to motor operators, studs and channels for routing cable connections to the future motor operator control, stud mounting provisions on the inside of one of the cabinet doors (standard location) for the future motor control, and a minimum of a 30-inch deep cabinet that shall have side-hinged doors.

8.2. Motor Operators

8.2.1. When specified, DC motor operators, with control shall be supplied for the vacuum switches. The unit shall include all standard motor operator mounting provisions specified above. The motor operators shall utilize 24 Vdc motor actuators to open and close the respective switch. The time required to open or close a switch shall be approximately 8 seconds. The motor control shall be equipped with a 2.5 amp-hour sealed lead acid gel-cell battery to supply energy to activate the motor operators and control functions. Battery charge shall be maintained by a temperature/voltage regulated charger within the motor control that shall be capable of fully re-charging a low battery within 24 hours.

8.2.2. The motor control shall utilize a user supplied 120-Vac two-wire grounded supply. [optional: The control shall also have provisions for accepting a second, alternate 120 Vac supply and shall provide a transfer relay to transfer to the alternate supply if the primary 120 Vac supply is lost.] If an internal potential transformer for power supply to the motor control has been specified (see below), the unit shall be provided with all necessary wiring factory installed.

8.2.3. The motor control shall include the following features:

- The motor control shall be capable of operating up to six motor actuators, one at a time. A local selector switch shall be provided on the control panel to select the motor actuator that is to be operated.

- Open, Close, and Stop pushbuttons shall be provided for operation of the selected motor actuator.
- Open and Closed indicating lights shall be provided to indicate status of the selected switch. These status lights shall use auxiliary switch inputs from the source vacuum switch to determine open or closed status.
- Opening and closing indicating lights shall be provided to verify that the selected motor actuator is in process of opening or closing a switch. A lamp test pushbutton shall be provided to confirm that indicating lights are functional
- A Power On/Off toggle switch shall be provided that shall disconnect the dc voltage supply from the control and any selected motor actuators and shall function as a dc circuit breaker to interrupt the dc supply in the event of a short circuit or overload.
- An indicator shall be provided to verify that 120 Vac power is present and that the battery charging circuit is providing a charging voltage to the battery. A battery test pushbutton shall be supplied with test points to apply a voltmeter for testing the condition of the battery.
- A Local/Remote toggle switch shall be provided. In the Local position, the switch shall allow operation of the motor actuators by the pushbuttons on the control panel only and shall not allow remote or SCADA operation. In the Remote position, the switch shall only respond to the remote or SCADA operation of the motor actuators.
- The control shall include a terminal strip for connection to SCADA or remote control equipment. The terminal strip shall have connections for selecting a motor actuator with a maintained dry contact input, reading the Open/Closed status of the associated switch, initiating a Open or Close operation via a momentary dry contact, and reading the Opening/Closing status of the motor actuator as it performs the required operation.
- [select: The control shall also include provisions to add a hand-held extended control accessory and an interconnecting cable (length to be specified, maximum is 200 ft.). This accessory shall provide the same motor selection and operating pushbuttons as the main control that is mounted with the switchgear so as to temporarily allow operation of the motor actuators from a more remote and convenient location.]
- An electrical interlock shall exist to coordinate the operation of any motor controlled switch with any separately specified visible break switch.
- [select: Optional provisions, such as an internal potential transformer (to 25 kV) for power supply to the motor control, shall be supplied only when specified as a requirement for a liquid-insulated unit.]

8.3. Internal PT Power

- 8.3.1.** When specified, an internal single-phase potential transformer (liquid-insulated designs only) shall be provided that shall be connected to the “B phase” of the common bus and protected against potential transformer failure by an under-oil primary current-limiting fuse. The transformer primary shall be rated at [select: line-to-ground connection and voltage, or, specify: line-to-line connection and voltage] and provide a 120 Vac secondary voltage output. [select: Primary and secondary connections shall be grounded wye, or Primary connection shall be phase-to-phase and secondary grounded wye. The potential transformer shall be wired to the MIL C-5015 style connector that is provided for the auxiliary switch connections. The potential transformer shall provide power for the [select: future motor, or motor] operators. For units with a bus tie switch a PT shall be supplied on each side of the tie switch such that power shall be available should one-half the bus be energized – the control circuits shall contain a power transfer relay so that the inactive bus half will not be reverse energized by the control circuits.

8.4. Open/Closed Semaphores

- 8.4.1.** When specified, an Open (green) /Closed (red) semaphore shall be provided for each way, which shall indicate the open or closed status of the vacuum switches. The semaphore shall be mounted internally and shall be directly linked to the movable contact rod of the vacuum switch. The semaphore shall be visible through a window on the tank in direct logical proximity to the operating handle of its vacuum switch.

8.5. Interlocks

8.5.1. When specified, mounting provisions for Kirk key interlocks shall be provided on each switched way. The actual interlocking key scheme and the interlocks will be furnished by the purchaser.

8.6. Auxiliary Switches

8.6.1. When specified, the source vacuum switches shall be provided with two stage “a” and two “b” auxiliary switches for the purpose of remote indication of status. The auxiliary switches shall be linked to the movable contact rod of the vacuum switch and shall be internally pre-wired to a MIL C-5015 style circular power connector receptacle, mounted on the front plate. The receptacle shall be provided with a mating plug for user’s cable termination. These auxiliary switches shall be rated for 15 amps @ 120 Vac / 1 amp @ 125 Vdc.

8.7. Operations Counters

8.7.1. When specified, an operations counter shall be supplied, externally mounted and mechanically linked to the operating handle of each way.

8.8. Special Certifications

8.8.1. When specified, a UL[®] listed and labeled product shall be provided with the following features meeting requirements for UL[®] listing and labeling:

- Voltage rating classes of 15 kV and 25 kV
- Non-fused unit
- Fluid Dielectrics (mineral oil, E200, and Envirotemp™ FR3™ fluids)
- Visible-break (two- and three-position)
- Standard ground pads
- Mild and stainless steel construction
- Semaphores
- 600 A bushings or 200 A bushing wells and inserts

8.9. 200 ampere bushing well switch module inserts.

8.10. Fault indicator mounting provisions located on the source and tap compartment door sill.

8.11. Spare fuse storage rack.

9. **Certified Design Test Data:**

9.1. Certified design test data shall be furnished upon request. The test data shall be available for the following:

9.2. Switch ratings per IEEE Std C37.74™-2003 standard.

9.3. Coatings per [select: IEEE Std C57.12.28™-2005 or IEEE Std C57.12.29™-2005 standard.]

10. **Production Testing** - The unit shall be subjected to the following production tests:

10.1. Continuity test to assure correct internal connections.

10.2. Hi-pot test to determine dielectric strength of the unit.

10.3. Pressure test to assure tank is completely sealed.

11. **Submittals**

11.1. The manufacturer shall furnish a detailed list of ratings and accessories and set of drawings defined as follows [select optional: drawings for approval] :

- Detailed front elevation.
- Single Line
- Base Plan
- Schematics

11.2. The manufacturer shall furnish instruction manuals covering the installation of the switchgear and the operation of its various components.

12. Quality Assurance

12.1. The manufacturer shall be a company specializing in medium voltage underground distribution switchgear with at least fifteen years of documented experience.

12.2. Equipment shall be built in accordance with the industry standards for medium voltage equipment.

12.3. The manufacturer shall be registered and certified as ISO 9001 compliant by a recognized international and independent body.

13. Warranty

13.1. The underground distribution switchgear shall be provided with a one-year warranty in-service/18 months maximum from date of shipment.

14. Approved Manufacturers

Eaton

APPENDIX A: MODELS AND WAYS

These notes are for the user of this specification guide and are not intended to be a part of the specification.

Definitions:

WAY - A “way” is defined as a connection from the exterior (either a source or a tap) to the interior switchgear bus that may be a direct electrical connection or a connection via switch or a fuse. The total number of “ways” is the sum of all sources and taps. An internal bus tie switch is not a way.

MODEL or MODEL NUMBER – A shorthand method to describe a bus arrangement that includes sources, taps and tie switches that further defines the presence of switches, fuses, and direct connections to the bus. This allows one to describe bus common arrangements without creating or transmitting drawings. Typical model number arrangements follow; these may be modified to accommodate any possible arrangement of the circuit elements.

INSERT A MODEL DIAGRAM INTO THE SPECIFICATION FROM THIS LIST OR CREATE A SKETCH (maximum of 6 ways, total):

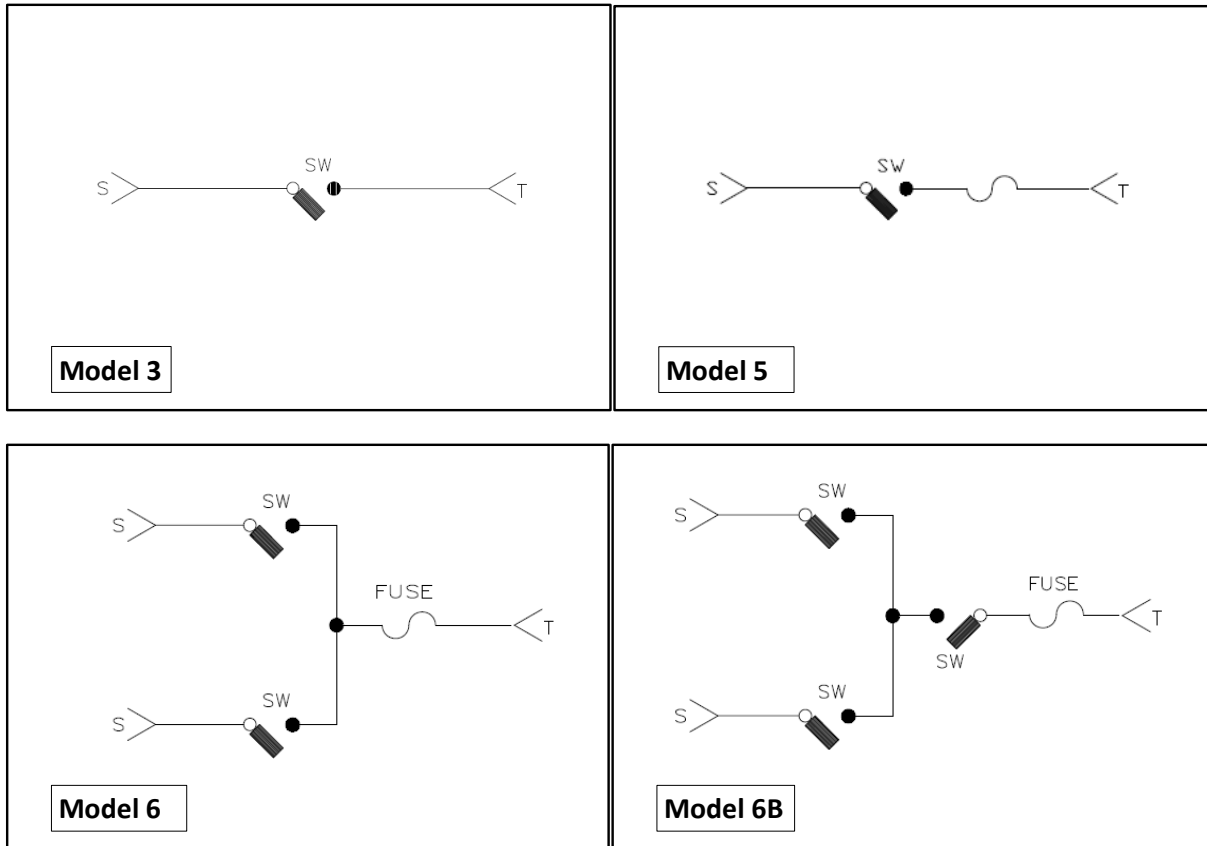

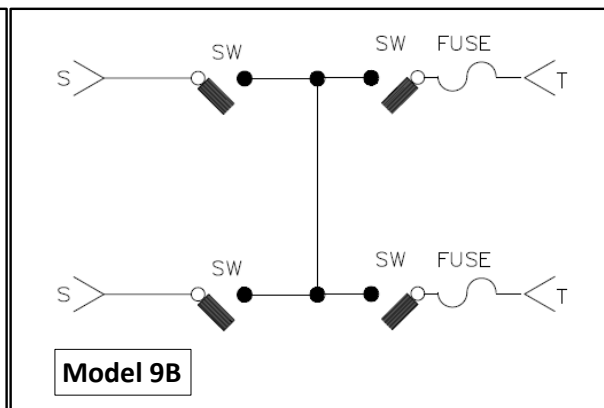
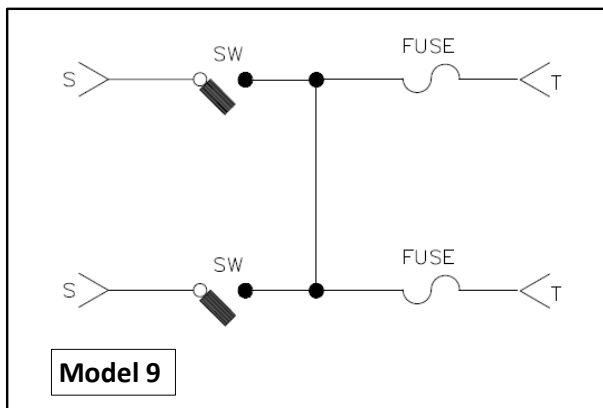
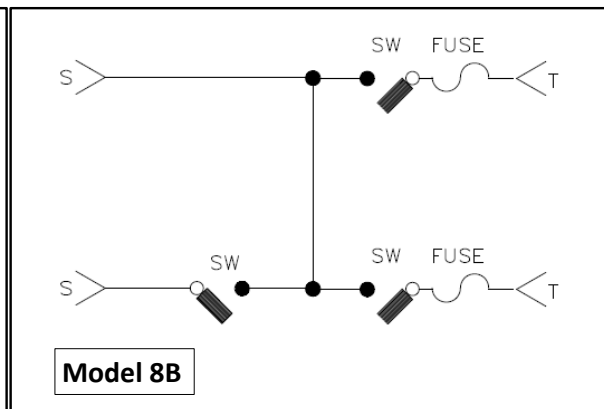
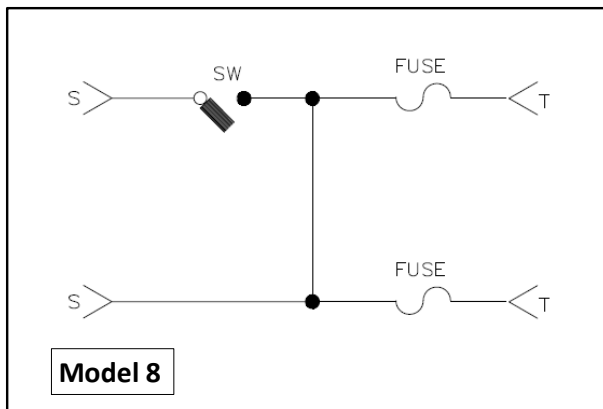
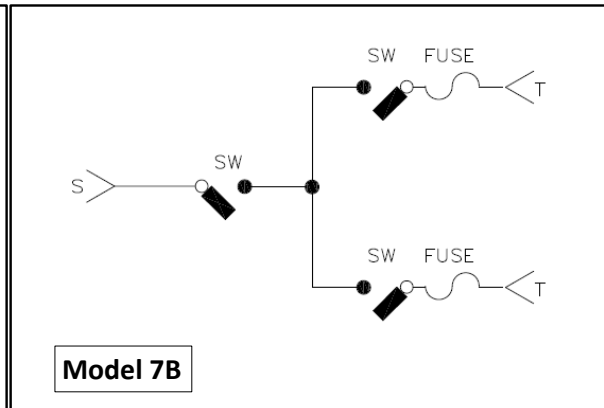
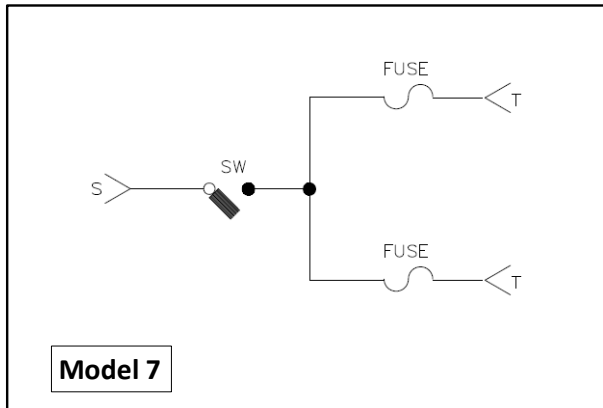

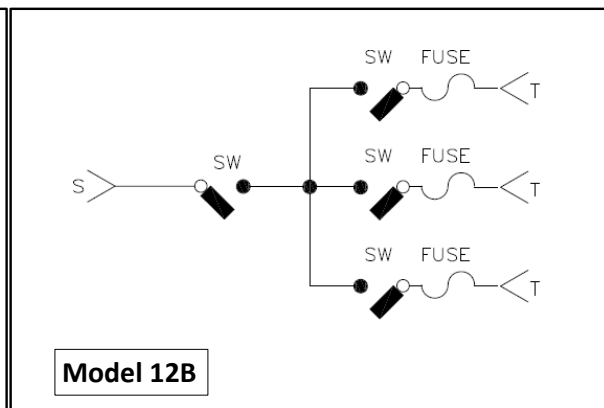
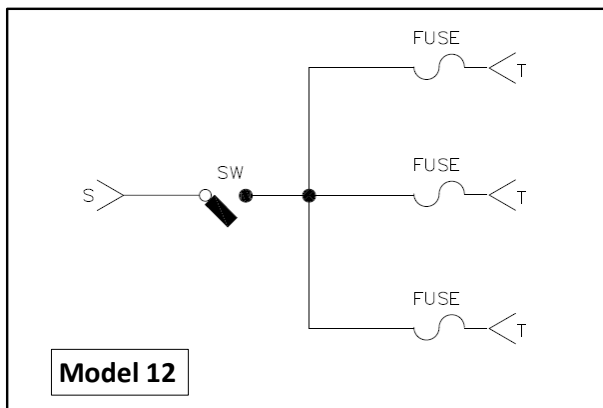
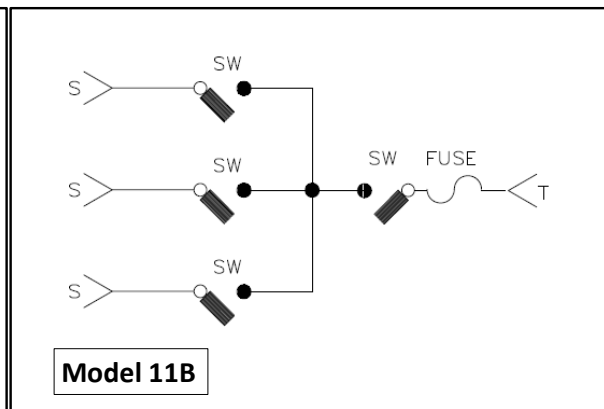
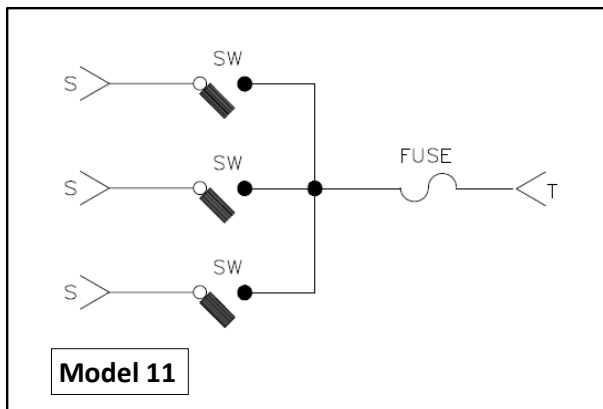
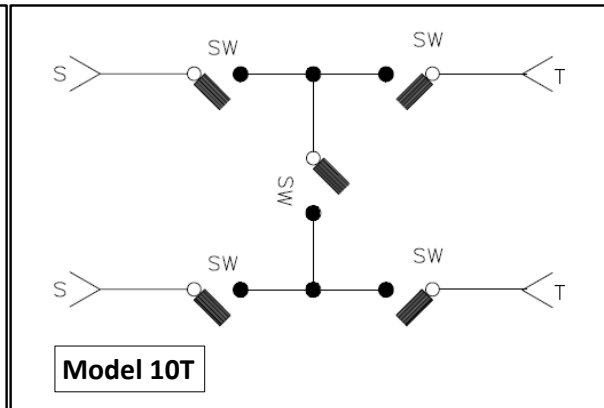
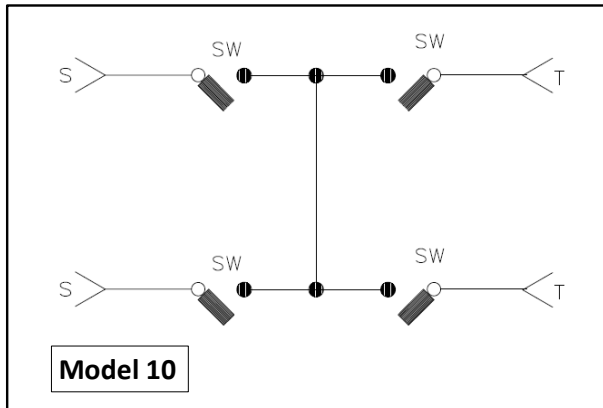

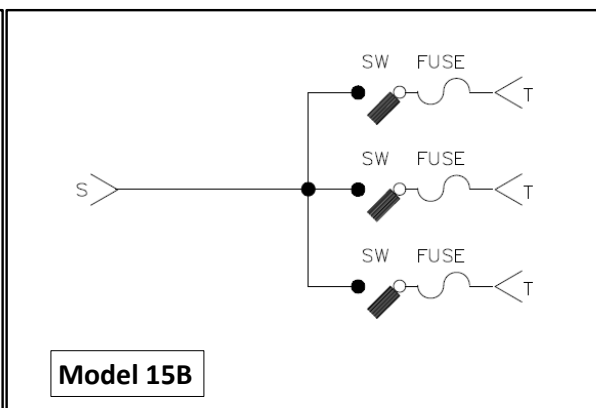
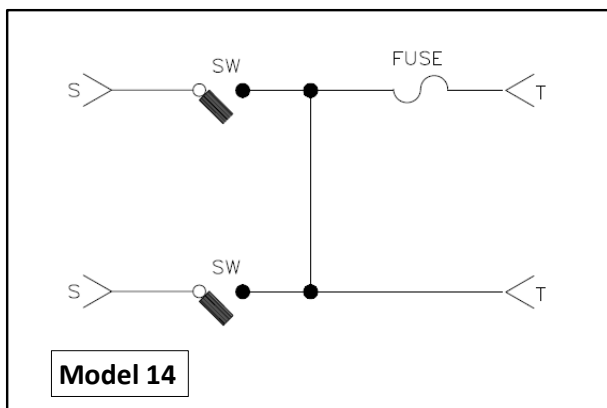
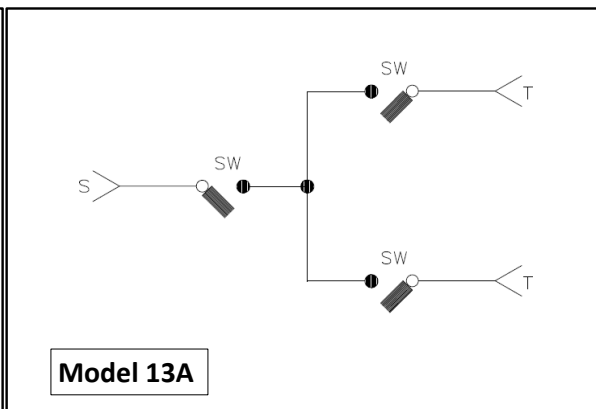
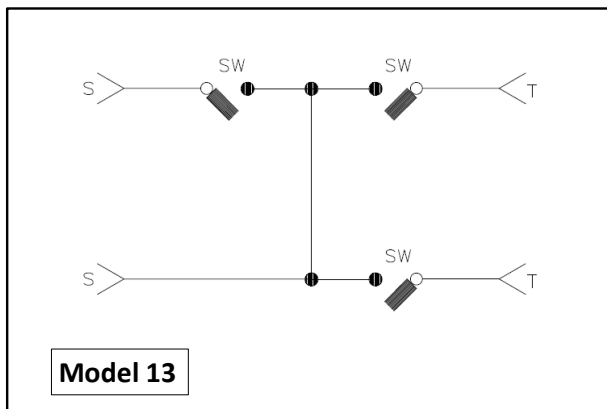

Envirotemp™ and FR3™ are licensed trademarks of Cargill, Incorporated.