

Type PST Model-9 Automatic Source Transfer Switchgear with iST Control; Installation, Operation, and Maintenance Instructions



Powering Business Worldwide

DISCLAIMER OF WARRANTIES AND LIMITATION OF LIABILITY

The information, recommendations, descriptions and safety notations in this document are based on Eaton Corporation's ("Eaton") experience and judgment and may not cover all contingencies. If further information is required, an Eaton sales office should be consulted. Sale of the product shown in this literature is subject to the terms and conditions outlined in appropriate Eaton selling policies or other contractual agreement between Eaton and the purchaser.

THERE ARE NO UNDERSTANDINGS, AGREEMENTS, WARRANTIES, EXPRESSED OR IMPLIED, INCLUDING WARRANTIES OF FITNESS FOR A PARTICULAR PURPOSE OR MERCHANTABILITY, OTHER THAN THOSE SPECIFICALLY SET OUT IN ANY EXISTING CONTRACT BETWEEN THE PARTIES. ANY SUCH CONTRACT STATES THE ENTIRE OBLIGATION OF EATON. THE CONTENTS OF THIS DOCUMENT SHALL NOT BECOME PART OF OR MODIFY ANY CONTRACT BETWEEN THE PARTIES.

In no event will Eaton be responsible to the purchaser or user in contract, in tort (including negligence), strict liability or otherwise for any special, indirect, incidental or consequential damage or loss whatsoever, including but not limited to damage or loss of use of equipment, plant or power system, cost of capital, loss of power, additional expenses in the use of existing power facilities, or claims against the purchaser or user by its customers resulting from the use of the information, recommendations and descriptions contained herein. The information contained in this manual is subject to change without notice.

Contents

DISCLAIMER OF WARRANTIES AND LIMITATION OF LIABILITY	ii
SAFETY INFORMATION	v
Safety instructions	v
PRODUCT INFORMATION	1
Introduction	1
Acceptance and initial inspection	1
Handling and storage	1
Standards	1
Quality standards	1
PST MODEL-9 OVERALL DESCRIPTION	1
Vacuum interrupters	2
Bushings	2
Standard cabinet features	2
Interrupter duty cycle	4
Switch test sequence	4
Nameplate	4
Operating handles	4
Weight	4
RATINGS AND SPECIFICATIONS	5
LOAD TRANSFER FUNCTIONALITY	5
iST control operation	5
Operation of interval timer	9
CI switch	10
Operating modes	10
CI operating sequences	10
Manual operation of CI switches	11
OVERCURRENT PROTECTION FUNCTIONALITY	11
Vacuum fault interrupters (VFI)	12
Manual VFI operation	12
Opening VFI switches	13
Resetting VFI switches	13
Closing VFI switches	13
INSTALLATION PROCEDURES	13
Initial mechanical operation check	14
Initial electrical operation check	15
Initial iST control operation check	16

MAINTENANCE17

- Maintenance inspection procedure 17
- Internal inspection and repair 18
- Insulating fluid maintenance 18
- Frequency of maintenance 19
- Types of fluid samples. 19
- Fluid sampling guidelines 19
- Fluid fill guidelines. 20
- Fluid testing. 21
- Dissolved gas analysis. 21

TESTING22

- High-potential withstand testing of vacuum interrupters 22

REPLACEMENT PARTS22



Safety for life



Eaton meets or exceeds all applicable industry standards relating to product safety in its Cooper Power™ series products. We actively promote safe practices in the use and maintenance of our products through our service literature, instructional training programs, and the continuous efforts of all Eaton employees involved in product design, manufacture, marketing, and service.

We strongly urge that you always follow all locally-approved safety procedures and safety instructions when working around high-voltage lines and equipment, and support our “Safety For Life” mission.

Safety information

The instructions in this manual are not intended as a substitute for proper training or adequate experience in the safe operation of the equipment described. Only competent technicians who are familiar with this equipment should install, operate, and service it.

A competent technician has these qualifications:

- Is thoroughly familiar with these instructions.
- Is trained in industry-accepted high- and low-voltage safe operating practices and procedures.
- Is trained and authorized to energize, de-energize, clear, and ground power distribution equipment.
- Is trained in the care and use of protective equipment such as arc flash clothing, safety glasses, face shield, hard hat, rubber gloves, clampstick, hotstick, etc.

Following is important safety information. For safe installation and operation of this equipment, be sure to read and understand all cautions and warnings.

Hazard Statement Definitions

This manual may contain four types of hazard statements:

DANGER

Indicates an imminently hazardous situation which, if not avoided, will result in death or serious injury.

WARNING

Indicates a potentially hazardous situation which, if not avoided, could result in death or serious injury.

CAUTION

Indicates a potentially hazardous situation which, if not avoided, may result in minor or moderate injury.

NOTICE

Indicates a potentially hazardous situation which, if not avoided, may result in equipment damage only.

Safety instructions

Following are general caution and warning statements that apply to this equipment. Additional statements, related to specific tasks and procedures, are located throughout the manual.

DANGER

Hazardous voltage. Contact with hazardous voltage will cause death or severe personal injury. Follow all locally-approved safety procedures when working around high- and low-voltage lines and equipment.

G103.3

WARNING

Before installing, operating, maintaining, or testing this equipment, carefully read and understand the contents of this manual. Improper operation, handling, or maintenance can result in death, severe personal injury, and equipment damage.

G101.0

WARNING

This equipment is not intended to protect human life. Follow all locally-approved procedures and safety practices when installing or operating this equipment. Failure to comply can result in death, severe personal injury, and equipment damage.

G102.1

WARNING

Power distribution and transmission equipment must be properly selected for the intended application. It must be installed and serviced by competent personnel who have been trained and understand proper safety procedures. These instructions are written for such personnel and are not a substitute for adequate training and experience in safety procedures. Failure to properly select, install, or maintain power distribution and transmission equipment can result in death, severe personal injury, and equipment damage.

G122.2

Type PST Model-9 Automatic Source Transfer Switchgear with iST Control

This page is intentionally left blank.

Product information

Introduction

Service Information MN285002EN provides installation instructions, operation information, maintenance procedures, and testing information for Eaton's Cooper Power™ series Type PST Model-9 Underground Distribution Automatic Source Transfer Switchgear with iST Control. Before installing and operating this control, carefully read and understand the contents of this manual.

For additional information, refer to the following applicable service information bulletins:

- S275-10-1 Type CI Three-Phase Fault Interrupters Installation and Operation Instructions
- MN285006EN Type VFI, Fluid Insulated, Vacuum Fault Interrupter; Installation, Operation, and Maintenance Instructions

Read this manual first

Read and understand the contents of this manual and follow all locally approved procedures and safety practices before installing or operating this equipment.

Additional information

These instructions cannot cover all details or variations in the equipment, procedures, or process described, nor provide directions for meeting every possible contingency during installation, operation, or maintenance. For additional information, please contact your Eaton representative.

Acceptance and initial inspection

The PST switchgear is completely assembled, tested, and inspected at the factory. The switchgear is filled to the correct level with insulating fluid. It is in good condition when accepted by the freight carrier for shipment.

1. Upon receipt, inspect the unit thoroughly for damage and loss of parts or fluid incurred during shipment. If damage or loss is discovered, file a claim with the carrier immediately.
2. Check for fluid leakage.

Handling and storage

The switchgear should remain on its shipping pallet until it is installed. When handling the switchgear, always use a fork truck that has adequate lifting capacity and forks that extend the entire length of the pallet. Improper handling can cause damage to the switchgear.

If the switchgear is to be stored for any appreciable time before installation, provide a clean, dry storage area. Be careful during handling and storage to minimize the possibility of mechanical damage. Do not stack other material on the switchgear.

Standards

PST Model-9 Underground Distribution Switchgear products are designed and tested in accordance with standards: IEEE Std C57.12.28™-2005 and IEEE Std 386™-2006.

Quality standards

ISO 9001 Certified Quality Management System.

PST Model-9 overall description

Type PST Model-9 Automatic Source Transfer Switchgear provides both loss-of-source health and overcurrent protection for critical loads for 15, 25, and 35 kV underground systems.

PST Model-9 units are self-contained, steel constructed underground distribution enclosures containing mineral oil or Envirotemp™ 200™ as a dielectric insulating medium. They are shipped fully assembled and filled with insulating fluid. PST Model-9 switchgear is designed for outdoor mounting on a concrete pad. Power is fed to, and from, the switchgear from underground through openings in the pad. Deadfront construction minimizes the high voltage safety hazards for both the operator and the general public.

Loss-of-source health protection functionality is provided by an iST control system and two three-phase Type CI motor-operated, source-side vacuum interrupter switches (**Figure 1**).

Eaton's Cooper Power series iST control monitors the preferred and alternate line voltages and provides the timing and control logic required to perform the automatic load transfer in the event of a source health loss. The control commands the operations of the two Type CI vacuum interrupter switches during auto transfer. Manually operated levers enable manual trip and close of source-side CI interrupter switches during power outages. Operational power (120 Vac) for the transfer control and vacuum switches is derived from system line levels via internally mounted potential transformers; no external source of power is required.

Eaton's Cooper Power series VFI Interrupters and iST control provide independent overcurrent protection of the two PST taps. Both taps are independently served by separate controls commanding the operations of a dedicated VFI vacuum fault interrupter on each tap (**Figure 1**).

Type PST Model-9 Automatic Source Transfer Switchgear with iST Control

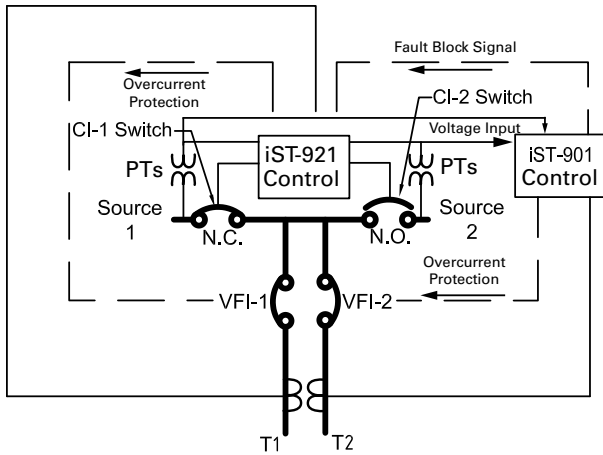

Figure 1. PST Model-9 functional diagram

Overcurrent sensing, timing, and tripping functions are performed by the iST control system. Sensing CTs, mounted internally on each phase of the tap connections, are used by the iST control system to monitor load current. If the current monitored is greater than the phase or ground minimum trip level, the control begins a user selected time-current curve (TCC) delay sequence. At the completion of the programmed TCC delay, a signal is issued to trip the VFI on the respective load tap.

Vacuum interrupters

Load-break switching and fault interruption takes place within sealed vacuum interrupters. Vacuum interrupters provide fast, low energy arc interruption and produce no arcing by-products to contaminate the insulating fluid. Use of vacuum interruption significantly reduces the maintenance required of this equipment.



Figure 2. Vacuum interrupter assembly

Bushings

Bushings are mounted horizontally in-line and located a minimum of 24 inches above the pad.

Depending on the rating of the PST Model-9 unit, bushings may be furnished in different configurations and ratings. 200 A interfaces are provided as either 200 A bushing wells or 200 A one-piece loadbreak bushings. 600 A deadbreak aluminum type bushings are furnished for PST Model-9 units rated for 600 A continuous current operation. All bushings conform to IEEE Std 386™-2006.

Standard cabinet features

Standard features (Figure 3 and Figure 4) include a fluid level indicator on each front plate, automatic pressure-relief valve, operation one-line diagrams on the doors, fluid fill plug, fluid drain and sampler, and a standoff bracket for each bushing. Standard grounding provisions include a 1/2-13 UNC stainless steel ground nut for each bushing.

Cabinet padlocking provisions

Provisions are included for padlocking the cabinet in order to prevent unauthorized door opening. The cabinet must be locked at all times to prevent accidental contact with hazardous voltage.

Cabinet construction

Type PST Model-9 switchgear features deadfront, tamper-resistant, low-profile construction. It is suitable for operation in demanding indoor and outdoor applications. Cabinets meet the enclosure security requirements of IEEE Std C57.12.28™-2005 standard.

Tank construction is of 7- or 10-gauge steel, and cabinets are made of 12- or 13-gauge steel. Recessed lifting provisions are provided at each corner of the tank for a balanced lift.

Side-hinged, cabinet style doors are provided with door stays and fitted with stainless steel hinges. Both source and tap doors can be fully open at the same time. Each door has a floating lock pocket with padlock provisions and pent-head silicon bronze door bolt.

Cabinet finish

PST Model-9 switchgear is finished in a green color, which conforms to Munsell 7GY 3.29/1.5 Green.

The coating conforms to the following specifications: IEEE Std C57.12.28™-2005, ASTM B117 24-hour 5% salt spray corrosion test, ASTM D2247 1000-hour humidity test, ASTM G53 500-hour ultraviolet accelerated weathering test, and ASTM D2794 impact test.

Type PST Model-9 Automatic Source Transfer Switchgear with iST Control

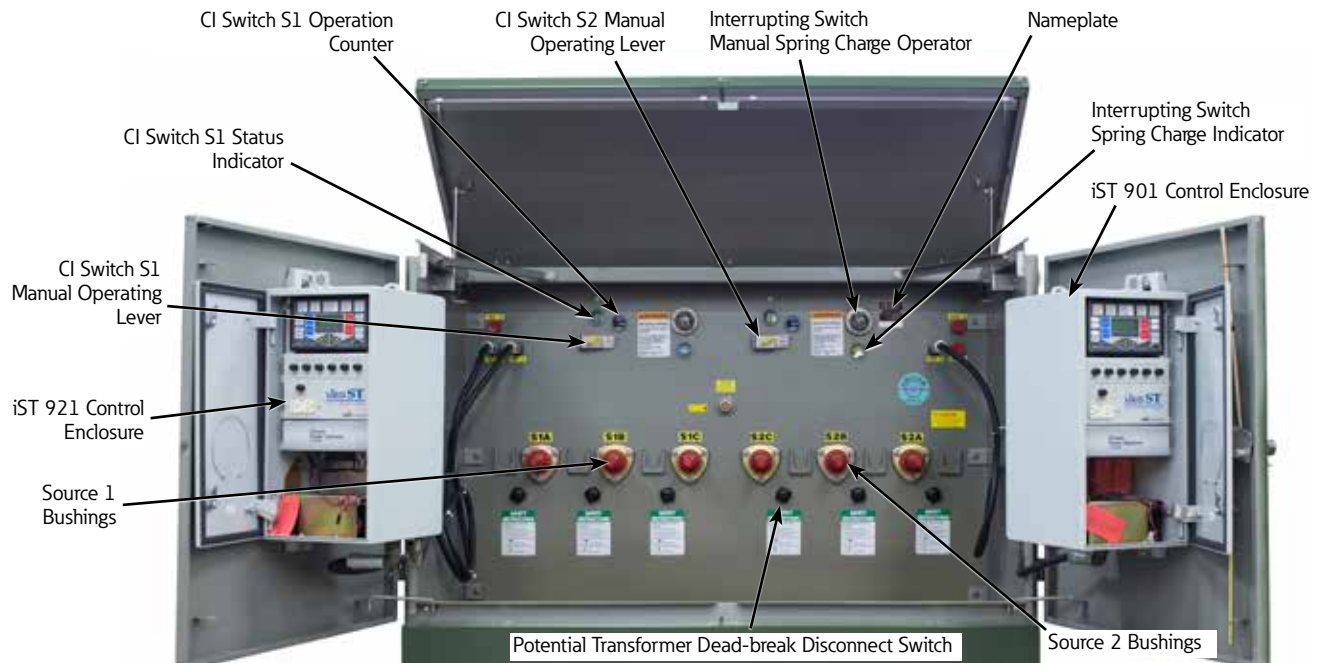

Figure 3. PST Model-9 source-side features

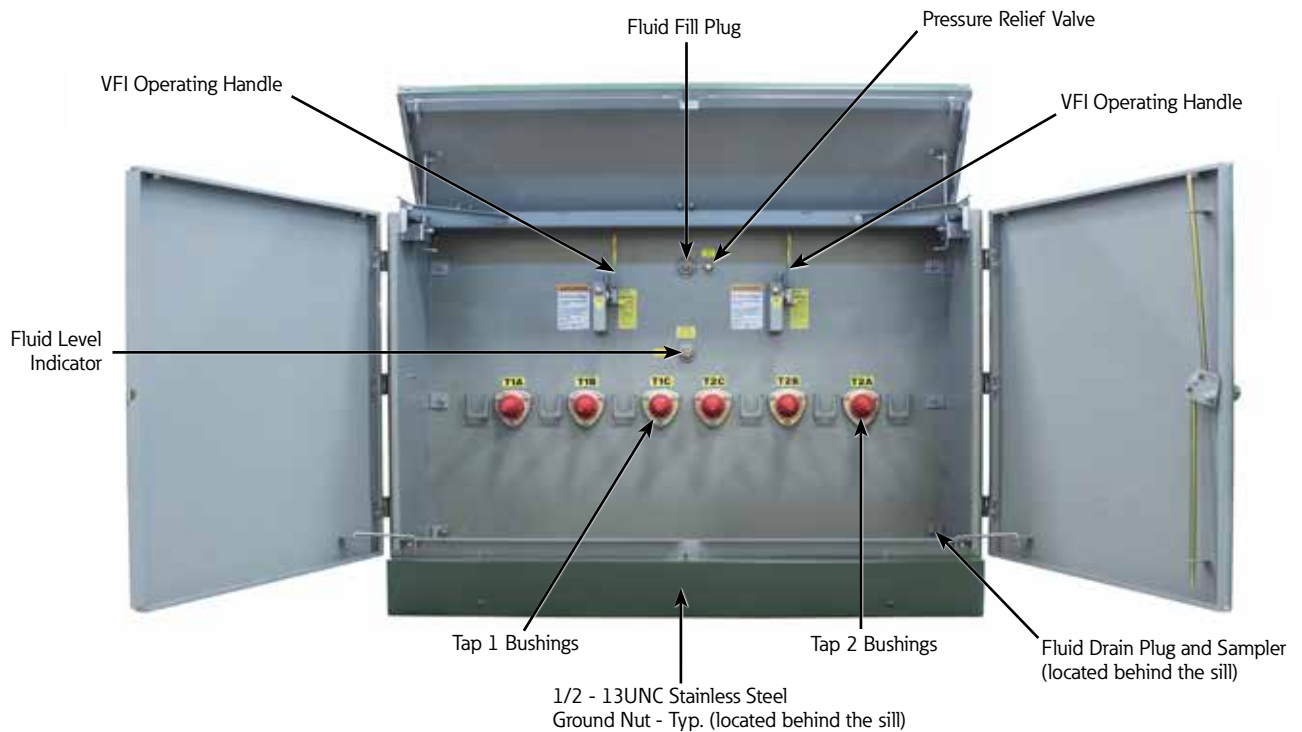

Figure 4. PST Model-9 tap-side features

Type PST Model-9 Automatic Source Transfer Switchgear with iST Control

Interrupter duty cycle

The VFI mechanism conforms to the duty cycle requirements of IEEE Std C37.60™-2003 standard.

Switch test sequence

The VFI operating mechanism conforms to the switch test sequence requirements of IEEE Std C37.60™-2003.

Nameplate

Prior to installation, check the nameplate ratings. Verify the overall current and voltage ratings, transformer ratings, and one-line diagrams are correct for the planned installation.

Operating handles

WARNING

Hazardous voltage. Never rely on the open position of the operating handle or the contact position indicator; it does not ensure that the line is de-energized. Follow all locally approved safety practices. Failure to comply can result in contact with high voltage, which will cause death or severe personal injury.

G123.1

Type PST Model-9 switchgear is equipped with hotstick-operable loadbreak switch handles for operation of the CI source-side and VFI tap-side switches.

The operating handles of CI switches provide incremental travel between the trip, close, and reset positions of the switch (**Figure 5**). CI trip-reset levers may be padlocked in the tripped position.

The Type VFI interrupters are equipped with hotstick-operable handles that are located on the tap-side of the unit. VFI operating handles are factory configured for ganged three-phase operation (all three phases operated simultaneously with a single handle). The operating handle (**Figure 6**) provides convenient push-to-close and pull-to-open operation. VFI operating handles may be padlocked in the open position.

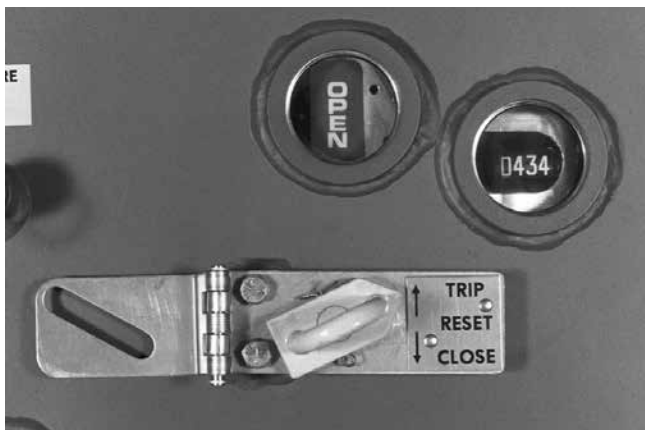

Figure 5. CI switch trip-reset lever



Figure 6. VFI operating handle, three-phase ganged operation

Weight

The weight of the switchgear is shown on the nameplate. Make sure that lifting equipment used is rated sufficiently to safely handle the switchgear.

Ratings and specifications

Table 1. Electrical ratings PST Model-9 transfer switchgear

Description	15 kV	25 kV	35 kV
Maximum Design Voltage, kV	15.5	27	38
BIL, kV	95	125	150
1-Minute Withstand Voltage (60 Hz) Interrupter and Terminators, kV	35	40	50
Continuous Current (max), A	600	600	600
Interrupting Current (sym./asym.), kA	12/20	12/20	12/20
Momentary Current 10 cycles (asym.), kA	20	20	25
1-Second Withstand Current (sym.), kA	12	12	12
Making Current (sym.), kA	12	12	12
Transformer Magnetizing Interrupting Current, A	21	21	21
Cable Charging Interrupting Current, A	10	25	40

Table 2. Interrupting duty cycle

Percent of Interrupting Current Rating	Number of Operations
15 – 20	88
45 – 55	112
90 – 100	32
Total	232

Table 3. Switching and transfer times

Direction of Transfer Transition	Type of Return (Cycles)	First Interrupter Reaction Time* Cycles	Transition Time** Cycles
Preferred to Alternate	Non-Parallel	2.0 to 3.0	5.0 to 6.0
Alternate to Preferred	Non-Parallel	2.0 to 3.0	5.0 to 6.0
Alternate to Preferred	Parallel	5.0 to 6.0	2.0 to 3.0

* Time from expiration of time delay to first opening (or closing) of high-voltage interrupter. Add about 1 cycle to values shown to allow for iST control relay time.

** Time load tap is disconnected or parallel, dependant upon transition used.

Table 4. Overall dimensions

Unit Description		Dimensions (in)			
Overall rating	Bushing Rating Source/Tap	A	B	C	D
15/25 kV	600 A/200 A	95	70	36	16
	600 A/600 A	101	70	36	22
	200 A/200 A	89	70	30	16
35 kV	600 A/200 A	103	70	40	20
	600 A/600 A	109	70	40	26
	200 A/200 A	97	70	34	20

Note: Dimensional information is for reference only, actual dimensions may vary depending on features included.

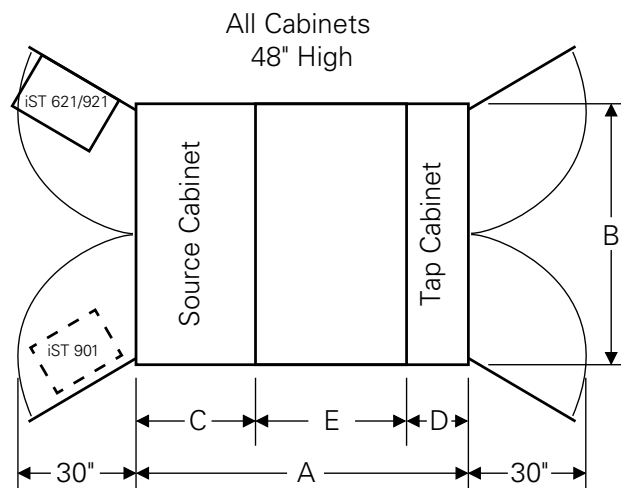

Figure 7. Cabinet dimensions

Load transfer functionality

iST control operation

The iST control monitors the source voltage and feeder current and provides the programmable timing and control logic required to perform the automatic load transfer in the event of a loss of source health. The control commands the operations of the two Type CI source switches during auto transfer.

The source health is determined by seven independent parameters for source health. Each has a settable threshold and time delay. Any combination can be enabled to declare an unhealthy source:

Type PST Model-9 Automatic Source Transfer Switchgear with iST Control

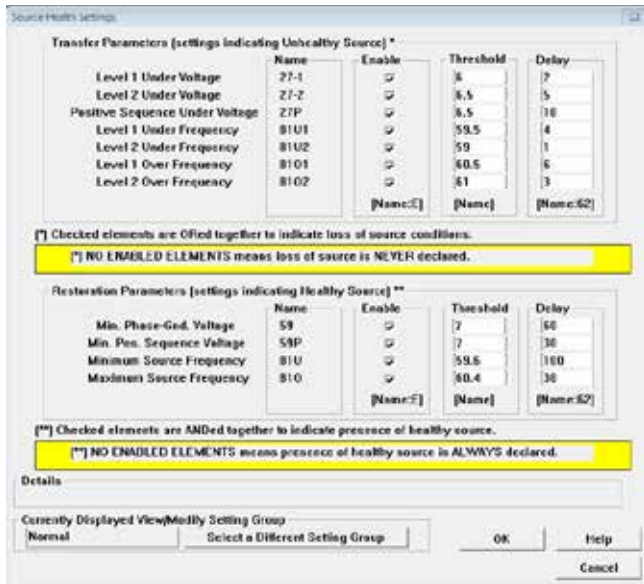

Figure 8. Source health menu

- Two levels of phase-ground undervoltage (27)
- Positive sequence undervoltage (27P)
- Two levels of underfrequency (81U)
- Two levels of overfrequency (81O)

Four independent parameters declare Source Restoration. Any combination can be enabled to declare a restored source:

- Minimum phase-ground voltage (59)
- Minimum positive sequence voltage (59P)
- Minimum frequency (81U)
- Maximum frequency (81O)

The face of the control (**Figure 12**) provides visual indication of the status of each CI switch, control settings, and manual operation capabilities. The transfer operation is programmed on the control panel; digital timer settings and switch settings permit complete program flexibility to coordinate with other system operating parameters.

The control requires 120 Vac, 50/60 Hz, 500 VA to operate the transfer switches. Quiescent power dissipation at 120 Vac is 18 watts. No external source of power is required for the control as the 120 Vac power requirement is supplied by the B-Phase (Source I) and Y-Phase (Source II) inputs from the internally mounted potential transformers.

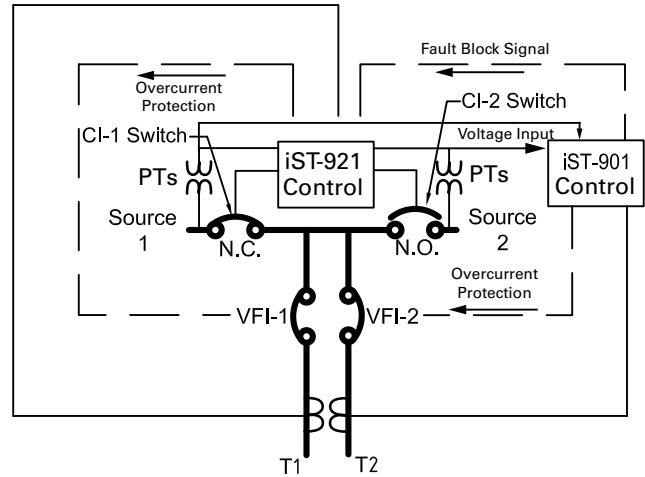

Sequence 1: Model-9 unit connected to preferred source during normal operating conditions

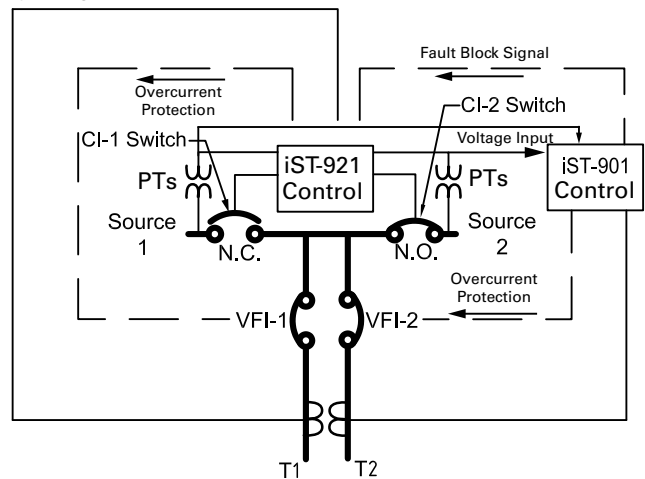

Sequence 2: Model-9 unit switched to alternate voltage source after loss of preferred voltage source

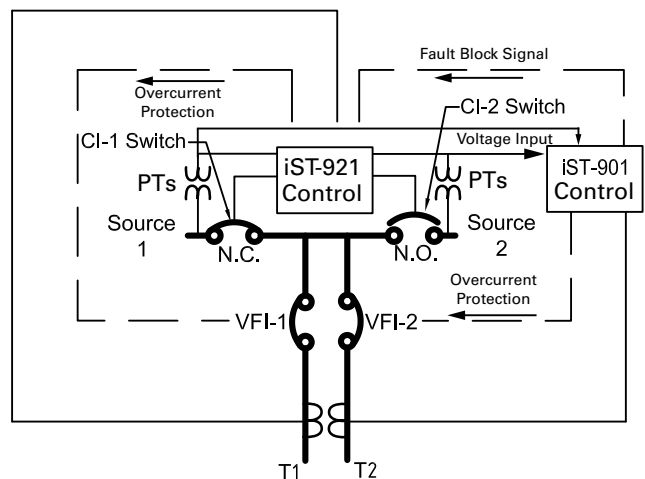

Sequence 3: Model-9 unit switched back to preferred source after restoration of preferred voltage source

Figure 9. PST Model-9 load transfer functionality

Preferred mode operation

The following is a typical **Preferred Mode** automatic load-transfer sequence (**Figure 8**):

The load is transferred to the alternate source, after completing a preset time delay, when one or more of the health parameters of the preferred source falls outside of the programmed settings and the alternate source is of good health.

The load is then transferred back to the preferred source, after completing a preset time delay, when the preferred source again becomes healthy. The return transfer can be either non-parallel (**NP**) in which the alternate-source switch opens before the preferred-source switch closes, or parallel (P) in which the preferred-source switch closes before the alternate-switch opens. With parallel return, the second outage is eliminated; however, the Sync Check function on the ProView Sync Check Tab (see **Figure 9**) is enabled to ensure both sources are in phase. The return transfer mode is selected by setting the Source Preference on, **Figure 10**.

NOTICE

Equipment misoperation. Source I and Source II high voltage switches can be paralleled by manual operation of the handles on the switch front plate, regardless of the Source Preference and Transfer Settings in the relay control. Make sure both sources are in synchronism if a manual parallel operation is to be performed. Failure to comply can result in misoperation (unintended operation) and equipment damage.

T382.0

Either Source I or Source II can be selected as the preferred (**PREF 1 or PREF II**) source by setting the Source Preference-and-Return Mode. Reference **Figure 11**.

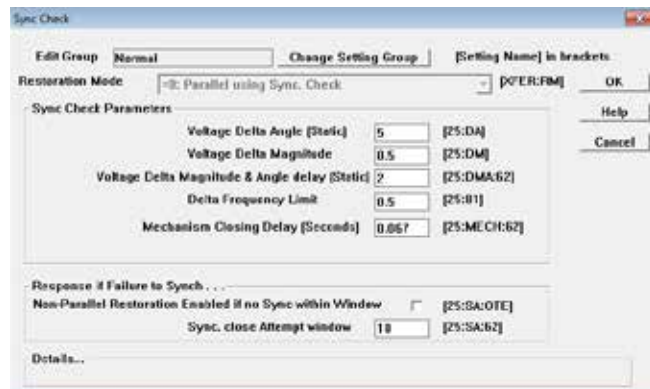

Figure 10. Sync check menu

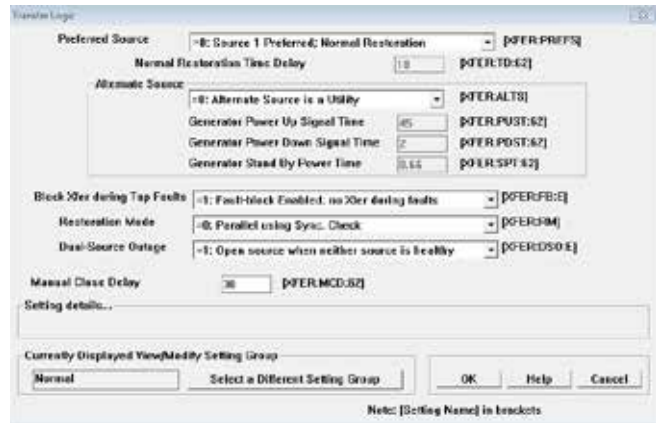

Figure 11. Source preference menu

No preference operation

When either source is acceptable for continuous critical load supply, see **Figure 11**. Upon loss of source health on Source I and after a preset time delay, the load is automatically transferred to Source II if normal voltage is present on Source II. However, the load is not transferred back when Source I voltage is restored, but remains on Source II indefinitely, until a loss of source health on Source II initiates an automatic transfer to Source I.

Hold on alternate operation

For some loss-of-voltage protection schemes, it may be preferable to inhibit return to the preferred source from the alternate source upon restoration of the preferred source voltage. By placing Control Mode into the **HOLD ON ALTERNATE** position, manual operation of the switches is required to transfer back to the preferred source. Moving Control Mode to the **NORMAL** position during return sequence inhibition will cause immediate return to the Preferred Source.

Type PST Model-9 Automatic Source Transfer Switchgear with iST Control

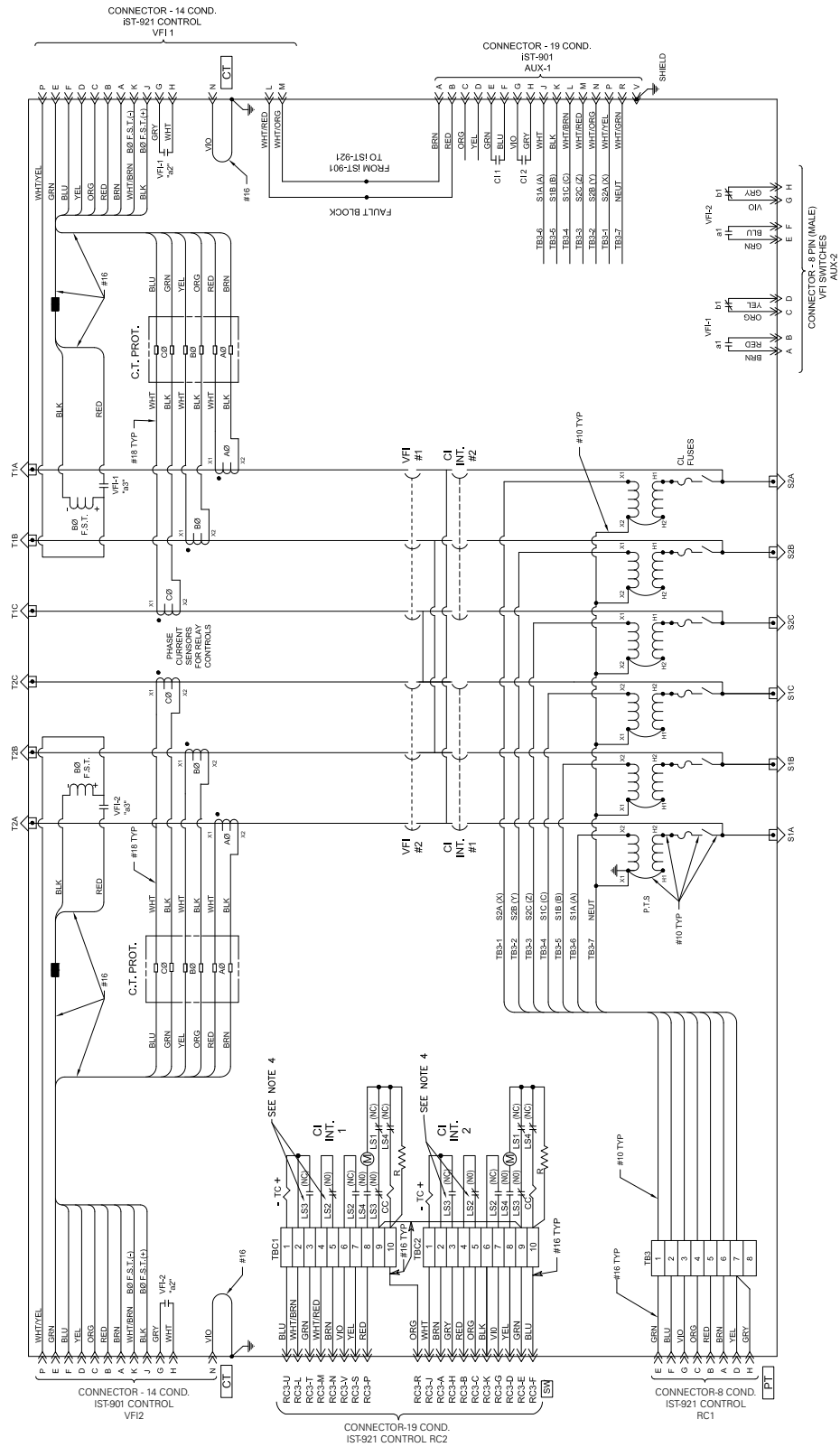

Figure 12. PST Model-9 automatic source transfer switchgear schematic

Type PST Model-9 Automatic Source Transfer Switchgear with iST Control

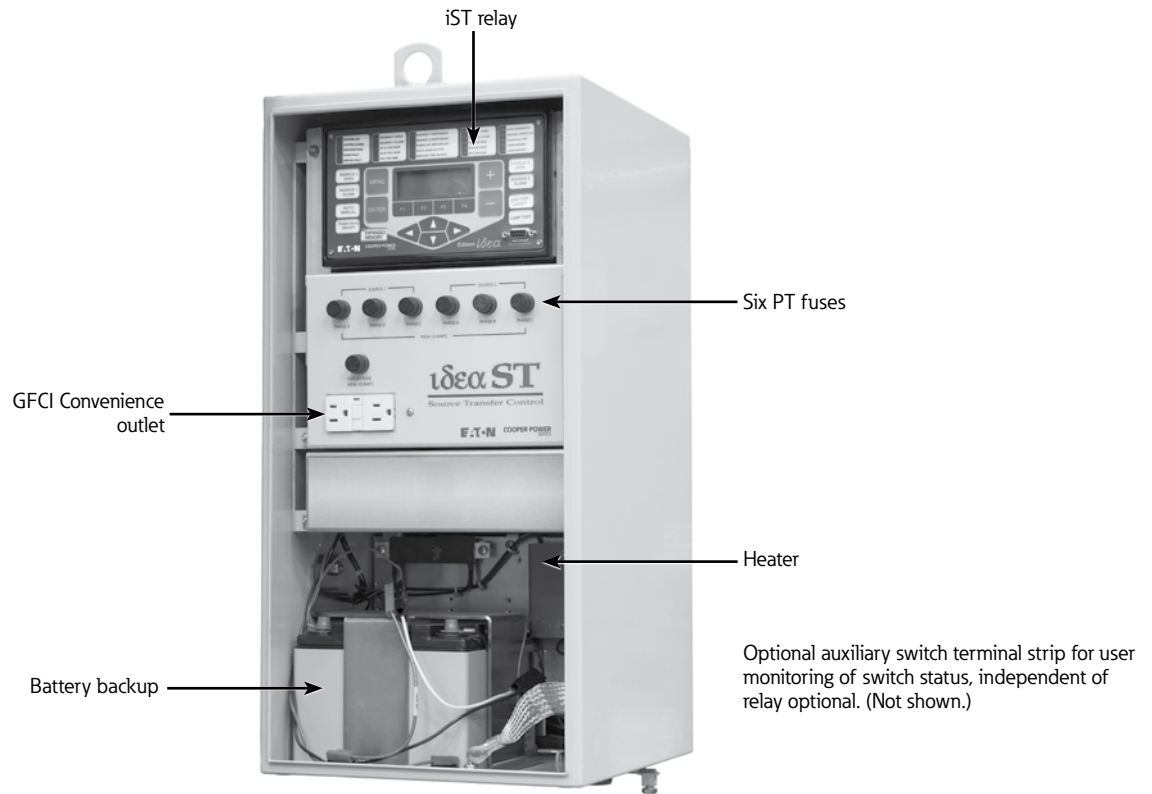

Figure 13. iST control

Manual operation

Each switch can be independently opened and closed manually by setting Operation Selector to **MANUAL** and operating MANUAL OPER. SOURCE S1 and MANUAL OPER. SOURCE S2 as required.

NOTICE

Parallel connection of sources is possible when manually closing CI interrupters. If parallel connection of sources is not desired, do not operate the trip-reset levers of both CI interrupters into the closed position.

T275.0

IMPORTANT

If Control Mode is placed in "AUTO" mode, the iST control will place the high-voltage Type CI transfer switches into the configuration that is currently selected by the Source Preference. This may result in an unintended transfer. Make sure the desired state of the high-voltage Type CI transfer switches match the setting of Source Preference before returning Control Mode to "AUTO" mode.

Operation of interval timer

IMPORTANT

Put control in manual mode prior to changing timer setting. There is no loss of voltage protection when in manual mode. Failure to comply can cause unintended operation.

The iST control features multiple digital timers with automatic reset. Each of the seven available source health parameters has a user programmable time delay setting from 0-3600 seconds. When returning from alternate, each of the (four) 4 restoration parameters has a user programmable time delay setting from 30-3600 seconds.

The time-delay setting for preferred-to-alternate-source transfer must be long enough to allow discrimination between permanent loss of voltage and temporary loss of voltage due to transient effects or reclosing intervals of backup protective reclosers or breakers.

The time delay for return from alternate to preferred source upon restoration of preferred-source voltage should be set for an interval long enough to assure that service on the preferred source has been permanently restored.

Type PST Model-9 Automatic Source Transfer Switchgear with iST Control

When the iST control is programmed to operate in the no-preference mode, there are no preferred or alternate sources. Time-delay intervals for transfer from Source I to Source II are governed by the left preferred-to-alternate timer and for transfer from Source II to Source I by the right alternate-to-preferred timer.

CI switch

Eaton's Cooper Power series Type CI three-phase motor-operated source transfer switches (**Figure 14**) employ long-life vacuum interrupters. The vacuum interrupter contacts are opened and closed by a mechanism that releases stored spring energy. The separate opening and closing springs are automatically charged by a 120 Vac motor. The load transfer interrupter switches are electrically operated and receive trip or close signals from the iST control. Solenoids receive the command signals and release the charged springs to effect a quick close operation of the vacuum contacts, and Flux-Shift Trippers (FST) receive the command to release the charged springs to effect a quick open operation.

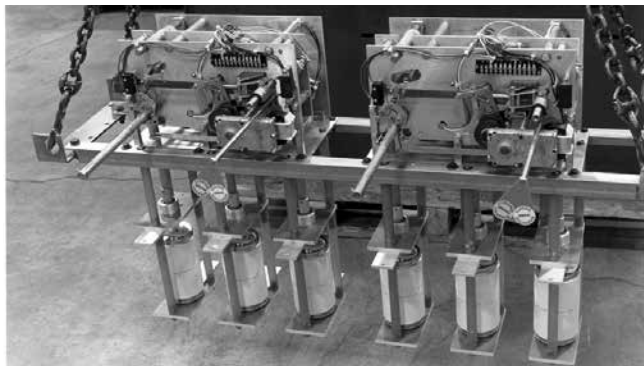

Figure 14. CI switches

CI switches can be manually operated for test purposes or if operating power is lost. A hotstick operable, external trip-reset lever (**Figure 15**) allows switches to be opened and closed manually. An external push-pull operator is provided for manually charging the springs (**Figure 16**). The push-pull operator is easily operated with a hotstick.



Figure 15. CI switch trip-reset lever



Figure 16. Manual push-pull spring charging operator

Operating modes

The CI switches can be tripped automatically, electrically, or manually operated; they can be closed electrically or manually provided the springs are charged. CI switch operating modes are:

Automatic

The CI Switch Trip-Reset Levers (S1 and S2) must be in the RESET position for automatic load transfer control operation to occur. Tripping and closing of the CI transfer switches is initiated by a signal from the iST control. An opening signal briefly energizes the opening FST and releases a latch that trips the opening springs. A closing signal energizes the closing solenoid and trips the closing spring. Closing is not permitted until the limit switch closes to indicate that the springs are charged.

Electrical

Non-automated opening and closing are initiated by operation of the membrane pushbutton (**Figure 26**) on the iST control front panel. Non-automated electrical opening and closing is permitted only when the iST control is operating in the manual mode.

Manual

Tripping and closing are initiated by operation of the manual trip-reset handles located on the source-side pad-mounted tank.

CI operating sequences

When the interrupter contacts are open and the 120 Vac supply to the spring charging motor is energized, the spring charging motor will charge the closing and opening springs. The CI Trip-Reset Levers (S1 and S2) must be in the RESET position for this operation to occur. Upon receipt of a closing signal, a solenoid-operated latch releases the closing spring which drives the three vacuum interrupter contacts to their closed position.

As the contacts are closed, the closing spring energy is discharged while the opening spring remains charged and latched. Upon receipt of an opening signal, the FST releases the opening-spring latch, and the contacts of all three vacuum interrupters are simultaneously driven to their open position as the opening spring discharges. Immediately after the contacts reach full open, the spring charging cycle is repeated as the spring charging motor runs to recharge the springs. Recharging is completed in about 20 seconds, and both closing and opening springs are then latched and ready for future operations. Should the 120 V motor power be lost while the interrupter contacts are open but after the springs have been charged, one contact closing operation can still be achieved through use of the trip-close handle on the mechanism tank. Likewise, after the interrupter has been closed, energy for one trip operation remains stored in the mechanism.

Manual operation of CI switches

With its manual spring-charging capability, the CI switches can be operated without the presence of the low-voltage motor supply from the iST control.

DANGER

Hazardous voltage. Contact with hazardous voltage will cause death or severe personal injury. Follow all locally approved safety procedures when working around high- and low-voltage lines and equipment.

G103.3

WARNING

Hazardous voltage. Never rely on the open position of the operating handle or the contact position indicator; it does not ensure that the line is de-energized. Follow all locally approved safety practices. Failure to comply can result in contact with high voltage, which will cause death or severe personal injury.

G123.1

NOTICE

Equipment misoperation. Source I and Source II high voltage switches can be paralleled by manual operation of the handles on the switch front plate, regardless of the Source Preference and Transfer Settings in the relay control. Make sure both sources are in synchronism if a manual parallel operation is to be performed. Failure to comply can result in misoperation (unintended operation) and equipment damage.

T382.0

Manual closing of CI switch

NOTICE

Parallel connection of sources is possible when manually closing CI interrupters. If parallel connection of sources is not desired, do not operate the trip-reset levers of both CI interrupters into the closed position.

T275.0

Manual closing during loss of 120 Vac supply can be accomplished by using the following procedure:

1. Put the iST control system into MANUAL mode to eliminate any unexpected opening and closing of the CI source switches when Vac supply is restored.
2. Observe the CI switch spring status indicator. If the indicator shows the springs are discharged, proceed with Step 3. If the indicator shows springs are charged, proceed to Step 5.
3. Move the CI Transfer Switch Trip-Reset lever to the TRIP position and then to the RESET position.
4. Using a hotstick stick, pull the spring charging handle approximately 30 times or until the spring charging indicator switches from the white, "spring discharged," to the yellow, "springs charged," position.
5. Move the Trip-Reset lever to CLOSE. Interrupter contacts will close and handle will spring back to the RESET Position.

Manual tripping of CI switch

1. Move the CI switch lever to the TRIP position. This action will release a trip in the operating mechanism that allows the charging springs to drive the contacts to their open position. The trip-reset lever will remain in the TRIP position.

The interrupter can not be closed by the iST control while the Trip-Reset Lever is in the TRIP position.

For additional information regarding the operation and adjustment of Type CI Vacuum Interrupters Switches, refer to *Service Information Bulletin S275-10-1, Type CI Three-Phase Fault Interrupters Installation and Operation Instructions*.

Overcurrent protection functionality

For dual feeder applications, the iST-921 relay provides overcurrent protection for feeder 1, and the iST-901 relay provides overcurrent protection for feeder 2. A Fault-block function is included to enable or disable automatic transfer during the overcurrent (OC) event.

When enabled in the iST-921/iST-901 two feeder application, fault block prevents an automatic transfer while either OC element is picked up. When the OC element drops out after a trip, automatic operations resume for the feeder that remains in service.

Type PST Model-9 Automatic Source Transfer Switchgear with iST Control

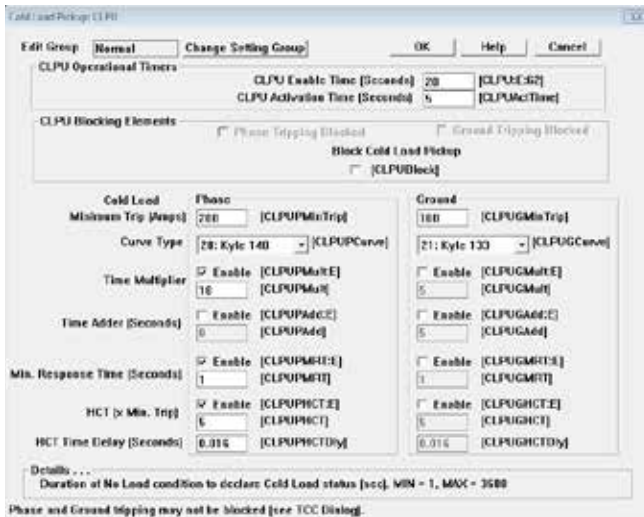

Figure 17. Cold load pickup (CLPU) menu

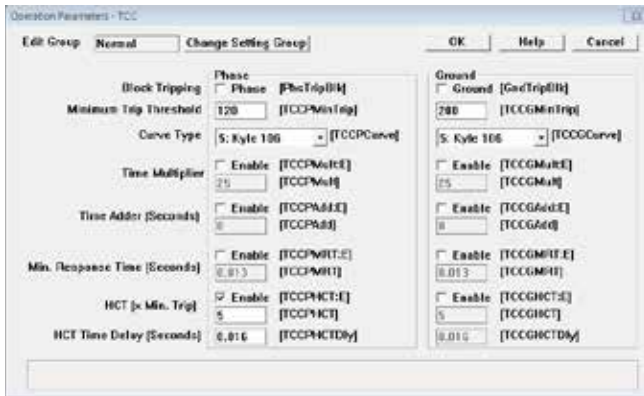

Figure 18. Time-current curve (TCC) menu

Vacuum fault interrupters (VFI)

Eaton's Cooper Power series vacuum fault interrupters (VFI) provide fault current interruption and load make/break switching capabilities. Hotstick-operable operating handles are located on the front plate of the unit. Standard VFI operating mechanisms are factory configured for ganged 3 phase operation.

Current sensing transformers, located inside the switchgear tank, provide line current information to the iST control system. When line current exceeds the minimum trip setting, the control initiates a signal that causes the VFI to interrupt the circuit. Interruption may be single- or three-phase depending upon the configuration of the control and VFI.

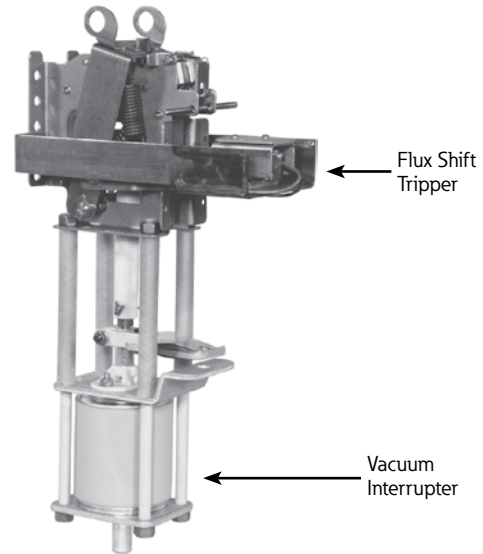

Figure 19. Vacuum interrupter assembly

Manual VFI operation

⚠ DANGER

Hazardous voltage. Contact with hazardous voltage will cause death or severe personal injury. Follow all locally approved safety procedures when working around high- and low-voltage lines and equipment. G103.3

⚠ WARNING

Hazardous voltage. Never rely on the open position of the operating handle or the contact position indicator; it does not ensure that the line is de-energized. Follow all locally approved safety practices. Failure to comply can result in contact with high voltage, which will cause death or severe personal injury. G123.1

⚠ WARNING

Do not operate this equipment if energized parts are not immersed in dielectric fluid. Operation when parts are not properly immersed in dielectric fluid may result in internal flashovers that will damage the equipment and can cause death or severe personal injury. G104.4

⚠ WARNING

Hazardous voltage. Always use a hotstick when working with this equipment. Failure to do so could result in contact with high voltage, which will cause death or severe personal injury. G108A.0

The VFI operating handles (Figure 4 and Figure 19) are located on the tap-side front plate of the PST Model-9 unit. The VFI operating handles must be operated with a hotstick.

Opening VFI switches

The Vacuum Fault Interrupter (VFI) is opened by pulling the operation handle down to the open position. The handle may be padlocked in the open position to prevent accidental closure.



Figure 20. VFI operating handle, three-phase ganged operation

Resetting VFI switches

After the VFI mechanism has tripped as the result of a fault condition, the mechanism must be reset before it can be closed. To reset the mechanism, firmly pull the operating handle down toward the ground until the latch resets. After the latch has been successfully reset, the VFI mechanism can be closed normally.

Closing VFI switches

The Vacuum Fault Interrupter (VFI) is closed by briskly pushing the handle up into the closed position.

For additional information regarding the operation of Vacuum Fault Interrupters, refer to: *Service Information Bulletin MN285006EN, Type VFI, Fluid-Insulated Switchgear; Installation, Operation, and Maintenance Instructions.*

Installation procedures

WARNING

This equipment is not intended to protect human life. Follow all locally approved procedures and safety practices when installing or operating this equipment. Failure to comply can result in death, severe personal injury, and equipment damage.

G102.1

1. Check fluid level. Make sure the fluid in switchgear tank is at the proper level by checking the fluid level indicator on the source-side and tap-side panels; both indicators should be at the proper level.

2. Test fluid dielectric strength and moisture content. If the switchgear has been stored for some time or is being relocated, perform a dielectric test and moisture analysis on the fluid in accordance with ASTM-approved testing procedures.

WARNING

This equipment relies on dielectric fluid to provide electrical insulation between components. The dielectric strength and moisture content of the fluid must be checked on a regular basis, as part of the routine maintenance inspection, to ensure that it is at or above minimum dielectric requirements and below the maximum moisture content. Use of this equipment with dielectric fluid that does not meet requirements can result in internal flashovers that will damage the equipment and can result in death or serious injury. G107.3

- a. In new equipment, the fluid must have a minimum dielectric strength of 26 kV. If the dielectric strength of the fluid is less than 26 kV, process or replace the fluid to restore its dielectric strength to the acceptable minimum level.
 - b. For additional information on fluid specifications and tests, refer to *Reference Data TD280022EN* and to the **Fluid testing** section of this manual.
3. Check the nameplate ratings. Verify the overall current and voltage ratings, transformer ratings and one-line diagrams are correct for the planned installation.

WARNING

Falling equipment. Use the lifting lugs provided and follow all locally approved safety practices when lifting and mounting the equipment. Lift the unit smoothly and do not allow the unit to shift. Improper lifting can result in severe personal injury, death, and/or equipment damage.

G106.3

NOTICE

Equipment damage. Never place jacks, tackle or other attachments under the unit for the purpose of lifting. Failure to comply will result in damage to the equipment.

T240.0

NOTICE

Equipment damage. Improper lifting may cause equipment damage and may lead to premature failure. Recommend lifting with full length spreader beam. T375.0

4. Mount switchgear on concrete pad.
 - a. The switchgear must be installed on a level concrete pad or structure that has been designed to support the size and weight of the unit.
 - b. The switchgear must be hoisted only by the recessed lifting provisions provided at the four corners of the tank. Suitable lifting straps and a

Type PST Model-9 Automatic Source Transfer Switchgear with iST Control

spreader bar of adequate capacity must be used to prevent damaging the switchgear housing. The use of chains is not recommended as it may damage the cover and associated gasket seal.

5. Ground switchgear. Switchgear must be adequately grounded. Make a permanent, low-resistance, ground connection at the 1/2-13 UNC connectors located at the bottom of the switchgear front plates (refer to **Figure 4**). The iST control system is grounded to the source-side front plate of the switchgear tank with a woven grounding cable.

⚠ WARNING

Hazardous voltage. Solidly ground all equipment. Failure to comply can result in death, severe personal injury, and equipment damage.

T223.2

6. Make high-voltage line connections.
 - a. Prior to making connections, verify the source-side and tap-side connectors are correctly identified. Verify the PST Model-9 unit is oriented correctly for the installation; the source leads must connect to the source bushings, and tap leads must connect to the tap bushings of the unit.
 - b. Refer to the operation one-line diagram located inside the doors of the switchgear, and make only those connections shown. The voltage and current ratings shown on the nameplate must be correct for the planned installation.
 - c. All cables or bushings not in use must be properly isolated. Unused leads must be properly terminated and parked on standoff insulators or properly grounded.
 - d. All bushings not in use must be insulated with a properly rated isolation cap. It is also recommended that bushing elbow studs be pre-installed for future use. The studs must be torqued into place, and this must be done before the equipment is energized.

IMPORTANT

Do not use the red shipping covers on unused bushings. They are not designed for permanent use on energized equipment.

7. Close and lock switchgear doors. Switchgear doors must be closed and locked in order to prevent unauthorized access and accidental contact with high voltage.

⚠ DANGER

Hazardous voltage. Contact with hazardous voltage will cause death or severe personal injury. Follow all locally approved safety procedures when working around high- and low-voltage lines and equipment.

G103.3

⚠ WARNING

Hazardous voltage. Never rely on the open position of the operating handle or the contact position indicator; it does not ensure that the line is de-energized. Follow all locally approved safety practices. Failure to comply can result in contact with high voltage, which will cause death or severe personal injury.

G123.1

⚠ WARNING

Do not operate this equipment if energized parts are not immersed in dielectric fluid. Operation when parts are not properly immersed in dielectric fluid may result in internal flashovers that will damage the equipment and can cause death or severe personal injury.

G104.0

⚠ WARNING

Hazardous voltage. Always use a hotstick when working with this equipment. Failure to do so could result in contact with high voltage, which will cause death or severe personal injury.

G108A.0

Initial mechanical operation check

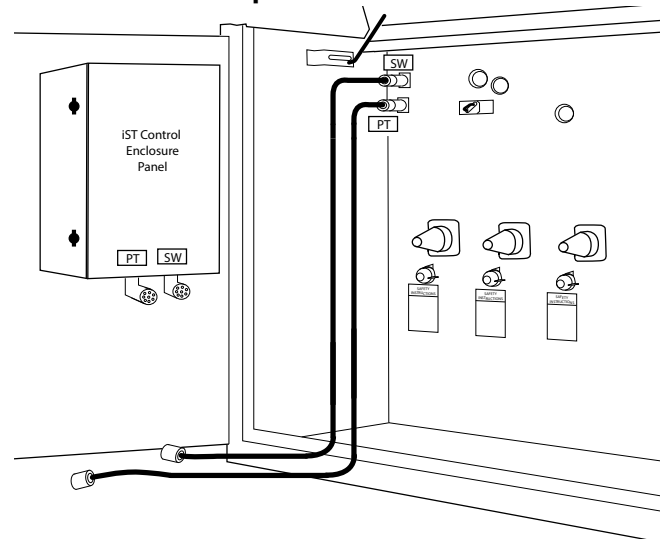

Figure 21. Disconnection of CI switch cable at SW receptacle of iST relay enclosure

Note: Shown in the above figure is the left control panel only. Both left and right control panels must be disconnected in order to be completely de-energized. Plugs are situated underneath the iST control panel and not visible as shown in the illustration.

⚠ WARNING

Hazardous voltage caused by improper disconnection. Both the right and left control panels must be disconnected. Failure to do so will result in risk of

possible contact with high voltage at the source bushings, which may cause death or severe personal injury.

T384.0

With the PST Model-9 unit out of service and de-energized, remove all control cables (See **Figure 21**) and conduct the following test:

1. Set all PT switches on the PST-9 switchgear (see **Figure 3**) to the 'OFF' position.
2. Verify CI switch springs are discharged by moving both yellow Trip-Reset levers to the CLOSE position.
3. If CI switch S1 is closed, open it by operating the yellow trip-reset lever above the S1 bushing to the TRIP position. Position indicator will show a green OPEN flag. See **Figure 14**.
4. Move the yellow trip trip-reset lever to the reset position.
5. Pull the spring charging operator handle approximately 30 times or until the spring charging indicator switches from the white, "spring discharged," to the yellow, "springs charged," position. See **Figure 19**.
6. Move the yellow trip-reset lever to the CLOSE position.



Figure 22. Push-pull charge spring operator indicator before and after manual charging of CI switch

7. Switch S1 should close with audible "thunk" and position indicator should switch to a red "closed" flag.
8. Move the yellow trip-reset lever to the TRIP position. Unit should trip open and position indicator should read open.
9. Repeat steps 2 – 6 for CI interrupter switch S2.
10. Re-connect cable between tank receptacle SW and iST control receptacle RC1.

Initial electrical operation check

With the PST Model-9 out of service and de-energized, isolate the potential transformers to eliminate risk of contact with hazardous voltage caused by transformer backfeeding during testing operations. Isolate the transformers with the following procedure.

1. At the PT receptacle of the iST control, disconnect the cable connecting to the corresponding PT receptacle located on the source-side front plate of the tank (**Figure 23**).
2. Disconnect the switchgear's internal potential transformer via the six manually operated deadbreak switches located below each source bushing (**Figure 3**).
3. Install insulating caps on all source and tap bushings.

Verify proper electrical operation using the following procedure:

1. Place the yellow CI Switch Trip-Reset levers, located on the source-side panel, into the reset position.
2. Connect 120 Vac, 60 Hz power supply to terminals B and Y of Terminal Strip TB8 of the iST control. Connect the grounded side of the power supply to terminal N (**Figure 24** and **Figure 25**).
3. Jumper terminal Z to Y to X, and C to B to A.

⚠ WARNING

Hazardous voltage caused by backfeeding of transformers. Isolate potential transformers from source bushings using potential transformer dead-break disconnect switches located on the source-side panel. Failure to do so will result in risk of possible contact with high voltage at the source bushings, which may cause death or severe personal injury.

T273.0

4. The spring charging motor of one or both CI switches, depending on whether the respective interrupter springs are charged or discharged, should begin to operate after completion of Steps 1 – 3. Motor spring charging takes approximately 30 seconds.

Type PST Model-9 Automatic Source Transfer Switchgear with iST Control

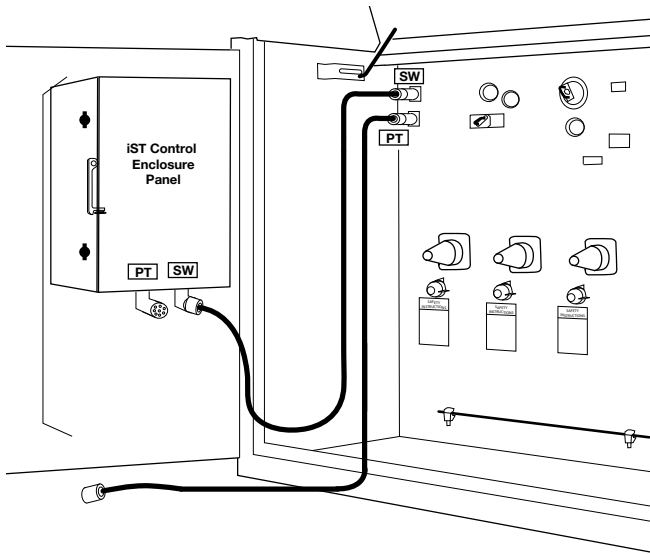

Figure 23. Disconnection of potential transformer cable at PT receptacle of iST control enclosure panel

Note: Plugs are situated underneath the iST control panel and not visible as shown in the illustration.

WARNING

Hazardous voltage caused by improper disconnection. Both the right and left control panels must be disconnected. Failure to do so will result in risk of possible contact with high voltage at the source bushings, which may cause death or severe personal injury.

T384.0

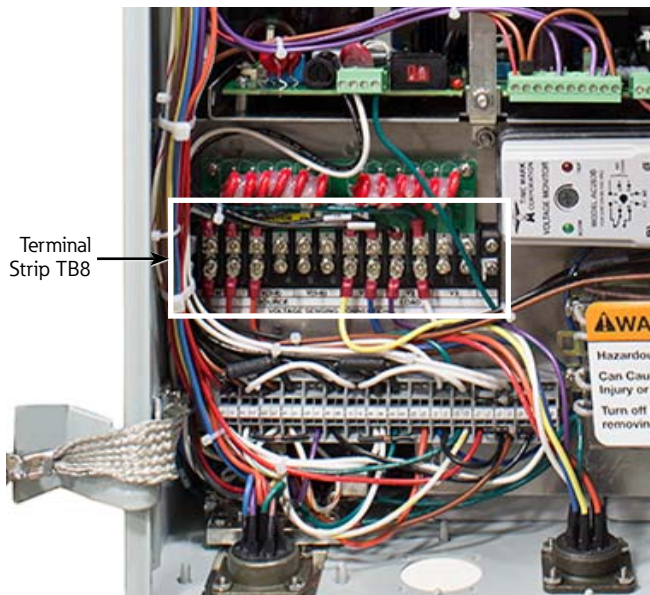

Figure 24. Location of terminal strip TB8 behind rear door of iST control

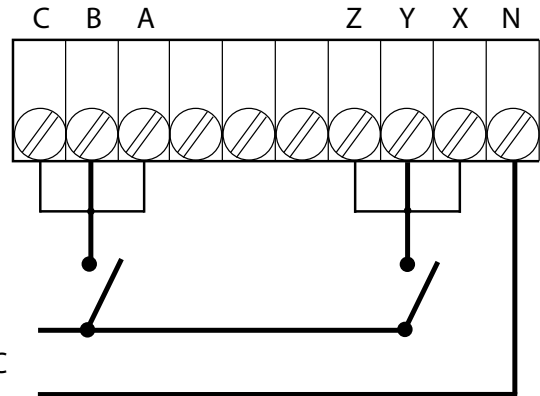

Figure 25. Connection of AC power to TB8 for initial electrical operation testing of the PST Model-9 unit

Initial iST control operation check

NOTICE

Equipment misoperation. Source I and Source II high voltage switches can be paralleled by manual operation of the handles on the switch front plate, regardless of the Source Preference and Transfer Settings in the relay control. Make sure both sources are in synchronism if a manual parallel operation is to be performed. Failure to comply can result in misoperation (unintended operation) and equipment damage.

T382.0

1. Press the AUTO/MANUAL button to place the iST control into MANUAL MODE.
 - a. Confirm by verifying red MANUAL OPERATION LED is lit.
2. Press SOURCE 1 CLOSE.
 - a. Verify Source 1 high-voltage CI transfer switch is closed.
3. Press SOURCE 1 OPEN, and verify Source 1 is open.
 - a. Verify Source 1 high-voltage CI transfer switch is open.
4. Follow steps 2 & 3 for Source 2.
5. Set SOURCE PREFERENCE MODE to desired source preference mode.
 - a. To select SOURCE PREFERENCE, press MENU on the Front Panel, and then select Settings in display by pressing ENTER. Verify that Mod/View Settings appears, and press ENTER. Enter password if required; otherwise press ENTER. Select TRANSFER LOGIC in the display by pressing the down arrow on the front panel followed by ENTER. Select XFER:PREFS, and press ENTER. Use the [+] or [-] keys to select the desired source preference.

- b. Hit MENU, and then select USE by hitting the F1 key. The controller will reboot after selecting to use.
6. Set RESTORATION MODE to the preferred restoration mode.
 - a. To select RESTORATION MODE, Press MENU on the Front Panel, and then select Settings on the display by pressing ENTER. Verify that Mod/View Settings appears, and press ENTER. Enter password if required; otherwise press ENTER. Select TRANSFER LOGIC in the display by pressing the down arrow on the front panel followed by ENTER. Scroll down to select XFER:RM, and press ENTER. Use the [+] or [-] keys to select between PARALLEL or OPEN restoration mode.
 - b. Hit MENU, and then select USE by hitting the F1 key. The controller will reboot after selecting to use.
7. With the control in MANUAL mode, manually close the selected source by pressing SOURCE 1 CLOSE or SOURCE 2 CLOSE (whichever was chosen as the preferred source from the previous step).
8. Press the AUTO/MANUAL button to switch the iST control into automatic mode, and verify the green AUTOMATIC OPERATION LED is lit.
9. To simulate loss of voltage on any phase of either source, simply remove an appropriate fuse from the front panel of the iST control, and depending on settings, wait for the timer to time out and initiate transfer to the alternate source.
10. After the transfer has successfully completed, replace the fuse pulled in Step 8, and verify that the unit correctly returns to the preferred source.



Figure 26. iST control front panel user interface

Maintenance

⚠ WARNING

This equipment relies on dielectric fluid to provide electrical insulation between components. The dielectric strength and moisture content of the fluid must be checked on a regular basis, as part of the routine maintenance inspection, to ensure that it is at or above minimum dielectric requirements and below the maximum moisture content. Use of this equipment with dielectric fluid that does not meet requirements can result in internal flashovers that will damage the equipment and can result in death or serious injury. G107.3

⚠ CAUTION

This equipment requires routine inspection and maintenance to ensure proper operation. If it is not maintained, it can fail to operate properly. Improper operation can cause equipment damage and possible personal injury. G105.1

The Type PST switchgear is a deadfront design. All live parts are contained within the sealed tank enclosure. A routine maintenance inspection program is required to ensure proper operation.

It is necessary to establish and maintain a regular schedule for sampling and testing the insulating fluid to ensure proper dielectric strength, moisture content, and fluid levels in the switchgear.

Maintenance inspection procedure

The Type PST switchgear must be de-energized, grounded, and removed from service before conducting any maintenance, fluid processing, or fluid-filling procedures.

⚠ WARNING

Hazardous voltage. This equipment must be de-energized and grounded prior to conducting any maintenance, dielectric fluid processing, or dielectric fluid filling procedures. Failure to comply can result in death or severe personal injury. T239.2

1. **De-energize and ground switchgear.**
2. **Reduce internal tank pressure to 0 PSIG.** The switchgear is equipped with a pressure relief valve that opens at 5 PSIG and closes at 3 PSIG. To relieve internal tank pressure pull the ring on the pressure relief valve.
3. **Perform the following inspections:**
 - **Check fluid level** – refer to the **Fluid fill guidelines** section of this manual if fluid levels are low.

Type PST Model-9 Automatic Source Transfer Switchgear with iST Control

Note: When the switchgear is installed on a level surface, the ball float in the fluid level indicator sight gauge on the front plate will be at the top of the site glass when fluid temperatures is 68 °F (20 °C) or higher. Colder temperatures and/or an uneven pad will result in the gauge indicating less than maximum fluid levels.

- **Inspect tank cover** – the tank cover should be free of chipped paint and corrosion. If a crack or hole is found, obtain a fluid sample and check moisture content and dielectric strength immediately. If a replacement cover or cover gasket is needed, refer to the **Replacement parts** section of this manual.
- **Inspect tank exterior for fluid leaks** – there should be no fluid staining on or near the tank seals at the bushings, visible break windows, and other gasketed seals on the front plates. If fluid stains are present, check the fluid level, and see the **Fluid fill guidelines** section of this manual if more fluid is required. Bushing leaks may be sealed by re-applying torque to the bushing clamp hardware (5 to 6 ft-lbs). Do NOT tighten visible break window hardware. First check for cracks in the window. If found order replacement window kit. If no cracks, tighten hardware (95 to 105 in-lbs).
- **Check bushing and elbow conditions** – elbow connections should be secure and free from unusual wear. Record abnormalities and contact the manufacturer with any concerns.
- **Inspect tank and cabinets for corrosion or unusual signs of wear** – contact the manufacturer with any concerns.
- **Functionality check** – verify that cabinet doors close and lock properly. Verify manual operation of each switch and VFI. Contact the manufacturer with any concerns.
- **Record any other unusual wear/abnormalities** – contact the manufacturer with any concerns.

Internal inspection and repair

If internal damage is suspected or if the switchgear must be opened for inspection, the following procedure is recommended.

WARNING

Hazardous voltage. This equipment must be de-energized and grounded prior to conducting any maintenance, dielectric fluid processing, or dielectric fluid filling procedures. Failure to comply can result in death or severe personal injury.

T239.2

1. De-energize and ground switchgear.
2. Draw a fluid sample. Use the drain plug with sampler at the bottom of the tank. If moisture is found in the tank, re-fill with clean, dry insulating fluid.

3. Clean off tank cover. Take appropriate precautions to keep dirt, moisture and other foreign matter from entering the tank and contaminating the insulating fluid.
4. Remove tank cover.
5. Inspect for internal damage. Check inside the switchgear for broken leads or loose parts. If any bushings or interrupters are damaged repair as required.
6. Bushing repairs. The bushings can be changed with the tank cover removed.
 - a. Lower the fluid level as needed to make repairs. Store the drained fluid according to locally approved procedures and in a sealed, clean, and dry container.
 - b. Disconnect the internal cables and leads.
 - c. Unbolt external steel clamps from the front plate, and replace any damaged bushings or bushing wells with new parts and a new gasket. Be sure to position gasket so it will seal properly.
7. Interrupter repairs. Contact your local Eaton's Cooper Power Systems sales representative for additional information and ordering procedures.
8. Replace tank cover. New gaskets should be used when re-installing the cover. Refer to the **Replacement parts** section of this manual for further instructions.
9. Re-fill with insulating fluid. Refer to the **Fluid sampling guidelines** section in this manual, and make sure that the unit is properly filled to the 68 °F (20 °C) fluid fill level with clean, dry insulating fluid.
10. Close and lock doors. After repairs are completed, close and lock switchgear doors in order to prevent unauthorized access and accidental contact with high voltage lines.

Insulating fluid maintenance

To assure trouble-free operation of this equipment, a regular schedule of fluid testing and fluid maintenance is required. A routine fluid testing and maintenance schedule is necessary to monitor changes that occur in the fluid as a result of normal operation and to detect abnormal conditions that may occur.

Maintaining a record of this test data will help in assessing the condition of the fluid over time.

Frequency of maintenance

The insulating fluid should be initially tested within two years after the installation of the equipment. That test will yield information required to establish a baseline reference for observing trends in the unit's normal operation and to diagnose any fault conditions that may be present.

After the initial oil testing and inspection, vacuum switchgear should be maintained every two years.

Each scheduled pad-mounted switchgear maintenance activity should include a physical inspection of the unit, a fluid level check, and fluid testing as described in the **Fluid testing** section of this manual.

Types of fluid samples

The unit must be de-energized before collecting a fluid sample. Collecting a fluid sample from a unit that has critically low fluid levels could result in flashover and unit failure when the unit is re-energized. Never energize this equipment without ensuring that it is filled to the proper fluid level with clean, dry insulating fluid.

The fluid sampling procedure requires that two types of fluid samples be taken.

1. A bulk fluid sample to be used for general fluid tests. Approximately one quart (one liter), taken in accordance with ASTM D923 (latest revision), is required.
2. A "gas-tight" fluid sample, taken in accordance with ASTM D3613 (latest revision), for diagnosis and fault gas analysis.

Fluid sampling guidelines

WARNING

Hazardous voltage. This equipment must be de-energized and grounded prior to conducting any maintenance, dielectric fluid sampling, or dielectric fluid filling procedures. Failure to comply can result in death or severe personal injury.

T239.2

Use the following fluid sampling guidelines to prevent contamination and to safely extract fluid samples:

1. De-energize and ground the switchgear prior to sampling fluid.
2. Where local governing authorities allow access to energized equipment, the following precautions must be taken:

DANGER

Hazardous voltage. Contact with hazardous voltage will cause death or severe personal injury. Follow all locally approved safety procedures when working around high- and low-voltage lines and equipment.

G103.3

WARNING

Hazardous voltage. Always use a shotgun stick when working with this equipment. Failure to do so could result in contact with high voltage, which will cause death or severe personal injury.

G108.0

- a. A hotstick tool capable of uncapping, opening, and collecting fluid from the fluid sampling valve should be used to keep personnel away from the energized bushings.

WARNING

This equipment is not intended to protect human life. Follow all locally approved procedures and safety practices when installing or operating this equipment. Failure to comply can result in death, severe personal injury and equipment damage.

G102.1

- b. Personnel authorized to access energized equipment be properly trained in locally approved safety procedures and utilize locally approved personal protection equipment.

WARNING

Do not operate this equipment if energized parts are not immersed in dielectric fluid. Operation when parts are not properly immersed in dielectric fluid may result in internal flashovers that will damage the equipment and can cause death or severe personal injury.

G104.4

- c. Check switchgear fluid level prior to extracting a fluid sample. If the fluid level is low, do not attempt to extract a sample.
- d. A means to plug the fluid sampling valve should be readily available in the event the valve is unable to close and fluid continues to flow.

Type PST Model-9 Automatic Source Transfer Switchgear with iST Control

WARNING

The switchgear tank must have neutral or positive internal pressure prior to extracting a fluid sample. Negative internal pressure may cause air to enter the tank during sampling which can reduce the fluid's dielectric strength. This may result in internal flashovers that will damage the equipment and can cause death or severe personal injury.

- e. Neutralize internal tank pressure by pulling on the pressure relief device ring prior to opening the sampling valve.
3. Fluid samples should only be extracted when fluid temperatures are 59 °F (15 °C) or higher. Moisture analysis results may not accurately reflect the amount of moisture inside the switchgear if samples are extracted when the fluid is below this temperature.
4. The container temperature must be equal or greater than the ambient air temperature to prevent condensation after opening the container.
5. Never sample fluid during inclement weather (rain, sleet, or snow). The fluid sample could be contaminated by moisture.
6. Always use the drain plug and sampler located near the bottom of the front plate of the tank to extract fluid samples.
7. Use only approved, new fluid-resistant tubing (nitrile or silicone rubber) for sampling the fluid. Use of previously used tubing or incompatible materials can result in contamination of the fluid sample. Tube ID required for the fluid sampling valve is 5/16-inch.
8. The fluid sampling valve and cap should be "finger tight." Use lineman's pliers or tongue and groove pliers to loosen the cap and/or valve if needed. Fluid should start to flow from the valve after 2 – 3 counterclockwise turns.
Note: Do not attempt to turn the valve more than 5 full turns. The valve will completely uncouple after 8 turns and allow fluid to flow freely. If fluid does not flow from the valve after 5 turns and the tank has been de-pressurized, re-tighten the valve, and contact the manufacturer for further instructions.
9. Using a disposable container (not the container that will be sent to the lab), extract one quart of fluid from the sample valve, and discard it as waste.
10. Use only glass or extruded metal (solderless) containers to store fluid for laboratory analysis. Plastic containers must not be used as water vapor can permeate through plastic and alter the results.
11. If dissolved gas analysis is required, the sample must be collected using a glass syringe designed for this purpose.

12. Label the sample container with the switchgear serial number, sample date, and temperature at the time of extraction.
13. Rinse sample container with fluid before extracting a sample. Fill sample container with fluid to 1/3 of the container volume, rinse, and discard rinse fluid.
14. Always fill sample containers to the top to prevent ambient air from altering the moisture content of the sample. Leave ~1 inch of air space in the container to account for thermal expansion.
15. Retighten sampling valve to "finger tight" plus a 1/4 turn. Reinstall cap, and leave it "finger tight."
16. Upon completion of sampling, recheck the switchgear fluid level, and add fluid if required.

Fluid fill guidelines

The fluid level indicator sight gauge on the front plate of the switchgear provides a convenient method to check fluid levels. The indicator provides the correct level for oil at 68 °F (20 °C).

If the fluid level is low, use the following procedure to add dry insulating fluid to fill the unit to the correct level:

1. De-energize and ground the switchgear prior to fluid filling.
2. Use only insulating fluid that complies with ASTM D3487 (latest revision). The fluid must have a minimum dielectric strength of 30 kV when tested per ASTM D877. Never use fluid that contains PCB's (Polychlorinated Biphenyls).
3. Use only transfer equipment that uses insulating fluid resistant materials for hoses, seals, valves, pumps, etc. Failure to use proper transfer equipment can result in contamination of the fluid.
4. When adding fluid, use the fluid fill plug located on the front plate of the unit.
5. Avoid getting gas bubbles in the fluid during filling. Gas bubbles in the fluid can reduce the dielectric strength.
6. When filling is complete, check the fluid level gauge to verify that the fluid is filled to the correct level. Allow at least one hour for gas bubbles to dissipate prior to energizing the unit.
7. Replace fluid fill plug and energize the unit.
8. Record the date and the amount of fluid needed to re-fill the unit; retain information with the permanent maintenance record of the unit.

Fluid testing

The insulating fluid in this equipment has been tested to meet the requirements of ASTM D3487, and it has been processed to remove moisture and dissolved gases. It must be tested on a regular basis in order to ensure that it meets these requirements.

Two types of fluid tests are required to evaluate and maintain the quality of the insulating fluid. They are general fluid tests and dissolved gas analysis.

General fluid tests

The general fluid test requirements are taken from IEEE Std C57.106™-2002, *IEEE Guide for Acceptance and Maintenance of Insulating Oil in Equipment*. The required fluid tests and acceptable limits for service-aged fluid are shown in **Table 5** and **Table 6**.

Fluid test results that do not meet the requirements may indicate a problem with either the fluid or the unit. Contact your Eaton representative for technical assistance.

Table 5. Test limits for service-aged fluid

Fluid Test	Method	Requirement
Dielectric Strength	D877	26 kV minimum
Acid Number*	D974	0.20 mg KOH/g maximum
Dissipation Factor*	D924	1.0% maximum
Interfacial Tension*	D971	24 mN/m minimum
Moisture Content	D1533	See Table 6

*Requirements shown are for mineral oil only. Service-aged limits for ester fluids have not been established at the time of this publishing.

Table 6. Service recommendations for insulating fluid moisture contents

Fluid type	Moisture content (ppm)	Service recommendation
Mineral oil	< 25	Continue with Eaton recommended maintenance schedule (inspection and sampling every 2 years).
	25 – 35	Obtain another oil sample for moisture analysis in 6 months to determine if moisture levels are rising. Refer to the Fluid sampling guidelines section in this manual. If moisture levels increase, determine leak point and repair. Process or replace the fluid if water content has exceeded 35 ppm.
	> 35	De-energize the equipment immediately. Take another sample and verify results. If verified, process or replace the fluid before returning to service.
E200	< 800	Continue with Eaton recommended maintenance schedule (inspection and sampling every 2 years).
	800 – 1200	Obtain another oil sample for moisture analysis in 6 months to determine if moisture levels are rising. Refer to the Fluid sampling guidelines section in this manual. If moisture levels increase, determine leak point and repair. Process or replace the fluid if water content has exceeded 1200 ppm.
	> 1200	De-energize the equipment immediately. Take another sample and verify results. If verified, process or replace the fluid before returning to service.

Dissolved gas analysis

Dissolved gas analysis is a useful technique for diagnosing abnormal conditions and assessing the “normal” condition of fluid in fluid-filled equipment. The method employed is ASTM D3612, which is used in conjunction with IEEE C57.104™-2008 standard, *IEEE Guide for the Detection and Determination of Generated Gases in Oil-Immersed Transformers and their Relations to the Serviceability of the Equipment*. **Table 7** provides recommendations on dissolved gas levels in fluid-insulated switchgear.

Type PST Model-9 Automatic Source Transfer Switchgear with iST Control

Table 7. Dissolved gas in insulating fluid maintenance chart

Acetylene Level C ₂ H ₂	Total Combustible Gas	Required Action
Less than 35 ppm	Less than 500 ppm	<i>Normal Level</i> Resample per routine maintenance schedule.
35 – 50 ppm	500 – 1000 ppm	<i>Caution Level</i> Resample at 3 – 6 months to establish trend; maintain fluid if gas levels increase to hazardous level.
More than 50 ppm	More than 1000 ppm	<i>Hazardous Level</i> Remove unit from service and maintain the fluid.

Testing

All pad-mounted switchgear is carefully tested and adjusted at the factory to operate according to published data. Well-equipped test facilities, a detailed testing procedure, and thoroughly trained personnel assure accurately calibrated equipment. Each unit leaves the factory ready for installation.

Pre-installation testing is not necessary. However, should verification of switchgear operation prior to installation be required, the vacuum interrupters can be tested using the following procedures

High-potential withstand testing of vacuum interrupters

High-potential withstand tests can be performed to check the vacuum integrity of the interrupters used in VFI switchgear.

Safety requirements

To prevent accidental contact with high-voltage parts, the switchgear and high-voltage transformer must be placed in a suitable test cage and all proper grounding procedures must be observed.

WARNING

Hazardous voltage. The switchgear (apparatus and control) and high-voltage transformer must be in a test cage or similar protected area to prevent accidental contact with the high-voltage parts.

Solidly ground all equipment. Failure to comply can result in death, severe personal injury, and equipment damage.

T221.5

CAUTION

Radiation. At voltages up to the specified test voltages, the radiation emitted by the vacuum interrupter is negligible. However, above these voltages, radiation injurious to personnel can be emitted. See *Service Information S280-90-1, Vacuum Interrupter Withstand Test Voltage Ratings Information* for further information.

G109.2

With the PT disconnect switches (rotatable switches below source bushings, see **Figure 3**) and the vacuum interrupters (manual operating handle(s)) in the Open position, perform an AC high-potential test for one minute (or 15 minutes for DC) across each open vacuum interrupter assembly at the voltages shown in **Table 8**. The interrupter should withstand the test voltage and should not load down the source. When complete, ensure that the PT disconnect switches are returned to the closed position.

Table 8. High-potential withstand test voltages

VFI Voltage Rating (kV)	High-Potential Test Voltages
15	25 kV ac RMS or 36 kV dc
25	30.0 kV ac RMS or 42.4 kV dc
35	37.5 kV ac RMS or 74.2 kV dc

Replacement parts

Only factory-authorized replacement parts are to be used for Eaton's Cooper Power series Distribution Switchgear products. Replacement parts are available through the factory Service Department. To order replacement parts, refer to the nameplate and provide the product type, serial number, catalog number, voltage rating, and a description of the part. Contact your Eaton representative for additional information and ordering procedures. The following documents are also available for common field repairs and procedures:

- MN285009EN – Cover gasket replacement, cover installation, leak check procedures and fluid sampling procedures.
- MN285007EN – Visible break window replacement procedure.

This page is intentionally left blank.

Type PST Model-9 Automatic Source Transfer Switchgear with iST Control

This page is intentionally left blank.

This page is intentionally left blank.



Eaton
1000 Eaton Boulevard
Cleveland, OH 44122
United States
Eaton.com

Eaton's Power Systems Division
2300 Badger Drive
Waukesha, WI 53188
United States
Eaton.com/cooperpowerseries

© 2018 Eaton
All Rights Reserved
Printed in USA
Publication No. MN285002EN
April 2018
KA20480735 Rev: 02

Eaton is a registered trademark.

All trademarks are property
of their respective owners.

For Eaton's Cooper Power series product
information, call 1-877-277-4636 or visit:
www.eaton.com/cooperpowerseries.