

DC motor operator control installation and operation instructions

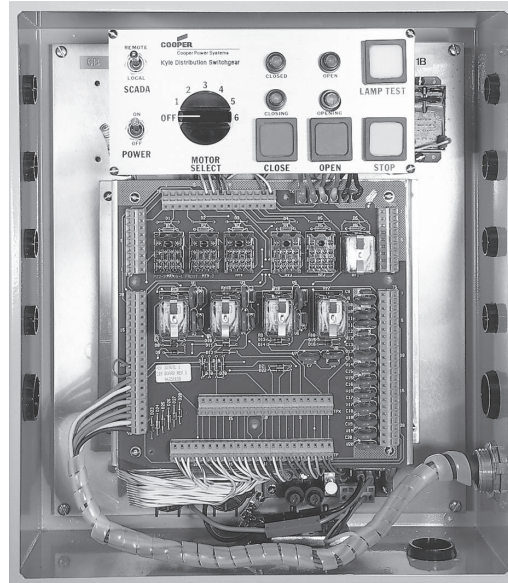

DISCLAIMER OF WARRANTIES AND LIMITATION OF LIABILITY

The information, recommendations, descriptions and safety notations in this document are based on Eaton Corporation's ("Eaton") experience and judgment and may not cover all contingencies. If further information is required, an Eaton sales office should be consulted. Sale of the product shown in this literature is subject to the terms and conditions outlined in appropriate Eaton selling policies or other contractual agreement between Eaton and the purchaser.

THERE ARE NO UNDERSTANDINGS, AGREEMENTS, WARRANTIES, EXPRESSED OR IMPLIED, INCLUDING WARRANTIES OF FITNESS FOR A PARTICULAR PURPOSE OR MERCHANTABILITY, OTHER THAN THOSE SPECIFICALLY SET OUT IN ANY EXISTING CONTRACT BETWEEN THE PARTIES. ANY SUCH CONTRACT STATES THE ENTIRE OBLIGATION OF EATON. THE CONTENTS OF THIS DOCUMENT SHALL NOT BECOME PART OF OR MODIFY ANY CONTRACT BETWEEN THE PARTIES.

In no event will Eaton be responsible to the purchaser or user in contract, in tort (including negligence), strict liability or otherwise for any special, indirect, incidental or consequential damage or loss whatsoever, including but not limited to damage or loss of use of equipment, plant or power system, cost of capital, loss of power, additional expenses in the use of existing power facilities, or claims against the purchaser or user by its customers resulting from the use of the information, recommendations and descriptions contained herein. The information contained in this manual is subject to change without notice.

Contents

DISCLAIMER OF WARRANTIES AND LIMITATION OF LIABILITY	ii
Safety instructions	iv
PRODUCT INFORMATION	1
Introduction	1
Additional information	1
Acceptance and initial inspection	1
Handling and storage	1
Quality standards	1
Control battery storage and charging	1
Control power	2
DESCRIPTION OF CONTROL	2
Control operation	2
Auxiliary contacts	2
Simultaneous indication for SCADA	2
Electrical interlocks	2
Control operation-local mode	3
Local mode operation	3
Local mode features	3
Battery charger board	3
Instructions for LOCAL mode operation	6
SCADA Operation	6
REMOTE Mode Features	6
Extended control accessory	7
Extended control accessory operation	7
Control operation – extended control	7
SCADA Terminal block connection procedures	9
DC Motor actuator	9
TESTING PROCEDURES	9
Battery test	9
Lamp test	9
MAINTENANCE INFORMATION	10
Maintenance program	10
Replacement parts	10



Safety for life



Eaton meets or exceeds all applicable industry standards relating to product safety in its Cooper Power™ series products. We actively promote safe practices in the use and maintenance of our products through our service literature, instructional training programs, and the continuous efforts of all Eaton employees involved in product design, manufacture, marketing, and service.

We strongly urge that you always follow all locally-approved safety procedures and safety instructions when working around high-voltage lines and equipment, and support our “Safety For Life” mission.

Safety information

The instructions in this manual are not intended as a substitute for proper training or adequate experience in the safe operation of the equipment described. Only competent technicians who are familiar with this equipment should install, operate, and service it.

A competent technician has these qualifications:

- Is thoroughly familiar with these instructions.
- Is trained in industry-accepted high- and low-voltage safe operating practices and procedures.
- Is trained and authorized to energize, de-energize, clear, and ground power distribution equipment.
- Is trained in the care and use of protective equipment such as arc flash clothing, safety glasses, face shield, hard hat, rubber gloves, clampstick, hotstick, etc.

Following is important safety information. For safe installation and operation of this equipment, be sure to read and understand all cautions and warnings.

Hazard Statement Definitions

This manual may contain four types of hazard statements:

DANGER

Indicates an imminently hazardous situation which, if not avoided, will result in death or serious injury.

WARNING

Indicates a potentially hazardous situation which, if not avoided, could result in death or serious injury.

CAUTION

Indicates a potentially hazardous situation which, if not avoided, may result in minor or moderate injury.

NOTICE

Indicates a potentially hazardous situation which, if not avoided, may result in equipment damage only.

Safety instructions

Following are general caution and warning statements that apply to this equipment. Additional statements, related to specific tasks and procedures, are located throughout the manual.

DANGER

Hazardous voltage. Contact with hazardous voltage will cause death or severe personal injury. Follow all locally-approved safety procedures when working around high- and low-voltage lines and equipment.

G103.3

WARNING

Before installing, operating, maintaining, or testing this equipment, carefully read and understand the contents of this manual. Improper operation, handling, or maintenance can result in death, severe personal injury, and equipment damage.

G101.0

WARNING

This equipment is not intended to protect human life. Follow all locally-approved procedures and safety practices when installing or operating this equipment. Failure to comply can result in death, severe personal injury, and equipment damage.

G102.1

WARNING

Power distribution and transmission equipment must be properly selected for the intended application. It must be installed and serviced by competent personnel who have been trained and understand proper safety procedures. These instructions are written for such personnel and are not a substitute for adequate training and experience in safety procedures. Failure to properly select, install, or maintain power distribution and transmission equipment can result in death, severe personal injury, and equipment damage.

G122.2

WARNING

Overlapping zones of protection are required. Upstream protection device settings must provide adequate overcurrent protection in the event of a system or product failure. Failure to properly select appropriate upstream coordination protection can result in death, severe personal injury, and equipment damage.

G172.0

Product information

Introduction

Service Information MN285018EN provides installation and operating instructions for Eaton's Cooper Power series DC Motor Operator control. Before installing and operating this control, carefully read and understand the contents of this manual.

Additional information

These instructions do not claim to cover all details or variations in the equipment, procedures, or process described, nor to provide directions for meeting every possible contingency during installation, operation, or maintenance. When additional information is desired to satisfy a problem not covered sufficiently for the user's purpose, contact your Eaton representative.

Acceptance and initial inspection

Each Motor Operator control is completely assembled, tested, and inspected at the factory. It is carefully calibrated, adjusted, and in good condition when accepted by the carrier for shipment.

Upon receipt, inspect the equipment for signs of damage. Inspect the control thoroughly for damage incurred during shipment. If damage is discovered, file a claim with the carrier immediately.

Handling and storage

Be careful during handling and storage of the control to minimize the possibility of damage. If the control is to be stored for any length of time prior to installation, provide a clean, dry storage area. If storage is in a humid atmosphere, make provisions to keep the control circuitry energized. Ensure that the battery is disconnected during storage.

Quality standards

ISO 9001 Certified Quality Management System.

Control battery storage and charging

The 24 Vdc control battery is fully charged prior to shipment and is ready for use. The 2.5 amp-hour sealed lead acid jell-cell battery supplies the energy to activate the motors and the control functions. The battery is capable of running a motor for up to 25 open and 25 close operations before recharge.

The 24 Vdc battery is charged by the temperature/voltage regulated battery charger. The charger will provide an ideal charge voltage based on the ambient temperature. The battery charger will charge at a rate of 0 to 0.3 amps, depending on battery voltage, and will return the battery from low charge to full charge in 24 hours. Nominal battery life is approximately six years.

If the battery is removed from the control for long term storage, or if spare batteries require charging prior to being put into service, a plug-in, bench-type, 2.5 amp-hour battery charger is available, identified by the following catalog number:

KME4-85-3 (120 Vac)

Note: When shipped from the factory, the battery is disconnected. Connect the battery plug into the mating connector to complete the battery circuit.

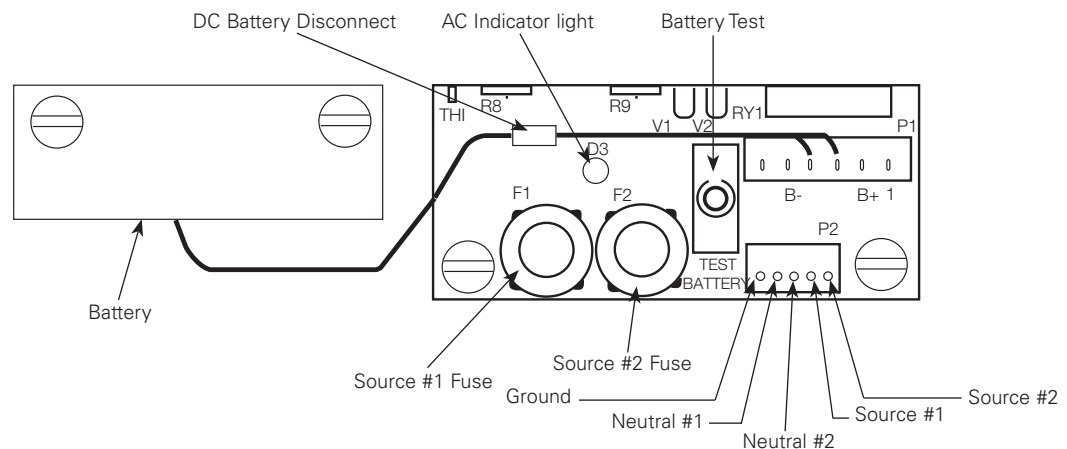
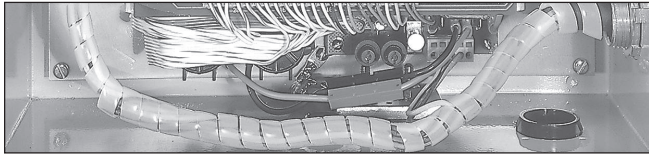

Figure 1. Outline diagram of AC supply and battery charger board

DC motor operator control

Control power

The control requires 120 Vac (104-127 Vac) to operate the battery charger. An additional 120 Vac input with a flip-flop relay will be provided for preferred/alternate voltage sources (See **Figure 2** and **Figure 3**).



941195KM

Figure 2. AC supply and battery charger board

Description of control

Control operation

The DC motor operator control is designed for use with Eaton’s Cooper Power series Type RVAC and VFI pad-mounted switchgear. The motor operator control is applicable with both 600 amp vacuum loadbreak switch mechanisms and vacuum fault interrupter mechanisms.

The motor operator control is designed to monitor and direct the operation of DC motors when supplied with Type RVAC and VFI pad-mounted switchgear. The control will operate up to six motor actuators-one at a time-in a user-selected random order for 25 OPEN and 25 CLOSE operations without line voltage.

The basic DC control can be operated in either the LOCAL or REMOTE modes by making the appropriate selection with the SCADA toggle switch. With the SCADA switch on LOCAL, STATUS and control functions are accessed via the control panel. With the SCADA switch on REMOTE, STATUS and control functions are accessed via the SCADA interface (See **Figure 4** and **Figure 6**).

Auxiliary contacts

One “a” and one “b” auxiliary switch contact from the “B” phase of each actuated mechanism are utilized for status indication. To read status in either LOCAL or REMOTE modes, a motor must first be selected.

Simultaneous indication for SCADA

For some SCADA applications, it may be necessary to monitor the status of each stage simultaneously. To provide this capability, an additional stage for each actuated mechanism is required. For these applications, an optional interface, separate from the control, can be additionally provided (consult factory for details).

Electrical interlocks

The DC motor operator control may be supplied with the capability for user-specified electrical interlocking. For these applications, an additional stage may be required (consult factory for details).

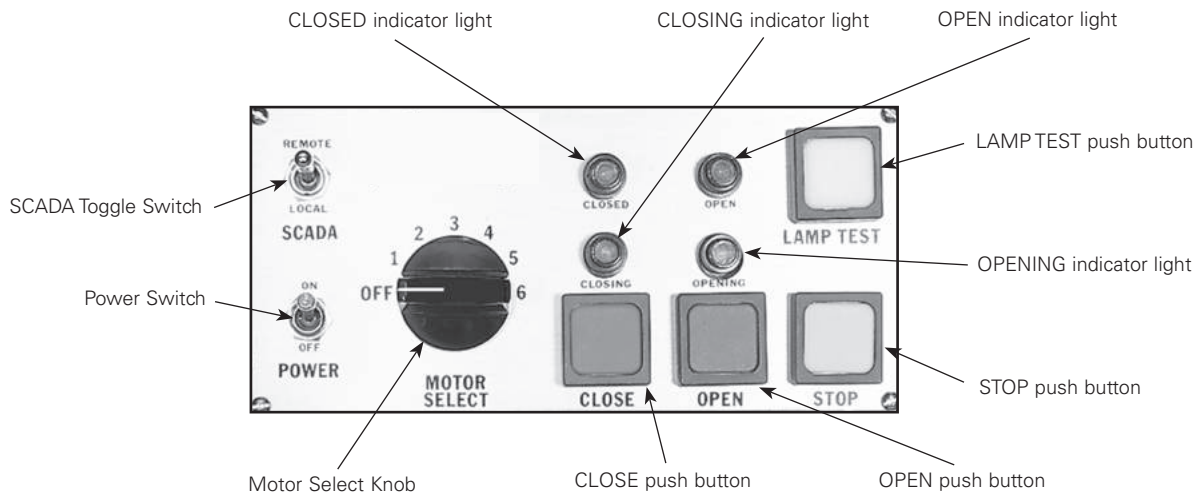

941194KM

Figure 3. Operator panel of DC motor operator control

Control operation-local mode

The operator panel is located inside, and at the top, of the control cabinet. The operator panel contains the power toggle switch, the SCADA toggle switch, the motor select knob, the operation switches, and the status indicators. (See **Figure 4**).

Local mode operation

Status and control operation are provided via the operator panel. The control is activated in the LOCAL mode when the SCADA toggle switch is set to LOCAL.

Operations capabilities from the control panel:

- Select local or remote operation.
- Select one of several motors.
- Read status of selected motor.
- Operate the selected motor.
- Monitor opening or closing action.
- Test indicating lights.
- Read status of 120 Vac.
- Disconnect 120 Vac.
- Test battery (with user-supplied volt meter).
- Disconnect 24 Vdc.

Local mode features

Features and capabilities of the DC motor operator control, which can be accessed from the control panel, are described as follows:

POWER SWITCH (ON/OFF TOGGLE): Disconnects the DC voltage to the control and motors. When the Power switch is in the OFF position, all control features are inactive with the exception of the battery test feature. The AC supply will be unaffected.

SCADA SWITCH (TOGGLE): In the Local position, prevents the operation of Open, Close, and Motor selection from the SCADA terminals. Operation of the motor operator is only possible from the control panel. Conversely, placing the SCADA toggle switch in the REMOTE position prevents the operation of Open, Close, and Motor selection from the control panel. Operation of the motor operator is only possible via the SCADA terminal points. (Also see **“Control operation – extended control”**).

MOTOR SELECT SWITCH (ROTARY): Selects which motor is active for status indication and operation. This switch should be returned to the OFF position after operation is completed to disable the panel indicating lights so as to avoid battery drain.

CLOSE (RED PUSH BUTTON): Closed the selected switch or interrupter mechanism via the motor operator.

OPEN (GREEN PUSH BUTTON): Opens the selected switch or interrupter mechanism, via the motor operator.

STOP (YELLOW PUSH BUTTON): Stops the motor-operated opening or closing action of the selected switch or interrupter mechanism.

Note: Mechanisms should not be left between an open and closed position. A mis-operation could occur. Restart the motor and actuate to a fully OPEN or fully CLOSED position.

LAMP TEST (WHITE PUSH BUTTON): Checks status indicator lights by energizing all lights.

CLOSED INDICATION (RED LIGHT): Indicates that the selected switch or interrupter mechanism is in the CLOSED position.

OPEN INDICATION (GREEN LIGHT): Indicates that the selected switch mechanism is in the OPEN position. It also indicates that the fault interrupter mechanism is in either the OPEN or TRIPPED position.

CLOSING INDICATION (YELLOW LIGHT): Indicates that the motor actuator is closing the selected switch or interrupter mechanism.

OPENING INDICATION (YELLOW LIGHT): Indicates that the motor actuator is opening the selected switch or interrupter mechanism.

Note: Do not move MOTOR SELECT switch during motor operation as motor will halt partially operated and actuation may transfer to new motor selection.

Do not leave motor partially operated. The interrupter may be on the verge of operating. Complete actuation to either the fully open or fully closed position.

IMPORTANT

The VFI mechanism is a trip-free mechanism. If the VFI is closed by a motor operator and a fault occurs, the handle will be held in the CLOSED position, but the VFI mechanism will trip and the control panel will indicate OPEN. To reset the VFI, select the correct motor and push the OPEN pushbutton. The motor operator will open and reset the VFI. The VFI can then be closed by pushing the CLOSE push button.

Battery charger board

The battery charger, battery test pushbutton, AC indicator light, fuses, and 120 Vac terminals are located inside, and at the bottom of, the control housing. See **Figure 2** and **Figure 3**.

The charger board can receive 120 Vac from either of the two 120 Vac sources which can be connected simultaneously through the supply terminals (See **Figure 2** and **Figure 3**). Each 120 Vac supply is fused on the board with a 1A fuse.

DC motor operator control

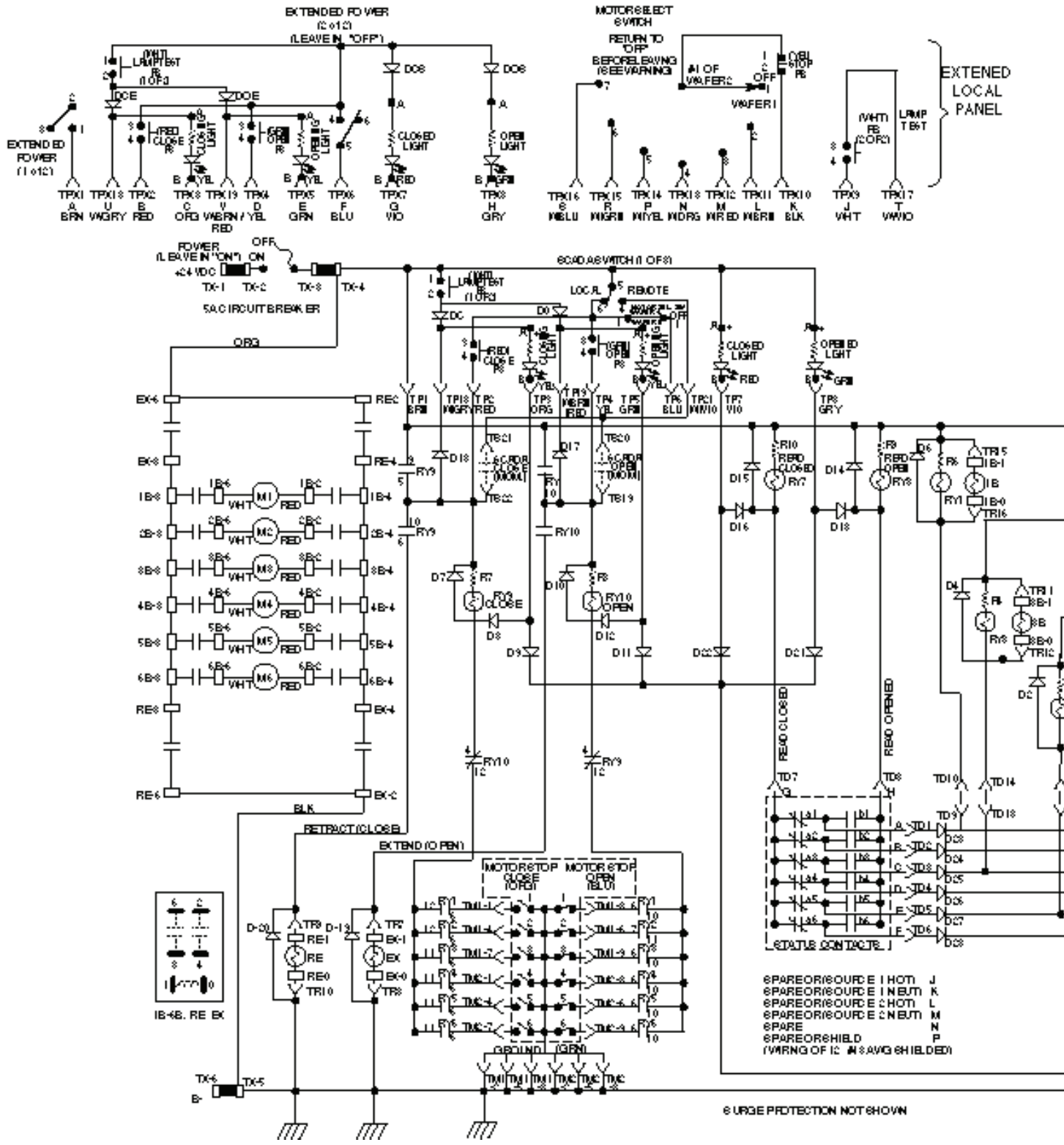
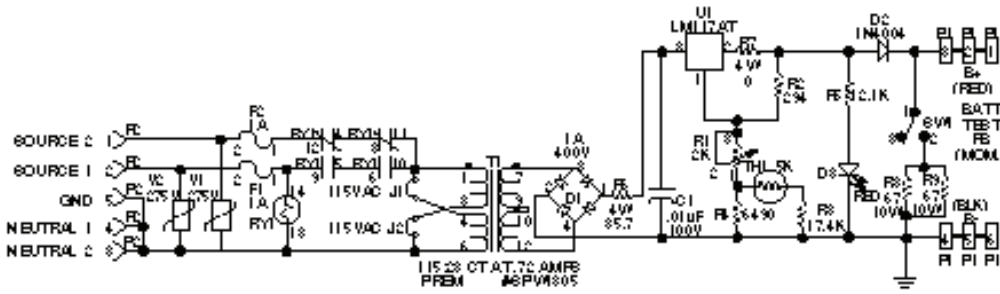
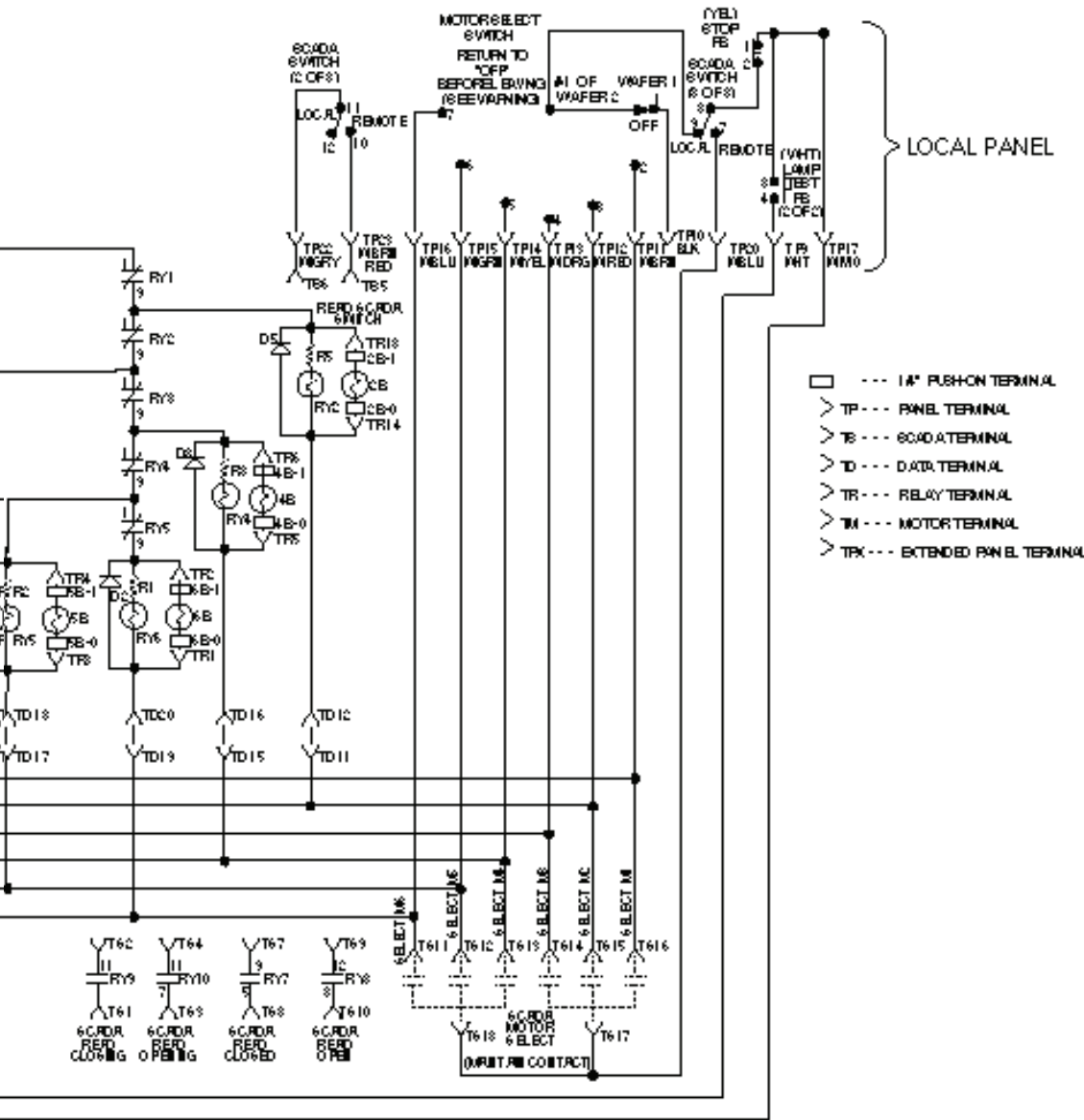

Figure 4. Wiring schematic of DC motor operator control



NOTES: 1. R1 IS ADJUSTED TO 2% PEAK VOLT WITH LOAD RESISTOR OF 11.8K OHMS +A1 / VISA SCOPE



TERMINAL "TRX" POSITIONS GO TO 64MM ENUMBER POSITIONS ON TERMINAL "TP"

Note: This is a typical schematic diagram for standard Motor Operator Control. Refer to the schematic diagrams supplied with your control for specific information on accessories or special modifications that were supplied at the time of manufacture. Dashed wires indicate customer-made connections.

DC motor operator control

Instructions for LOCAL mode operation

For DC Motor Operator Control wiring and outline information, refer to **Figure 5** and **Figure 8**.

1. POWER switch must remain ON for normal operation. Power OFF disables both control and motors.

The power switch is a 5-amp, DC breaker which will operate in 1 to 3 seconds for 20 amps. Placing the switch in the OFF position disables the DC, which powers both the control and the motors.

2. SCADA switch must be set to LOCAL.

To operate the motors from the control panel, the SCADA switch must be set to LOCAL.

3. Set MOTOR SELECT switch to desired motor.

To read the contact status or to select a motor to operate, set the MOTOR SELECT switch to the desired position.

4. Confirm that the correct status indicators are lit.

After selecting a motor, confirm that the status lights indicate the actual position of the mechanism.

5. Push OPEN or CLOSE pushbuttons to operate motor. Yellow light indicates motor operation in progress. Push STOP to halt motor operation immediately; then push OPEN or CLOSE to complete a full open or full close operation. (See Note below).

Push the appropriate pushbutton to perform the OPEN or CLOSE operation. If necessary, push the STOP pushbutton to halt the motor immediately. Do not leave the motor in this condition. Complete a full OPEN or CLOSE operation to prevent an inadvertent mechanism operation.

6. When complete, return MOTOR SELECT switch to OFF. Set SCADA switch as desired. Leave POWER switch ON to permit SCADA operation.

The status lights will remain lit as long as a motor is selected. If AC power is lost, the batteries will eventually be drained. Be sure to return the MOTOR SELECT switch to the OFF position. Leave the POWER switch on if SCADA operation is desired.

Note: The POWER SWITCH does not disable 120 AC or the battery charger. To disconnect 120 Vac, remove the fuses or disconnect 120 Vac from Terminal P2.

SCADA Operation

Remote monitoring and control operation are provided through the SCADA terminals. The control is activated in the REMOTE mode when the SCADA toggle switch is set to REMOTE.

Features available through SCADA terminals:

- Select one of several motors.
- Read status of selected motor.
- Operate the selected motor.
- Monitor opening or closing action.

REMOTE Mode Features

All remote features are accessed through a terminal strip mounted on the relay circuit board. (See **Figure 6** and **Figure 8**). Remote operation is permitted only when the SCADA switch is in the REMOTE position.

The operation of each feature is described as follows:

MOTOR SELECT CONTACTS: Dry contacts for SCADA selection of a switch or interrupter mechanism for status indication or operation. These contacts require a maintained contact closure for as long as the status is being read or the motor actuator is active.

If this contact is opened during an operation, the motor actuator will stop immediately. If more than one motor is selected simultaneously, the lowest numbered motor will be selected by default.

STATUS CONTACTS: Dry contacts which indicate open or closed status of the switch or interrupter mechanism selected via the SCADA Motor Select Contacts.

CLOSE CONTACT: Dry contact which initiates closing the switch or interrupter mechanism selected via the Motor Select contacts. A momentary contact closure between terminal 21 and terminal 22 on the SCADA terminal strip is required.

OPEN CONTACT: Initiates opening the switch or interrupter mechanism, selected via the Motor Select contact. A momentary contact closure between terminal 19 and terminal 20 on the SCADA terminal strip is required.

CLOSING CONTACT: Dry contact which indicates that the motor actuator is closing the switch or interrupter mechanism selected via the Motor Select contacts. The motor is closing when the contact is closed (terminals 1 and 2).

OPENING CONTACT: Dry contact which indicates that the motor actuator is opening the switch or interrupter mechanism selected via the Motor Select contacts. The motor is opening when the contact is closed (terminals 3 and 4).

SCADA SWITCH POSITION CONTACT: A dry contact which indicates the position of the SCADA switch. When the SCADA switch is in the REMOTE position, this contact will be closed. When the SCADA switch is in the LOCAL position, this contact will be open (terminals 5 and 6).

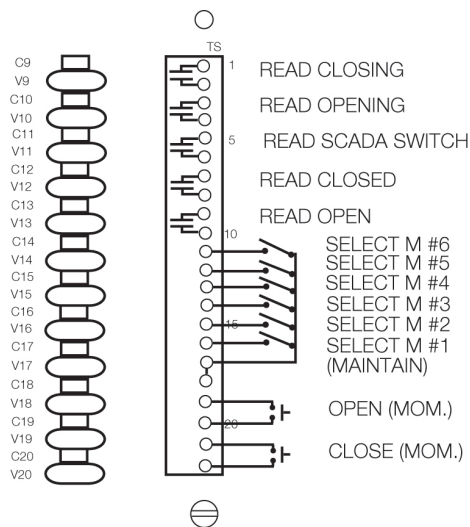

Figure 5. SCADA Terminal block

Extended control accessory

The DC Motor Operator control can be operated via a separate portable control when equipped with the appropriate accessory components. The Extended Control Accessory components include the portable control, the control cable, and modifications to the DC Control (ie: an additional connector and associated wiring). The cable is supplied with a separable connector at both ends and can be supplied in user-specified lengths up to 200 feet.

Note: Modifications to the DC Control should be made at time of manufacture, but can be purchased optionally as a field retrofit kit.



941194KM

Figure 6. Extended control accessory

Extended control accessory operation

The DC Control can be optionally equipped with an accessory which allows the control to be operated (in the LOCAL mode) from an additional portable control panel. Monitoring and operation are provided through the extended control accessory.

Control operation – extended control

With the DC Motor Operator Control SCADA toggle switch set to LOCAL and the rotary MOTOR SELECT switch set to the OFF position, the operation capabilities from the extended control accessory are:

- Select one of several motors.
- Read status of selected motor.
- Operate the selected motor.
- Monitor opening or closing action.
- Test indicating lights.

The operation of each feature is described as follows:

MOTOR SELECT SWITCH (ROTARY): Selects which motor is active for status indication and operation by the extended local control. The SCADA switch must be set to the LOCAL position for extended local control operation.

CLOSE (RED PUSH BUTTON): Closes the selected switch or interrupter mechanism, via the motor operator.

OPEN (GREEN PUSH BUTTON): Opens the selected switch or interrupter mechanism, via the motor operator.

STOP (YELLOW PUSH BUTTON): Stops the motor-operated opening or closing action of the selected switch or interrupter mechanism.

Note: Mechanisms should not be left between an open or closed position. A mis-operation could occur. Restart the motor and actuate to a fully OPEN or fully CLOSED position.

LAMP TEST (WHITE PUSH BUTTON): Checks status indicator lights by energizing all lights.

CLOSED INDICATION (RED LIGHT): Indicates that the selected switch or interrupter mechanism is in the closed position.

OPEN INDICATION (GREEN LIGHT): Indicates that the selected switch mechanism is in the open position. It also indicates that the fault interrupter mechanism is in either the open or tripped position.

CLOSING INDICATION (YELLOW LIGHT): Indicates that the motor actuator is closing the selected switch or interrupter mechanism.

OPENING INDICATION (YELLOW LIGHT): Indicates that the motor actuator is opening the selected switch or interrupter mechanism.

IMPORTANT

The VFI mechanism is a trip-free mechanism. If the VFI is closed by a motor operator and a fault occurs, the handle will be held in the CLOSED position, but the VFI mechanism will trip and the control panel will indicate OPEN. To reset the VFI, select the correct motor and push the OPEN pushbutton. The motor operator will open and reset the VFI. The VFI can then be closed by pushing the CLOSE pushbutton.

DC motor operator control

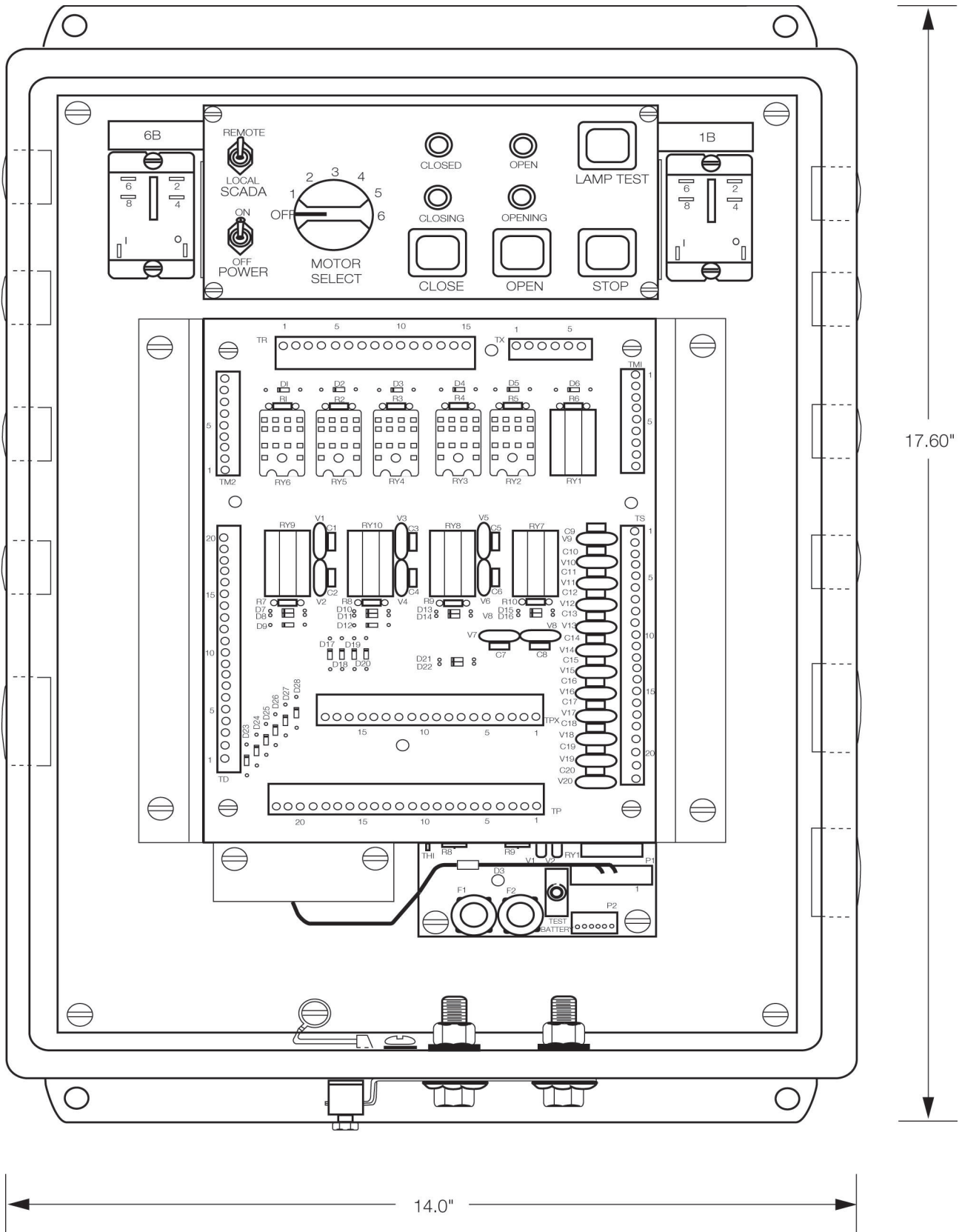

Figure 7. Outline diagram of DC motor operator control

SCADA Terminal block connection procedures

SCADA terminal block connection can be completed via side-entry or front-entry connection. The maximum wire size to be used is #14. The minimum wire size to be used is #26. To connect the SCADA terminal block, use the screwdriver provided in the DC Motor Operator Control cabinet in conjunction with the following instructions (See **Figure 8**):

1. Insert the screwdriver into the operating slot.
2. Insert the stripped wire. Hold the clamping spring open with the screwdriver so that the conductor can be inserted into the clamping unit.
3. Withdraw the screwdriver. The conductor will automatically be clamped.

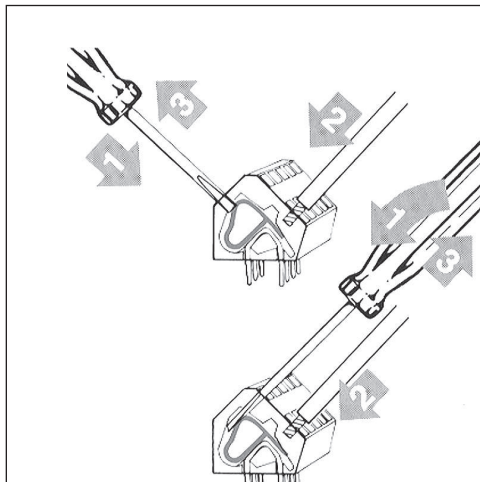

Figure 8. SCADA terminal block connection procedures

DC Motor actuator

The DC Motor Operator Control is designed for operation with the DC Motor Operator. The DC Motor actuates to open or close when supplied with 24 Vdc via the control (See **Figure 9**).



Figure 9. DC Motor actuator - connected

The DC motor actuator can be manually disconnected by removing the quick connect pin that connects the motor link to the yellow handle.



Figure 10. DC Motor actuator - limit switch enclosure

Note: The actuator and limit switches are adjusted for proper operation prior to shipment. However, the limit switch cover can be removed and the limit switches are easily accessible if adjustments are required (See **Figure 10**).

Testing procedures

⚠ WARNING

This equipment is not intended to protect human life. Follow all locally approved procedures and safety practices when installing or operating this equipment. Failure to comply can result in death, severe personal injury and equipment damage.

G102.1

Battery test

1. Remove AC Input for two minutes.
2. Measure Vdc of battery with no load present - positive probe to P1-2 (B+), negative probe to P1-5 (B-, ground) (See **Figure 2**). If less than 23.3 volts, charge battery for 24 hours.
3. Push the white Battery Test push button.

Note: Voltage drop should not exceed two volts.

Lamp test

Push the LAMP TEST (white) pushbutton to check indicator operating lights. This energizes all lights simultaneously. The remote status and operating contacts are not tested.

Maintenance information

WARNING

This equipment requires routine inspection and maintenance to ensure proper operation. If it is not maintained it may fail to operate properly. Improper operation can cause equipment damage and possible personal injury.

G105.1

Maintenance program

A routine maintenance inspection program is required to ensure proper operation of the equipment. Detailed service records should be recorded in the unit's inspection and maintenance record log. Refer to Tables 1 and 2 for typical operating characteristics of the DC Motor Operator Control.

Table 1. DC motor operator ratings

	Close max. (amps)	Open max. (amps)
Running load amperage (RLA)	4.2	1.6
In rush	20	20

Table 2. DC motor operator-operating characteristics

	Close (secs.)	Open (secs.)
	Avg.	Avg.
Motor run time	1.85	1.83

Replacement parts

Replacement parts for the DC Motor Operator Control are available through the factory Service Department. To order parts, contact your Eaton representative for additional information and ordering procedures.

This page intentionally left blank.



Eaton
1000 Eaton Boulevard
Cleveland, OH 44122
United States
Eaton.com

Eaton's Power Systems Division
2300 Badger Drive
Waukesha, WI 53188
United States
Eaton.com/cooperpowerseries

© 2019 Eaton
All Rights Reserved
Printed in USA
Publication No. MN285018EN
February 2019
KA2048-0406 REV02

Eaton is a registered trademark.

All trademarks are property
of their respective owners.

For Eaton's Cooper Power series product
information call 1-877-277-4636 or visit:
www.eaton.com/cooperpowerseries.