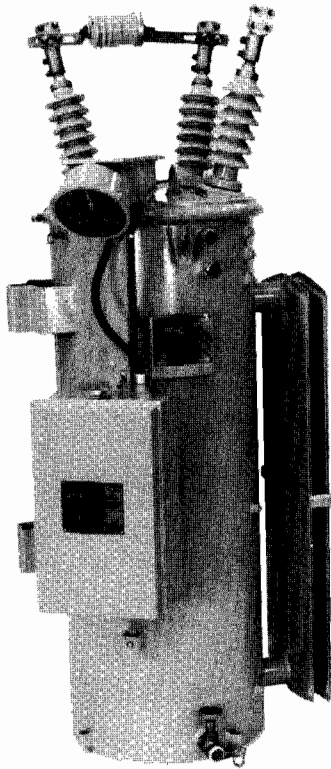
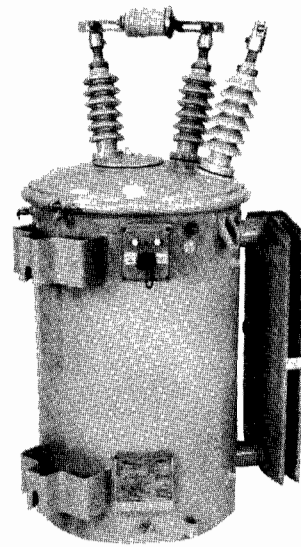


# How Step-Voltage Regulators Operate

---



McGraw-Edison® 32-step Voltage Regulator



Auto-Booster® 4-step Voltage Regulator



---

**Cooper Power Systems**

Quality from  
Cooper Industries

## How Step Voltage Regulators Operate

To measure the quality of electric power, consumers evaluate service continuity and voltage regulation. Heavy air-conditioning and heating loads plus the ever increasing demand for electric energy can tax electric systems beyond acceptable limits. Since all electrical equipment is designed for use within narrow limits, poor voltage conditions can result in undesirable and unacceptable equipment performance such as distorted tv reception, flickering lights and/or burned out motors.

Step-voltage regulators on utility distribution systems deliver dependable voltage levels, to meet customer demands for improved voltage control.

### OPERATION THEORY

A voltage regulator holds line voltage within predetermined limits and assures the proper operation of lights, appliances, and motors. To understand how a regulator operates, one must first understand how a two-winding transformer operates.

Figure 1 is a basic diagram of a transformer with a 10:1 turns ratio. If the primary winding has 1000 volts applied, the secondary winding will have an output of 100 volts. These two independent windings can be connected so that their voltages may aid or oppose one another. A voltmeter connected across the output terminals will measure either the sum of the two voltages or the difference between them. The transformer becomes an auto-transformer with the ability to raise (Figure 2) or lower (Figure 3) the primary or system voltage by 10%. Since the low-voltage winding is operated at the system voltage level, adequate insulation to ground must be incorporated.

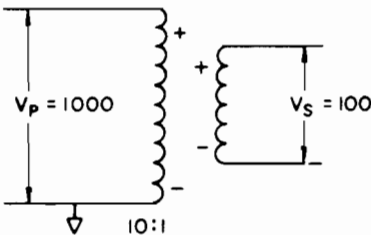


Figure 1. Transformer with 10:1 turns ratio.

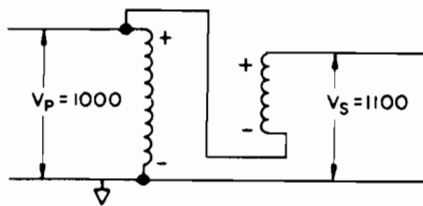


Figure 2. Step-up autotransformer.

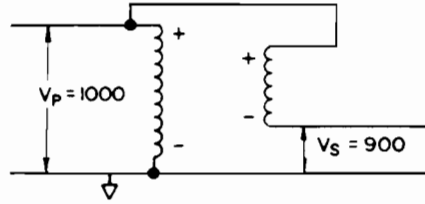


Figure 3. Step-down autotransformer.

Cooper Power Systems offers the conventional McGraw-Edison<sup>®</sup> 32-step voltage regulator, and the Auto-Booster<sup>®</sup> four-step regulator. The basic operation is the same for both 32-step regulators (which use a reactor for switching) and the 4-step regulator (which uses resistors for switching).

There are two types of step voltage regulator construction which are defined by the American National Standards Institute (ANSI). These are ANSI type "A" and "B." These are also known as "straight" (type A) and "inverted" (type B) designs.

The internal electrical construction of these regulators differ; however, the external construction, connection to the utility electrical system, and use is the same.

All Auto-Booster<sup>®</sup> 4 step voltage regulators are "type B" construction. For simplicity the following will discuss only that type.

Type B 32-step and 4-step regulators are connected as shown in Figure 4. This

connection places the low-voltage winding on the source side of the high-voltage winding. An interrelationship between the two windings still exists; however, it is the reverse of that shown in Figures 2 and 3. The voltage increase or decrease takes place ahead of the high-voltage winding; therefore, the voltage measured across the high-voltage winding will be either 900 or 1100 volts. When referring to a regulator, the low-voltage winding is called the series winding; the high-voltage winding is called the shunt winding (Figures 5 and 6).

For greater regulator versatility, taps may be added to the series winding. A control winding completes the transition, sensing the load voltage and supplying this intelligence to the control of an automatic tap changer.

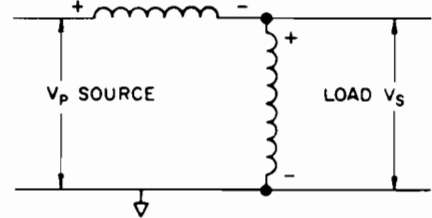


Figure 4. Connection of 32-step and 4-step regulators.

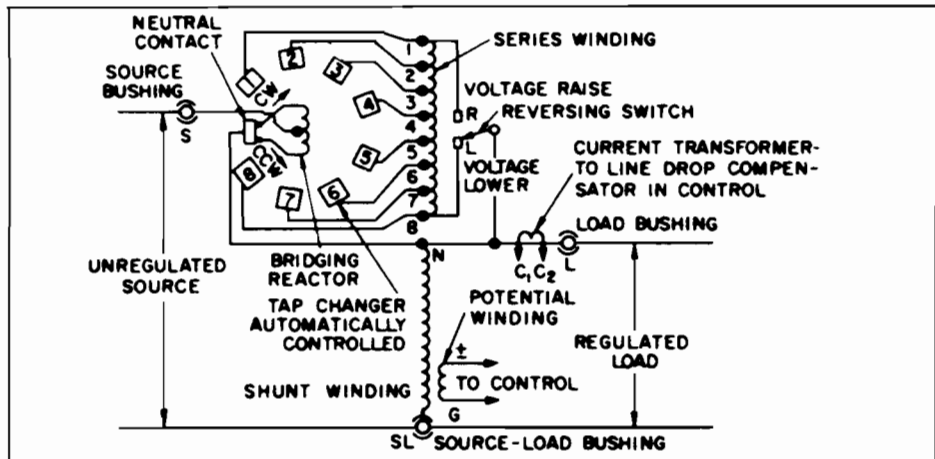


Figure 5. McGraw-Edison<sup>®</sup> 32-step voltage regulator.

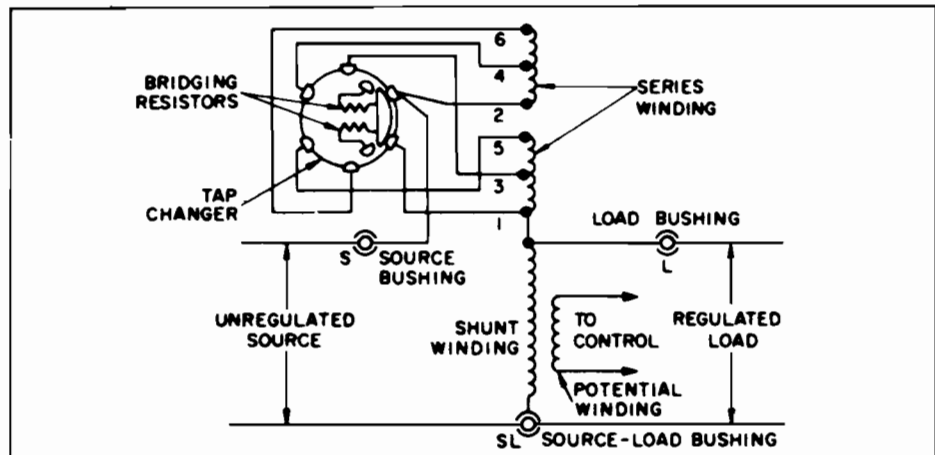
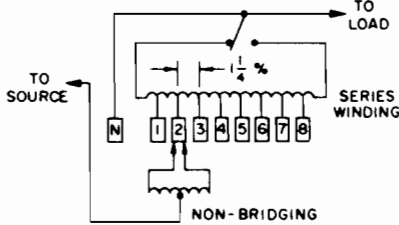


Figure 6. Auto-Booster<sup>®</sup> 4-step voltage regulator.

### To Bridge or Not to Bridge

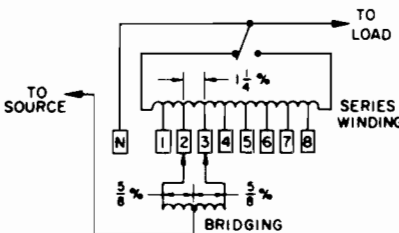
The Auto-Booster voltage regulator steps with no bridging position, while the McGraw-Edison 32-step regulators include the bridging position. Bridging positions decrease voltage steps, improving system voltage less noticeably. A center-tapped reactor connects two movable contacts that are spaced so that one is always on a stationary contact.

Figure 7 shows the two movable contacts on the same stationary contact. With both movable contacts at the same position, the center tap of the bridging reactor is at the same potential.



**Figure 7.** Two movable contacts on the same stationary contact; center tap of the reactor is at the same potential.

Figure 8 shows a bridging position with one movable contact on tap 2, the other on tap 3. The bridging reactor limits the circulating current caused by the two contacts being at different positions. This difference causes the voltage change to be half the  $1\frac{1}{4}\%$  tap voltage of the series winding at the center tap.

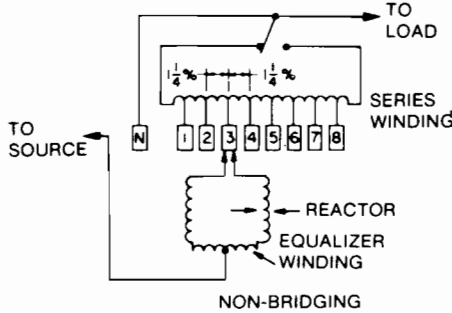


**Figure 8.** Two movable contacts on different taps; voltage change is one-half the  $1\frac{1}{4}\%$  tap voltage of the series winding because of its center tap.

Some regulators, depending on the rating, use an equalizer winding to improve tap changer contact life. An equalizer winding is a  $\frac{5}{8}\%$  winding on the same magnetic circuit as the shunt and series windings. The equalizer winding is connected into the power circuit so that the reactor is excited at  $\frac{5}{8}\%$  of line voltage on both even and odd positions. Figure 9 shows an equalizer winding incorporated into the main coil of a regulator.

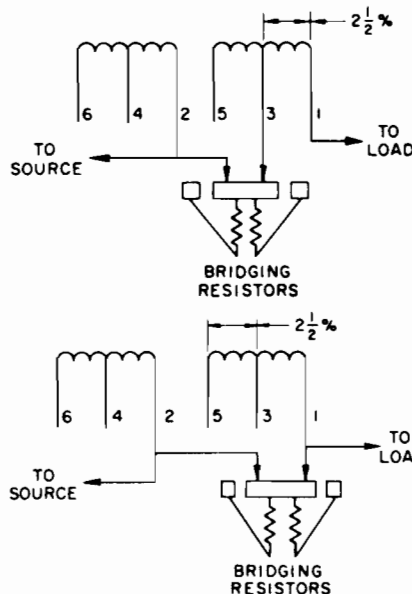
Without an equalizer winding, the reactor on a regulator is not energized on even positions and energized at  $1\frac{1}{4}\%$  of line voltage on odd positions. When an equalizer winding is used, the reactor is designed so the circulating current is maintained at

50% of rated load current when  $\frac{5}{8}\%$  of line voltage is applied. Thus, both the interrupted voltage and the interrupted kVA have been halved, reducing the tap changer interruption duty.



**Figure 9.** An equalizer winding incorporated into the main coil of a regulator.

The Auto-Booster 4-step voltage regulator taps directly from one tap position to the next without a stop at the bridging position (Figure 10). For the 10% voltage regulator shown, every time a tap change occurs, a  $2\frac{1}{2}\%$  voltage change is made. The 6% voltage regulator provides a  $1\frac{1}{2}\%$  voltage change. Although the bridging position is not available as a steady-state condition, circuit continuity during switching can only be obtained if the bridging position is used during the transition period. Bridging resistors prevent excessively high circulating currents from flowing during the switching interval. Bridging resistors have been used extensively in Europe. The main advantages are simplicity and small size.

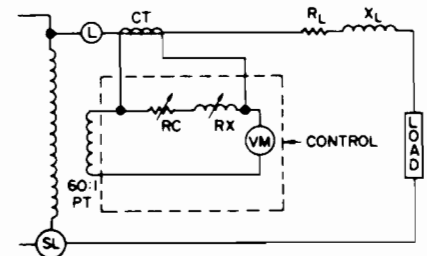


**Figure 10.** The Auto-Booster® 4-step voltage regulator goes directly from one tap position to the next, without a stop at the bridging position.

### Line-Drop Compensation (LDC)

A major difference between the conventional 32-step voltage regulator and the 4-step voltage regulator is the incorporation of line-drop compensation (LDC). This control feature — available with the 32-step voltage regulator only — allows a constant voltage to be maintained at a load center remote from the regulator.

A resistive and a reactive element in the sensing circuit of the control is set to simulate the resistance and reactance of the line from the regulator to the load center. A sampling of the load current current and regulated system voltage is applied to the resistive and reactive elements. A voltage drop proportional to the load on the actual system is obtained across the elements. Because the resistive and reactive elements are in series with the voltage sensing circuit and connected across the load side of the regulator, the additional drop in the LDC circuit reduces the voltage sensed by the sensing circuit. This voltage reduction causes the control to call for additional regulator raise operations. The amount of voltage increase at the regulator is a direct function of the load. This circuit is shown in Figure 11.



**Figure 11.** A typical line-drop compensation (LDC) circuit.

The general criteria for setting LDC are based on whether the regulator location is remote from the load center and whether the load varies greatly during a 24-hour period.

It is difficult to establish exact distance or load variations that would dictate the use of LDC; however, it is important to understand the distribution system, and then meter the voltage variation at the load center. An alternative approach is to place the regulator at or near the load center.

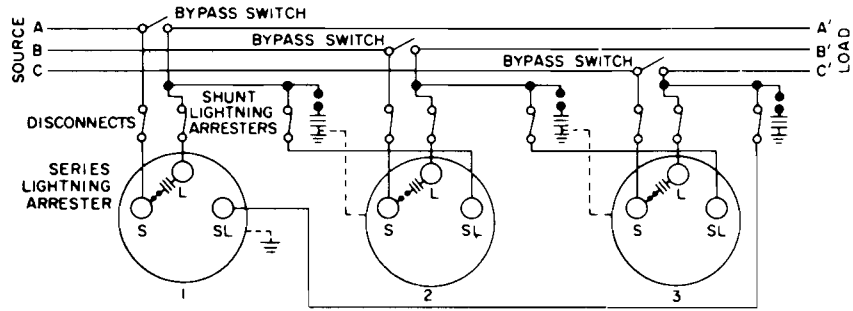
Auto-Booster® 4-step voltage regulators should be applied on laterals or circuits where frequent switching is not required. They are not recommended for use in substations. Use on laterals is recommended when 32-step voltage regulators are used on main feeders and no special coordination is required. The life of the tap changer depends largely on the frequency of switching and the degree of loading.

## TYPES OF CIRCUITS

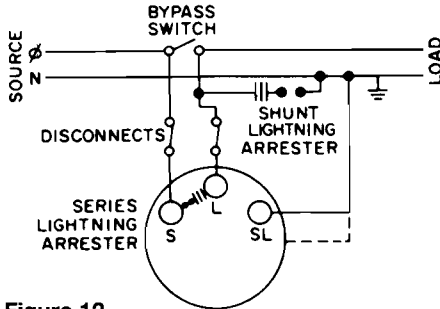
The following types of circuits can be regulated;

- A single-phase circuit (Figure 12);
- One phase of a three-phase wye or delta circuit (Figure 13);
- A three-phase, three-wire wye or delta circuit (Figures 14 and 15);\*
- A three-phase, four-wire, multigrounded wye circuit (Figure 16).

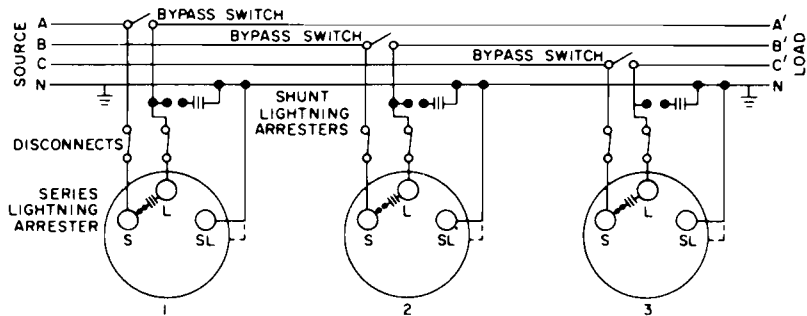
\*Because of possible neutral shift with resulting overstressing of insulation and continual hunting, three regulators cannot be connected in ungrounded wye on a three-phase, three-wire circuit.



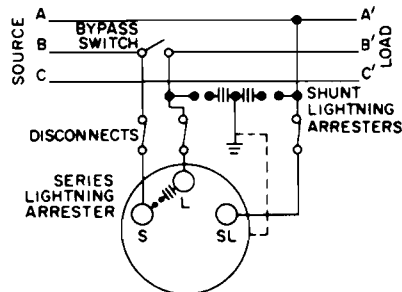
**Figure 15.**  
Regulating a three-phase, three-wire wye or delta circuit with three regulators.



**Figure 12.**  
Regulating a single-phase circuit.

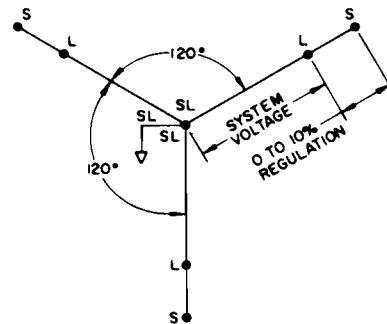


**Figure 16.**  
Regulating a three-phase, four-wire, multigrounded wye circuit with three regulators.



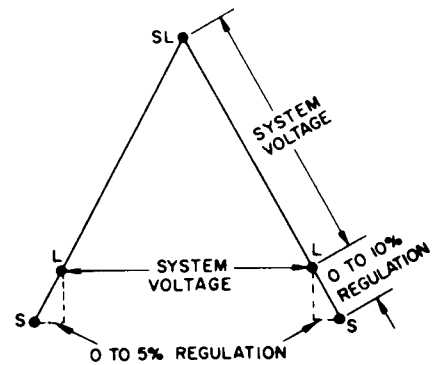
**Figure 13.**  
Regulating one phase of a three-phase, three-wire circuit.

Wye-connected regulators (Figure 17) work independently; delta-connected units are interrelated. Voltage improvement depends on the range of regulation and the voltage on one phase of the system.

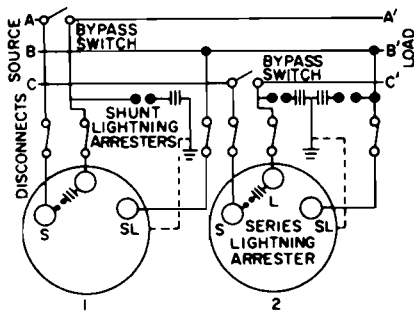


**Figure 17.**  
Wye-connected regulators operate independently.

Figure 18 shows an open-delta connection and the interrelationship between phases. A voltage improvement of 10% in the phase with the regulator connected causes a 5% voltage improvement in the phase without a regulator. When both regulators provide a 5% voltage improvement to the third phase, all three phases are regulated to 10%.



**Figure 18.**  
Open-delta connection has interrelated phases.



**Figure 14.**  
Regulating a three-phase, three-wire or delta circuit with two regulators.

The closed-delta connection (Figure 19) causes a 10% voltage improvement in the connected phase and a 5% improvement in the adjacent phase. As all three phases have regulators connected (Figure 20), the overall effect is to increase the range of regulation to 15%.

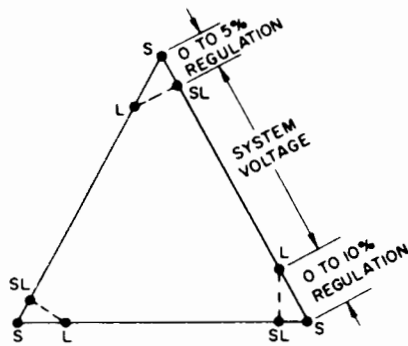


Figure 19. Closed-delta connection regulators.

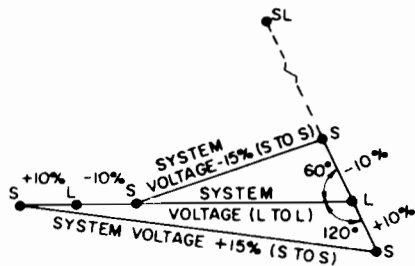


Figure 20. One regulator of closed-delta connection shows range of regulator increased to ±15%.

### DETERMINING REQUIRED REGULATOR TYPE AND SIZE

The circuit determines the type of regulator required. The circuit voltage and kVA ratings and the required amount of voltage correction determine the regulator size.

#### 1. Example

To regulate a three-phase, four-wire, multigrounded wye circuit with a system voltage of 7620/13200 wye and a 1250-kVA connected load that requires a 10% voltage correction:

A. Multigrounded wye circuit indicates grounded-wye regulator connection.

B. Calculation to determine the size of the units:

Rated load in amps

$$= \frac{\text{three-phase kVA} \times 1000}{\text{line-to-line volts} \times 1.732}$$

$$= \frac{1250 \times 1000}{13200 \times 1.732}$$

$$= 54.6 \text{ amps}$$

C. Range in kV:

$$= \text{range} \times \text{line-to-neutral kV}$$

$$= 0.1 \times 7.62$$

$$= 0.762 \text{ kV}$$

D. Regulator rated kVA

$$= \text{load amps} \times \text{range in kV}$$

$$= 54.6 \times 0.762$$

$$= 41.7 \text{ kVA}$$

With the selection of a standard rating, 32-step regulators rated 57.2 kVA, 7620 volts, 75 amps, plus or minus 10% regulation meet the application requirements. Three regulators connected line to neutral are required.

#### 2. Example

To regulate a three-phase, three-wire circuit with a system voltage of 13800 volts and a connected load of 1250 kVA that requires a 10% voltage correction:

A. Three-wire wye or delta circuit.

B. Calculation to determine the size of the units:

Rated load in amps

$$= \frac{\text{three-phase kVA} \times 1000}{\text{line-line volts} \times 1.732}$$

$$= \frac{1250 \times 1000}{13800 \times 1.732}$$

$$= 52.3 \text{ amps}$$

C. Range in kV

$$\text{range} \times \text{line-line kV}$$

$$= 0.1 \times 13.8$$

$$= 1.38 \text{ kV}$$

D. Regulator rated kVA

$$= \text{load amps} \times \text{range in kV}$$

$$= 52.3 \times 1.38$$

$$= 72.2 \text{ kVA}$$

Standard rating, 32-step regulators rated 138 kVA, 13800 volts, 100 amps, plus or minus 10% regulation meet this requirement. Two regulators connected line to line in open-delta connection are required.

### REDUCED RANGE OF REGULATION

In many applications, the full 10% regulation is not required. The range of regulation may be reduced by simply adjusting the tap-changer limit switches in the position indicator. In this way, increased current capacity is available and a smaller regulator can be used, with corresponding lower costs.

The increased current becomes available because the losses for the combination of reduced range of regulation and increased current capacity are not higher than the losses at full range of regulation and 100% load. Increased current in the series winding is offset by reduced current in the shunt winding. Also, at a reduced range of regulation, a part of the series winding is unused. This unused section is effective in dissipating the heat which results from the  $I^2R$  losses in the current-carrying part of the series winding.

### CAPACITOR BANKS IN THE SYSTEM

A capacitor bank on a distribution system may affect regulator settings. Capacitors generally correct for voltage back to the source; regulators correct for voltage on the load side. The following considerations can be made:

1. If the capacitor bank is on the source side of the regulator, the regulator sees the results of the capacitor bank; therefore, no changes are required in the control setting.
2. If the capacitor bank is connected beyond the load center, the regulator and load center are affected equally by the bank; therefore, no changes are required in the control setting.
3. The capacitor bank may be connected between the regulator and the load center.

NOTE: This application is not recommended.

In this case, the voltage level or compensation settings must be adjusted.

- A. For a fixed capacitor bank, increase the voltage level setting by the amount of voltage increase at the regulator over that at the load.
- B. For a switched bank, increase the voltage-level setting by one-half the actual increase produced by the capacitor bank.



Cooper Power Systems

Bulletin 77006 February 1993  
Supersedes October 1991  
File Ref: Catalog 225  
© 1993 Cooper Power Systems, Inc.

McGraw-Edison® and Auto-Booster® are registered trademarks of Cooper Industries.

**COOPER**

---

**Cooper Power Systems**

P.O. Box 2850, Pittsburgh, PA 15230