

Regulators

Control Replacement Assembly Installation Instructions Supplement

Service Information

S225-40-1

Supplement 1



Figure 1.
CL-6A Control Replacement Assembly.

Contents

Safety Information	2	Installation	4
Product Information	3	Making Connections to the CRA	4
Introduction	3	Connections to Siemens® Voltage Regulators	5
Acceptance and Initial Inspection	3	Connections to GE® Voltage Regulators	8
Handling and Storage	3	Connections to CPS Voltage Regulators	11
Standards	3	Control Setup	11
Description	3		



SAFETY FOR LIFE



Cooper Power Systems products meet or exceed all applicable industry standards relating to product safety. We actively promote safe practices in the use and maintenance of our products through our service literature, instructional training programs, and the continuous efforts of all Cooper Power Systems employees involved in product design, manufacture, marketing, and service.

We strongly urge that you always follow all locally approved safety procedures and safety instructions when working around high voltage lines and equipment and support our “Safety For Life” mission.

SAFETY INFORMATION

The instructions in this manual are not intended as a substitute for proper training or adequate experience in the safe operation of the equipment described. Only competent technicians, who are familiar with this equipment should install, operate, and service it.

A competent technician has these qualifications:

- *Is thoroughly familiar with these instructions.*
- *Is trained in industry-accepted high- and low-voltage safe operating practices and procedures.*
- *Is trained and authorized to energize, de-energize, clear, and ground power distribution equipment.*
- *Is trained in the care and use of protective equipment such as flash clothing, safety glasses, face shield, hard hat, rubber gloves, hotstick, etc.*

Following is important safety information. For safe installation and operation of this equipment, be sure to read and understand all cautions and warnings.

Safety Instructions

Following are general caution and warning statements that apply to this equipment. Additional statements, related to specific tasks and procedures, are located throughout the manual.

⚠ DANGER: Hazardous voltage. Contact with hazardous voltage will cause death or severe personal injury. Follow all locally approved safety procedures when working around high and low voltage lines and equipment.

G103.3

⚠ WARNING: Before installing, operating, maintaining, or testing this equipment, carefully read and understand the contents of this manual. Improper operation, handling or maintenance can result in death, severe personal injury, and equipment damage.

G101.0

⚠ WARNING: This equipment is not intended to protect human life. Follow all locally approved procedures and safety practices when installing or operating this equipment. Failure to comply can result in death, severe personal injury and equipment damage.

G102.1

⚠ WARNING: Power distribution equipment must be properly selected for the intended application. It must be installed and serviced by competent personnel who have been trained and understand proper safety procedures. These instructions are written for such personnel and are not a substitute for adequate training and experience in safety procedures. Failure to properly select, install or maintain power distribution equipment can result in death, severe personal injury, and equipment damage.

G122.2

Hazard Statement Definitions

This manual may contain four types of hazard statements:

⚠ DANGER: Indicates an imminently hazardous situation which, if not avoided, will result in death or serious injury.

⚠ WARNING: Indicates a potentially hazardous situation which, if not avoided, could result in death or serious injury.

⚠ CAUTION: Indicates a potentially hazardous situation which, if not avoided, may result in minor or moderate injury.

CAUTION: Indicates a potentially hazardous situation which, if not avoided, may result in equipment damage only.



PRODUCT INFORMATION

Introduction

Service Information S225-40-1 Supplement provides installation instructions for the CL-6A microprocessor-based voltage regulator control replacement assembly. This manual is intended to be used with *Service Information S225-40-1 McGraw-Edison® Voltage Regulator Control Replacement Assembly (CRA) Installation Instructions and Service Information*. Before installing and operating this control, carefully read and understand the contents of this manual.

Refer to *Service Information S225-11-1 Voltage Regulator CL-6 Series Control Installation, Operation, and Maintenance Instructions* for information on the CL-6 Series control.

Read This Manual First

Read and understand the contents of this manual and follow all locally approved procedures and safety practices before installing or operating this equipment. This control is used in conjunction with a voltage regulator. Read and understand the appropriate voltage regulator instruction manual before operating this control.

Additional Information

These instructions cannot cover all details or variations in the equipment, procedures, or process described nor provide directions for meeting every possible contingency during installation, operation, or maintenance. For additional information, please contact your Cooper Power Systems representative.

Acceptance and Initial Inspection

Each control replacement assembly is completely assembled, tested, and inspected at the factory. It is in good condition when accepted by the carrier for shipment. Upon receipt, inspect the shipping container for signs of damage. Unpack the control and inspect it thoroughly for damage incurred during shipment. If damage is discovered, file a claim with the carrier immediately.

Handling and Storage

Be careful during handling and storage of the control to minimize the possibility of damage. If the control is to be stored for any length of time prior to installation, provide a clean, dry storage area.

Standards

The Cooper Power Systems voltage regulator controls are designed and tested in accordance with:

IEEE Standard C57.15-1999™

IEEE Standard C57.95-1984™

Quality Standards

ISO 9001:2000 Certified Quality Management System

Description

The Cooper Power Systems Voltage Regulator Control Replacement Assembly (CRA) is designed to be used on single-phase regulators manufactured by Siemens and General Electric, as well as Cooper Power Systems type VR32 voltage regulators.

The CRA utilizes the control signals common to all regulators and incorporates circuitry on non-CPS regulators to allow the proper interface between Cooper Power Systems CL-series regulator controls and these regulators.

IMPORTANT: CRA Applications

The CRA was designed for used on General Electric and Siemens single-phase voltage regulators that utilize the following circuits:

- Control voltage or **load-side** voltage signal
- Motor raise and lower circuits
- Operations counter
- Common or ground
- CT current signal (optional)
- Source-side voltage signal (optional)
- Neutral light (optional)
- Drag hand reset (optional)

All of the signals listed are necessary for proper operation of the CRA unless otherwise noted as optional.

INSTALLATION

Making Connections to the CRA

The CRA connections are made to terminal board TB1, located on the back-panel; see Figure 2. A color-coded wiring decal clearly identifies connections; see Figure 3.

Connecting the lead to the terminal board requires using the tool supplied with the CRA assembly or an acceptable substitute; see Figure 4.

To use the tool, place the tool in the square hole next to the round hole where the proper wire is to be connected. Push the tool down, releasing the connector for the wire. Then, place the bare wire of the lead into the round hole, remove the tool from the square hole, and check the wire to make sure it is properly placed and is tight in the terminal board. Refer to Figure 5 for placement of the tool and the wire in the terminal board.



Figure 4.
Tool supplied for connecting leads.

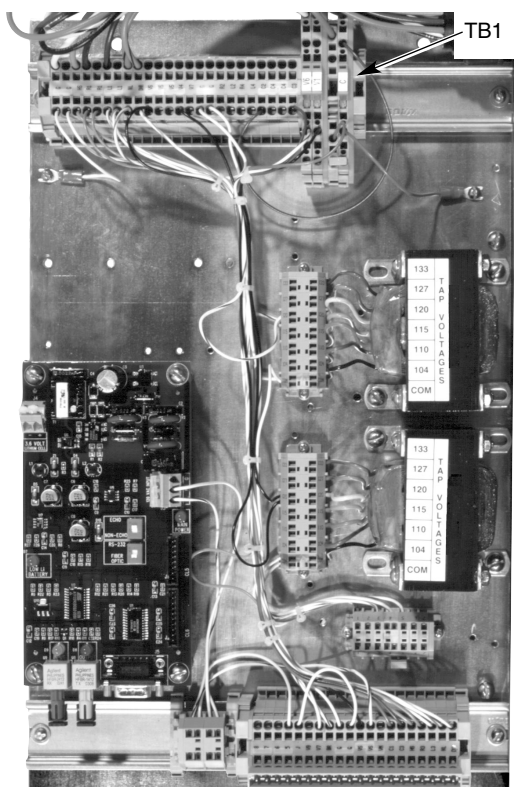

Figure 2.
CRA back panel.

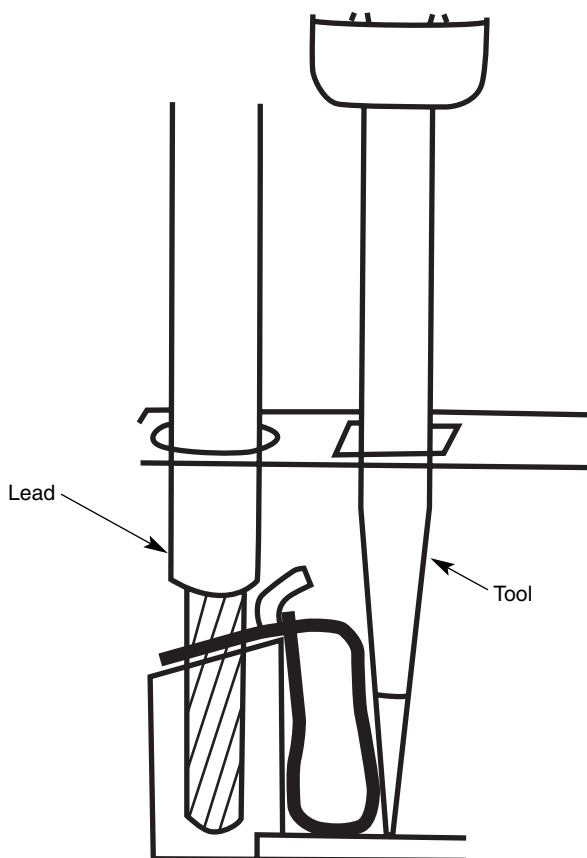

Figure 5.
Connecting leads to terminal board.

Label	G	R	L	OC	DHR	NL	HS	2	G	1	V2	V5	V1	V4	C2	C3	CAUTION: DO NOT OPEN CT CIRCUIT UNDER LOAD
Siemens	E	J	K	U10	U11	U12	CPS UNIT ONLY	SOURCE CONN.	E 26 or 10	SOURCE CONN.	REG. SOURCE FROM RCT 2		REG. LOAD FROM RCT 1		CT HIGH FOR ACCESSORY		
G. E.	10	27	28	30	29	31					VRCT 2	V5	VRCT 1	V4	C2	C3	
C. P. S.	G	RAISE	LOWER	OPCNTR	DHR	NEUT LT	HS	2	G	1							

Label	G E. UNIT ONLY			Knifedswitches - Top			Knifedswitches - Bottom		
	20	21	22	V6	V1	C	V6	V1	C
Siemens				U2	P2	C2			E1
G. E.	20	21	22	32	20,21 or 22	Black 20AWG			White 20AWG
C. P. S.	G E. UNIT ONLY			JBB-S4	JBB-S2	JBB-C2			JBB-C1

Figure 3.
Wiring identification decal.



Connections to Siemens® Voltage Regulators

 **DANGER:** Explosion Hazard. Voltage regulators are subject to high circulating current during bypass switching. Refer to *Service Information S225-11-1 Voltage Regulator CL-6 Series Control Installation, Operation, and Maintenance Instructions* for information on the CRA Control, and refer to the instruction manual supplied by the voltage regulator manufacturer for specific safety procedures for bypass switching. Failure to comply will result in severe personal injury or death.

VR-T214.0

 **WARNING:** Flashover Hazard. Opening the C.T. circuit under load will produce high voltages in the control box. Always bypass the regulator when installing the CRA to prevent opening the C.T. circuit while the regulator is under load. Failure to comply can result in severe personal injury or death.

VR-T215.0

The replacement procedure may be performed in the shop or the field. The regulator must be bypassed or removed from service prior to installing the CRA. Always bypass the regulator when installing the CRA in the field to prevent opening the CT circuit while the regulator is under load.

Note: The control cable may be an actual cable or a flexible conduit. For these instructions, it will be referred to as "control cable".

1. Bypass the regulator or remove it from service.
2. Open the existing control box and swing out the control front panel. Remove the front panel by disconnecting the jack plug and lifting the control off of its hinges.
3. If the incoming control cable leads are not marked or color-coded, place appropriate wire markers on the control cable leads or mark for reference later.
4. Disconnect the incoming control cable leads from the female jack plug located on the back of the control box.

If the tap-changer motor capacitor is located in the control box, disconnect the leads from the capacitor and remove the capacitor for reinstallation in the CPS box.

5. Remove the incoming control cable-retaining nut and remove the cable from the control box.

If the regulator is fitted with a non-flexible conduit housing the control leads, it will be necessary to modify or replace this conduit with a flexible conduit to allow interface to the Cooper Power Systems box.

6. Remove the cable compression connector (cable grip) from the control box.

7. Remove the nameplate from the old control box assembly and retain, with the hardware.
8. With an adjustable wrench (or appropriate socket wrench), remove and retain the bolts holding the control box on the regulator.
9. Remove the old control box assembly from the regulator.
10. Place the supplied universal bracket over the mounting bosses of the regulator and secure with bolts retained from the existing regulator.
11. Place the CRA control box on the universal bracket and secure it to the regulator with bolt, washer, lock-washer, and nut provided.
12. Attach the nameplate to the front of the CRA control box with retained hardware.

 **WARNING:** Hazardous Voltage. The control box must be solidly earth grounded. Failure to comply can result in severe personal injury and equipment damage.

VR-T216.0

13. Ground the control cabinet via the ground boss located on the side of the cabinet.
14. Examine the control cable. Allow approximately 12" of lead length to protrude past the end of the conduit nut. This will facilitate connection to the top terminal strip and knife switches located in the box.
15. Remove the cable grip nut and rubber cable grommet from the cable entrance of the control box.
16. Place the cable grip nut over the competitor's control cable. Select, from the two supplied rubber cable grommets, the one that fits the competitor's cable; place grommet onto the control cable.
17. Cut the terminals off of the customer's control cable conductors.

If the competitor's controls had a capacitor in the control cabinet, leave the capacitor connection terminals on the wires for the capacitor.

18. Strip the insulation back approximately 5/16 of an inch on each lead that is to connect to TB₁ and switches.
19. Insert the control cable into the control-box cable grip connector, seating the rubber grommet, and tighten the cable grip nut.

TABLE 1
CRA Connections to a Siemens Voltage Regulator

Cooper Labels	Siemens Connection
G	E
R	J
L	K
OC	U10
DHR	U11
NL	U12
G	E
V6	U2
V1	P2
C Switch Top	C2
C Switch Bottom	E1

20. V₆ connections and source-side signal.

Note: If there is only one RCT on the back panel, it is recommended to let the control calculate the source-side signal by making the necessary connections as described in step B.

A. If the regulator has a source-side control signal present and the back panel has two RCTs *OR* if the source-side supply is excitedly 120 V, the white/brown Number 23 lead can stay connected to the bottom of V₆ (as shown in Figure 7) and the internal source-side supply can be used for reverse power flow operation.

B. If there is no source-side control signal, *OR* only one RCT on the back panel, *OR* two RCTs on the back panel and you want to support control calculation of the source-side signal for reverse power flow operation, follow these wiring steps:

1. Connect the Siemens U2 lead, if present, to the top of the V₆ switch.
2. Using the supplied tool or a proper substitute, remove the white/brown Number 23 lead from the bottom section of V₆ and place, with the Number 17 lead, at the bottom of V₁.

21. Connect remaining leads per Table 1 and Figures 6 and 7. A decal (see Figure 3) is located in the bottom of the control box as a reference for wiring connections from the Siemens voltage regulator to the CRA terminal board and switches. The Siemens connections are labeled in Red and Cooper Identification is labeled in Black.

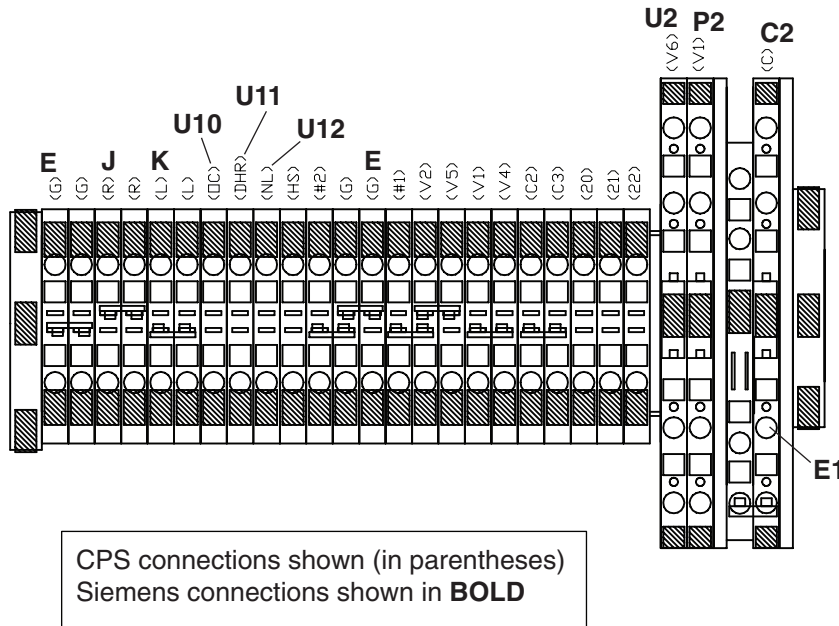

Figure 6.
TB₁ Siemens connections.

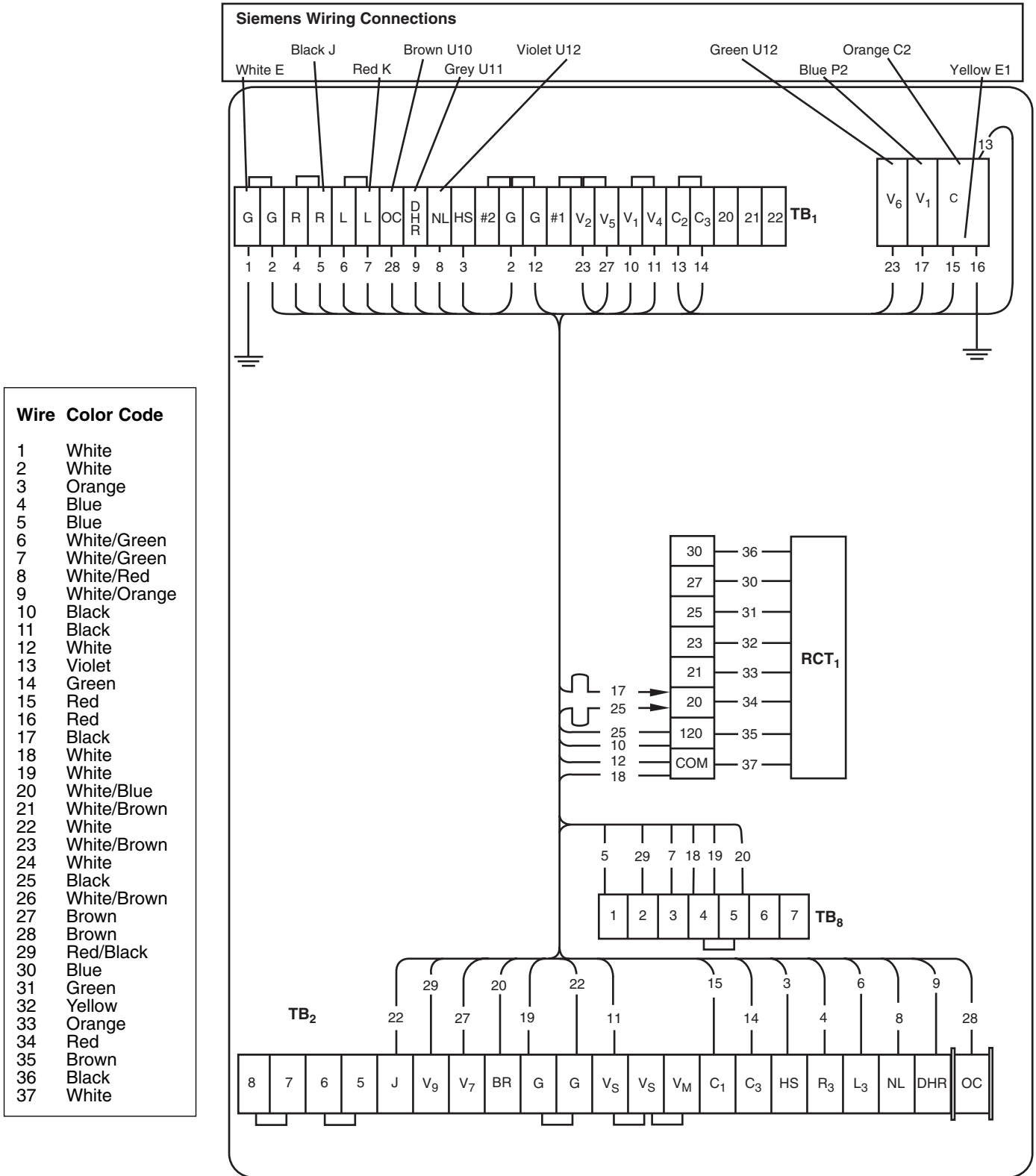

Figure 7.
CRA back panel wiring to Siemens voltage regulator.

Connections to GE® Voltage Regulators

DANGER: Explosion Hazard. Voltage regulators are subject to high circulating current during bypass switching. Refer to *Service Information S225-11-1 Voltage Regulator CL-6 Series Control Installation, Operation, and Maintenance Instructions* for information on the CRA Control, and refer to the instruction manual supplied by the voltage regulator manufacturer for specific safety procedures for bypass switching. Failure to comply will result in severe personal injury or death.

VR-T214.0

WARNING: Flashover Hazard. Opening the C.T. circuit under load will produce high voltages in the control box. Disconnect the GE position indicator plug assembly from the regulator prior to installing the CRA. Refer to the instruction manual provided by the voltage regulator manufacturer for specific safety procedures. Verify disconnect or bypass the regulator when installing the CRA to prevent opening the C.T. circuit while the regulator is under load. Failure to comply can result in severe personal injury or death.

VR-T217.0

The replacement procedure may be performed in the shop or the field.

1. Disconnect the GE "position indicator plug assembly" from the bottom of the position indicator to short-circuit the internal CT.

IMPORTANT:

GE regulators incorporate a control-cable disconnect device. The device has an internal CT short-circuiting scheme that shorts the internal current transformer circuit when the control cable is disconnected. If there is doubt as to whether or not the CT shorting device is functional, it is recommended that the regulator be bypassed or removed from service to remove load current from the regulator which would render the CT circuit safe to open during installation of the CRA.

Refer to the appropriate GE regulator instruction manual for specific information.

2. Open the existing control box and note the incoming control cable leads and associated color-coding. If the incoming control cable leads are not marked or color coded, place appropriate wire markers on the control cable leads or mark for reference later.
3. Disconnect the incoming control cable leads from the terminal strip(s) located on the back of the GE control box.

If the tap-changer motor is located in the control box, disconnect the leads from the capacitor and remove the capacitor for reinstallation in the CPS box.

4. Remove the incoming control cable-retaining nut and remove the cable from the control box.

If the regulator is fitted with a non-flexible conduit housing the control leads, it will be necessary to modify or replace this conduit with a flexible conduit to allow interface to the Cooper Power Systems box.

5. Remove the cable compression connector (cable grip) from the control box.
6. Remove the nameplate from the old control box assembly and retain, with the hardware.
7. With an adjustable wrench (or appropriate socket wrench), remove and retain the bolts holding the control box on the regulator.
8. Remove the old control box assembly from the regulator.
9. Place the supplied universal bracket over the mounting bosses of the regulator and secure with retained bolts from the existing regulator.
10. Place the CRA control box on the universal bracket and secure it to the regulator with bolt, washer, lock-washer and nut provided.
11. Attach the nameplate to the front of the CRA control box with retained hardware.

WARNING: Hazardous Voltage. The control box must be solidly earth grounded. Failure to comply can result in severe personal injury and equipment damage.

VR-T216.0

12. Ground the control cabinet via the ground boss located on the side of the cabinet.
13. Examine the control cable. Allow approximately 12" of lead length to protrude past the end of the conduit nut. This will facilitate connection to the top terminal strip and knife switches located in the box.
14. Remove the cable grip nut and rubber cable grommet from the cable entrance of the CRA control box.
15. Place the cable grip nut over the competitor's control cable. Select, from the two supplied rubber cable grommets, the one that fits the competitor's cable; place grommet onto the control cable.
16. Cut the terminals off of the customer's control cable conductors.

If the competitor's controls had a capacitor in the control cabinet, leave the capacitor connection terminals on the wires for the capacitor.

17. Strip the insulation back approximately 5/16 of an inch on each lead that is to connect to TB₁ and switches.
18. Insert the control cable into the control-box cable grip connector, seating the rubber grommet, and tighten the cable grip nut.



19. V₆ connections and source-side signal.

Note: If there is only one RCT on the back panel, it is recommended to let the control calculate the source-side signal by making the necessary connections as described in step 16 B.

A. If the regulator has a source-side control signal present and the back panel has two RCTs *OR* if the source-side supply is excitedly 120 V, the white/brown Number 23 lead can stay connected to the bottom of V₆ (as shown in Figure 8) and the internal source-side supply can be used for reverse power flow operation.

B. If there is no source-side control signal, *OR* only one RCT on the back panel, *OR* two RCTs on the back panel and you want to support control calculation of the source-side signal for reverse power flow operation, follow these wiring steps:

1. Connect the GE 32 lead, if present, to the top of the V₆ switch.
2. Using the supplied tool or a proper substitute, remove the white/brown Number 23 lead from the bottom section of V₆ and place, with the Number 17 lead, at the bottom of V₁.

20. Connect remaining leads per Table 2 and Figures 8 and 9. A decal (see Figure 3) is located in the bottom of the control box as a reference for wiring connections from the GE voltage regulator to the CRA terminal board and switches. The GE connections are labeled in Green and Cooper Identification is in Black.

Note: If the color codes does not match, check Table 2. There have been several different color code identifications use by GE over the years. If ID label numbers are used, they should agree on all color code possibilities use by GE.

21. To make the connection to the top of V₁ use the black 20 AWG wire supplied in the bottom of the CRA control box. Using the tool supplied with the CRA, connect the black wire to the top of the V₁ switch. Per the GE nameplate and the system voltage desired, connect the other end of the black wire to the bottom of TB₁ 20, or 21, or 22.

TABLE 2
CRA Connections to a GE Voltage Regulator

CPS Labels	Old GE Connection	Connections Supplied with GE SM-3 Controls
G	White 10 (16 AWG)	White
R	Red 27	Yellow/Red
L	Green 28	Black/Red
OC	Red/Black 30	Orange/Black
DHR	Red/White 29	Blue/Black
NL	Blue/White 31	Orange/Red
G	Green/Black 26	Brown
G	Blue/Black 10	-
20	Orange/Black 20	Black
21	Orange 21	Red
22	Blue 22	Orange
V6	Black 32 (16 AWG)	Blue
V1	20, or 21, or 22	Black or Red or Orange
Top C	Black (20 AWG)	Blue/Red
Bottom C	White (20 AWG)	Red/Blue
CPS Labels	GE Label IDs	Newer GE Connection Color Codes
G	10	Green & Yellow/Black 10
R	27	Yellow/Red
L	28	Black/Blue
OC	30	Orange/Black
DHR	29	Blue/Black
NL	31	Orange/Red
G	26 or 10	Brown, Yellow, White
G	-	White
20	20	Black & Black/Red
21	21	Red & Red/Black
22	22	Orange & Brown/Red
V6	32	Brown/Black & Blue
V1	20, or 31, or 22	Bottom of 20, or 21, or 22
Top C	-	Blue/Red
Bottom C	-	Red/Blue

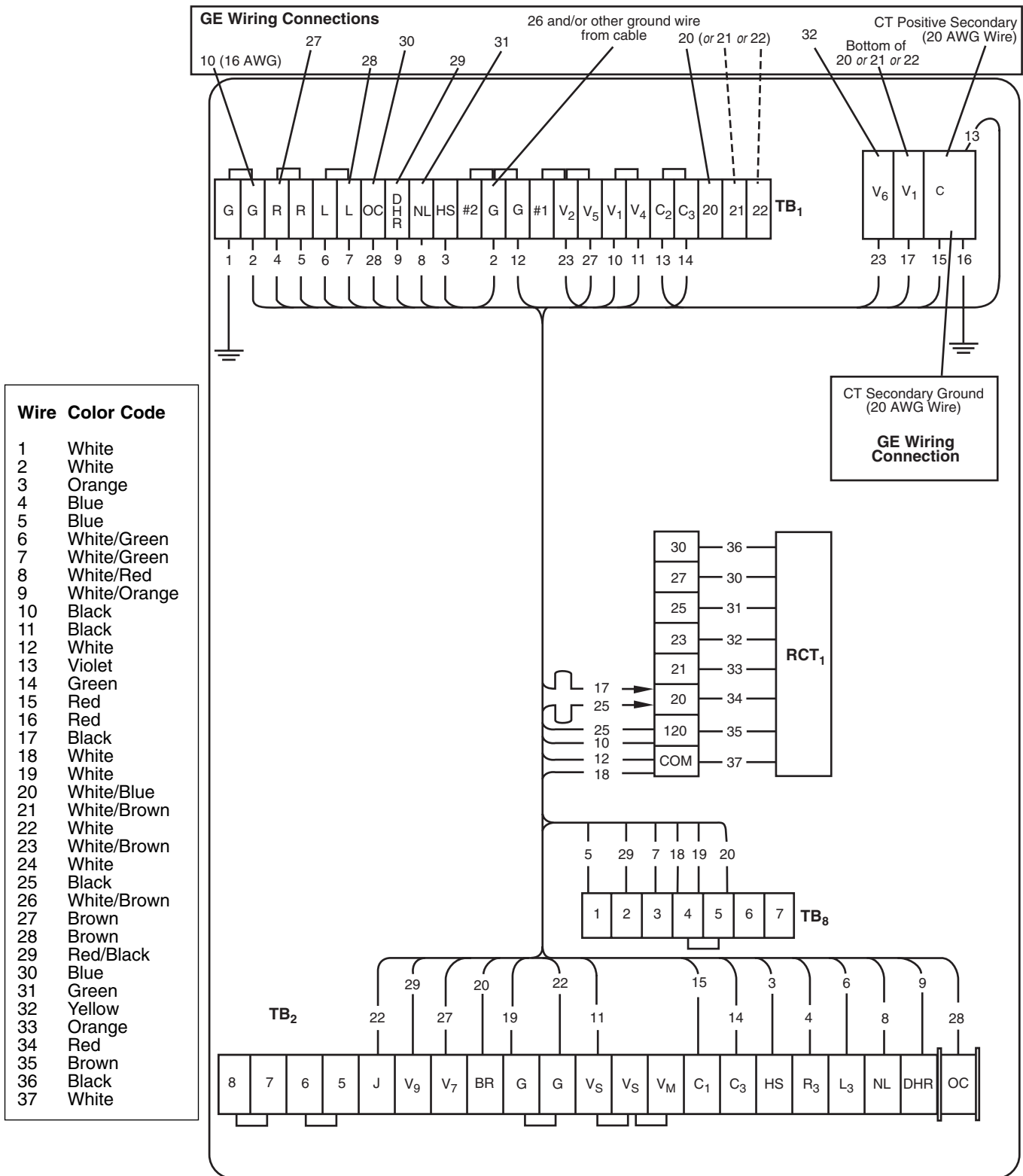

Note: If the color codes does not match, check Table 2, matching with lead number identifications. There have been several different color code identifications use by GE over the years. If ID label numbers are used, they should agree on all color code possibilities used by GE.

Figure 8.
CRA back panel wiring to GE voltage regulator.

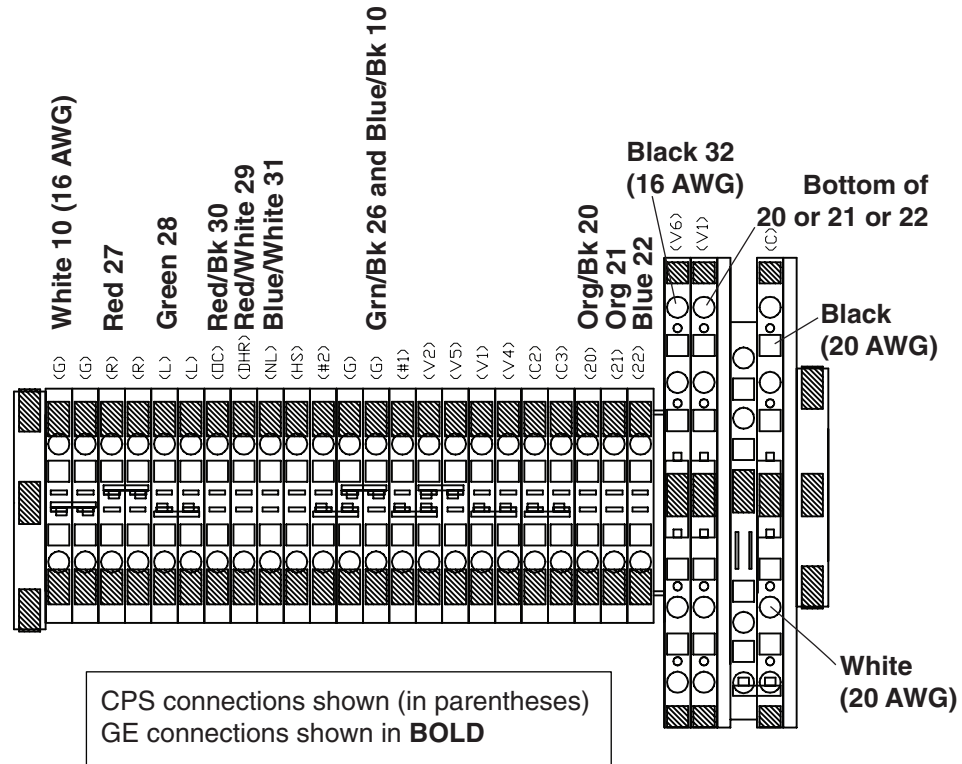

Figure 9.
TB₁ GE connections.

Connections to CPS Voltage Regulators

When using the CRA on a McGraw-Edison® or Cooper Power Systems voltage regulator, refer to *Service Information S225-40-1* for information on Control Replacement Assembly, to *Service Information S225-11-1* for information on the CL-6 series voltage regulator control, and to *Service Information S225-10-10* for information on a McGraw-Edison® or CPS voltage regulator. Understand the contents of the manuals and follow all safety procedures.

For wiring connections to the CL-6 CRA, refer to Figure 10.

If the regulator has a source-side control signal present and there is only one (RCT) ratio-correction transformer, connect the white/black wire to the top of the V6 switch. Move the white/brown number 23 lead from the bottom of V6 and connect to the bottom of V1.

CONTROL SETUP

Refer to *Service Information S225-40-1*, *Service Information S225-11-1*, and, when using the CRA on a McGraw-Edison® or Cooper Power Systems voltage regulator, *Service Information S225-10-10*, for information on operational checks, control calibration, and ratio correction to confirm correct functioning of the CRA. Verify all control settings.

Contact your local Cooper Power Systems representative with any questions regarding the correct installation and operation of the CRA voltage regulator control.

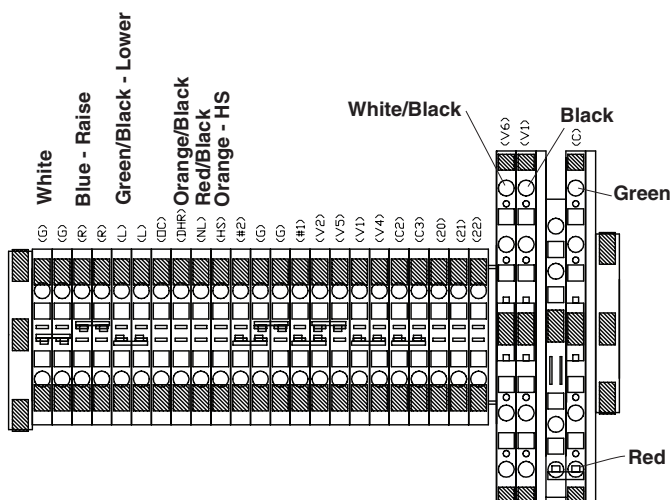

Figure 10.
TB₁ CPS connections.



©2005 Cooper Power Systems or its affiliates.
McGraw-Edison® is a registered trademark of Cooper Power Systems or its affiliates.
IEEE Standard C57.15-1999™ and IEEE Standard C57.95-1984™ are trademarks of the Institute of Electrical and Electronics Engineers, Inc.
GE® is a registered trademark of General Electric Company.
Siemens® is a registered trademark of Siemens Aktiengesellschaft.

**COOPER** Power Systems

1045 Hickory Street
Pewaukee, WI 53072 USA
www.cooperpower.com