

Vacuum-Break Switches

Type VCS-3
 Three-Phase; Vacuum-Break Capacitor Switch
 Installation and Operation Instructions

Service Information
S260-62-1

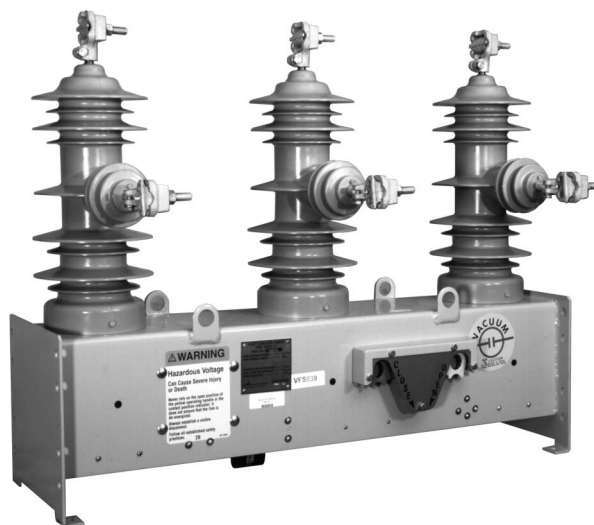

Figure 1.
 Kyle® Type VCS-3 Three-Phase Vacuum-Break Capacitor Switch.

010032KM

Contents

Safety Information	2	Accessories	10
Hazard Statement Definitions	2	Terminals	10
Safety Instructions	2	Pole-Mounting Hanger	10
Product Information	3	Arrester-Mounting Frames	11
Introduction	3	Substation-Mounting Frame	12
Acceptance and Initial Inspection	3	Three-Stage Auxiliary Switch	13
Handling and Storage	3	Service Information	14
Description of Operation	3	Service Requirements	14
Ratings and Specifications	4	Frequency of Inspection	14
Check Switch Ratings Prior to Installation	4	High-Potential Withstand Testing	14
Dimensions and Mass	5	Inspection of VCS-3 Module	15
Testing Operation	6	Factory-Authorized Service Centers	15
Installation Procedure	7		
Operation	8		
Electrical Operation	8		
Hotstick Operation	8		



SAFETY FOR LIFE



Cooper Power Systems products meet or exceed all applicable industry standards relating to product safety. We actively promote safe practices in the use and maintenance of our products through our service literature, instructional training programs, and the continuous efforts of all Cooper Power Systems employees involved in product design, manufacture, marketing, and service.

We strongly urge that you always follow all locally approved safety procedures and safety instructions when working around high voltage lines and equipment and support our “Safety For Life” mission.

SAFETY INFORMATION

The instructions in this manual are not intended as a substitute for proper training or adequate experience in the safe operation of the equipment described. Only competent technicians, who are familiar with this equipment should install, operate, and service it.

A competent technician has these qualifications:

- *Is thoroughly familiar with these instructions.*
- *Is trained in industry-accepted high- and low-voltage safe operating practices and procedures.*
- *Is trained and authorized to energize, de-energize, clear, and ground power distribution equipment.*
- *Is trained in the care and use of protective equipment such as flash clothing, safety glasses, face shield, hard hat, rubber gloves, hotstick, etc.*

Following is important safety information. For safe installation and operation of this equipment, be sure to read and understand all cautions and warnings.

Safety Instructions

Following are general caution and warning statements that apply to this equipment. Additional statements, related to specific tasks and procedures, are located throughout the manual.

 **DANGER:** Hazardous voltage. Contact with hazardous voltage will cause death or severe personal injury. Follow all locally approved safety procedures when working around high voltage lines and equipment. G103.3

 **WARNING:** Before installing, operating, maintaining, or testing this equipment, carefully read and understand the contents of this manual. Improper operation, handling or maintenance can result in death, severe personal injury, and equipment damage. G101.0

 **WARNING:** This equipment is not intended to protect human life. Follow all locally approved procedures and safety practices when installing or operating this equipment. Failure to comply may result in death, severe personal injury and equipment damage. G102.1

 **WARNING:** Power distribution equipment must be properly selected for the intended application. It must be installed and serviced by competent personnel who have been trained and understand proper safety procedures. These instructions are written for such personnel and are not a substitute for adequate training and experience in safety procedures. Failure to properly select, install or maintain power distribution equipment can result in death, severe personal injury, and equipment damage. G122.2

Hazard Statement Definitions

This manual may contain four types of hazard statements:

 **DANGER:** Indicates an imminently hazardous situation which, if not avoided, will result in death or serious injury.

 **WARNING:** Indicates a potentially hazardous situation which, if not avoided, could result in death or serious injury.

 **CAUTION:** Indicates a potentially hazardous situation which, if not avoided, may result in minor or moderate injury.

CAUTION: Indicates a potentially hazardous situation which, if not avoided, may result in equipment damage only.

PRODUCT INFORMATION

Introduction

Service Information S260-62-1 provides installation, operation, and maintenance instructions for the Kyle Type VCS-3 Switch.

Read This Manual First

Read and understand the contents of this manual and follow all locally approved procedures and safety practices before installing or operating this equipment.

Additional Information

These instructions cannot cover all details or variations in the equipment, procedures, or process described, nor provide directions for meeting every possible contingency during installation, operation, or maintenance. When additional information is desired to satisfy a problem not covered sufficiently for the user's purpose, please contact your Cooper Power Systems representative.

Acceptance and Initial Inspection

Each switch is completely assembled, tested, and inspected at the factory. It is in good condition when accepted by the carrier for shipment.

Upon receipt, inspect the shipping container for signs of damage. Unpack the switch and inspect it thoroughly for damage incurred during shipment. If damage is discovered, file a claim with the carrier immediately.

Surface blemishes may occur on some units. Such blemishes are benign and cosmetic, and therefore, will not adversely affect the performance of the switch.

Handling and Storage

Be careful during handling and storage of the switch to minimize the possibility of damage. If the switch is to be stored for any length of time prior to installation, provide a clean, dry storage area.

Standards

Kyle switches are designed and tested in accordance with IEC-265-1 and ANSI C37.66, where applicable.

Quality Standards

The Quality System at the Cooper Power Systems, Kyle Distribution Switchgear plant is certified to the following standards:

- ISO 9001
- CAN/CSA ISO 9001
- BS EN ISO 9001
- ANSI/ASQC Q9001

Description of Operation

The Kyle Type VCS-3 three-phase vacuum-interrupting switch provides switching capability for three-phase grounded capacitor banks in sizes up to 7200 kvar at 14.4 kV and up to 12,000 kvar at 24.9 kV. The mechanism utilizes a magnetic actuator for opening and closing functions. Two fixed 10 Watt heaters prevent condensation from forming in the mechanism housing. The solid polymer insulation system does not rely on gaseous or liquid dielectric. The VCS-3 switch is highly resistant to ozone, oxygen, moisture, contamination and ultraviolet light. The VCS-3 switch has three, solid-polymer interrupter modules and is suitable for operation through a temperature range of -40°C to +55°C. This results in an environmentally-safe switch for general purpose, capacitor, and distribution switching applications.

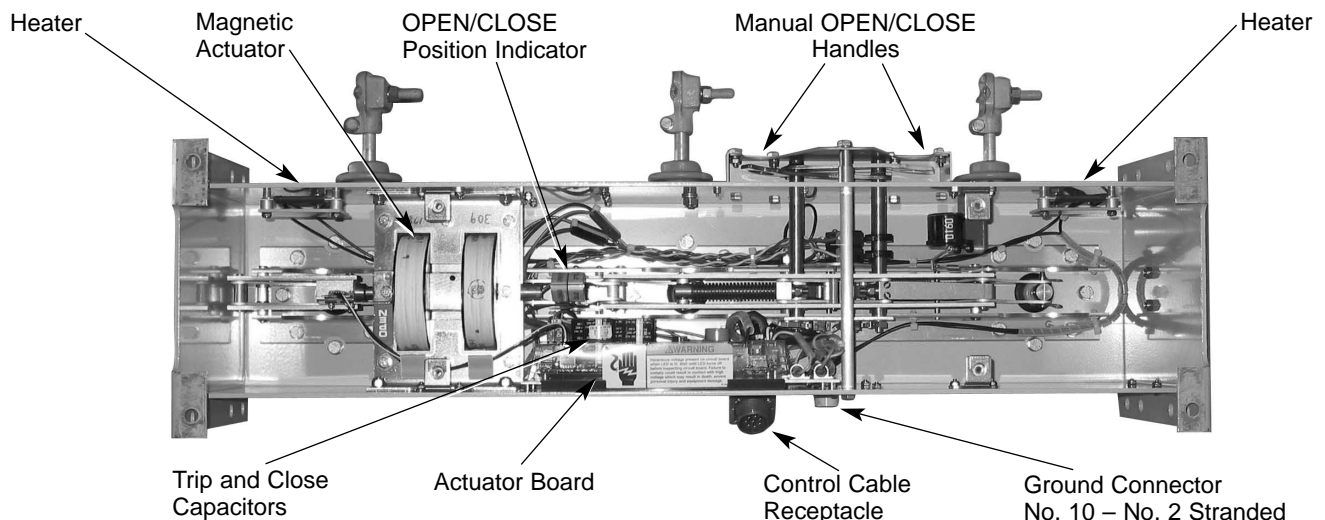

Figure 2.
Type VCS-3 Switch mechanism (view from bottom of switch with bottom cover removed).

010033KM

RATINGS AND SPECIFICATIONS

Check Switch Ratings Prior To Installation

The switch must be applied within its specified ratings. Check data plate ratings and compare with the system characteristics at the point of application, prior to installation. Tables 1 through 5 list the ratings and specifications for the Type VCS-3 switch.

TABLE 1
Voltage Ratings (kV)

Description	VCS-3-15	VCS-3-27
Maximum Voltage	15.5 kV	29.2 kV
Rated Basic Impulse Voltage	110.0 kV	125.0 kV
Radio Noise Limit (microvolts)	100 @ 9.4 kV	100 @ 17.7 kV
Power Frequency Withstand (dry)	50.0 kV	60.0 kV
Power Frequency Withstand (wet)	45.0 kV	50.0 kV

TABLE 2
Current Ratings (Amperes)

Description	VCS-3-15	VCS-3-27
Rated Continuous Current	200 A / 400 A	200 A / 400 A
Rated Capacitor Current Switching	200 A / 400 A	200 A / 400 A
Short Circuit Current, 3-Second Symmetrical	12.5 kA	12.5 kA
Making Current, Asymmetrical Peak	31.0 kA	31.0 kA
Making Current, Asymmetrical RMS	20.0 kA	20.0 kA

TABLE 3
Mechanical Ratings

Description	VCS-3-15	VCS-3-27
Mechanical Operations without Maintenance (opening/closing operations)	10,000	10,000

TABLE 4
Electrical Specifications

Description	VCS-3-15	VCS-3-27	VCS-3-38	VCS-3-50
Operating Voltage, nominal.	120 Vac	240 Vac	48 Vdc	125 Vdc
Operating Voltage Range	90–135 Vac	190–265 Vac	46–56 Vdc	100–140 Vdc
Nominal Close Time	60 ms	60 ms	60 ms	60 ms
Nominal Open Time	60 ms	60 ms	60 ms	60 ms
Power Requirements (including heaters).	150 Watt	150 Watt	150 Watt	125 Watt

DIMENSIONS AND MASS

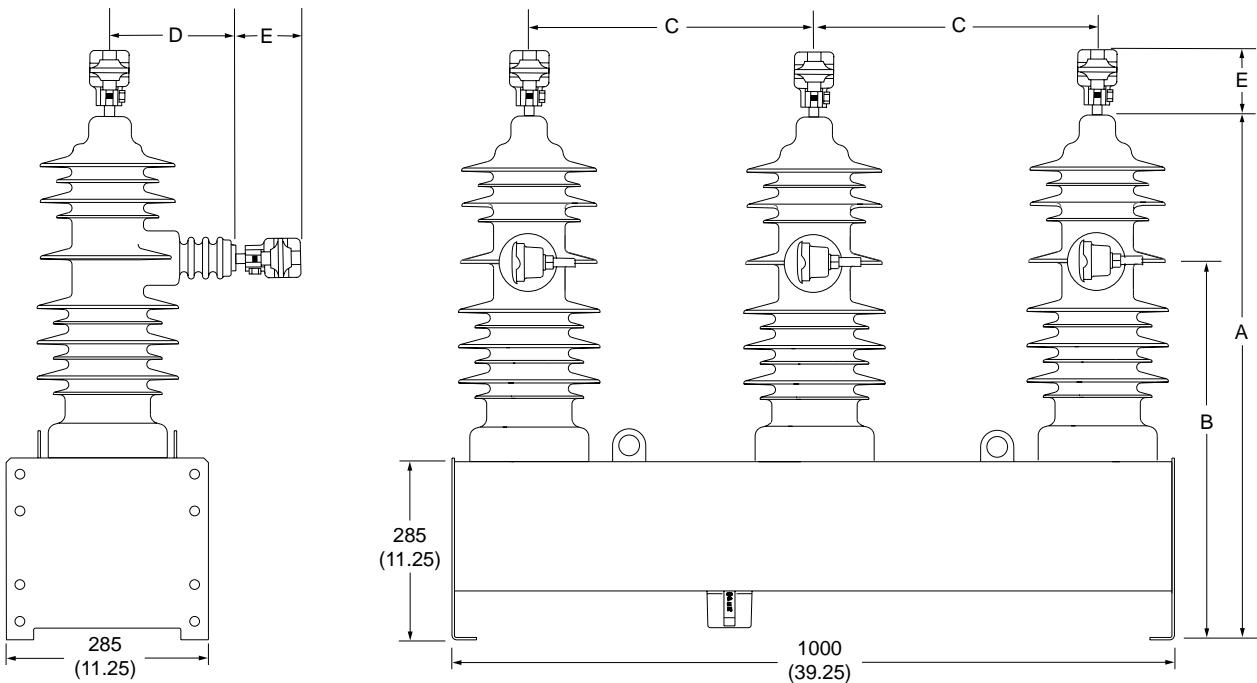

NOTE: All dimensions are mm (inches). Dimensions shown are approximate.

	A	B	C	D
VCS-3-15	730 (28.75)	508 (20)	394 (15.5)	215 (8.5)
VCS-3-27	787 (31)	572 (22.5)	394 (15.5)	215 (8.5)

Terminal Options	E
Eyebolt , 1/0 - 500 mcm Cable Range (630 A maximum)	80 (3.25)
Flat Pad , 2-hole (630 A maximum)	114 (4.5)
Flat Pad , 4-hole (800 A maximum)	121 (4.75)
Stud Type , 1.125 - 12 threads (800 A maximum)	82 (3.25)

Creepage Distances

Description	VCS-3-15	VCS-3-27
Terminal to terminal*	675 (26.50)	675 (26.5)
Terminal to ground/earth	670 (26.25)	834 (32.75)

*On the same phase.

Figure 3.
Type VCS-3 switch dimensions.

TABLE 5
Type VCS-3 Switch Weight

Description	VCS-3-15	VCS-3-27
VCS-3 switch - kilograms (pounds)	70 (155)	73 (160)

TESTING OPERATION

WARNING: This equipment is not intended to protect human life. Follow all locally approved procedures and safety practices when installing or operating this equipment. Failure to comply can result in death, severe personal injury and equipment damage.

G102.1

WARNING: Hazardous voltage. Always use a hotstick when working with this equipment. Failure to do so could result in contact with high voltage, which will cause death or severe personal injury.

G108.1

1. **Check the nameplate ratings.** Make sure the ratings and settings on the switch nameplate are correct for the planned installation.
2. **Test electrical open and close operation.** Close and open the switch contacts using an electronic control or power supply. Confirm that the contacts have closed and opened by
 - A. The OPEN/CLOSE position indicator, or
 - B. By a continuity check between the switch terminals.
3. **Test manual open and close.** Using a hotstick, pull the yellow manual OPEN handle to open the switch contacts. Confirm that the contacts are open by
 - A. The OPEN/CLOSE position indicator, or
 - B. By a continuity check between the switch terminals.

To close the switch contacts

 - C. Raise the yellow OPEN handle.
 - D. Pull the red manual CLOSE handle.

Moving the Switch

The Type VCS-3 switch is shipped bolted to a pallet. When moving with a fork truck/lift, the switch must remain bolted on the pallet to avoid damage to the OPEN/CLOSE indicator.

Lifting the Switch

Follow all approved safety practices when making hitches and lifting the equipment. Lift the unit smoothly and do not allow the unit to shift.

This switch has four lifting lugs - all four lugs must be used when lifting.

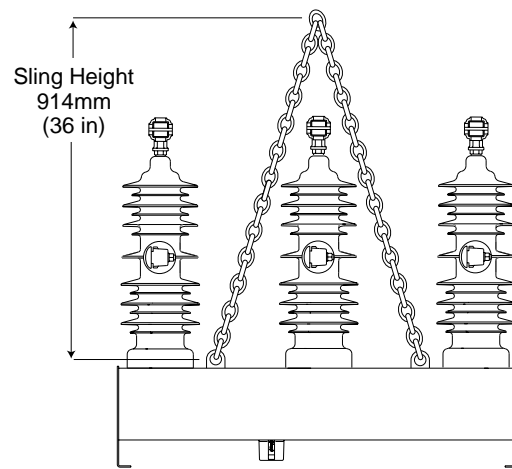
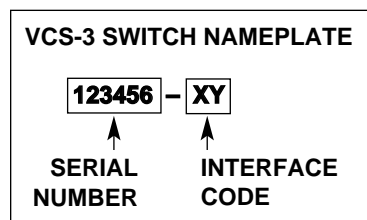

Figure 4.
Lifting instructions for the Type VCS-3 switch.

TABLE 6
Nameplate Stamping



OPTION	X	Y
Type A Mechanism	A	—
120 Vac input power	—	H
240 Vac input power	—	J
48 Vdc input power	—	A
Type B Mechanism	B	—
125 Vdc input power	—	D

INSTALLATION PROCEDURE

WARNING: This equipment is not intended to protect human life. Follow all locally approved procedures and safety practices when installing or operating this equipment. Failure to comply can result in death, severe personal injury and equipment damage.

G102.1

When installing the switch, refer to the applicable switch mounting frame instructions. Installation instructions are included with the mounting frame.

1. Check the nameplate ratings. Make sure the ratings and settings on the switch data plates are correct for the planned installation.
2. Install the switch. Kyle mounting frames should always be used. See Figure 4 for lifting instructions.

CAUTION: Follow all locally approved safety practices when lifting and mounting the equipment. Use the lifting lugs provided. Lift the unit smoothly and do not allow the unit to shift. Improper lifting can result in equipment damage.

G106.2

CAUTION: Personal Injury. Bushings have sharp edges. Wear protective gloves when handling the unit. Failure to do so can result in cuts and abrasions.

T258.0

WARNING: Hazardous voltage. Solidly ground all equipment. Failure to comply can result in death, severe personal injury, and equipment damage.

T223.2

3. Ground the switch. Make the ground connection to the ground connector. The ground connector is located on the back of the mechanism housing. The ground clamp accepts No. 10 through No. 2 stranded cables.

CAUTION: Equipment Damage. Do not adjust or rotate bushing terminals. The bushing terminals are factory-calibrated to meet the continuous current requirement of the switchgear. Adjusting or rotating the bushing terminals can damage the encapsulated interrupter resulting in equipment damage or personal injury.

T270.0

4. Connect high voltage lines to switch bushing terminals. Refer to Figure 5 for terminal identification.
5. Connect the 8-pin capacitor control cable to the appropriate receptacle on the back of the switch.
6. If applicable, connect the 3-stage auxiliary switch 14-pin cable to the appropriate receptacle on the back of the switch.

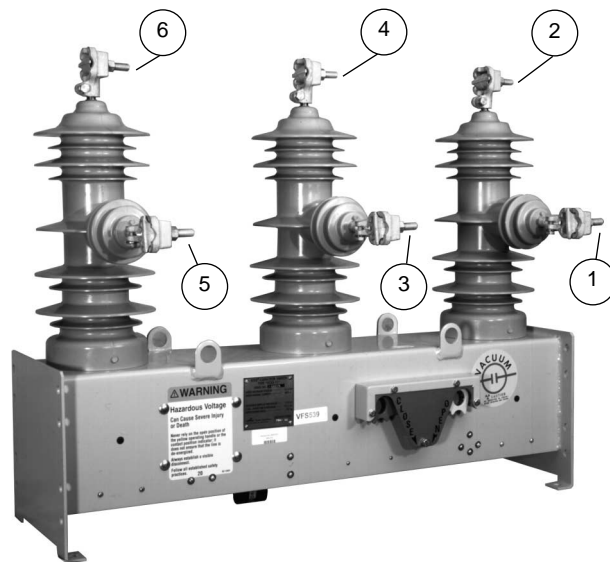



Figure 5.
Terminal identification of Type VCS-3 switch.

OPERATION

 **WARNING:** This equipment is not intended to protect human life. Follow all locally approved procedures and safety practices when installing or operating this equipment. Failure to comply can result in death, severe personal injury and equipment damage.

G102.1

 **WARNING:** Hazardous voltage. Do not rely on the open position of the yellow manual OPEN handle or the contact position indicator; it does not ensure that the line has been de-energized. Always establish a visible disconnect. Failure to follow proper safety practices can result in contact with high voltage, which will cause death or severe personal injury.

G130.0

Electrical Operation

With the appropriate voltage applied (see Table 4) to Pin "A", with Pin "B" as ground, the switch may be opened or closed electrically by making momentary contact by applying control voltage to either "C" or "D" for a minimum 300 ms. The switch has an 8-pin receptacle (see Figure 6) which provides switch status contacts, close control signal, open control signal, and power for the heater and the trip and close capacitors.

OPEN/CLOSE Position Indicator

The OPEN/CLOSE contact position indicator consists of a red CLOSED and a green OPEN indicator located on the bottom of the mechanism housing.

IMPORTANT: If the yellow manual OPEN handle remains in the down position, the switch cannot be closed electrically.

Hotstick Operation

 **WARNING:** Hazardous Voltage. Always use a hotstick when working with this equipment. Failure to do so could result in contact with high voltage, which will cause death or severe personal injury.

G108.1

The switch may be opened and closed manually by using a hotstick. To open, pull down the yellow manual OPEN handle located on the side of the switch (see Figure 2). To close the switch, first, push the yellow manual OPEN handle up. Then, pull down the red manual CLOSE handle located on the side of the switch (see Figure 2).

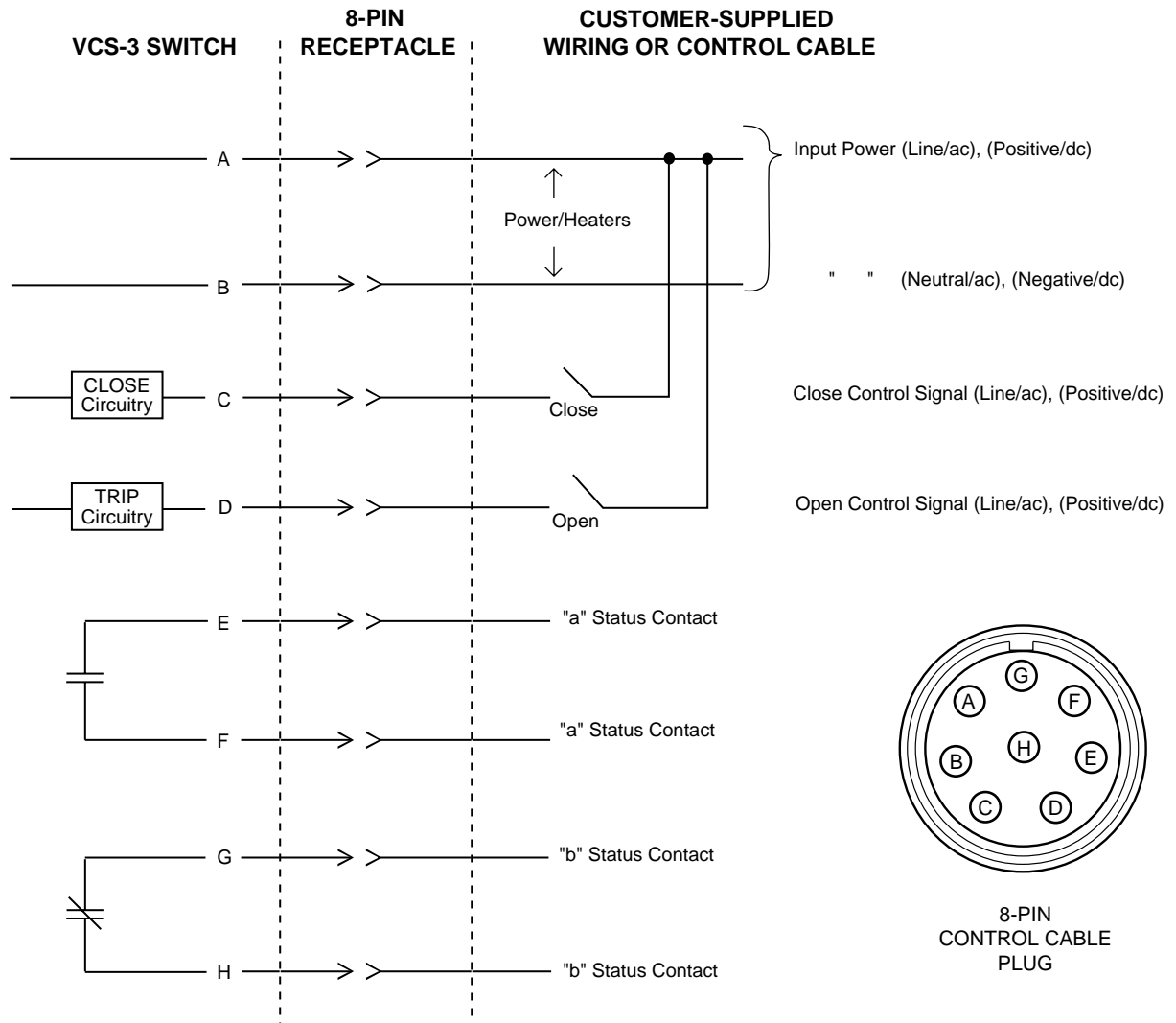

Figure 6.
VCS-3 Switch 8-pin receptacle diagram shown with switch in the open position.

ACCESSORIES

Terminals

The standard terminal is an eyebolt, 1/0 - 500 mcm (630 A). The 2-hole and 4-hole flat pad terminals, and stud type terminals are available as an accessory (see Figure 3).

Pole-Mounting Hanger

A simple pole-mounting hanger (see Figure 7), that bolts directly to the switch frame, provides a strong, clean, and uncluttered pole-mounting installation.

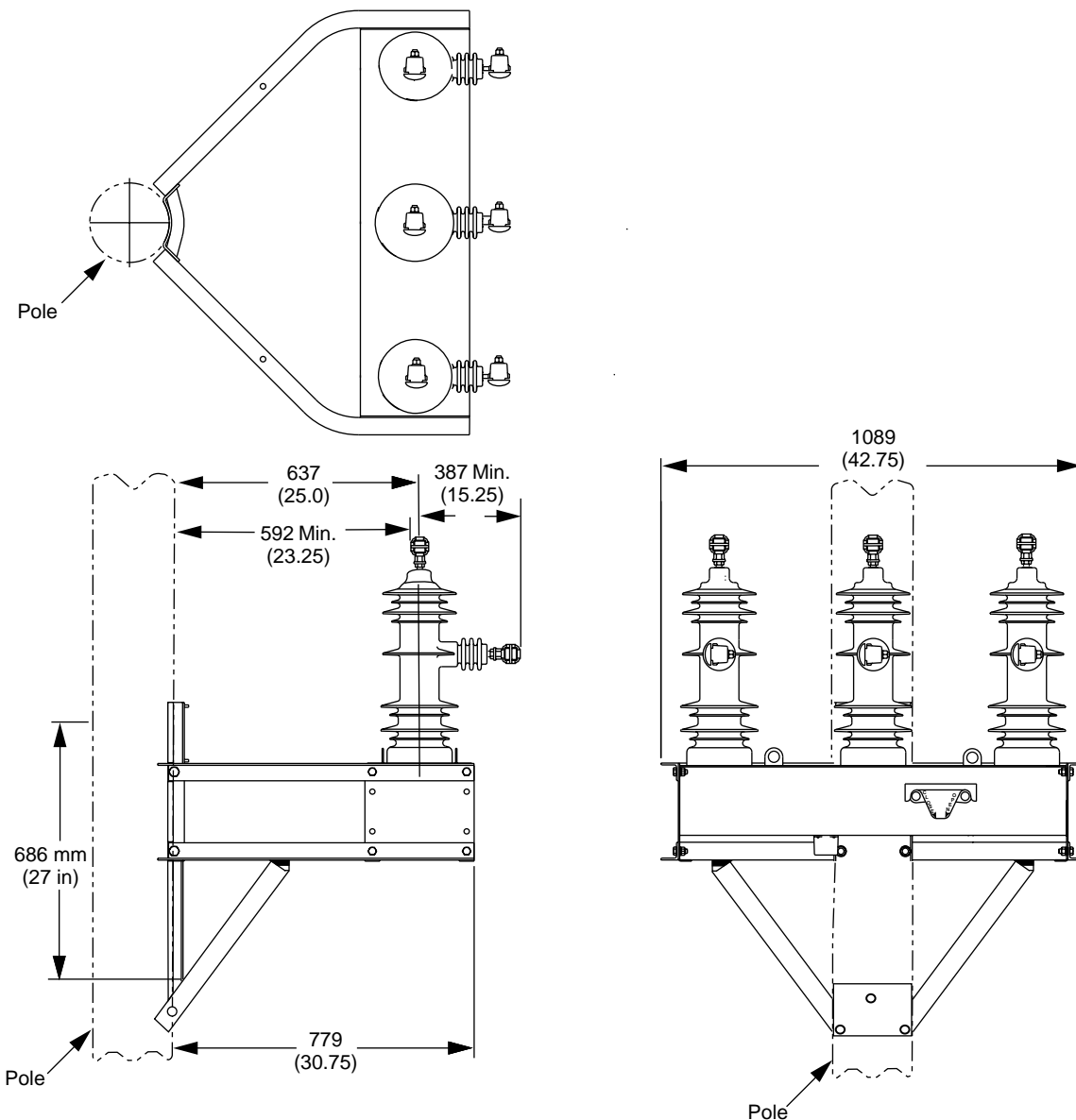

NOTE: All dimensions are mm (inches).
Dimensions shown are approximate.

Figure 7.
Dimensions of Type VCS-3 switch with pole-mounting hanger accessory.

Substation-Mounting Frame

A substation-mounting frame accessory (see Figure 9) is available for substation-mounting applications.

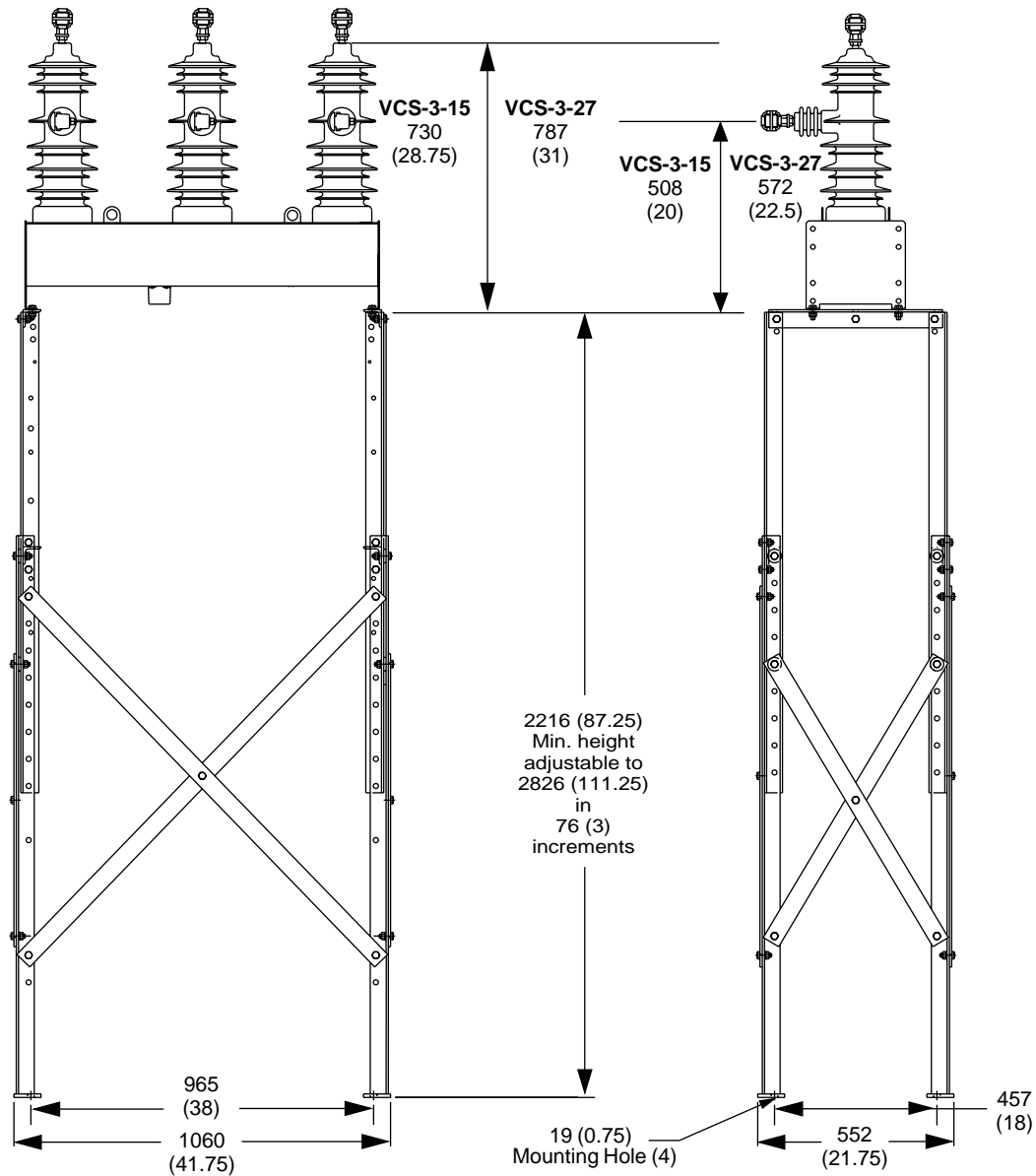

NOTE: All dimensions are mm (inches).
Dimensions shown are approximate.

Figure 9.
Dimensions of Type VCS-3 switch with substation-mounting frame accessory.

Three-Stage Auxiliary Switch

A three-stage auxiliary switch accessory provides three "a" and three "b" status contacts. These contacts are accessible through a 14-pin receptacle provided with the accessory. The mating plug and cable are available separately. See Figure 10.

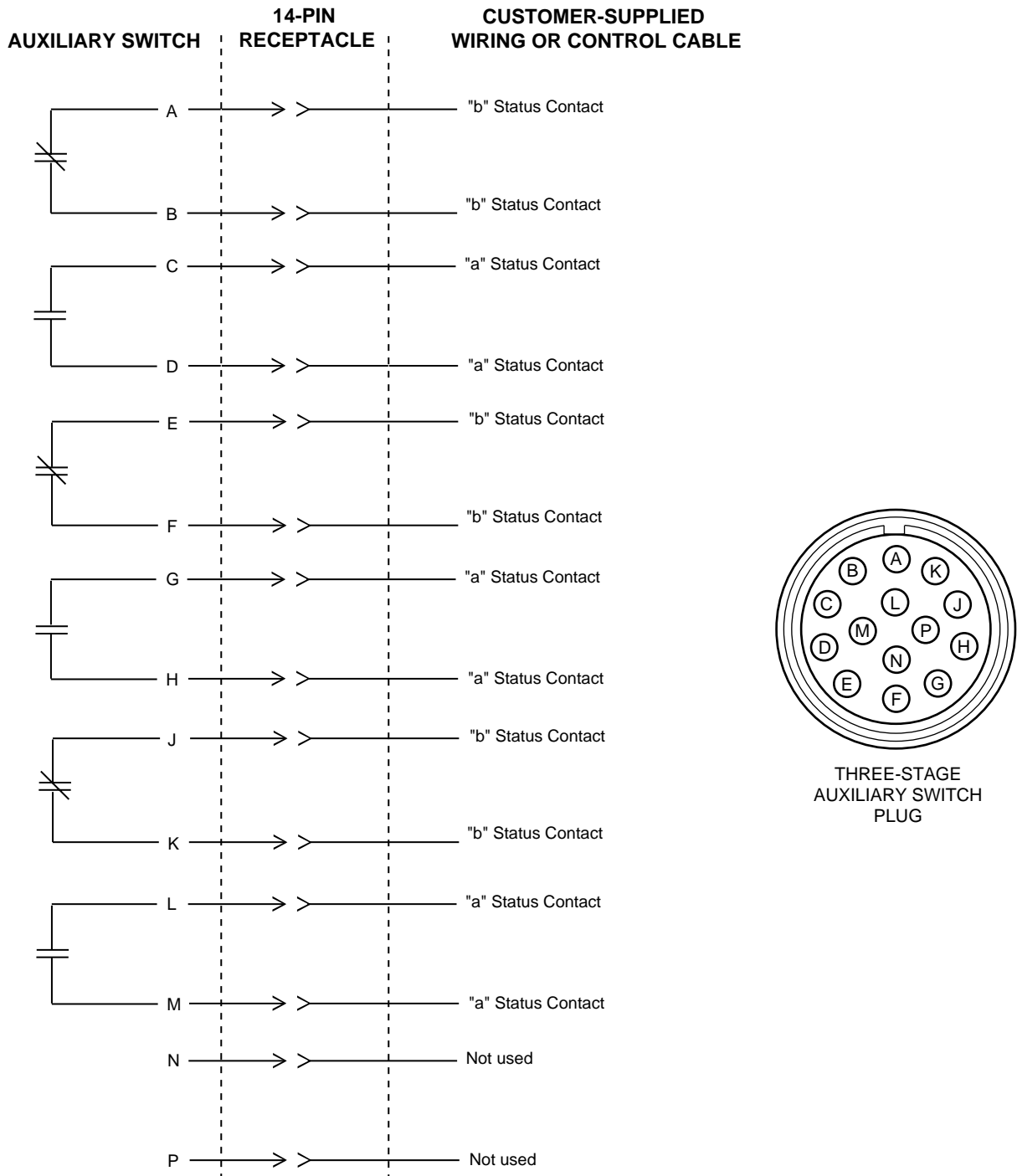

Figure 10.
Three-Stage Auxiliary Switch 14-pin receptacle diagram.

SERVICE INFORMATION

Service Requirements

The Kyle Type VCS-3 switch has been designed with a minimum mechanical life of 10,000 operations. The VCS-3 switch requires routine inspection to check for physical damage and verify proper operation.

Frequency of Inspection

Because these switches are applied under widely varying operating and climatic conditions, service intervals are best determined by the user based on actual operating experience.

High-Potential Withstand Testing

 **WARNING:** Hazardous voltage. The switchgear and high voltage transformer must be in a test cage or similar protective device to prevent accidental contact with high voltage parts. Solidly ground all equipment. Failure to comply can result in death, severe personal injury, and equipment damage. T221.3

 **CAUTION:** Radiation. At voltages up to the specified test voltages, the radiation emitted by the vacuum interrupter is negligible. However, above these voltages, radiation injurious to personnel can be emitted. See *Service Information S280-90-1, Vacuum Interrupter Withstand Test Voltage Ratings Information* for further information. G109.2

Use the following procedures to perform high-potential withstand tests at 75% of the rated low-frequency withstand voltage for 60 seconds. See Table 7 for test voltages.

Test 1

1. Close the switch contacts.
2. Ground the switch.
3. Connect terminals 2, 4, and 6 (see Figure 5) together.
4. Apply proper test voltage (see Table 7) to terminals 2, 4, and 6.
5. The switch should withstand the test voltage for 60 seconds.

Test 2

1. Close the switch contacts.
2. Ground the switch.
3. Ground Phase A (terminal 2) and Phase C (terminal 6).
4. Apply proper test voltage to Phase B (terminal 3).
5. The switch should withstand the test voltage for 60 seconds.

Test 3

1. Open the switch contacts.
2. Ground the switch.
3. Connect and ground terminals 1, 3, and 5 (see Figure 5).
4. Connect terminals 2, 4, and 6.
5. Apply proper test voltage to terminals 2, 4, and 6.
6. The switch should withstand the test voltage for 60 seconds.
7. Reverse the connections: ground terminals 2, 4, and 6.
8. Apply test voltage to terminals 1, 3, and 5 for 60 seconds.
9. The switch should withstand the test voltage for 60 seconds.

Withstand Test Results

The high potential withstand tests provide information on the dielectric condition of the switch and the vacuum integrity of the interrupters.

If the switch passes the closed-contacts tests (Tests 1 and 2), but fails the open-contacts test (Test 3), the cause is likely to be in the interrupter assembly. Retest each phase individually to determine the failed phase or phases.

If the switch fails the closed-contacts tests (Tests 1 or 2), the cause is likely to be a diminished electrical clearance or failed insulation. Retest each phase individually to determine the failed phase or phases.

TABLE 7
Type VCS-3 Switch Vacuum Interrupter Withstand Test Voltage Ratings Information

Description	75% of Rated Low-Frequency Withstand Voltage (1 minute dry) (kV rms)
VCS3-15	37.5
VCS3-27	45.0

Inspection of VCS-3 Module

If the VCS-3 module was exposed to an external flashover, an inspection process is recommended to assure proper operation of the switch. Should the VCS-3 exhibit external flashover attributes (carbon tracking or discoloration), the following procedure is recommended to restore the encapsulation back to its original condition:

1. Remove device from service.
2. Inspect module for damage to the terminals. Remove any damaged terminals and replace.
3. Inspect module for damage to the module rods. If there is damage to the module rods, the module must be replaced.
4. Verify through careful inspection that there is no damage to the housing or head casting that could inhibit proper operation.
5. Clean the damaged module with isopropyl alcohol and a scratch-free, nylon scouring pad to remove any carbon deposit.
6. With a clean rag, apply a thin coat of dielectric silicone grease to the cleaned areas.
7. Confirm the dielectric strength of the module by performing high-potential withstand testing. Confirm both phase-to-ground and phase-to-phase conditions. See the High-Potential Withstand Testing section of this manual.

Replacement Parts

Replacement parts for Kyle switches are available through the factory service department. Only factory authorized parts are to be used. Contact your Cooper Power Systems representative for additional information and ordering procedures.

Factory-Authorized Service Centers

Factory-authorized service centers are located throughout North America to provide maintenance, repair, and testing services for Kyle switches. For further information, contact your Cooper Power Systems representative.

