

Types VXE15 and VXE27 Electronically Controlled, Single-Phase Recloser Maintenance Instructions

Service Information
S280-16-2

Applicable to VXE15 serial numbers 10695 and above or beginning with CP57.

Applicable to VXE27 serial numbers 787 and above or beginning with CP57.



Figure 1.
Kyle® Type VXE Electronically-Controlled, Single-Phase Recloser.

921121KM

Contents

Safety Information	2	Testing with the VXE Control Tester	10
Hazard Statement Definitions	2	Shop Maintenance Procedures	11
Safety Instructions	2	Bushings	11
Product Information	3	Vacuum Interrupter	12
Introduction	3	Closing Coil	13
Description	3	Recloser Head	14
Operation	3	Adjustments	16
Specifications and Ratings	4	Undervoltage Lockout	16
General Maintenance	5	Yellow Operating Handle	17
Frequency of Recloser Maintenance	5	Closing Coil Contactor	18
Periodic Recloser Inspection and Maintenance ..	5	Wiring and Connection Diagram	19
Periodic Control Inspection	6	Maintenance Information	20
Control Maintenance	6	Factory Authorized Service Centers	20
Battery	6	Factory Maintenance Classes	20
Recloser Testing	7	Instructional Video Cassette Program	20
Test Equipment Required	7	Service Parts Lists	21
Minimum Trip Current Level Test	7	Head and Tank	23
Sequence of Operation Test	8	Closing Coil Assembly	24
High-Potential Insulation Level Withstand Tests ..	8	VXE Control	25
Electrical Operation of Closing Coil Test	9		



SAFETY FOR LIFE



Cooper Power Systems products meet or exceed all applicable industry standards relating to product safety. We actively promote safe practices in the use and maintenance of our products through our service literature, instructional training programs, and the continuous efforts of all Cooper Power Systems employees involved in product design, manufacture, marketing, and service.

We strongly urge that you always follow all locally approved safety procedures and safety instructions when working around high voltage lines and equipment and support our “Safety For Life” mission.

SAFETY INFORMATION

The instructions in this manual are not intended as a substitute for proper training or adequate experience in the safe operation of the equipment described. Only competent technicians who are familiar with this equipment should install, operate, and service it.

A competent technician has these qualifications:

- *Is thoroughly familiar with these instructions.*
- *Is trained in industry-accepted high- and low-voltage safe operating practices and procedures.*
- *Is trained and authorized to energize, de-energize, clear, and ground power distribution equipment.*
- *Is trained in the care and use of protective equipment such as flash clothing, safety glasses, face shield, hard hat, rubber gloves, hotstick, etc.*

Following is important safety information. For safe installation and operation of this equipment, be sure to read and understand all cautions and warnings.

Safety Instructions

Following are general caution and warning statements that apply to this equipment. Additional statements, related to specific tasks and procedures, are located throughout the manual.

 **DANGER:** Hazardous voltage. Contact with hazardous voltage will cause death or severe personal injury. Follow all locally approved safety procedures when working around high and low voltage lines and equipment.

G103.3

 **WARNING:** Before installing, operating, maintaining, or testing this equipment, carefully read and understand the contents of this manual. Improper operation, handling or maintenance can result in death, severe personal injury, and equipment damage.

G101.0

 **WARNING:** This equipment is not intended to protect human life. Follow all locally approved procedures and safety practices when installing or operating this equipment. Failure to comply can result in death, severe personal injury, and equipment damage.

G102.1

 **WARNING:** Power distribution equipment must be selected for the intended application. It must be installed and serviced by competent personnel who have been trained and understand proper safety procedures. These instructions are written for such personnel and are not a substitute for adequate training and experience in safety procedures. Failure to properly select, install, or maintain this equipment can result in death, severe personal injury, and equipment damage.

G122.2

Hazard Statement Definitions

This manual may contain four types of hazard statements:

 **DANGER:** Indicates an imminently hazardous situation which, if not avoided, will result in death or serious injury.

 **WARNING:** Indicates a potentially hazardous situation which, if not avoided, could result in death or serious injury.

 **CAUTION:** Indicates a potentially hazardous situation which, if not avoided, may result in minor or moderate injury.

CAUTION: Indicates a potentially hazardous situation which, if not avoided, may result in equipment damage only.

PRODUCT INFORMATION

Introduction

Service Information S280-16-2 describes the maintenance instructions for the Kyle® Type VXE15 and VXE27 single-phase, electronically controlled reclosers. This service information includes a general description of the recloser and operating principles as well as instructions for periodic inspection, testing, and shop repairs. Service parts lists, keyed to exploded view-drawings of the unit, along with ordering information are included in the manual.

Other available VXE Service Information is as follows:

- *S280-16-1 Types VXE15 and VXE27 Electronically Controlled, Single-Phase Recloser Installation and Operation Instructions*
- *S280-16-3 Kyle VXE Electronic Control SCADA Input/Output Board Installation and Operation Instructions*
- *S280-16-4 Type VXE Electronic Recloser Control Tester Operation Instructions*

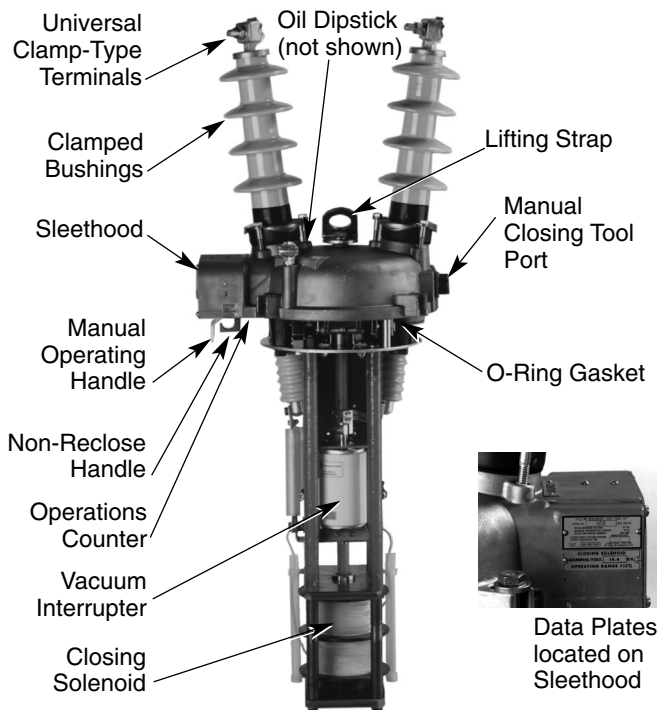

Figure 2.
Untanked view of Type VXE recloser.

921128KM, 921122KM

Description

The Type VXE recloser is a self-contained, single-phase current interrupting device that protects distribution lines and equipment. A complete unit consists of a VXE recloser and a separate control, housed in a cabinet, connected to the recloser with a control cable.

The VXE recloser control uses solid state electronics to provide accuracy, reliability, and flexibility for overcurrent sensing and trip timing. The electronic circuits are housed in a separate weather-proof cabinet that can be attached to the recloser tank or mounted up to 100 feet away and connected to the recloser with a control cable.

Operation

The VXE recloser senses line current and automatically interrupts the phase of the distribution circuit to which it is connected when line current exceeds the programmed minimum trip level. It then automatically recloses to restore service and monitors the line to determine if the fault has been cleared. If the fault is permanent, the recloser locks out after one, two, three, or four preset trip operations. Once locked-out, the recloser must be manually reset to restore service.

To reset the recloser, pull down the manual operating handle; then, raise it up until it latches into position.

Note: The recloser can be reset remotely if equipped with the SCADA Input/Output accessory board, via the remote close feature. Refer to *Service Information S280-16-3 Kyle Type VXE Electronic Control SCADA Input/Output Board Installation and Operation Instructions* for additional information.

Should the fault clear before lockout, the recloser will reset automatically after the selected reset time elapses. The recloser can also be set for non-reclosing operation (lockout after the first trip operation) with a manually operated external non-reclosing lever.

Note: The recloser can be remotely set for non-reclosing operation if equipped with the SCADA Input/Output accessory board, via the remote non-reclosing feature. Refer to *Service Information S280-16-3 Kyle Type VXE Electronic Control SCADA Input/Output Board Installation and Operation Instructions* for additional information.

The trip operations of the recloser can be all fast, all delayed, or a combination of fast and delayed with a maximum of four operations to lockout. Fast operations clear temporary faults before branch line fuses are damaged. Delayed operations allow time for fuses or other downline protective devices to clear to limit permanent faults to the smallest section of line.

Note: Two TCC plug-in cards are required for proper operation.

SPECIFICATIONS AND RATINGS

The recloser will operate effectively only when used within its specified ratings. Consult the following ratings tables and compare to system characteristics at the point of application prior to installation.

**TABLE 1
Voltage Ratings**

VXE15	
Maximum Design Voltage (kV)	15.5
Nominal Operating Voltage (kV)	2.4 – 14.4
Basic Insulation Level (BIL) (kV)	110
60 Hertz Withstand Voltage (kV)	
Dry, one minute	50
Wet, ten seconds	45
Max RIV at 1.0 MHz/9.41 kV (micro-Volts)	100
VXE27	
Maximum Design Voltage (kV)	27.0
Nominal Operating Voltage (kV)	24.9
Basic Insulation Level (BIL) (kV)	150
60 Hertz Withstand Voltage (kV)	
Dry, one minute	60
Wet, ten seconds	50
Max RIV at 1.0 MHz/23 kV (micro-Volts)	100

**TABLE 2
Current Ratings**

Continuous Current Rating (Amps)	
VXE15, VXE27	400
Symmetric Interrupting Current (Amps)	
VXE15, VXE27	8,000
Overload Capability VXE15, VXE27	
125% - 4 Hours (Amps)	500
150% - 2 Hours (Amps)	600
Cable Charging Current	
VXE15 (Amps)	5
VXE27 (Amps)	25
Magnetizing Current (Amps)	
VXE15, VXE27	14
Three-Second Current, Symmetric (Amps)	
VXE15, VXE27	8,000
Surge Current (Amps) VXE15, VXE27	65,000

**TABLE 3
Duty Cycle**

Percent of Maximum Circuit Interrupting Rating	Maximum X/R Ratio	Number of Unit Operations
15-20	4	88
45-55	8	112
90-100	15	32
		Total 232

**TABLE 4
Mechanical Specifications**

Operating Temperature (°C)	
Minimum	-30
Maximum	+40
Closing Mechanism	Spring/Solenoid Operated
Opening Mechanism	Spring Operated
Contact Gap (approximate) (inches)	0.4 – 0.5
Contact Close Time	
Close Signal To Contact Make (seconds)	0.19 – 0.24
Open Contact Travel Time	
Open Signal To Contact Part (seconds)	0.014 – 0.022
Interrupting Time	
Open Signal to Arc Extinction (seconds)	0.016 – 0.036
Allowable Contact Erosion (inches)	0.0625
Mechanical Life (minimum operations)	2500

GENERAL MAINTENANCE

Frequency of Recloser Maintenance

Because reclosers are used under widely varying operating and climatic conditions, maintenance intervals are best determined by the user, based on actual operating experience. To assure proper and trouble-free operation, reclosers must be maintained when they have operated the equivalent of a rated duty cycle, refer to Table 3. In the absence of specific operating experience, the following procedures are recommended:

- A. When the VXE recloser is operated under usual service conditions as defined in ANSI standard C37.60, “Standard Requirements for Overhead, Pad Mounted, Dry Vault and Submersible Automatic Reclosers and Fault Interrupters for AC Systems”, it is recommended that the following maintenance procedures be performed at the completion of an equivalent duty cycle.

Note: ANSI C37.61, “Guide for the Application, Operation, and Maintenance of Automatic Circuit Reclosers”, gives a procedure for converting the rated standard duty cycle into an equivalent duty cycle based on the actual operating duty of the recloser.

- B. If the recloser has not completed an equivalent duty cycle within six years, it is recommended that an inspection be made at that time. See **Periodic Inspection and Maintenance**.

Periodic Recloser Inspection and Maintenance

Each periodic inspection should include the following steps:

- 1. Bypass and remove recloser from service using all locally approved safety practices.

Disconnect the batteries in the control box.

Note: The unit should not be stored or shipped with the batteries connected. Even if the recloser is not in service, connected batteries will still expend energy. Disconnect the batteries when the recloser is not in service.

Disconnect control cable.

- 2. Inspect external components.
 - A. Check for broken bushings, paint scratches, or other mechanical damage.
 - B. Record counter reading in recloser record log.
 - C. Raise the yellow operating handle up and close with manual closing tool. Refer to **Manual Operation of a De-Energized Recloser in Testing** section of *Service Information S280-16-1 Types VXE15 and VXE27 Electronically Controlled, Single-Phase; Installation and Operation Instructions*.
 - D. Pull the operating handle down (open position) to test operation of counter. Leave recloser in open position.

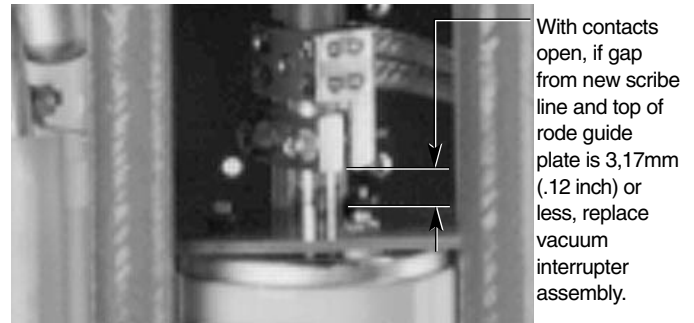

Figure 3.
Measuring vacuum interrupter contact wear.

- 3. Remove mechanism from tank.
 - A. Loosen four bolts that secure tank to head casting.
 - B. Loosen gasket seal between tank and head casting by carefully prying head and tank apart.
 - C. Slowly (to prevent oil loss) hoist mechanism out of tank and allow oil to drain.
- 4. Clean all internal components as required and flush mechanism with clean, dry, transformer oil.
- 5. Block Undervoltage Lockout Operation. Refer to the **Blocking Undervoltage Lockout Operation** procedure in the **Adjustments** section of this manual.
- 6. Close the recloser contacts with a manual closing tool and scribe a line on the contact rod along the rod guide.
- 7. Open the recloser contacts and measure the distance between the scribe line and the top of the rod guide.

If the gap measures 3,17mm (.12 in) or less, replace the vacuum interrupter assembly. Refer to Figure 3.

CAUTION: This equipment relies on oil to provide electrical insulation between components. The dielectric strength of the oil must be checked on a regular basis, as part of the routine maintenance inspection, to ensure that it is at or above minimum dielectric requirements. Use of this equipment with insulating oil that does not meet minimum requirements can result in internal flashovers that will damage the equipment and can cause personal injury. G107.2

- 8. Check dielectric strength of insulating oil.
 - Dielectric strength should not be less than 30 kV when tested with a (2.54 mm) 0.1 inch gap. in accordance with methods in ASTM D117.
 - Low dielectric strength usually indicates presence of water, or carbon deposits.
- 9. Remove old oil. If oil must be replaced, drain tank and clean all carbon deposits.
- 10. Inspect tank liner. Rinse tank with clean oil and wipe out all carbon traces with a clean, lint-free cloth.

Note: Two liners are used. The inner liner is fibrous and readily absorbs any moisture present. Soft or spongy areas indicates that water has been absorbed. Replace liner if these areas are present. The outer liner need not be replaced unless it is damaged.

11. Fill the tank with oil to the level as indicated by the line on fiber liner (4 inches from rim of tank).
12. Replace head gasket every six years or replace if cracked, cut, deformed, or otherwise damaged.
13. Wipe O-ring type head gasket and tank gasket grooves clean.
14. Retain new head gasket with permanent, flexible adhesive (such as Pliobond® 20 Industrial Adhesive).
15. Replace bushing gaskets if cracked, cut, deformed, or otherwise damaged. See Figure 7.
16. On the VXE15, replace terminal gaskets if cracked, cut, deformed, or otherwise damaged. See Figure 8.
17. Replace head and mechanism in the tank.
 - A. Position head so yellow operating handle is above handle warning decal.
 - B. Tighten bolts, alternately, 365-788 N•m (25-40 ft-lbs) torque.
18. After the recloser mechanism has been reinstalled into the tank, check the oil level using the dipstick provided on the recloser head (Figure 4).
19. With the oil temperature at 25°C (77°F), measure the level with the dipstick completely screwed into recloser head.
20. If the oil is below the minimum level, fill the recloser with oil to the proper level, using the dipstick opening. Do not exceed the maximum oil level, as indicated in Figure 4.

Note: The type of dipstick is dependent upon the serial number of the recloser.

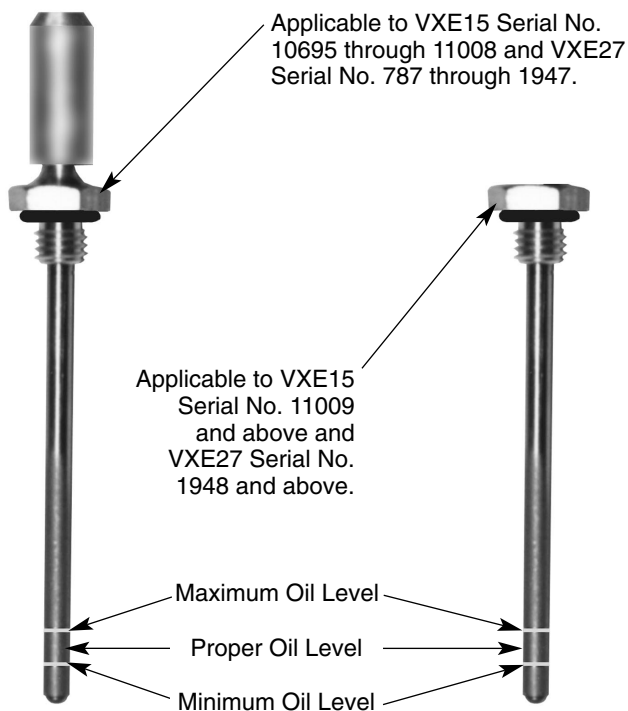

Figure 4.
Type VXE oil dipstick.

951202KM/010064KM

21. Manually operate the yellow operating handle 3 to 4 times to be sure no air remains in hydraulic mechanism of the undervoltage lockout system.
22. Test mechanical operation.
 - A. Move the operating handle up and close with the manual closing tool. The contact position indicator should be in the CLOSED (red) position.

Note: The unit must close before the undervoltage lockout occurs.
 - B. Move the operating handle down. The contact position indicator should be in the OPEN (green) position.
 - C. If the recloser appears to misoperate in any way, additional disassembly and testing is required for identify the source of the malfunction.
23. Perform an Insulation Withstand Test. See procedure in the **Recloser Testing** section of this manual.

Periodic Control Inspection

Each periodic inspection should include a visual inspection of the VXE control.

- Check for paint scratches, wire damage.
- Inspect the door gasket.
- Inspect the battery connection and for battery leakage.
- Inspect the control cable receptacle for wire damage or loose connection.
- Inspect the control cable.

Control Maintenance

The VXE recloser control is a self-powered, single-phase overcurrent electronic recloser control. Control power is supplied by line current through the recloser current transformer. A green LED illuminates when the control is powered off line current. If line current drops below 3 amperes, or the control locks the recloser in the open position; then, power is supplied by the battery.

Battery

The control uses a 9 volt, 1.2 amp-hour lithium battery. The recommended replacement interval is six years. The battery should be replaced if the total accumulated time without CT power reaches 100 days. Battery life may be cut in half with SCADA operations.

Battery Test

Test the battery as follows:

1. Remove battery from the control.
2. Connect a 600Ω resistance across the battery terminals (three second maximum) and observe the voltage across the resistance using a voltmeter (customer-supplied).
3. Voltage must read 7.8Vdc minimum.
 - For temperature below 20°C (70°F), subtract 15.7mV per degree of temperature.
 - For temperature above 20°C (70°F), add 15.7mV per degree of temperature.

RECLOSER TESTING

Test Equipment Required

WARNING: Hazardous voltage. The switchgear and high voltage transformer must be in a test cage or similar protective device to prevent accidental contact with the high voltage parts. Solidly ground all equipment. Failure to comply can result in death, severe personal injury, and equipment damage. T221.3

The following equipment is required for testing:

1. *Variable autotransformer* – 120V, 10 Amps
2. *600:5 BCT* – Kyle KA159W1S type bushing current transformer, set on the 600:5 tap.
3. *Ammeter* – Must have a rating based on the level of test current. Since the control is responsive to peak current, it is recommended that metering responsive to peak current be used when wave distortion is a problem.
4. *High-voltage transformer T1* – Used to operate high-voltage closing coil. Be sure minimum allowable voltage, shown in Table 5, is maintained at recloser terminals during the four- to five-cycle interval the closing coil is energized.
5. *High-voltage test set* – Must be capable of supplying suitable voltages for determining the dielectric withstand capability of the recloser. Sensitive circuit breakers should be included to prevent damage in the event of a flashover.

TABLE 5
Closing Coil Codes and Minimum Voltage

Closing Coil Rating (kV)	Closing Coil Code Number	Minimum Allowable Voltage at Recloser When Coil is Energized (Volts)
VXE15		
2.4	21	2040
4.16 – 4.8	22	3540
6.0	31	5100
7.2 – 7.62	23	6120
8.0 – 8.32	24	6800
VXE27		
11.5	32	9775
12.0 – 13.2	30	10200
14.4	27	12240
Low-Voltage Closing Coils		
120Vac/125Vdc	26	95
240Vac/250Vdc	28	190

Following are several tests that can be performed to determine if a recloser is operating properly.

Minimum Trip Current Level Test

The Minimum Trip Current Level test is to be performed with a VXE recloser and control, and control cable connected. The VXE control battery should be connected and in good condition. See **Battery Test** in the **Control Maintenance** section of this manual.

The minimum trip level selected on the control can be verified by using the manual closing tool to close the recloser while it is de-energized, and then applying test current, and tripping the recloser with the low-voltage ac source. Assemble and connect the low-voltage test portion of the set-up shown in Figure 5 and proceed as follows:

CAUTION: Equipment damage. Do not attempt to trip a recloser by operating the manual closing tool from CLOSED to OPEN. This will result in damage to the recloser operating mechanism. T228.0

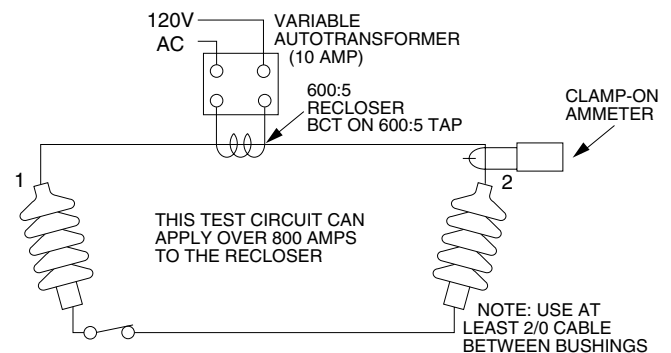

Figure 5.
Suggested test diagram for minimum trip testing.

Note: Set all Cold Load Pickup settings (S9 dip switch on VXE control) to OFF during Minimum Trip Current test.

Note: Set Operations On TCC1 (S3 dip switch) to one operation.

1. With the yellow manual operating handle in the UP position, use the manual closing tool to close the recloser. Refer to *S280-16-1 Type VXE Installation and Operation instructions, Manual Closing Procedure*.
2. Connect the low-voltage test leads to the recloser bushings as shown in Figure 5.
3. Slowly increase the variable-auto-transformer voltage from zero and note the ammeter reading when the recloser trips and compare to the VXE control's programmed minimum trip value.

Sequence of Operation Test

The operating sequence can be checked by using the manual closing tool to close the recloser while it is de-energized and then tripping the recloser with the low voltage ac source.

1. Check the number of programmed fast and delayed operations by observing the VXE control dip switch setting for Operations to Lockout (labeled S2) and the number of TCC1 fast operations programmed on dip switches labeled S3.
2. With the yellow manual operating handle in the UP position, close the recloser with the manual closing tool.
3. Using the customer-supplied variable autotransformer, apply a test current above the minimum trip level to trip the recloser.
4. Reclose the recloser with the manual closing tool after the programmed reclose time interval has elapsed (plunger drops) and before undervoltage lockout occurs, a minimum of 10 seconds at 25°C (77°F). Refer to S7 dip switch on VXE control for programmed reclose time.
5. Repeat Steps 3 and 4 until the recloser locks out; this is indicated by the orange control lockout indicator target on the bottom of the control cabinet.

Test Results

The number of fast and delayed operations-to-lockout must match the programmed values.

Note: If the recloser is to remain off-line for additional testing, unplug the control battery after the preceding testing is complete.

High-Potential Insulation Level Withstand Tests



WARNING: Hazardous Voltage. The switchgear and high voltage transformer must be in a test cage or similar protective device to prevent accidental contact with the high voltage parts. Solidly ground all equipment. Failure to comply can result in death, severe personal injury, and equipment damage. T221.3

High potential withstand tests provide information on the dielectric condition of the recloser. Testing is performed at 75% of the rated low-frequency withstand voltage.

- Test a VXE15 recloser at 37.5kV rms.
- Test a VXE27 recloser at 45.0kV rms.

Closed-Contacts Hi-Pot Test

1. Manually close the recloser contacts.
2. Ground the recloser head casting and control.
3. Apply the proper test voltage to the source-side bushing.
4. The recloser should withstand the test voltage for 60 seconds.

Open-Contacts Hi-Pot Test

1. Pull down the manual operating handle to open the recloser contacts.
2. Ground the recloser head casting, control, and load-side bushing.
3. Apply the proper test voltage to the source-side bushing.
4. The recloser should withstand the test voltage for 60 seconds.
5. Ground the source-side bushing.
6. Apply the proper test voltage to the load-side bushing.
7. The recloser should withstand the test voltage for 60 seconds.

Test Results

The high potential withstand tests provide information on the dielectric condition of the recloser and the integrity of the vacuum interrupter.

If the recloser passes the closed-contacts test, but fails the open-contacts test, the cause is likely to be a deterioration of the vacuum interrupter. Replace the interrupter and retest to confirm the repair.

If the recloser fails the closed-contacts test, the cause is likely to be a diminished electrical clearance, low oil dielectric strength, or failed insulation. After correcting the problem, retest to confirm the repair.

Electrical Operation of Closing Coil Test

Refer to Figure 6 to connect the equipment. On units with line-to-ground closing coils, the recloser head casting and the control must be solidly grounded and in a test cage.

WARNING: Hazardous Voltage. The switchgear and high voltage transformer must be in a test cage or similar protective device to prevent accidental contact with the high voltage parts. Solidly ground all equipment. Failure to comply can result in death, severe personal injury, and equipment damage. T221.3

1. Lower the yellow operating handle to LOCKOUT position.
2. Raise the yellow operating handle to the UP position. Apply high voltage to the source-side bushing within 10 seconds. The recloser should close immediately (contact position indicator "CLOSED"), indicating correct operation of the closing coil.

The operations described in this section should be done under the cleanest conditions possible. The repair work, except for bushing replacement, will be simplified if the workbench is arranged so the mechanism can be inverted (bushings down). No special tools are required for any of the repair procedures.

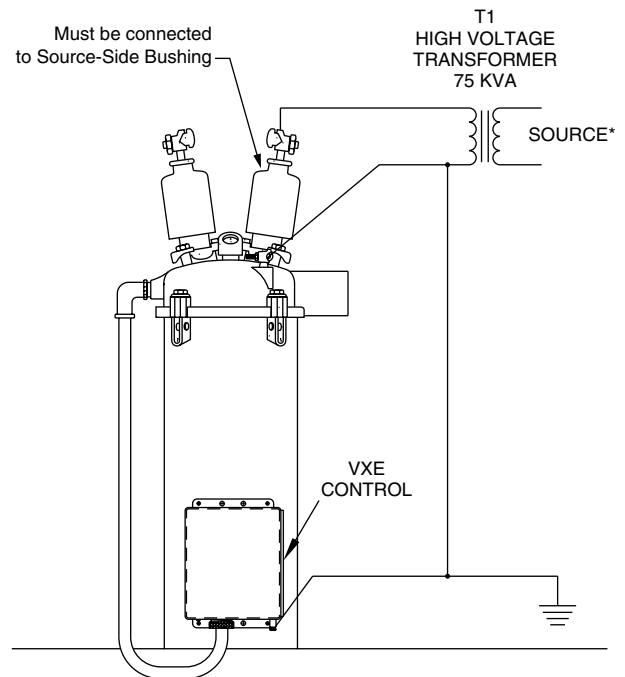

*Source shall not limit the KVA output of the transformer.

Figure 6.
Suggested test diagram for high voltage closing.

TESTING WITH THE VXE CONTROL TESTER

Service Information S280-16-4 VXE Recloser Control Tester Operation Instructions provides testing procedures for the VXE Control with the Type VXE Electronic Recloser Control Tester. Before operating this unit, carefully read and understand the contents of this manual.

The Kyle® Type VXE electronic recloser control tester is designed specifically for testing the Kyle Type VXE electronically controlled, vacuum single-phase recloser. The tester has the capability to check the following:

- Recloser Test
- Battery Test
- Minimum Trip Test
- Control Operating Test
- Time-Current Curve Characteristics Test
- Minimum Response Time
- Time-Current Curve Characteristics Mode
- Reclosing Time Test
- Reset Time Test
- Cold Load Time Test
- SCADA Functions Test

The tester can check the operation of the electronic recloser control and the electrical operation of the recloser with the exception of high voltage closing. However, the control cannot operate the recloser through the tester.

A recloser-simulator circuit is built into the tester to simulate recloser operation (indicated by red and green lights on the tester panel labeled RECLOSER SIMULATOR) and to simulate the response time of the recloser mechanism to trip and close signals. The RECLOSER SIMULATOR provides a time delay to duplicate the interrupting time of a Type VXE recloser in response to a trip signal from the control when recloser clearing time tests are being conducted.

SHOP MAINTENANCE PROCEDURES

Bushings

Bushing maintenance generally consists of cleaning the bushings thoroughly and examining carefully for cracks or other damage while the recloser is untanked for servicing. Cracked or damaged bushings must be replaced.

Note: The bushings used on the Type VXE27 recloser are oil filled and must be replaced as an assembly. Recloser untanking is required to replace these bushings.

Replacing VXE15, VXE27 Bushing Assembly

Secure the recloser to a suitable work rack. Refer to Figure 7 and proceed as follows:

1. Untank the recloser and disconnect the bushing lead by removing the screw and lockwasher. (See Item 8 and 9, Figure 23).
2. Remove three hex-head cap screws and bushing clamps that secure bushing to head casting. Lift bushing assembly from head. Discard bushing gasket.
3. Twist aluminum clamping ring and remove from old bushing assembly. If ring is in good condition it may be reused. If ring is damaged, it must be replaced.



CAUTION: Bushing damage. The split aluminum ring must be replaced if damaged. The clamping ring cushions and distributes the pressure between the bushing flange and the bushing. If the bushing clamps are assembled without a new clamping ring, the bushing may be damaged when clamping hardware is tightened.

T234.1

4. Position a new bushing gasket between bushing flange and head casting.
5. Install new bushing assembly.
6. Position aluminum clamping ring so split will be centered between two clamping bolts.



CAUTION: Dielectric failure; bushing damage. To prevent gasket leaks or bushing damage, clamping force must be applied gradually and equally in rotation to each bolt. If the clamping force is not evenly applied, seal leakage can result, compromising the dielectric capabilities of the recloser. Unequal clamping force can cause bushing breakage.

T235.1

7. Replace bushing clamps and tighten cap screws evenly, a little at a time, to 146-219 N•m (10-15 ft-lbs.)
8. Reconnect bushing lead and tank the recloser.
9. Perform a hi-potential withstand test as described in the **Recloser Testing** section of this manual.

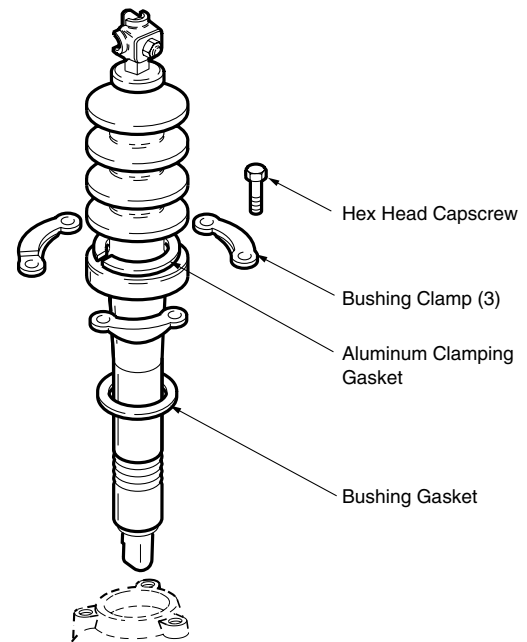

Figure 7.
Bushing replacement (VXE27) .

Replacing VXE15 Bushing Porcelain

The porcelain on a VXE15 recloser can be replaced without untanking the recloser. Secure the recloser to a suitable work rack and refer to Figure 8.

1. Turn the bushing terminal counterclockwise to remove it. Lift off the terminal gasket.

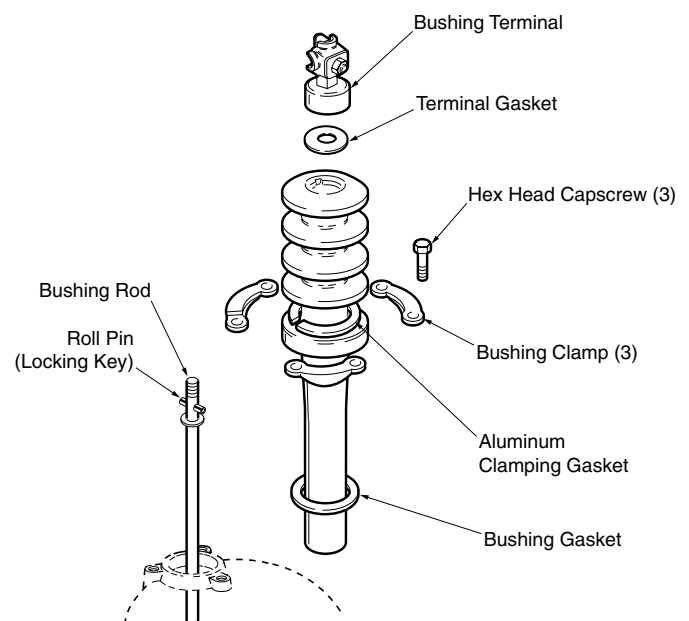

Figure 8.
Bushing porcelain replacement (VXE15).

2. Remove three hex-head cap screws and bushing clamps that secure bushing to head casting. Lift the porcelain out of the head casting.
3. Position a new bushing gasket on the head casting.
4. Slide new porcelain over the bushing lead and turn it so the terminal on the lead is seated properly with the locking key.
5. Remove the aluminum clamping gasket from the old bushing and put it on the new porcelain.
6. Replace bushing clamps and tighten cap screws evenly, a little at a time, to 146-219 N•m (10-15 ft-lbs).
7. Replace the terminal gasket and terminal and torque to 292-365 N•m (20-25 ft-lbs).

Vacuum Interrupter

The vacuum interrupter must be replaced when any of the following occur:

- It loses its vacuum, as evidenced by a failure during the low-frequency dielectric withstand test across the open contact.
- The interrupter contacts have eroded beyond their useful life as evidenced by travel of the moving contact rod.

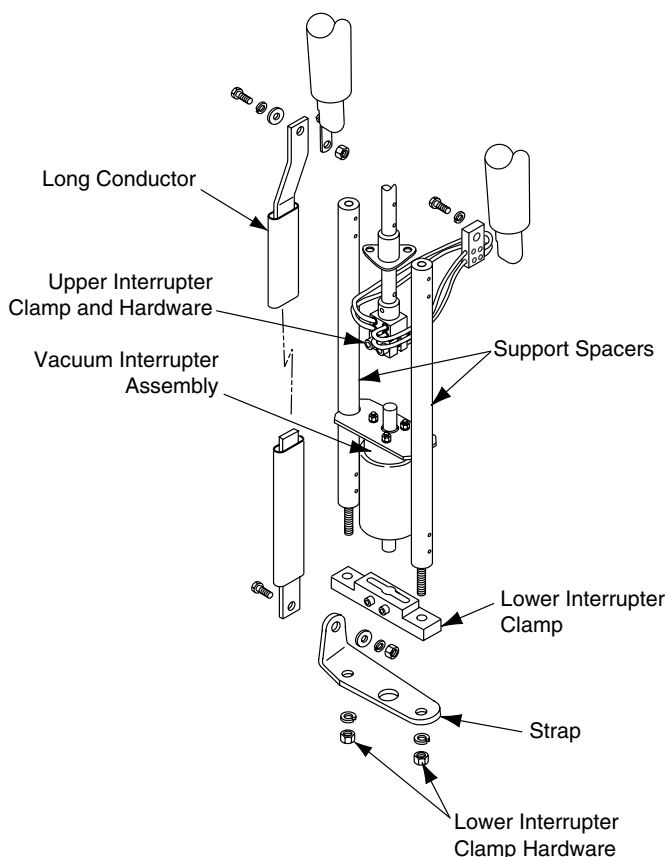

Figure 9.
Vacuum Interrupter replacement.

To replace the vacuum interrupter, refer to Figure 9 and proceed as follows:

1. Trip the recloser open by pulling down the manual operation handle.
2. Untank the recloser.
3. Remove the hardware securing the long conductor at the bushing end.
4. Loosen the two socket head screws on the upper vacuum interrupter clamp.

CAUTION: Equipment damage. Do not twist or apply radial pressure to the vacuum interrupter movable contact rod. Excessive twisting or pressure on the contact rod will damage the interrupter bellows, which can cause equipment failure. T211.0

5. Loosen the two hex head capscrews on the lower vacuum interrupter clamp.
6. Disconnect the long conductor from the strap located below the lower clamp.
7. Loosen and remove the two nuts that secure the lower clamp and the strap to the insulating stringers.
8. Remove the strap located below the lower clamp
9. Remove the lower clamp and vacuum interrupter.
10. Remove the the three hex nuts and lockwashers connecting the contact guide to the vacuum interrupter.
11. Remove the guide plate and install on the replacement vacuum interrupter using the same hex nuts and lockwashers.
12. Set the replacement interrupter into the lower clamp and loosely tighten the two hex head capscrews to secure the moving contact of the interrupter. See Figure 10.

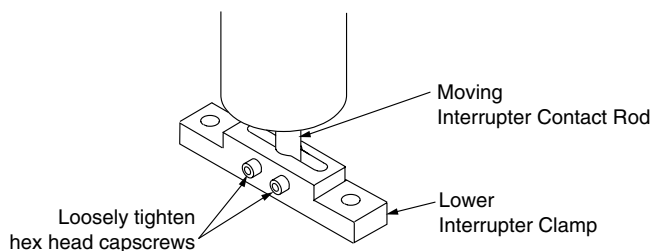

Figure 10.
Positioning of lower interrupter clamp.

13. Install the clamp and interrupter to the insulating stringers.
14. Replace the strap underneath the lower clamp and secure all three items with the two hex nuts previously removed from the stringers.
15. Reconnect the long conductor to the strap.

CAUTION: Equipment damage. Do not use any tools to push on the undervoltage lockout piston. Using tools can damage the piston or its housing, causing recloser misoperation or equipment damage. T288.0

16. Block the Undervoltage Lockout by pushing down on the undervoltage lockout piston and installing a cotter pin into the exposed hole in the piston shaft. The hole is located just below the plate. See **Blocking Undervoltage Lockout** in the **Adjustments** section of this manual.
17. Raise the yellow operating handle and close the unit with the manual closing tool.

Note: The moving contact must bottom in the upper interrupter clamp assembly.
18. Tighten the upper and lower clamp hardware to 8,5 N•m (75 in/lbs).
19. With the contacts closed, scribe a line around the moving contact rod of the interrupter at the top of the contact rod guide.
20. Open the recloser
21. Measure the contact travel by measuring the distance from the top of the contact guide plate to the scribe line created in Step 19. See Figure 11. Measurement must be 10,2 to 12,7 mm (.400 to .500 in).

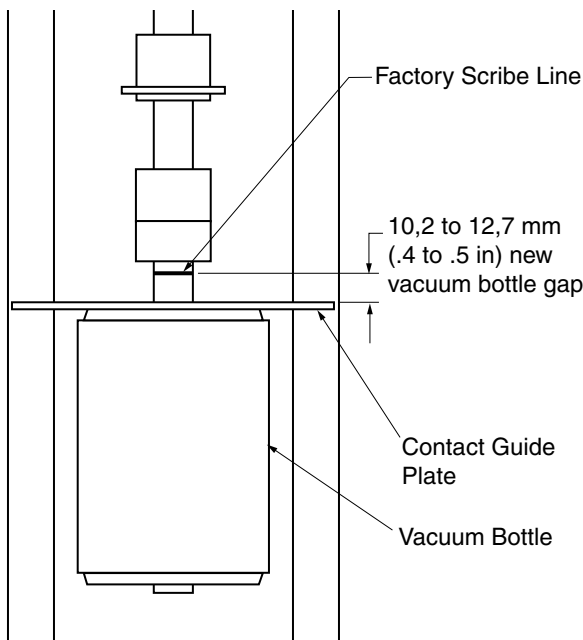

Figure 11.
Measuring contact travel.

22. Retank and test the recloser as described in the **Recloser Testing** section of this manual.

Closing Coil

If the closing coil has been damaged or if the recloser is to be changed to a new rating, the closing coil and fuse must be replaced. For replacement, refer to Figure 12 and the following procedure:

Note: A new closing coil data plate is provided with each coil. This data plate must be installed on the sleet hood when the coil is replaced. See Figure 2.

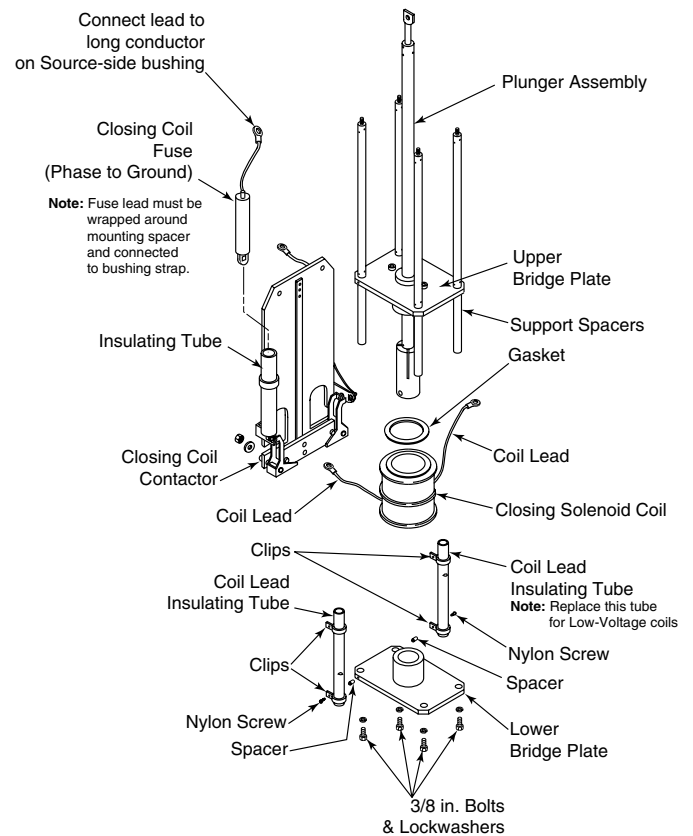

Figure 12.
Closing coil replacement.

1. Pull down the manual operating handle to trip the recloser.
2. Untank the recloser.
3. Remove the two nylon screws, spacers, and clips from each coil lead insulating tube connected to the bridge plate assemblies.
4. Disconnect the coil leads from the closing coil contactor. Reconnect the hardware to the contactor to avoid losing it.
5. Slide the coil leads out of the insulating tubes. Place the tubes and hardware aside for re-use.

Note: If replacing a 125V or 250V low-voltage closing coil, use the slotted tube provided in the new closing coil kit to accommodate the diode on low-voltage coils.
6. Remove the four bolts that secure the lower closing coil bridge plate to the support spacers.

7. Remove the bridge plate from the coil.
8. Remove the coil and gasket and discard.

Closing Coil Fuse Removal and Replacement

9. Disconnect the fuse lead from the long conductor on the *source* side bushing (Figure 12).
10. Pull the fuse lead through the insulating tube (Figure 12) and unwind from mounting spacer.
11. Disconnect the fuse from the closing coil contactor (Figure 12) by removing the nut and washer.
12. Pull the fuse from the insulating tube and discard.
13. Place new fuse in the insulating tube and connect to the closing coil contactor with the washer and nut previously removed.
14. Thread the fuse lead through the slot near the mounting spacer and wrap it around the spacer.
15. Thread the remaining portion of the lead through the slot on the opposite side of the insulating tube and connect it to the long conductor on the *source*-side bushing.

New Coil Assembly

16. Place the new closing coil over the lower bridge plate.
 17. Place new gasket on the new closing coil.
 18. Secure the lower bridge plate to the support spacers with the existing hardware previously set aside.
 19. Thread the coil leads through the insulating tubes and secure them to the solenoid contactor.
 20. Reattach the clips to the insulating tubes and secure them to the upper and lower bridge plates with the nylon screws and spacers.
- Note:** Be careful not to strip the threads of the nylon screws.
21. Retank and test the recloser as described in the Recloser Testing section of this manual.

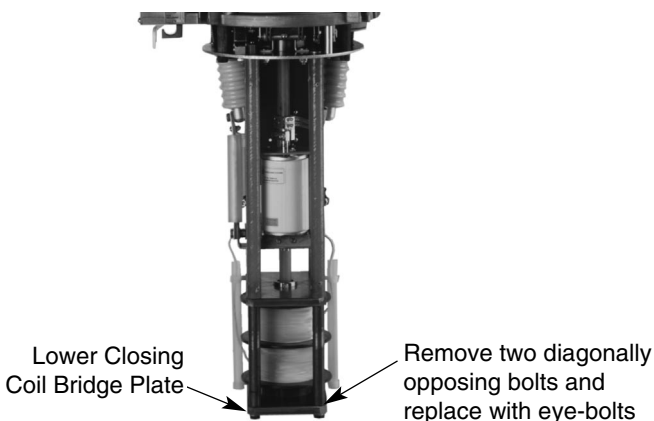

Figure 13.
Closing coil bridge plate.

Recloser Head

Disassembly

Disassembly of head should not be required. Should it become necessary, follow these steps:

1. Pull down the manual operating handle to trip the recloser.
2. Untank the recloser.
 - A. Loosen four bolts that secure the tank to the head casting.
 - B. Loosen the gasket seal between the tank and the head casting. Gasket seal can be broken by carefully prying head and tank apart. Hoist the mechanism out of the tank and allow oil to drain.

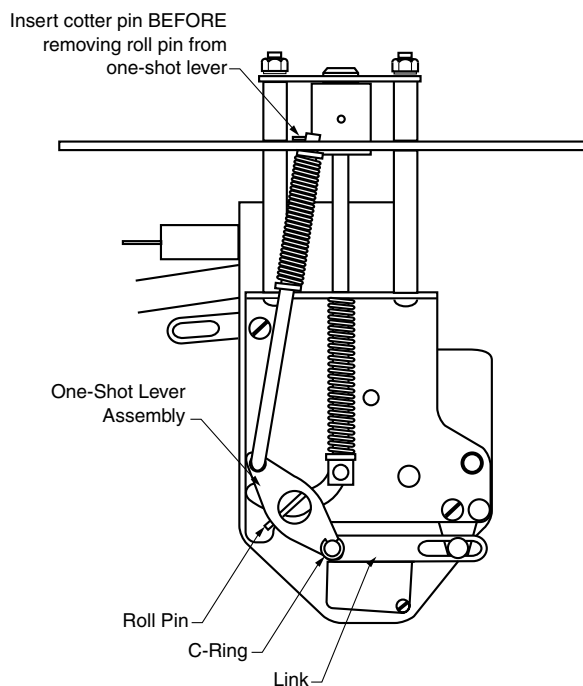

Figure 14.
Removing the roll pin in one-shot lever assembly (inverted).

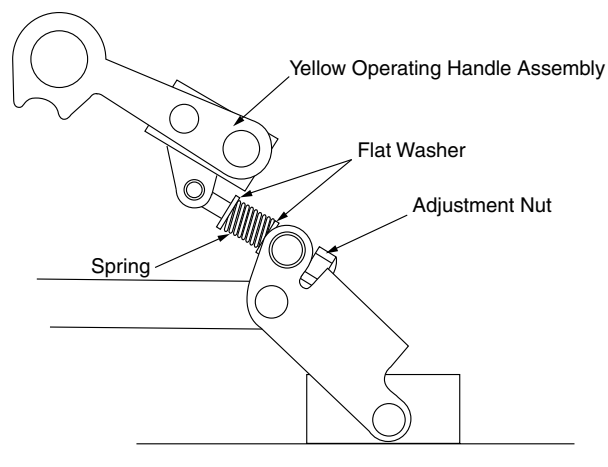

Figure 15.
Yellow operating handle adjustment nut.

3. Remove the bushings and sleet shield. Refer to **Replacing Bushing Assembly** section.
4. Remove two diagonally opposing 3/8 inch bolts that secure the closing coil bridge plate to the stringers. See Figure 13.
5. Temporarily replace with 3/8 inch eye bolts (customer-provided).
6. Invert the recloser (positioned in work rack) and suspend from eye bolts.
7. Insert a cotter pin (customer provided) in the one-shot lever assembly. This will hold the one shot rod assembly in place during disassembly.
8. Drive out the roll pin in the one-shot lever assembly. This must be done through the source-side bushing hole of the head casting. See Figure 14.
9. Slide the one-shot lever assembly out and remove it from the aluminum block.
10. Remove the C-ring from the pin that passes through the link of the counter shaft assembly. Remove the pin and link (Figure 23, Item 42).
11. Remove the yellow operating handle adjustment nut, two flat washers, and spring. See Figure 15.
12. Remove the ground lead connected to the head assembly and replace screw and lockwasher.
13. Loosen the four hex head capscrews that secure the mechanism to the head. See Figure 16.
14. Remove the capscrew and spacer next to the head connector. See Figure 16.
15. Disconnect the head connector. See Figure 16.
16. Remove the three remaining capscrews and spacers.
17. Lift the recloser mechanism from the head using the eye bolts installed earlier in this procedure.

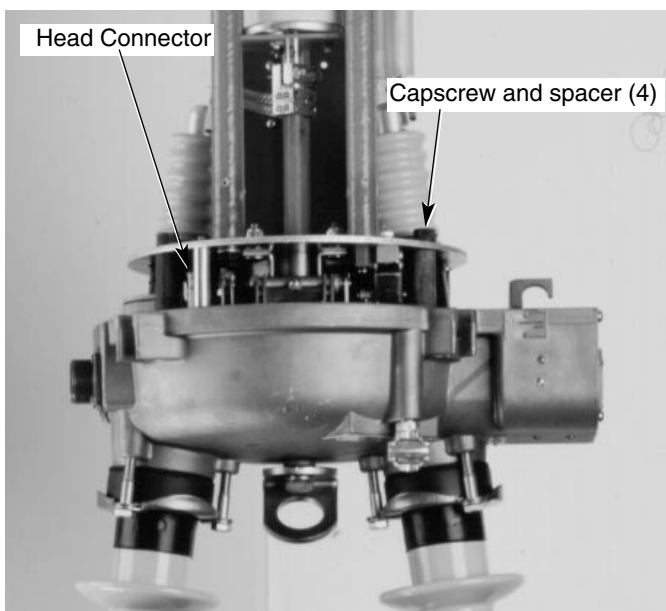

Figure 16.
Disconnecting head connector and removing hardware holding mechanism to head.

Assembly

The VXE recloser head can be assembled by reversing the disassembly procedures.

1. How is the mechanism lined up with the head for re-assembly? Align the recloser head with the mechanism and ease the mechanism onto the head.
2. Replace the spacers and capscrews (except the one located next to the head connector) that secure the head to the mechanism. See Figure 16.
3. Tighten capscrews. Do not torque.
4. Reconnect the head connector. See Figure 16.
5. Replace the capscrew and spacer next to the head connector.
6. Tighten all four capscrews that secure the recloser head to the mechanism.
7. Attach the lead to the head assembly with the screw and lockwasher.
8. Replace the yellow operating handle spring, two flat washers and adjustment nut. See Figure 15.

Note: Adjust the yellow operating handle after the head is assembled and before the recloser mechanism is secured to the head. See Figure 19.
9. Replace the pin through the link of the countershaft assembly.
10. Replace the C-ring on the pin.
11. Insert the roll pin into the one-shot lever assembly.
12. Remove the cotter pin that held the one-shot rod assembly in place.
13. Return the assembled head and recloser mechanism to an upright position.
14. Remove the 3/8" eyebolts from the closing coil bridge stringers and replace with the original 3/8" bolts.
15. Re-assemble the bushings. See **Replacing Bushing Assembly** section.
16. Block undervoltage lockout. Refer to **Blocking Undervoltage Lockout Operation** in the **ADJUSTMENTS** section of this manual.
17. Adjust the yellow operating handle. Refer to **Yellow Operating Handle** in the **ADJUSTMENTS** section of this manual.
18. Unblock undervoltage lockout by removing the cotter pin from the piston shaft. Refer to **Blocking Undervoltage Lockout Operation** in the **ADJUSTMENTS** section of this manual.
19. Replace the sleet shield.
20. Lower the mechanism into the recloser tank and secure the head with the four bolts.

ADJUSTMENTS

Undervoltage Lockout

CAUTION: Equipment damage. Do not use any tools to push on the undervoltage lockout piston. Using tools can damage the piston or its housing causing recloser misoperation or equipment damage.

T288.0

The Undervoltage Lockout feature protects the high voltage closing coil from thermal damage. The undervoltage lockout system protects the closing coil with a spring-biased hydraulic time-delay lockout linkage charged by the closing stroke of the closing coil or by the operating handle.

Each closing signal initiates a time-delayed lockout operation with the down stroke of the solenoid plunger. The time-delay is 10 to 30 seconds. If sufficient voltage is present and the oil is filled to the proper level, a closing operation occurs and the undervoltage lockout linkage is reset. If system voltage is too low to permit a closing operation, or if the oil level is low, the linkage will provide lockout following its time delay.

The undervoltage lockout piston housing can be set to three positions to achieve the proper time-delay lockout setting of 10 to 30 seconds. This setting is set at the factory but can be adjusted.

The setting is adjusted by positioning the two washers below the undervoltage lockout piston housing in one of three configurations. See Figure 17.

- max time = Both washers between the piston housing and the plate.
- mid time = One washer between the piston housing and plate. One washer between plate and snap ring.
- min time = Both washers between the plate and the snap ring.

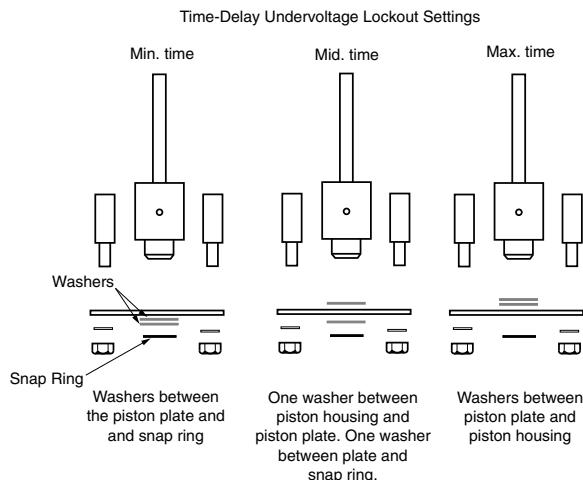
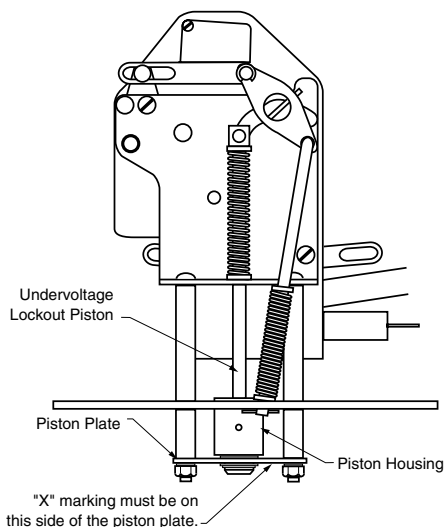

To change the time-delay lockout setting:

1. Remove the two nuts and lockwashers that secure the undervoltage lockout piston housing assembly to the mechanism. Set the hardware aside.
2. Remove the piston housing assembly.
3. Remove the snap ring and reposition the washers for the desired time-delay setting.

CAUTION: Equipment damage. Do not use any tools to push on the undervoltage lockout piston. Using tools can damage the piston or its housing causing recloser misoperation or equipment damage.

T288.0

IMPORTANT: When repositioning the plate to the piston housing, be sure the "X" marking faces away from the recloser head (Figure 17).

4. Re-install the snap ring.
5. Re-install the undervoltage lockout piston housing and secure with the two nuts and washers previously set aside.
6. Check the oil level in the recloser tank. Fill if necessary.
7. Retank the recloser.
8. Test the undervoltage lockout timing setting.
 - A. Operate the yellow operating handle 3 or 4 times to expel any trapped air.
 - B. Raise the yellow handle and time how long it takes for the handle to drop down.
 - C. Handle should drop between 10 to 30 seconds at 25°C (77°F).

Figure 17.
Setting Undervoltage Lockout by positioning washers on the piston housing.

Blocking Undervoltage Lockout Operation

There is no need to disassemble the piston assembly to block undervoltage lockout operation. Follow these steps:

1. Pull the yellow operating handle down (contacts open).
2. Untank the recloser.
3. Push the piston into the piston housing, with your finger only, to expose the hole in the piston shaft.
4. Install a cotter pin through the hole in the piston shaft. See Figure 18.

The yellow operating handle can be moved to the UP position and remain there when the cotter pin is inserted, blocking undervoltage lockout.

Note: Unblock the undervoltage lockout before returning the recloser to service.

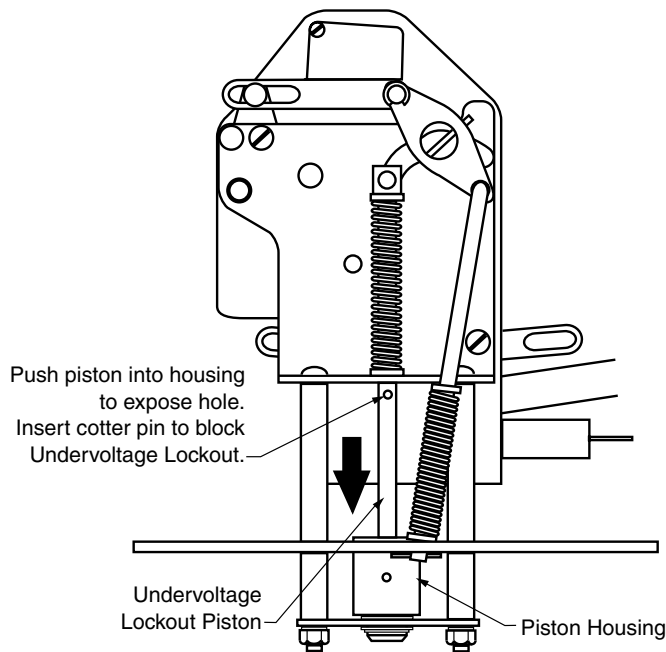

Figure 18.
Blocking Undervoltage Lockout.

Yellow Operating Handle

The yellow operating handle can be adjusted using two shims to determine its proper position.

1. Pull the yellow operating handle down.
2. Untank the recloser.
3. Block the undervoltage lockout. See **Blocking Undervoltage Lockout Operation** section. When the undervoltage lockout is blocked, the yellow operating handle will remain in the up position.

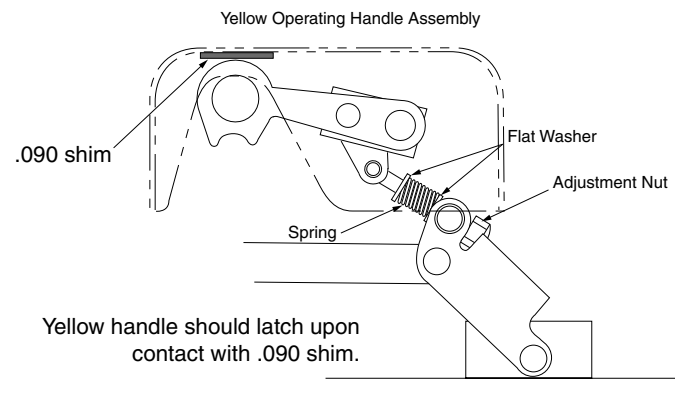

Figure 19.
Adjusting yellow operating handle.

4. Place a .090 inch shim between the operating handle and the sleet hood. The yellow handle should latch upon contact with the .090 shim. See Figure 19.
5. If the handle does not latch upon contact, adjust the yellow operating handle stop nut.
6. Place a .120 inch shim between the operating handle and the sleet hood.
The yellow handle should NOT latch upon contact with the .120 shim.
7. Continue adjusting stop nut until handle is positioned properly.
8. Unblock undervoltage lockout.

Closing Coil Contactor

Adjusting the closing coil contactor is normally not necessary. If adjustment is required, a manual closing tool must be used to adjust the coil contactor. The manual closing tool permits closing of the main contacts on a de-energized recloser.

WARNING: Hazardous voltage. Never use a manual closing tool to close an energized recloser. Manually closing an energized recloser will result in failure of the vacuum interrupter and can result in contact with high voltage, which can cause death and severe personal injury.

T236.0

A de-energized recloser is manually closed by raising the yellow operating handle to the Closed position and using the manual closing tool to rotate the main operating shaft of the recloser mechanism 90°. Rotation must be completed before the undervoltage lockout feature operates. Therefore, the undervoltage lockout feature must be blocked prior to adjustment of the closing coil contactor.

To test the adjustment of the closing coil contactor:

1. Pull the yellow operating handle down (contacts open).
2. Untank the recloser.

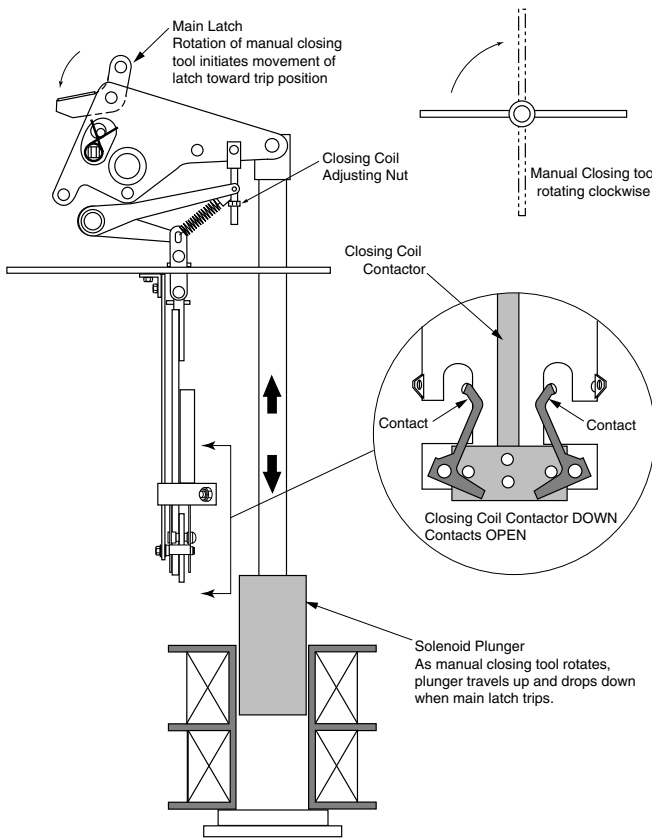

Figure 20. Closing Coil Contactor. Yellow operating handle DOWN. Main latch positioned prior to tripping. Contacts are open.

3. Remove the manual closing tool port plug.
4. Block the undervoltage lockout.
5. With the operating handle in the down position, rotate the manual closing tool clockwise, tripping the main latch. See Figure 20.
With the yellow operating handle in the down position, rotating the manual closing tool clockwise will cause the coil plunger to travel up and drop down when the main latch is tripped.
6. Release pressure on the manual closing tool allowing it to rotate counterclockwise 1/2 of its total travel range. See Figure 21.
7. Hold the manual closing tool in this position and raise the yellow operating handle.
8. Let the manual closing tool slowly continue to rotate counterclockwise until the the main latch makes (clicks). See Figure 21.

Note: The main latch must make (click) before the closing coil contactor closes.

The closing coil contactor will snap closed. The manual closing tool will briefly continue to travel in a counterclockwise direction and then stop.

If the contactor is not operating correctly, adjust by turning the stop nut and repeat the procedure for adjusting the closing coil contactor.

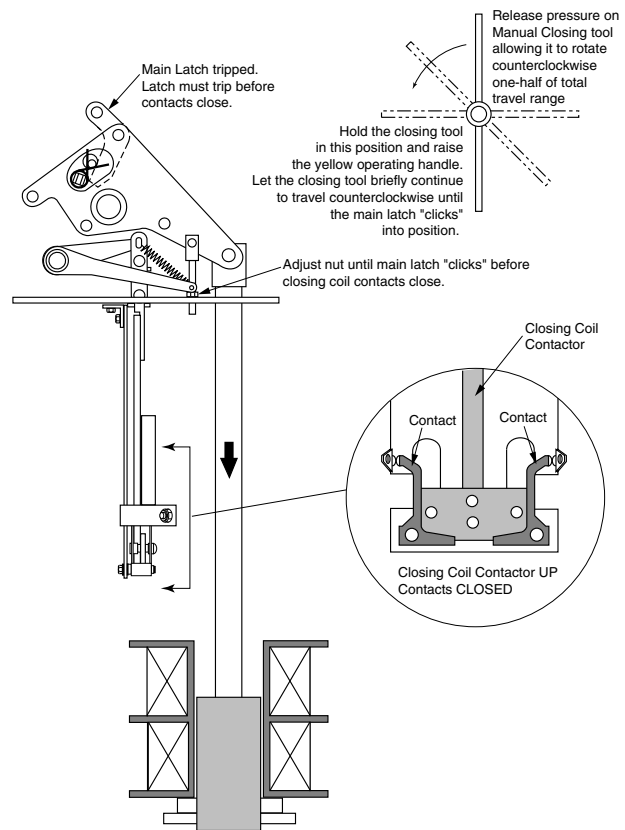
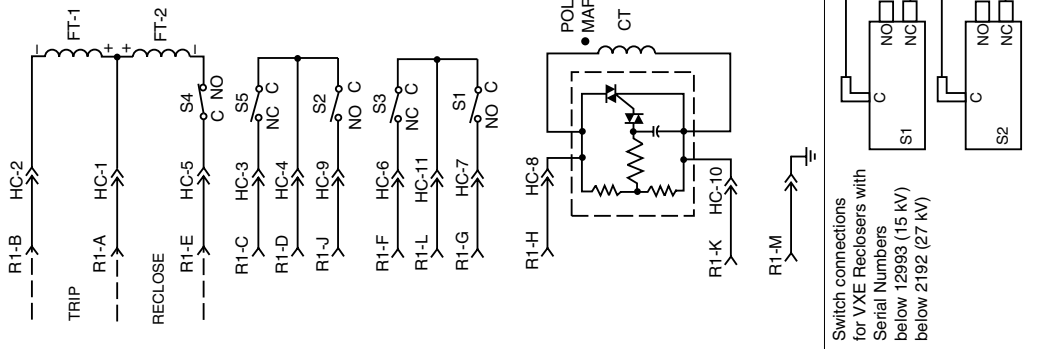

Figure 21. Closing Coil Contactor. Yellow operating handle UP. Contacts close after main latch trips.

LEGEND

Symbol	Description	Ohmmeter Probes	Condition	Resistance Value
R1	Receptacle, 14-pin			
HC	Head Connector, 12-pin	H-K		11.5 ohms
CT	Current Transformer			
P	CT Protector			
FT-1	Trip - Magnetic Actuator	A-B	Recloser main contacts are OPEN	6.5 ohms
FT-2	Close - Magnetic Actuator	A-E	Recloser main contacts are OPEN	6.5 ohms
S1	Switch	A-E	Recloser main contacts are CLOSED	Infinite
S2	Switch	L-G	Yellow Handle UP and Non-Reclose Handle UP	Continuity
S3	Switch	L-G	Yellow Handle DOWN and Non-Reclose Handle UP	Infinite
S4	Switch	D-J	Yellow Handle UP and Non-Reclose Handle UP	Continuity
S5	Switch	D-J	Yellow Handle DOWN and Non-Reclose Handle UP	Infinite
S3	Switch	F-L	Recloser main contacts are OPEN	Infinite
S4	Switch	F-L	Recloser main contacts are CLOSED	Continuity
S4	Switch	A-E	Reclose circuit closed when unit is open	6.5 ohms
S4	Switch	A-E	Reclose circuit open when unit is open	Infinite
S5	Switch	C-D	Recloser main contacts are OPEN	Infinite
S5	Switch	C-D	Recloser main contacts are CLOSED	Continuity



NOTE: Diagram shown with unit OPEN and yellow operating handle down (LOCKOUT).

Figure 22.
Wiring and Connection Diagram for the VXE Recloser and VXE Control.

MAINTENANCE INFORMATION

 **CAUTION:** This equipment requires routine inspection and maintenance to ensure proper operation. If it is not maintained, it can fail to operate properly. Improper operation can cause equipment damage and possible personal injury. G105.1

 **CAUTION:** This equipment relies on oil to provide electrical insulation between components. The dielectric strength of the oil must be checked on a regular basis, as part of the routine maintenance inspection, to ensure that it is at or above minimum dielectric requirements. Use of this equipment with insulating oil that does not meet minimum requirements can result in internal flashovers that will damage the equipment and can cause personal injury. 107.2

Factory Authorized Service Centers

Factory authorized service centers are located throughout the continental United States to provide maintenance, repair, and testing services for Kyle reclosers. For further information, contact your Cooper Power Systems sales representative.

Factory Maintenance Classes

The factory Service Department offers recloser maintenance training classes. These classes, taught by experienced service technicians, are held at the factory's in-house training facility. For additional information, contact your Cooper Power Systems sales representative.

Instructional Video Cassette Program

A video cassette maintenance training program; *KSPV1 General Maintenance and Inspection Procedures for Kyle Reclosers* is available as a supplemental training aid for maintenance personnel. This video program, developed for use in the factory training classes, is to be used in conjunction with existing service literature. For additional information, contact your Cooper Power Systems sales representative.



SERVICE PARTS LISTS

The service parts and hardware listed and illustrated include only those parts and assemblies usually furnished for repair or involve in the maintenance procedures described in this manual. Further breakdown of listed assemblies is not recommended.

Dimensions of all common hardware parts have been carefully checked so that they may be locally acquired. The suffix letter of the 14 character catalog number for common hardware parts codes the plating of the part.

A – No plating; raw material

H – Silver

M – Black oxide

Q – Cadmium + zinc + chromate

Y – Zinc + chromate

Z – Electro zinc + bronze irridite

A hardware kit, Catalog No. KA849R1, contains an assortment of roll pins, cotter pins, retaining rings, stop nuts, etc. – common hardware parts used in Cooper Power Systems reclosers that may not be readily available locally.

To assure correct receipt of any part order, always include recloser type and serial number. Because of Cooper Power Systems continuous improvement policy, there may be instances where the parts furnished may not look exactly the same as the parts ordered. However, they will be completely interchangeable without any rework of the recloser.

Prices of Replacement Parts, Section S280-01, lists recommended spare parts and prices for most parts. Parts not listed in price list may still be available. Consult your Cooper Power Systems sales representative for price and availability.

* This was previously a vented dipstick applicable to the following VXE reclosers:

- VXE15 Serial No. 10695 through 11008
- VXE27 Serial No. 787 through 1947

Dipstick (Item 17), pipe plug (Item 19), and pressure relief valve (Item 20) replace vented dipstick and pipe plug.

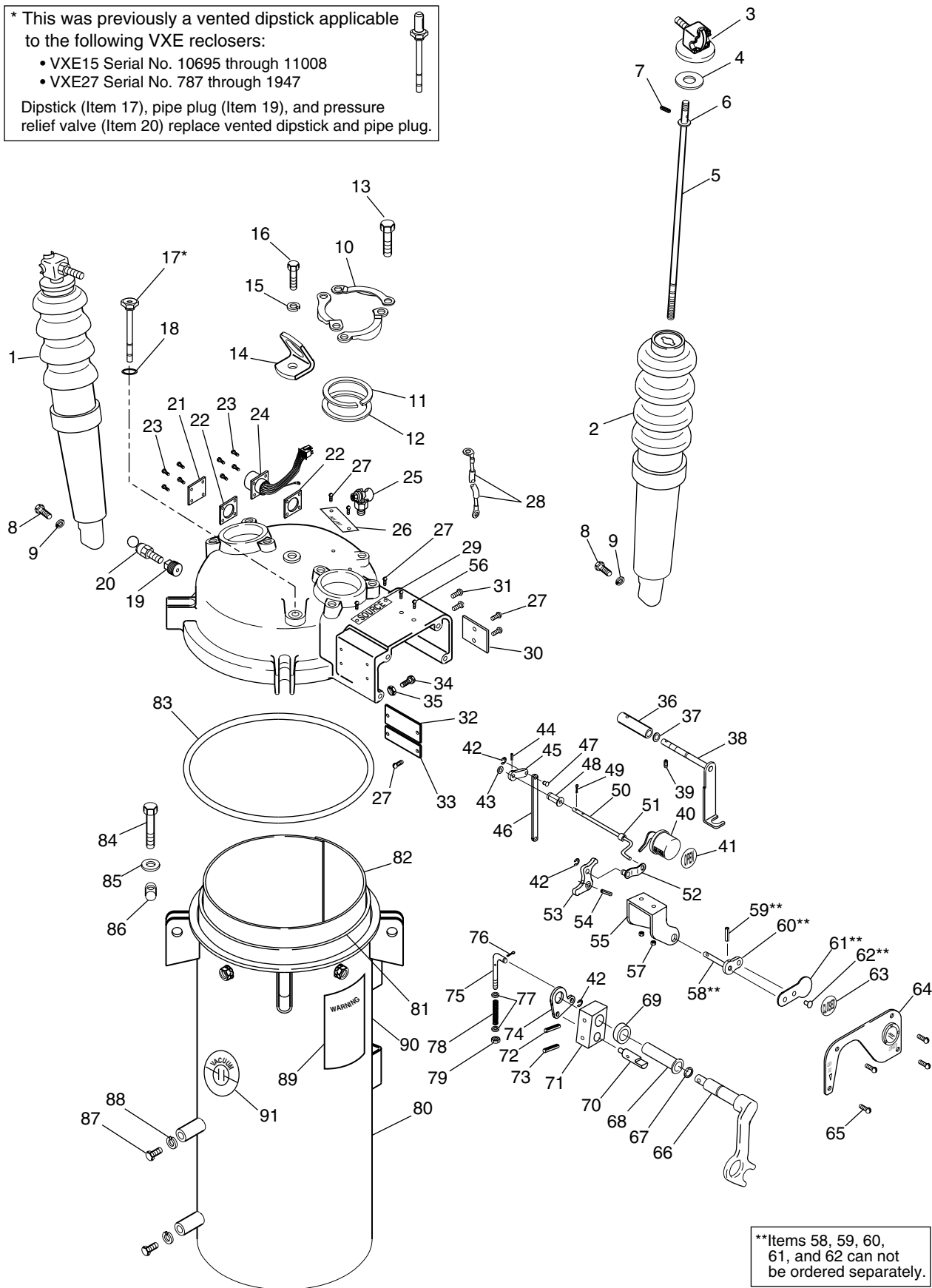

Figure 23.
Head and Tank. Applicable to VXE15 Serial No. 11009 and above and VXE27 Serial No. 1948 and above.



Head and Tank (Figure 23).

Item No.	Description	Catalog Number	Qty. per Assy	Item No.	Description	Catalog Number	Qty. per Assy
1	Bushing Assy.			37	O-Ring	KP2000A2	1
	VXE15, standard	KA160E26	2	38	One Shot Lever Assy	KVXE-153	1
	VXE27, standard	KA160E3	2	39	Set Screw	KP2023A6	1
	VXE15, 17 in creepage	KA160E27	2	40	Counter Assy	KA28CO14S	1
	VXE27, 26.5 in creepage	KA160E19	2	41	Decal (OPEN)	KVXE-1132	1
2	Bushing, ceramic			42	C-Ring	K970901188000M	3
	VXE15, standard	KP1L	1	43	Washer	K900525020043A	1
	VXE15, 17 in creepage	KP1L	1	44	Roll Pin	K970815093050A	1
3	Terminal	KA143L900	1	45	Lever	KVXE-1124	1
4	Upper Gasket	KP2090A57	1	46	Link	KVXE-1126	1
5	Rod			47	Pin	KP3190A12	1
	VXE15, standard	KP2403R6	1	48	Bushing Assy	KVXE-212-1	1
	VXE15, 17 in creepage	KP2403R6	1	49	Cotter Pin	K970525093050A	1
6	Washer			50	Counter Shaft	KVXE-1123	1
	VXE15, standard	KP2028A40	1	51	Spacer	KP3006A30	1
	VXE15, 17 in creepage	KP2028A40	1	52	Link Assembly	KVXE-176	1
7	Roll Pin			53	Lever	KVXE-1148	1
	VXE15, standard	K970801125075C	1	54	Groove Pin	KP2001A31	1
	VXE15, 17 in creepage	K970801125075C	1	55	Bracket	KVXE-1127	1
8	Screw, hex hd, 5/16-18 x 1 in	K730115131100A	2	56	Screw, rd hd, 6-32 x 7/16 in	K721515106043A	2
9	Lockwasher, 3/8	K900801031000Z	2	57	Stop nut, elastic, 6-32	KP2020A6	2
10	Bushing Clamp	KP117H6	6	58	Pin	KVXE-175 (Includes	1
11	Bushing Clamp Gasket	KP121L	2	59	Roll Pin	Items 58, 59, 60,	1
12	Lower Bushing Gasket	KP2090A29	2	60	Lever	61, and 62.)	1
13	Screw, hex hd 3/8-16 x 2 in	K730115137200A	6	61	Flag	Refer to Item 58.	1
14	Lifting Lug	KP473H1	1	62	Rivet	Refer to Item 58.	1
15	Lockwasher, 1/2 in	K900815050000A	1	63	Decal (CLOSED)	KVXE-1131	1
16	Screw, hex hd 1/2-13 x 1 in	K730115150100A	1	64	Sleethood Cover	KVXE-172	1
17	Dipstick	KVXE-624-1	1	65	Screw, rd hd,		
18	O-Ring	KP2000A6	1		Tap Type T #12 x 1/2 in	K781515112050A	4
19	Pipe Plug	KP2007A17	1	66	Operating Handle Assy	KA91L900	1
20	Pressure Relief Valve	KP0305040A35	1	67	O-Ring	KP2000A3	1
21	Plate	KP801ME1	1	68	Bushing	KP269L	1
22	Gasket	KP2379A1	2	69	Spacer	KP3013A100	1
23	Screw, slot hex washer hd			70	Stop Pin	KVXE-1059	1
	6-32 x 1/2 in	K999904250171A	8	71	Lever	KVXE-1058	1
24	Receptacle & Plug Assy	KVXE-134	1	72	Roll Pin, 3/16 x 3/4 in	K970801187075C	1
25	Ground Connector	KP701528A2	1	73	Roll Pin, 1/8 x 3/4 in	K970801125075C	1
26	Label, Ground Instruction	KP611D	1	74	Plate	KVXE-1057	1
27	Screw, rd hd, Tap Type F			75	Rod	KVXE-1089	1
	#2 x 3/16 in.	K751515102018A	8	76	Cotter Pin	K970525062050A	1
28	Ground Lead	KME4-131-4	1	77	Washer	K900525020043A	2
29	Label (Source)	KVXE-1101	1	78	Spring	KVXE-1151-1	1
30	Label (Non-Reclose)	KP390R	1	79	Stop Nut, Elastic	KP2020A1	1
31	Screw, rd hd, Tap Type F			80	Tank Assy	KA145L4	1
	6-32 x 5/8 in.	K751515106062A	2	81	Tank Wall Insulation	KP1082E4	1
32	Nameplate		1	82	Liner Assy	KVXE-1156	1
33	Coil Data Plate			83	Head Gasket	KP2103A4	1
	2.4 kV	KP567R1	1	84	Screw, hx hd, 1/2-13 x 3-1/4 in	K730115150325A	4
	4.16 to 4.8 kV	KP567R2	1	85	Washer	KP2028A19	4
	7.2 to 8.32 kV	KP567R3	1	86	Combination Nut & Pin	KP307L	4
	12.0 to 13.8 kV	KP567R4	1	87	Screw, soc hd, 3/8-16 x 3/4 in	KP2036A30	2
	14.4 kV	KP567R5	1	88	Lockwasher	K900815037000A	2
34	Screw, hex hd, 1/4-20 x 3/4 in	K730115125075A	1	89	Decal, Warning (Hazard. Volt.)	KSI1001	1
35	Palnut, 1/4-20	K881101120025Z	1	90	Decal, Warning (Solid Ground)	KSI1002	1
36	Sleeve	KVXE-1083	1	91	Decal, Warning (Vacuum)	KP1041V4H	1

Closing Coil Assembly (Figure 24).

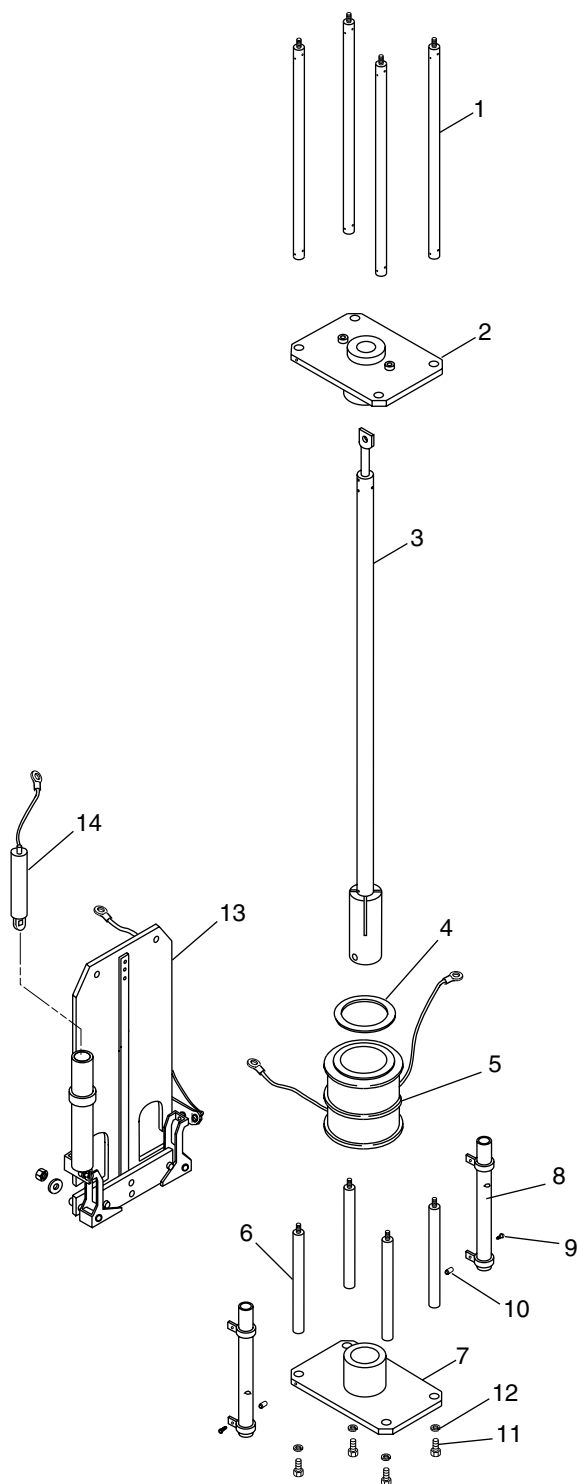

Item No.	Description	Catalog Number	Qty. per Assy
1	Stringer Assy	KVXE-122	4
2	Bridge Plate, Upper	KVXE-125	1
3	Plunger & Rod Assy	KVXE-124	1
4	Coil Gasket, Upper	KP389R	1
5	Coil Assy		
	VXE15, 2.4V	KVXE-703-1	1
	VXE15, 4.16-4.8V	KVXE-703-2	1
	VXE15, 6.0V	KVXE-703-3	1
	VXE15, 7.2-7.62V	KVXE-703-4	1
	VXE15, 8.0-8.32V	KVXE-703-5	1
	VXE27, 11.5V	KVXE-703-6	1
	VXE27, 12.0-13.2	KVXE-703-7	1
	VXE27, 14.4	KVXE-703-8	1
	Low-Voltage Closing, 125Vdc	KVXE-703-10	1
	Low-Voltage Closing, 250Vdc	KVXE-703-11	1
6	Stringer	KVXE-1038	4
7	Bridge Plate, Lower	KVXE-133	1
8	Insulating Tube	KVXE-1055	2
9	Screw, rd hd, 6-32 x 5/8 in	K721554106062A	4
10	Spacer	KP3006A43	4
11	Screw, hex hd, 3/8-16 x 1-1/4 in	K730101137125A	4
12	Lockwasher	K900801037000Z	4
13	Closing coil		
	Contactory Assy	KVXE-126	1
14	Fuse (per coil assy)		
	VXE15, 2.4kV	KA259R11	1
	VXE15, 4.16/4.8kV	KA259R12	1
	VXE15, 6.0kV	KA259R12	1
	VXE15, 7.2/7.62kV	KA259R13	1
	VXE15, 8.0/8.32kV	KA259R13	1
	VXE27, 11.5kV	KA259R13	1
	VXE27, 12.0/13.2kV	KA259R13	1
	VXE27, 14.4kV	KA259R13	1

Figure 24.
Closing Coil Assembly.

VXE Control (Figure 25).

Item No.	Description	Catalog Number	Qty. per Assy
1	VXE Control Circuit Board	KSEC-100-1	1
2	Timing plug		
	Curve A	KVXE-702-A	1
	Curve B	KVXE-702-B	1
	Curve C	KVXE-702-C	1
	Curve D	KVXE-702-D	1
	Curve E	KVXE-702-E	1
	Curve EF	KVXE-702-EF	1
	“FL” TCC	KVXE-702-FL	1
	Curve KF	KVXE-702-KF	1
	Curve N	KVXE-702-N	1
	Curve R	KVXE-702-R	1
	Curve TF	KVXE-702-TF	1
3	Battery and connector	KSEC-120	1
4	Control cable receptacle	KSEC-117	1
5	VXE Control nameplate		1
6	Decal, Ground Warning	KSI1002	1
7	Control cable	KVXEC7S	1

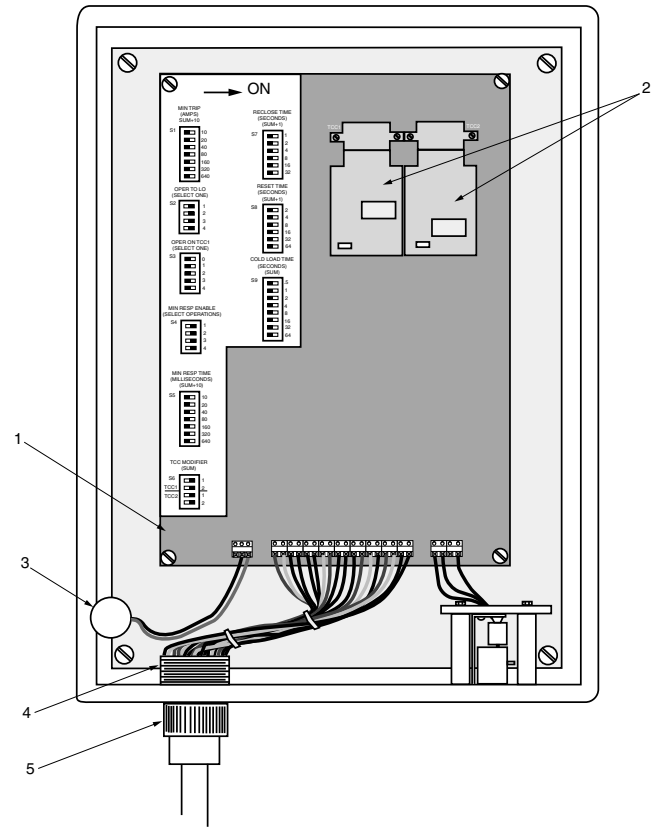

Figure 25.
VXE Control.



