

Reclosers

Form 6 Microprocessor-Based Yard Mount Recloser Control Installation and Operation Instructions

Service Information
S280-70-2

For Type F6-Y Control,
Serial Numbers 271 through 9999.



Figure 1.
Kyle® Form 6 Yard Mount Microprocessor-Based Recloser Control.

030004KM

Contents

Safety Information	2	Using Removable Inserts	29
Product Information	3	Accessories	30
Introduction	3	Control Cable	30
ANSI Standards	3	Front Panel with Expanded LEDs	30
Quality Standards	3	Discrete Interface Board Option Accessory	30
Acceptance and Initial Inspection	3	RS-232 Cable	30
Handling and Storage	3	120 Vac GFI Duplex Outlet	30
Control Power	3	Cable Locking Sleeves	30
Form 6 Recloser Control Description	4	Incoming Power Receptacles	30
Description	4	Stainless Steel Cabinet	30
Theory of Operation	4	Fiber Optic Interface Accessory	31
Control Front Panel	5	Low Voltage Closing	31
Control Features	10	BCT Terminal Blocks Accessory	34
Communications	13	Auxiliary Terminal Block Accessory	34
Control Information	13	Testing	35
Control Back Panel	13	Testing an Installed Control	35
Installation Procedure	14	Remove the Control from Service	35
Initial Programming Prior to Installation	14	Testing with Type MET Tester	36
Control / Recloser Compatibility	14	Closing the Recloser During Testing	36
Duty Cycle Monitor	15	Return the Control to Service	39
Mounting the Control	16	Additional Information	40
Grounding the Control	17	Replacement Kits	40
Customer Connections for Dc Power and Ac Voltage Sensing	18	Factory-Authorized Service Centers	40
Before Placing Control and Recloser into Service	23	Factory Testing and Troubleshooting Classes	40



SAFETY FOR LIFE



Cooper Power Systems products meet or exceed all applicable industry standards relating to product safety. We actively promote safe practices in the use and maintenance of our products through our service literature, instructional training programs, and the continuous efforts of all Cooper Power Systems employees involved in product design, manufacture, marketing, and service.

We strongly urge that you always follow all locally approved safety procedures and safety instructions when working around high voltage lines and equipment and support our “Safety For Life” mission.

SAFETY INFORMATION

The instructions in this manual are not intended as a substitute for proper training or adequate experience in the safe operation of the equipment described. Only competent technicians who are familiar with this equipment should install, operate, and service it.

A competent technician has these qualifications:

- *Is thoroughly familiar with these instructions.*
- *Is trained in industry-accepted high- and low-voltage safe operating practices and procedures.*
- *Is trained and authorized to energize, de-energize, clear, and ground power distribution equipment.*
- *Is trained in the care and use of protective equipment such as flash clothing, safety glasses, face shield, hard hat, rubber gloves, hotstick, etc.*

Following is important safety information. For safe installation and operation of this equipment, be sure to read and understand all cautions and warnings.

Hazard Statement Definitions

This manual may contain four types of hazard statements:

! DANGER: Indicates an imminently hazardous situation which, if not avoided, will result in death or serious injury.

! WARNING: Indicates a potentially hazardous situation which, if not avoided, could result in death or serious injury.

! CAUTION: Indicates a potentially hazardous situation which, if not avoided, may result in minor or moderate injury.

CAUTION: Indicates a potentially hazardous situation which, if not avoided, may result in equipment damage only.

Safety Instructions

Following are general caution and warning statements that apply to this equipment. Additional statements, related to specific tasks and procedures, are located throughout the manual.

! DANGER: Hazardous voltage. Contact with hazardous voltage will cause death or severe personal injury. Follow all locally approved safety procedures when working around high and low voltage lines and equipment.

G103.3

! WARNING: Before installing, operating, maintaining, or testing this equipment, carefully read and understand the contents of this manual. Improper operation, handling, or maintenance can result in death, severe personal injury, and equipment damage.

G101.0

! WARNING: This equipment is not intended to protect human life. Follow all locally approved procedures and safety practices when installing or operating this equipment. Failure to comply can result in death, severe personal injury, and equipment damage.

G102.1

! WARNING: Power distribution equipment must be properly selected for the intended application. It must be installed and serviced by competent personnel who have been trained and understand proper safety procedures. These instructions are written for such personnel and are not a substitute for adequate training and experience in safety procedures. Failure to properly select, install, or maintain power distribution equipment can result in death, severe personal injury, and equipment damage.

G122.2



PRODUCT INFORMATION

Introduction

Service Information S280-70-2 provides installation and operation instructions for the Kyle® Form 6 microprocessor-based yard mount recloser control below serial number 10,000.

Refer to *Service Information S280-70-4 Kyle Form 6 Microprocessor-Based Recloser Control Programming Guide* for additional information.

Read This Manual First

Read and understand the contents of this manual and follow all locally approved procedures and safety practices before installing or operating this equipment.

Additional Information

These instructions cannot cover all details or variations in the equipment, procedures, or process described, nor provide directions for meeting every possible contingency during installation, operation, or maintenance. When additional information is desired to satisfy a problem not covered sufficiently for the user's purpose, contact your Cooper Power Systems sales representative.

ANSI Standards

Kyle reclosers are designed and tested in accordance with the following ANSI standards: C37.60 and C37.85 and ANSI Guide C37.61.

Quality Standards

The Quality System at the Cooper Power Systems Kyle Distribution Switchgear plant is certified to the ISO 9001 standard.

Acceptance and Initial Inspection

Each Form 6 recloser control is completely assembled, tested, and inspected at the factory. It is carefully calibrated, adjusted and in good condition when accepted by the carrier for shipment.

Upon receipt, inspect the carton for signs of damage. Unpack the control and inspect it thoroughly for damage incurred during shipment. If damage is discovered, file a claim with the carrier immediately.

Handling and Storage

Be careful during handling and storage of the control to minimize the possibility of damage. If the control is to be stored for any length of time prior to installation, provide a clean, dry storage area. If storage is in a humid atmosphere, make provisions to keep the control circuitry energized.

Control Power

All operating power is obtained from the substation battery bank. There are two power supply options available for the Form 6 recloser control. Examine the voltage decal on the back of the recloser control to verify the correct voltage rating.

The following power supply options are available and configured at the factory:

- 24 Vdc $\pm 20\%$
Burden 14 Watts
- 40 Vdc – 140 Vdc
Burden 14 Watts

Note: The 40 Vdc – 140 Vdc power supply is a universal power supply adaptable for either 48 Vdc or 125 Vdc substation batteries.

A 120/240 Vac thermostatically controlled heater for humidity control is included as standard.

Refer to the **Customer Connections for Dc Power and Ac Voltage Sensing** section of this manual for incoming power wiring illustrations for the Form 6 recloser control.

FORM 6 RECLOSER CONTROL DESCRIPTION

Description

The Kyle® Form 6 yard mount microprocessor-based recloser control includes extensive system protection functionality, including phase, ground, and negative sequence overcurrent protection, over/underfrequency, and voltage protection, directionality, sensitive ground fault, and sync check.

Analysis tools include fault locating, event recording, TCC Editor™ II, Idea Workbench™, and oscillography functions, including oscillography replay.

Metering functions include demand and instantaneous current on a per-phase basis, instantaneous voltage and power factor on a per-phase basis, and power (real, reactive, apparent).

The front panel LCD display is used to configure the operating settings for the control. It is also used to display metering, counter information, control parameters, reset alarms, and provide diagnostic information.

Control parameters can also be programmed via a personal computer connected to the control through the front panel RS-232 port. Control programming, interrogation, and operations are performed with Form 6 ProView™ interface software on a personal computer.

The ProView™ interface program software includes additional functions used to create and graphically display Time Current Curves and provide the Idea Workbench™ for configuring user-selected inputs and outputs, configurable event and alarm data, and selectable communication points for serial communication.

The control operates on 50 and 60 Hz systems.

The control can be configured, by the factory or by the user, for a wide variety of applications. If user requirements change, the control functions can be modified to meet the new requirements.

Theory of Operation

A functional block diagram of the Form 6 recloser control is shown in Figure 2. Current sensing is provided by three current transformers located in the recloser and interfaced to the Form 6 recloser control via control wiring. This wiring also supplies Trip, Close, and Recloser status, and connects to the Recloser Interface (RIF) module to provide isolation for reliable operation. Voltages for metering are connected to the analog input module.

Line current flowing through the recloser is converted by the CPU module to a digital signal suitable for metering and fault current calculations. Data sampling occurs at a rate of 64 times per cycle. The CPU contains a data acquisition section that uses the acquired samples to compute the fundamental currents and voltage for use in overcurrent, under/overvoltage, and under/overfrequency protection, as well as currents and voltages for metering functions. The current for overcurrent protection is calculated on a sub-cycle basis; it includes only the fundamental and DC component.

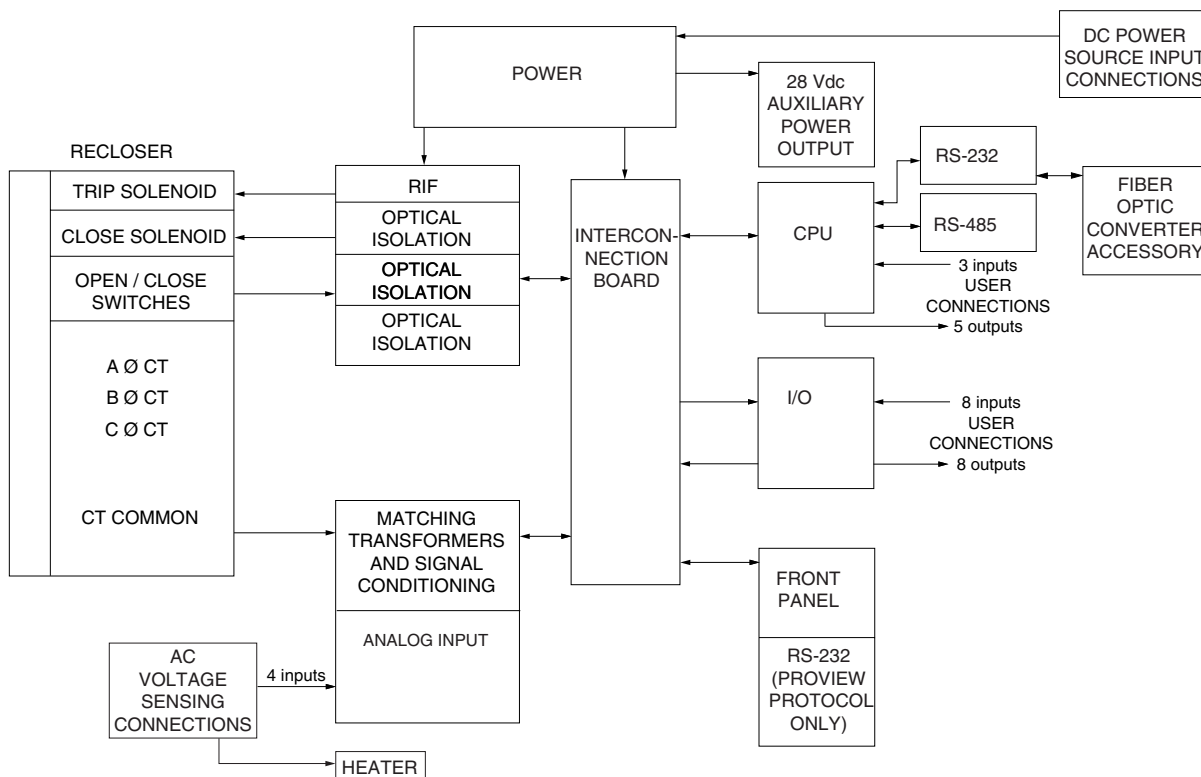

Figure 2.
Form 6 yard mount recloser control operational flow diagram.

When the phase or ground current exceeds its programmed minimum-trip value and associated time-current-curve (TCC) timing, the control initiates the programmed sequence of recloser tripping and reclosing operations via the CPU and RIF modules. If the fault is temporary, the control resets to the start of its operating sequence after a preset time delay. If the fault is permanent, the control performs its complete programmed sequence of reclose commands and locks out with the recloser open. Once locked out, the control must be closed via the operator panel or SCADA communications. This resets the control to the start of the operating sequence.

The following chain of events occurs for an operating sequence of two trips to lockout (one trip on TCC1, one trip on TCC2):

1. The overcurrent signal is integrated with time on the selected curve for the first trip operation (TCC1) to produce the signal which energizes the trip circuit.
2. Energizing the trip circuit connects the supply to the trip solenoid to open the recloser.

3. Upon opening, the control starts timing on the first reclosing interval-delay time.

4. Upon expiration of this reclosing interval-delay, a closing signal is issued from the control, closing the recloser, and selecting the time-current characteristics for the second trip operation (TCC2).

5. If current remains above the minimum-trip level, the recloser will trip on TCC2 and lockout the recloser.

Control Front Panel

The front panel is separated into two clearly identified, color-coded sections (Figure 3). The top portion of the front panel is used for programming the control and providing LED status indication. The lower portion of the front operating panel is used for operating the control and recloser.

Note: The control includes a Power Save feature that will turn off the backlit LCD display and all LEDs if no front panel keypad is pressed within five minutes. Pressing any key will reactivate the display and LEDs.

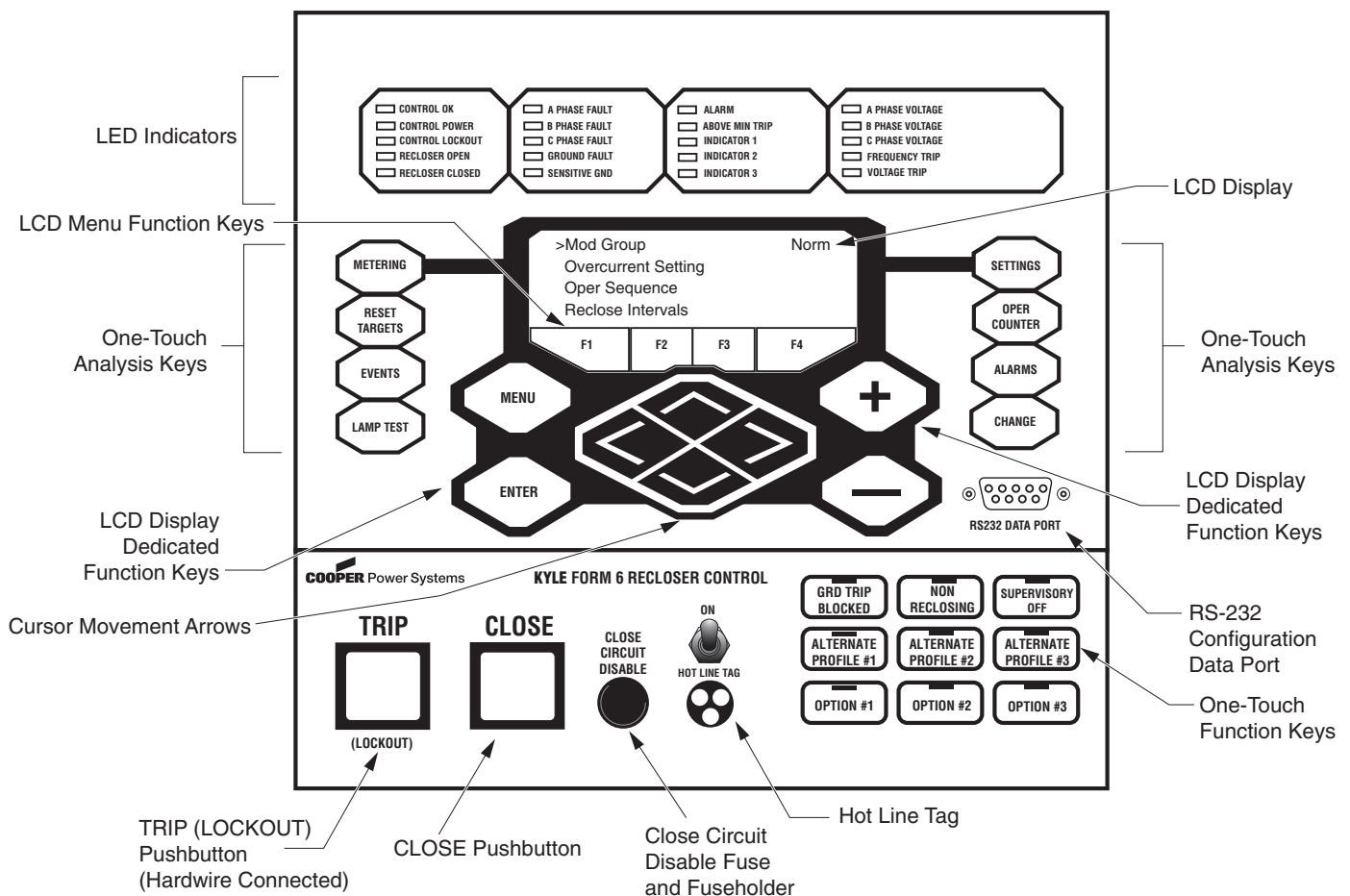

Figure 3.
Form 6 recloser control front panel.

Programming Panel

The Programming panel has the following sections:

One-Touch Analysis Keys

There are eight analysis keys (Figure 4) that allow one-button access to a variety of control and monitoring functions that appear in the LCD display. Pressing these buttons causes the following information to display or function to occur:

- **METERING:** Displays the systems instantaneous metering values for current and voltage on the LCD display.
- **RESET TARGETS:** Resets the fault target indicators on the operator panel.
- **EVENTS:** Displays the last 25 events from the Sequence of Events log.
- **LAMP TEST:** All operator panel LEDs are illuminated for verification of proper connection and operating status of all indicator lights. All status indicators will then return to their previous state. While in the LAMP TEST mode, the control response to operator panel keys is disabled, except for the TRIP (LOCKOUT), CLOSE, and HOT LINE TAG switches.
- **SETTINGS:** Displays recloser settings on the LCD display.
- **OPER COUNTER:** Displays the total number of trip operations and target counters for each A, B, and C Phase; Ground, and Sensitive Ground on the LCD display.
- **ALARMS:** Provides status information on the LCD display for all recloser alarms.
- **CHANGE:** Allows the user to change the state of the control functions on the operator panel function keys.

Note: The CHANGE mode is a ten second period in which one function setting can be changed. If no change is made in that time, the control returns to the current setting.

LCD Display

The LCD Display is a backlit 4-line, 20-character display that provides extensive distribution system, recloser, and control status information using a minimum of eight navigation keypads (Figure 4).

Note: The LCD display panel contrast is field-adjustable to allow for various mounting heights and applications. Press the MENU key and then press the (+) or (-) key to increase or decrease the contrast.

The four LCD navigation buttons are as follows:

MENU: Identifies the LCD Display menu options.

ENTER: Selects a menu option.

+ Increases value selection.

- Decreases value selection.

The four LCD menu function keys activate specific menu commands. When a command appears in the LCD display directly above one of the four LCD menu function keys, the user can press the key to accept/select the command.

The four LCD menu function keys are as follows:

F1

F2

F3

F4

The four cursor movement arrows allow movement in the following directions:

◀ Moves the cursor left.

▶ Moves the cursor right.

▲ Moves the cursor up one line.

▼ Moves the cursor down one line.

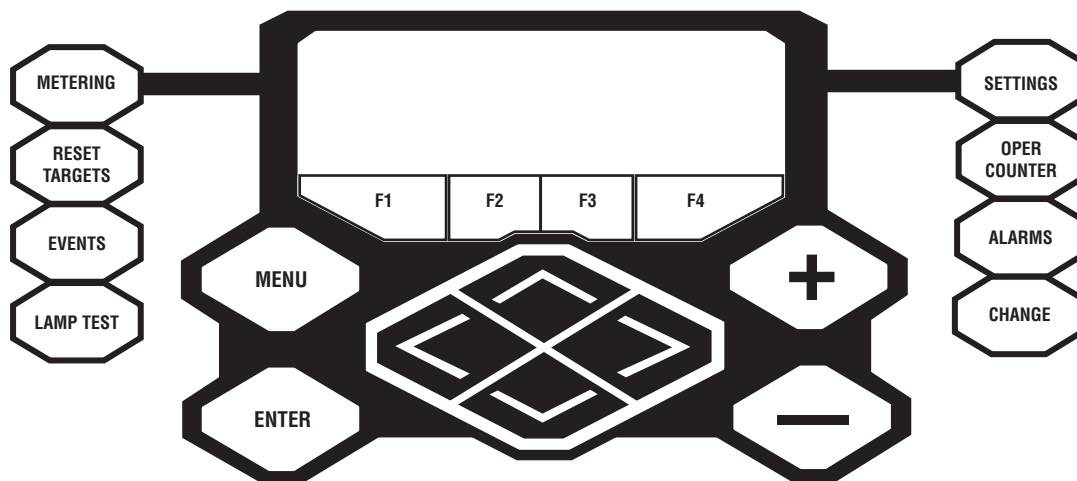

Figure 4. Analysis keys, LCD display, LCD menu function keys, and cursor movement arrows.

Status Indicator LEDs

The status indicator LEDs (Figure 5) in the Programming section of the Operator Panel give instant information on the control and recloser status:

CONTROL OK: The green LED indicates the control is operating normally and not in an alarm state. The CONTROL OK LED will not be illuminated during these alarms (indicated by the red ALARM LED and displayed in the alarm status log):

- **Memory Test:** This alarm indicates a failed ROM or RAM memory test.
- **Internal Power Failure:** This alarm indicates internal control operation power was outside of its operating tolerance for more than 20 seconds. This alarm resets when the internal control operation power returns to operation within its normal tolerances.

CONTROL POWER: The green LED indicates there is adequate charge (voltage) on the trip circuit capacitor to trip or close the recloser. This LED does not indicate the presence of AC or battery power.

CONTROL LOCKOUT: The green LED indicates the control is in a locked out state, i.e. a reclosing sequence is not in progress. This LED does not indicate that the recloser is open.

RECLOSER OPEN: The green LED indicates the recloser is in the open position.

RECLOSER CLOSED: The red LED indicates the recloser is in the closed position.

A PHASE FAULT, B PHASE FAULT, C PHASE FAULT: The red LEDs indicate A, B, and/or C phase current was either the maximum phase current or within 80% of the maximum when a trip signal was issued.

GROUND FAULT, SENSITIVE GROUND FAULT: The red LEDs indicate that a Ground and/or Sensitive Earth Fault tripping function was asserted at the time the trip signal was asserted.

ALARM: The red LED indicates an alarm has been issued. Review the alarm status and log on the LCD display for the specific alarm.

Note: If a Battery Alarm occurs, de-select the Pole Mounted Control checkbox in the ProView application software Configure>System Configuration dialog box. Refer to *S280-70-4 Form 6 Control Programming Guide* for additional information.

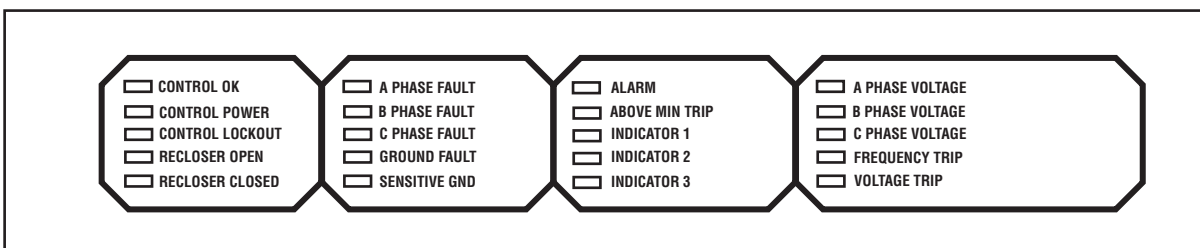

Figure 5.
Status indicator LEDs.

ABOVE MINIMUM TRIP: The red LED indicates the current exceeds the level set for minimum trip.

INDICATOR 1, INDICATOR 2, INDICATOR 3: Customizable LEDs that are used with functions programmed through the Idea Workbench™. The LED indicators do not have active default values. The LEDs are illuminated when the status configured via the Idea Workbench™ is present. These status indicators also include a user-customizable removable label insert. Refer to **Using Removable Inserts** for information on changing the labels in the removable insert.

A PHASE VOLTAGE, B PHASE VOLTAGE, C PHASE VOLTAGE: The red LED indicates a presence of voltage on the respective phases. The undervoltage phase pick-up setting controls the voltage indication for the front panel LEDs as defined in the Low Voltage Setting dialog box for the active setting profile. Refer to **Settings - Voltage** in the **Schemes** section of *S280-70-4 Form 6 Control Programming Guide*.

FREQUENCY TRIP: Indicates the recloser tripped due to a frequency trip.

VOLTAGE TRIP: Indicates the recloser tripped due to a voltage trip.

Operating Panel

The Operating section includes the following sections:

RS-232 Configuration Data Port

The RS-232 Connector (Figure 6) on the front operating panel allows direct connection to a personal computer without any special cables or connectors. This port is used only for configuring the control with ProView application software. All settings, metering, events, and oscillography data are available from this port. The port is Data Communication Equipment (DCE) wired for direct connection to a personal computer.

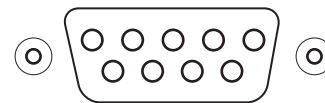

RS232 DATA PORT

Figure 6.
RS-232 configuration data port.

HOT LINE TAG ON/OFF Toggle Switch and LED Indicator

WARNING: Hazardous voltage. Do not use Hot Line Tag as a substitute for a visible disconnect. Always establish a visible disconnect prior to performing any work requiring a de-energized line. Failure to comply may cause death, severe personal injury, or equipment damage.

T276.0

Hot Line Tag is provided for live-line work applications. All closing operations are disabled when the Hot Line Tag feature is activated. While active, the control may also utilize an independent, user-selectable time-current curve for trip operations.

IMPORTANT: Hot Line Tag activation does not cause the recloser to trip open. It only prevents the recloser from closing.

IMPORTANT: Hot Line Tag is intended solely for live-line work applications, such as maintenance, repairs or improvements to the distribution system, that occur while the line remains energized.

Hot Line Tag prevents all closing attempts from the control and shifts protection to one trip-to-lockout on the composite curve of the Hot Line Tag definite time and the TCC1 curve (whichever is faster). Hot Line Tag takes precedence over Cold Load Pickup, Non-Reclosing, and Fast Trips Disabled.

Hot Line Tag is activated from either the operator panel toggle switch, serial communications, or a discrete SCADA function. All sources must be off to de-activate Hot Line Tag.

To activate the function from the operator panel, flip toggle switch up to the ON position. See Figure 7. The LED indicator illuminates when the function is active.

The Hot Line Tag function may only be reset by the source which initiates it. For example, if Hot Line Tag is activated at the operator panel, the reset function is only possible at the operator panel, and not via SCADA command.

CLOSE CIRCUIT DISABLE

Close Circuit Disable (Figure 7) is a removable fuse that, when removed from the front operating panel, disables the close circuit from the control to the recloser. Removing the cartridge from the control disables all electrical closing of the recloser and provides a physical disconnect to the recloser closing circuit. As a result, the control cannot perform a close operation. This disconnect overrides all close functions and makes a remote or manual close operation impossible.

Note: When the Close Circuit Disable fuse is removed, the trip circuit remains active and will trip per the programmed time current curve for a faulted condition.

IMPORTANT: If the CLOSE button is pressed after the Close Circuit Disable fuse is removed, do not reinstall the fuse until after the ALARM LED illuminates (within approximately five seconds) to indicate CLOSE MALFUNCTION. Re-installing the Close Circuit Disable fuse prior to the CLOSE MALFUNCTION ALARM indication will cause the control to close the recloser.

TRIP (Lockout) Pushbutton

The TRIP pushbutton (Figure 7) provides front-panel access to trip (lockout) the recloser. When pressed, the TRIP pushbutton opens the recloser and locks out the control. The TRIP pushbutton operates independent of the microprocessor and is directly connected to the trip coil in the recloser.

Note: In the event of main microprocessor failure, the trip circuit can operate independent of the main microprocessor.

CLOSE Pushbutton

When pressed, the CLOSE pushbutton (Figure 7) returns the control to the initial or home sequence position, closing the recloser. The control is ready for the start of a new trip/close sequence.

Note: Pressing the CLOSE pushbutton from the Lockout position initiates Cold Load Pickup (CLPU) protection, if the feature is enabled.

The user does have the ability to block COLD LOAD PICKUP through one of the user-configurable Option keys on the Operator Panel Function keypad (Figure 8). If the COLD LOAD PICKUP BLOCKED option button has been pushed, pressing the CLOSE pushbutton from the Lockout position will not initiate Cold Load Pickup Protection, even if the feature has been enabled from the interface software Protection Profile screen.

If the recloser is closed, pushing and holding the CLOSE pushbutton does not activate the Cold Load Pickup feature. See **Cold Load Pickup** in the **Control Features** section of this manual.

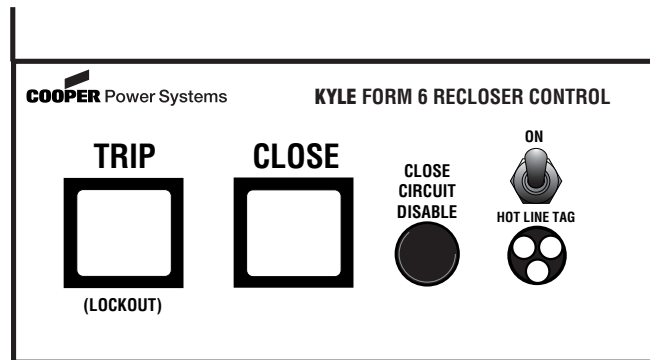

Figure 7. TRIP (Lockout) pushbutton; CLOSE pushbutton; Close Circuit Disable removable fuse; and Hot Line Tag switch and Hot Line Tag red indicator LEDs.

One-Touch Function Keys

Quick access to frequently operated Form 6 features is provided with nine function key pushbuttons on the control operator panel (Figure 8).

Red LEDs located on each function key indicate the status of the function, regardless of local or remote activation. For example, if Ground Trip Blocked is activated from a SCADA signal, the red indicator will illuminate even though it was not activated from the operator panel.

Operator panel function key activation or de-activation requires the operator to first press the CHANGE key to enter the CHANGE mode. A function must then be selected or de-selected within ten seconds to activate or de-activate the function. Once selected, the control returns to normal operation until prompted for another change request. This prevents accidental changing of functions or features.

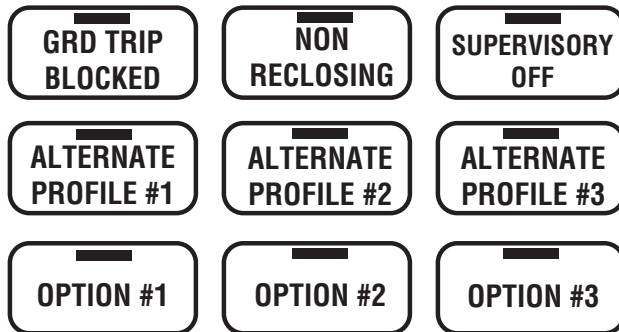

Figure 8.
Operator panel function keys.

GRD TRIP BLOCKED

The Ground Trip Blocked function blocks all ground sensing in the control for the active profile. This red indicator is illuminated when Ground Trip Block is activated from the serial port, I/O, the interface software, or locally (via the front panel) causing the control to block all ground sensing.

NON RECLOSING

The control is operating in a non-reclosing mode when the NON RECLOSING red indicator is illuminated. Non-reclosing mode disables any automatic reclosing operations. Non-reclosing does not alter the active TCC. Activation is possible from the SCADA port, I/O, the interface software, or locally (via the front panel).

SUPERVISORY OFF

When the SUPERVISORY OFF red indicator is illuminated, supervisory commands are blocked. Supervisory functions through the back panel serial communication ports and the discrete I/O are blocked. Serial communications through the front panel RS-232 port remain active independent of the status of the SUPERVISORY OFF switch. Activation of this function key is restricted to the operator panel and is accomplished by pressing the CHANGE key and then pressing the SUPERVISORY OFF key. Operational data and metering information are available while the control is in the SUPERVISORY OFF position. The TRIP and CLOSE pushbuttons and Hot Line Tag are active independent of the SUPERVISORY OFF function.

ALTERNATE PROFILE #1, #2, and #3

The Form 6 has four separate protection profiles; a Normal profile, and Alternate Profiles 1, 2, and 3. Each profile changes all protection parameters for the control. Except for the normal profile, each has an indication and selection key. When the operator panel display lights are active and none of the three indicators are on, the normal profile is active. Only one profile can be active.

To select an alternate profile, press the CHANGE key and then press the desired alternate profile.

To return to the normal profile, press the CHANGE key and then press the active alternate profile to deselect it. These functions can also be completed remotely via communications interfaces.

IMPORTANT: Unused alternate profiles should be programmed with the same settings as one of the applicable profiles. Default settings on unused alternate profiles can cause unnecessary outages if they are below normal system requirements.

IMPORTANT: Check minimum trip values prior to changing an alternate profile to avoid misoperation of the control under load conditions.

OPTION #1, OPTION #2, AND OPTION #3

There are nine additional functions available to program as Option #1, Option #2, or Option #3 function keys. Any three of these nine functions can become an option on the operator panel function key pad. The available functions are as follows:

- *Sensitive Earth Fault Enable:* Allows activation of Sensitive Earth Fault protection with a minimum sensitivity of 0.5 Amps selectable in 0.1 Amp increments.
- *Cold Load Pickup Blocked:* For applications where no loss of diversity occurs.
- *Sequence Coordination Disable:* Disables sequence Coordination for testing purposes.
- *Fast Trip Blocked:* Disables tripping on TCC1; trips on TCC2 time setting for total operating sequence.
- *Underfrequency Trips Enable:* Activates underfrequency protection pickup and time-delay settings.
- *Overfrequency Trips Enable:* Activates the overfrequency pickup and time-delay settings.
- *Single-Phase Undervoltage Trips Enable:* Activates the single-phase *only* undervoltage pickup and time-delay settings.
- *Three-Phase Undervoltage Trips Enable:* Activates the three-phase *only* undervoltage pickup and time-delay settings.
- *Overvoltage Trips Enable:* Activates *both* single- and three-phase overvoltage pickup and time-delay settings.

The OPTION #1, OPTION #2, and OPTION #3 function keys must be programmed via the Idea Workbench™. The options do not have active default values. The option LEDs are illuminated when the options configured via the Idea Workbench™ are selected. These function keys also include a user-customizable removable label insert. Refer to **Using Removable Inserts** for information on changing the labels in the removable insert.

Note: The OPTION #1, OPTION #2, and OPTION #3 function keys are intentionally not defaulted to any function. The functions are assigned to each OPTION key via the Idea Workbench™ application.

Control Features

The Form 6 recloser control offers numerous standard features and accessories that allow the user the utmost flexibility applying the recloser control.

Control Security

The Form 6 recloser control has multiple customer-programmable security codes to limit control programming and viewing function access to authorized personnel. The front panel Human-Machine Interface (HMI) includes a user-selected security code to access the settings. Plus, the ProView™ interface software has its own security levels for multiple-user access.

Refer to *Service Information S280-70-4 Kyle Form 6 Microprocessor-Based Recloser Control Programming Guide* for additional information.

Protection Profiles

Four protection profiles capable of fully specifying control operation are standard in the control. Each protection profile includes the following as a minimum:

- Overcurrent Protection
- Over/Undervoltage Protection
- Over/Underfrequency Protection
- Directional Protection
- Hot Line Tag Functionality
- Sync Check
- Sensitive Earth Fault Protection
- Sequence Coordination
- Operation Settings

Time Current Curves

Time-current curves are available for numerous functions, including fast and delayed operations for phase, ground, and negative sequence protection. Each time-current is selected from a defined fifty curves which can be further customized by the user. The time-current curves are also selected from a graphical TCC Editor™ II to visualize any modifications prior to configuring the control.

The time-current curves include the following modifications for phase, ground, and negative sequence protection:

- Time Multiplier with a range of 0.1 to 25 in .1 increments.
- Time Adder with a range of 0 to 30 seconds in .01 second increments.
- Minimum Response Time with a range of 0.1 to 1 seconds in .001 second increments.
- High Current Trip multiplier with a range of 1 to 32 multipliers in increments of 0.1.
- High Current Trip Time Delay with a range of .016 to .150 second in .001 second increments.
- Time Dial Reset co-efficient with a range of .1 to 30 seconds in 1 second increments.

Sequence Coordination

Sequence Coordination eliminates nuisance tripping through trip coordination. It allows the control to step through selected operations in the operating sequence without tripping. The number of Sequence Coordination advances is programmable from one to three operations to provide trip coordination with a downline recloser. This feature is independently selectable for each protection profile.

Cold Load Pickup

The control includes a Cold Load Pickup feature to prevent the control from tripping while energizing non-fault system loads. This feature has independently programmable minimum trip value time-current curve, reclose interval, and number of independent operations to lockout for each protection profile. Cold Load Pickup also includes TCC Multipliers, TCC Adders, Minimum Response Time, Time Dial Reset, and High Current Lockout. Also, direct values, not multiples of minimum trip, are provided for high current lockout.

Fast Trips Disabled

The control includes a Fast Trips Disabled feature to modify protection, so that all trip operations use the programmed TCC2. This feature is independently selectable for each protection profile. All trip operations will time on TCC2. Typically, TCC1 is fast and TCC2 is delayed. As an example, the control will change its sequence from 2 fast and 2 delayed operations to 2 operations on TCC2 when Fast Trips Disabled is active.

High Current Lockout

The High Current Lockout feature will automatically lockout the control on the selected operation when current exceeds a programmable level. The active trip numbers for the lockout is selectable for phase, ground, and negative sequence. This feature is independently selectable for each protection profile.

Sensitive Ground/Earth Fault Operation

The control has a Sensitive Ground/Earth Fault Trip feature that provides tripping of the recloser after a programmable, definite time for ground currents below normal ground minimum trip levels. The feature has programmable operations to lockout and reclose intervals independent of the ground settings. This feature is independently selectable for each protection profile.

Thermostatically Controlled Heater

The control includes a standard 15 (120 Vac) / 30 (240 Vac) Watt thermostatically controlled heater (ON at 70°F on falling temperature, OFF at 85°F on rising temperature) powered from 120 or 240 Vac input power. The heater is used for humidity control.

Metering

The control provides instantaneous and/or demand metering with programmable integration intervals for the following functions:

- Real and reactive power for each phase and total, including directional, on an individual phase basis.
- Demand currents on a per phase basis.
- Instantaneous currents, including ground current.
- Instantaneous voltage on a per phase basis.
- Instantaneous frequency.
- Positive, negative, and zero sequence voltages.
- Instantaneous power factor on a per phase basis.
- Metering settings to include demand interval, and alarm thresholds for current, single-phase kW, three-phase kW, single-phase kVAr, and three-phase kVAr.

Event Recorder

The Form 6 contains capabilities to perform Sequence of Events time-stamping for up to 33 event types. Sixteen additional events can be user-defined through the Idea Workbench™.

Factory-defined event types include:

- Overcurrent Protection Trip
- External Trip
- Non-Reclose Trip
- External Close
- Lockout
- Reset

The Event Recorder maintains a minimum of 90 event records. The last 25 events are viewable on the front panel LCD display. Refer to *S280-70-4 Form 6 Control Programming Guide* for additional information.

Recloser Duty Monitor

The Form 6 recloser control software is equipped with a Recloser Interrupting Duty Monitor. The Duty Monitor accumulates the summation of $I^{1.5}$ for all interrupted currents on each interrupter. This feature permits programmable entries to preset the duty of an existing recloser. The recloser duty monitor displays interrupting duty in percent of duty used. If the duty cycle monitor exceeds 100%, the recloser should be examined for maintenance.

Discrete SCADA Communications

The control provides five configurable output status contacts and three configurable input control contacts as standard. Each status contact is configurable using graphical interface software to combine status functionality along with Boolean algebra. Default output status contacts are: Lockout, Recloser Open, Recloser Closed, Ground Trip Block, and Hot Line Tag. One output status contact is a solid state output (SS1) with a pickup time no longer than two milliseconds.

The control also provides a minimum of three configurable input control contacts. Each control contact is configurable using a graphical interface software. Contacts accept a whetting voltage range of 12–48 Vdc or 48–125 Vdc, 120 Vac based upon the option selected at time of order. Each digital input is configured for either a momentary, maintained, or maintained with precedence contact. Default input control contacts are Supervisory Trip and Lockout, Supervisory Close, and Remote Trip and Lockout.

A Discrete Interface Board is also available as an accessory to provide an additional eight output status contacts and eight input control contacts. The expansion I/O board is completely user-configurable.

TCC Editor™ II

Coordination and actual time current modifications are available with a graphic interactive TCC Editor™ or similar graphical software.

The TCC Editor™ II includes a complete database of standard recloser industry time current curves (TCC), both ANSI and IEC types, along with the ability to customize the TCCs with multipliers, constant time adders, or minimum response time adders. Also, the user is able to derive their own specific TCC through data point entry. Each modified time current curve can be identified with a user-customized name and is selectable for configuring the control. The grid and format for presenting the TCCs has a user-adjustable scale, including the option of presenting multiple TCCs in various user-configured colors.

Oscillography

Oscillography is provided to present current and voltage waveforms, along with protection element and recloser response status changes. Filtered and unfiltered data are provided for viewing.

The recorded values are super-imposed on the protection scheme, and the state or value at any point in the scheme is displayed. The user has the capability to move through the event and watch the response of every function. All analog signals, digital inputs, and contact outputs are monitored. Analog oscillography is displayed at 16 samples per cycle.

Oscillographic data is recorded to analyze multiple events during a permanent fault or other event type. The oscillographic data shows two cycles before the trigger point and eight cycles after the trigger point (default).

Note: The configuration settings are programmable.

Oscillography automatically initiates trigger points for the following functions:

- Above Minimum Trip for Phase, Ground, and Sensitive Ground Fault
- Single- and Three-Phase Overvoltage
- Single- and Three-Phase Undervoltage
- Over- and Underfrequency
- Trip Signal Issued
- Close Signal Issued

Removable Inserts

Removable inserts are included with the control design for customization of specific protection requirements. Inserts are available for the status indicator LEDs, the operator panel function keys, and the analysis keys. The removable inserts are designed for use without adhesives, labelmakers, or temporary labels. Refer to **Using Removable Inserts** in this manual for more information.

An electronic label template is included on the ProView™ application software CD and can be accessed through the following default address:

C:/Program Files/Cooper/Proview40/Form6/Form 6 Inserts.doc

Idea Workbench™

The Idea Workbench™ provides access to various inputs, intermediate variables, and internal Form 6 alarms, status, and targets to allow user-customization of the Form 6 recloser control to meet specific and unique applications. The Idea Workbench™ also gives the user the ability to perform logical functions with these variables by using a simple graphical user interface. Refer to *Service Information S280-70-4 Form 6 Microprocessor-Based Recloser Control Programming Guide* for additional Idea Workbench™ information.

Over/Underfrequency Protection

The control includes two-stage operation for both underfrequency and overfrequency protection. A fixed time delay ranging from 0 to 100 seconds in .001 second increments is available for both over and underfrequency. A frequency restoration function, enabled or disabled by the user, is provided to allow the recloser to automatically close should frequency return to within configured settings for a user-settable time. Over/Underfrequency protection is included as part of each protection profile.

Over/Undervoltage Protection

The control includes single-phase and three-phase undervoltage tripping. The control also includes three-phase overvoltage tripping. Both over and undervoltage functions include a single-phase and three-phase pick-up setting; a single-phase and three-phase time delay setting ranging from 0 to 100 seconds.

Directional

Directional functionality is included to maintain system coordination from multiple sources, as well as circuit reconfiguration for each profile. Directional applies to phase, ground, and negative sequence protection, selected independently. A maximum torque angle has a range of 0 – 90 degrees.

Data Profiler

A fully-configurable data profiler is available which allows the user to collect information by sampling data at selectable intervals. These time-stamped values can then be viewed to determine weekly load profiles, daily harmonic disturbances or hourly voltage fluctuations. The number of days of information the data profiler can provide

depends upon configuration parameters. Refer to *Service Information S280-70-4 Form 6 Microprocessor-Based Recloser Control Programming Guide* for additional information.

Fault Location

The control includes an impedance-based fault locator based upon the Takagi algorithm¹. Load-compensated impedance calculation is used for calculating the distance. Positive and zero sequence is configured in ohms, and the fault locator line length is configured in kilometers/miles.

¹ T. Takagi, Y. Yamakoshi, J. Baba, K. Uemura, T. Sakaguchi, "A New Algorithm of an Accurate Fault Location for EHV/UHV Transmission Lines: Part I - Fourier Transformation Method", *IEEE Trans. on PAS*, Vol. PAS-100, No. 3, March 1981, pp 1316-1323.

Sync Check

Sync Check is a permissive system used to qualify any close signal to the mechanism when enabled via the sync check settings. Sync check allows for closing for any combination of dead/live bus/line, and to perform anticipatory closing for a live bus/live line condition by calculating slip and anticipating the mechanism closing delay. In addition to the anticipatory close calculation, the sync check system performs verification of line and bus voltage magnitudes and frequencies to determine that they are within pre-determined ranges, and that the angular difference between the two systems is also within the pre-determined range. For a live/live close, where there is no slip between the systems, the sync check system allows permissive closing after the two systems are within frequency and voltage limits, and the angular difference between the systems has been within the allowable limits for a pre-determined time.

Sync Check functionality includes the following applications: Hot Line/Hot Bus Closing; Dead Line/Hot Bus Closing; Hot Line/Dead Bus Closing; and Dead Line/Dead Bus Closing.

Sync Check Parameters include the following configurable settings: Voltage Angle; Mechanism Operating Delay; Static Angle Delay; Dead Threshold; Live Threshold; Positive Sequence Dead Threshold; Upper Voltage Limit; Lower Voltage Limit; Lower Frequency Limit; Upper Frequency Limit; and Fail to Close Timer.

Manual Close Delay

Manual Close Delay provides a delay from the time that the manual CLOSE button is pushed to the time the manual close operation is performed.

The delay is programmable from 0 to 60 seconds in 1 second increments. A programmed delay value can be overridden for immediate closing by pressing the CLOSE button a second time.

An active Manual Close Delay can be canceled by pressing the TRIP/LOCKOUT button.

The default setting has the feature disabled (0 seconds). A countdown on the front panel LCD screen indicates Manual Close Delay is active.

Communications

Communication Ports

The Form 6 recloser control has two user-accessible communication ports, plus a front panel configuration data port. The front panel configuration data port is described in the **Operating Panel** section of this manual.

There is one standard RS-232 and one RS-485 communication port on the back operator panel, as well as a standard IRIG-B port for user time-syncing. See Figure 10.

Communication Protocols

Four communication protocols are available for the Form 6 recloser control:

- Modbus
- DNP3
- 2179
- IEC870-5-101

One communication protocol can be selected for either the back panel RS-232 or RS-485 port.

These protocols are selected and configured by the user with the ProView™ Communications Workbench™ application software.

When Modbus, DNP3, IEC870, or 2179 communication protocol is selected for the RS-485 serial port, the RS-232 serial port is defaulted to ProView™ interface software protocol.

When Modbus, DNP3, IEC870, or 2179 communication protocol is selected for the RS-232 serial port, the RS-485 serial port is not active. The RS-485 serial port does

not support ProView™ interface software protocol. DNP3 is factory-defaulted to the RS-232 port.

The user can simultaneously communicate to the Form 6 control using both the front panel data port and the appropriate back panel serial communication port (provided the back panel RS-232 port is not configured to be ProView protocol).

Control Information

Control information includes firmware identification by catalog number and name, date code, and ProView release number. Control information is available through the Settings menu on the front panel (Figure 4).

Control Back Panel

The control back panel is easily accessible through the back door of the control cabinet (Figure 9) with readily identifiable communication ports and connections (Figure 10).

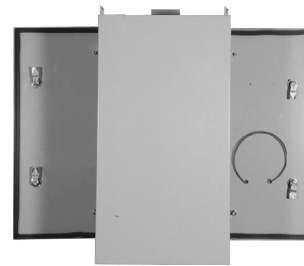

Figure 9. Form 6 yard mount recloser control is accessible from both the front and back of the cabinet.

030034KM

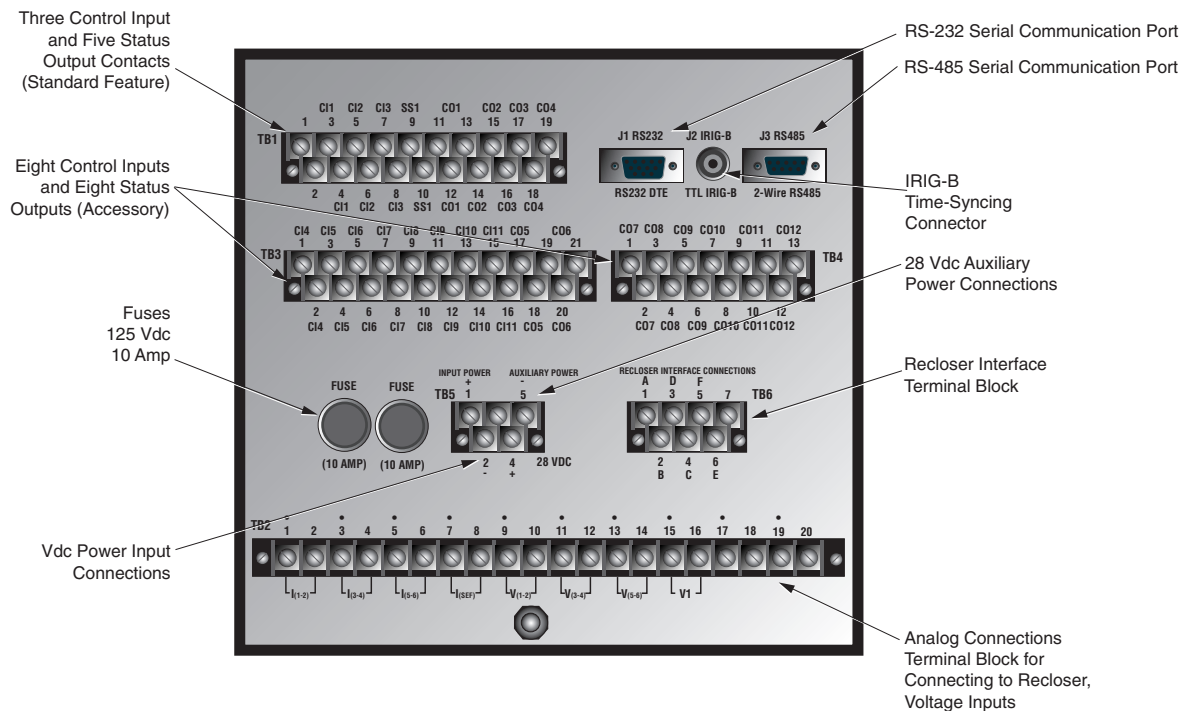

Figure 10. Form 6 yard mount recloser control back panel.

INSTALLATION PROCEDURE

Initial Programming Prior to Installation

CAUTION: Equipment misoperation. Do not connect this control to an energized recloser until all control settings have been properly programmed and verified. Refer to the programming information for this control. Failure to comply can result in control and recloser misoperation, equipment damage, and personal injury.

G110.3

The control must be programmed with all necessary operating settings, all alternate profiles, and parameters prior to operation with an energized recloser.

IMPORTANT: Program all protection profiles. Unused alternate profiles should be programmed with the same settings as one of the applicable profiles. Default settings on unused alternate profiles can cause unnecessary outages if they are below normal system requirements.

IMPORTANT: Check minimum trip values prior to setting or changing an alternate profile to avoid misoperation of the control under load conditions.

Note: Initial programming of the control is the responsibility of a qualified technician or engineer familiar with control functions and programming parameters required for the specific recloser installation.

The control must be programmed with the Form 6 ProView interface software. Refer to *Service Information S280-70-4 Kyle Form 6 Microprocessor-Based Recloser Control Programming Guide* for additional information.

Control / Recloser Compatibility

The Form 6 yard mount recloser control is adaptable to the following Kyle reclosers:

WE*, WVE27, WVE38X, VWE, VWVE27, VWVE38X, VSA12, VSA16, VSA20, VSA12B, VSA20A, VSO12, VSO16, Auxiliary-Powered NOVA15, and Auxiliary-Powered NOVA27

* This control is not compatible with Form 1 Type WE reclosers below s/n 300 and RE reclosers below s/n 400.

A control cable is required to connect the Form 6 yard mount recloser control to these reclosers. Refer to TABLE 3 in the **Recloser Connections/Control Cable** Section of the **Customer Connections for Dc Power and Ac Voltage Sensing** section of this manual.

Reclosers manufactured prior to June 1989 are equipped with Type A bushing current transformers. These reclosers were designed for use with Form 2, Form 3, and Form 3A controls. Because the Form 6 recloser control is designed for use with reclosers equipped with Type B current-sensing Transformers, reclosers retrofitted with Form 6 recloser controls should be retrofitted with Type B current transformers. All reclosers manufactured since

1989 are equipped with Type B (1000:1, 1000/500:1, or 2000:1) sensing CTs.

Reclosers equipped with Type B sensing CTs are compatible with all Kyle recloser controls (Form 2, Form 3, Form 3A, Form 4A, Form 4C, FXA, FXB Form 5, Form 5 LS/UDP, and Form 6 recloser controls), and are identified with the following label prominently displayed on the recloser sleet hood or the front of the operator cabinet:

NOTICE

RECLOSER IS EQUIPPED WITH TYPE B SENSING CTs.
RECLOSER DOES NOT HAVE A BATTERY CHARGER.

The Form 6 recloser control can be used with the old-style Type A CTs; however, the event recorder and duty cycle monitor will have limited accuracy for currents above 5000 Amps.

Retrofit kits with the new Type B sensing CTs are available to upgrade existing families of reclosers for operation with Form 6 recloser controls. For additional information, contact your Cooper Power Systems representative.

For identification, Table 1 lists the serial number breaks between old-style Type A and the new-style Type B sensing CTs. Below this serial number, the recloser is equipped with the Type A CTs.

Note: For reclosers shipped prior to June 1989 and not listed below, please contact your Cooper Power Systems representative with the recloser type and serial number for verification of type A or B bushing current transformers.

TABLE 1
Serial Number Break for Reclosers with Type A Sensing CTs

Recloser	Below Serial Number
RXE	5831
RVE	5894
WE	11199
WVE	3695
VWE	7199
VWVE27	7208
VWVE38	1204

All VSA reclosers are equipped with Type A Sensing CTs.
All VSML reclosers are equipped with Type A Sensing CTs.
All VSA12, VSA12B, VSA16, VSA20, VSA20A, and VSA20B reclosers are equipped with Type B Sensing CTs.
All VWVE38X and VWE38X reclosers are equipped with Type B Sensing CTs.



Duty Cycle Monitor

The Duty Cycle Monitor provides the following duty cycle information:

- Measures and records duty for each individual phase in non-volatile memory.
- The recloser duty is measured and stored on the basis of $Current^{1.5} \times Number\ of\ Operations\ for\ Each\ Phase$ (ANSI C37.61).
- Readout is based on a percentage of total duty cycle for each phase.
- Duty record can be adjusted or reset if recloser is changed-out, serviced, etc.

Using Table 2, select the appropriate recloser interrupting duty cycle factor and enter that value via the ProView™ interface software.

TABLE 2
Duty Cycle Factor

Recloser Type	Interrupting Rating (rms sym Amps)	100% Duty Cycle Factor*
RXE, RVE	6,000	97
WE	12,000 @ 4.8 kV	257
WE	10,000 @ 14.4 kV	196
VWE		
VWVE27	12,000	1045
VWVE38X		
WVE27	8,000	140
WVE38X	8,000	140
VSA12	12,000	1045
VSA16	16,000	1608
VSA20		
VSA20A	20,000	2248
VSA20B		
VSO12	12,000	1045
VSO16	16,000	1608
AC NOVA	12,500	1111

*Duty Cycle Factor is Value x 10⁵.

Mounting the Control

WARNING: This equipment is not intended to protect human life. Follow all locally approved procedures and safety practices when installing or operating this equipment. Failure to comply can result in death, severe personal injury, and equipment damage.

G102.1

Mount the Form 6 recloser control in a convenient, accessible location in a substation yard. Mounting dimensions are provided in Figure 11.

A hole and keyway in the control mounting bracket accommodates a 15.9 mm (5/8") bolt.

Limits on control cable lengths are determined by the recloser type and the distance between the control and recloser: See Table 3 for available Form 6 recloser control cable lengths for Kyle® reclosers.

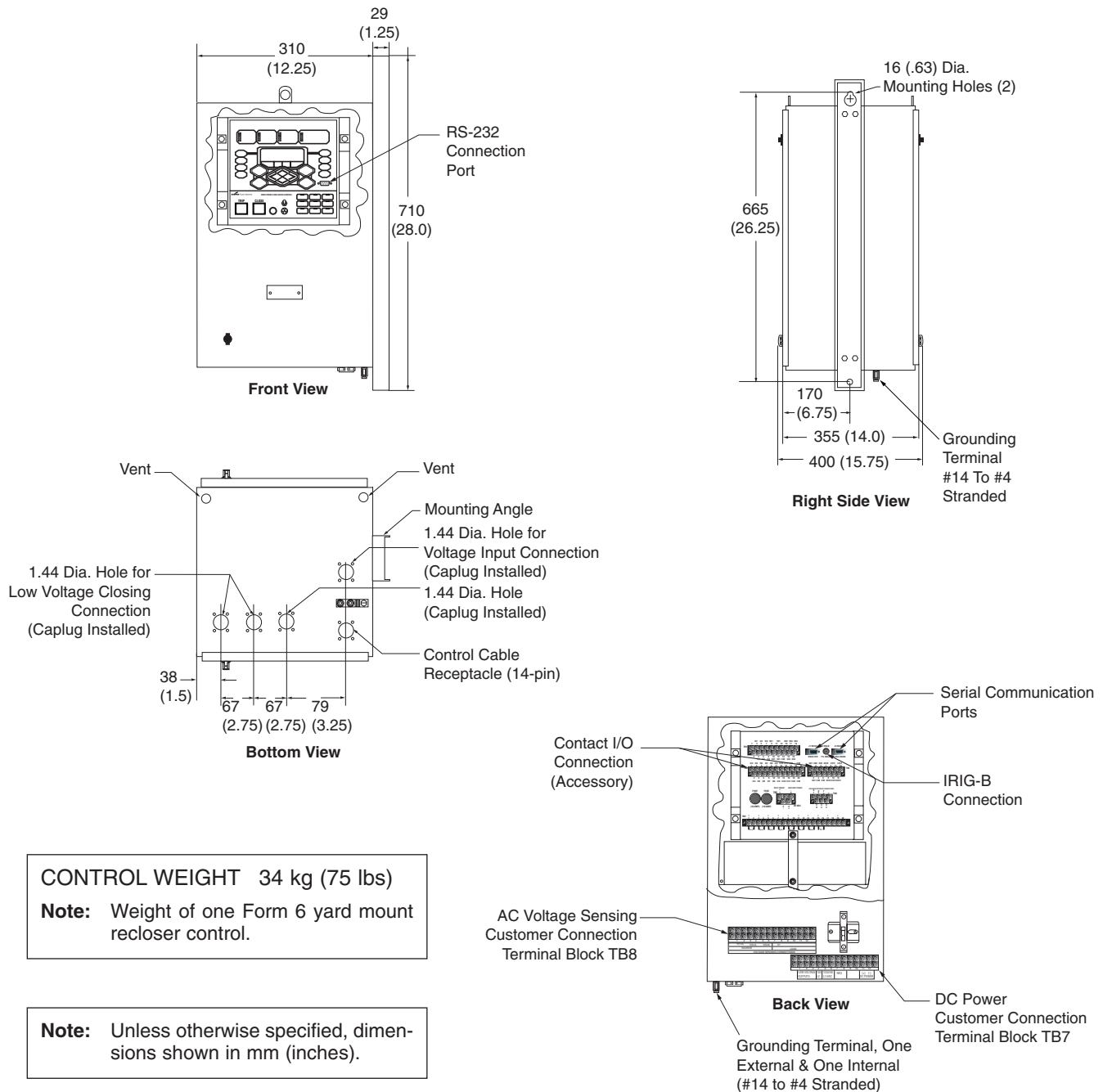

Figure 11.
Form 6 yard mount recloser control weight and dimensions.

Grounding the Control

WARNING: Hazardous voltage. Recloser and control must be solidly grounded. Follow all locally approved procedures and safety practices when grounding this equipment. Improper grounding can result in contact with high voltage, which will cause death or severe personal injury.

G115.1

The Form 6 yard mount recloser control must be solidly grounded prior to installation or energization. Refer to Figure 12 for grounding connections.

Note: Control grounding must comply with all locally approved procedures and safety practices that apply in a substation yard.

IMPORTANT: All external inputs to the Form 6 recloser control must be routed within 8 inches of their corresponding ground. During a surge, a potential of approximately 1.5 kV per foot can develop in the conductors. Differences between conductor and ground path lengths can add additional stress to the control components in the event of a power surge.

The control cabinet must be grounded. A grounding connector on the underside of the cabinet will accommodate No. 14 solid through No. 4 stranded conductors.

The recloser that the control will be connected to must also be properly grounded.

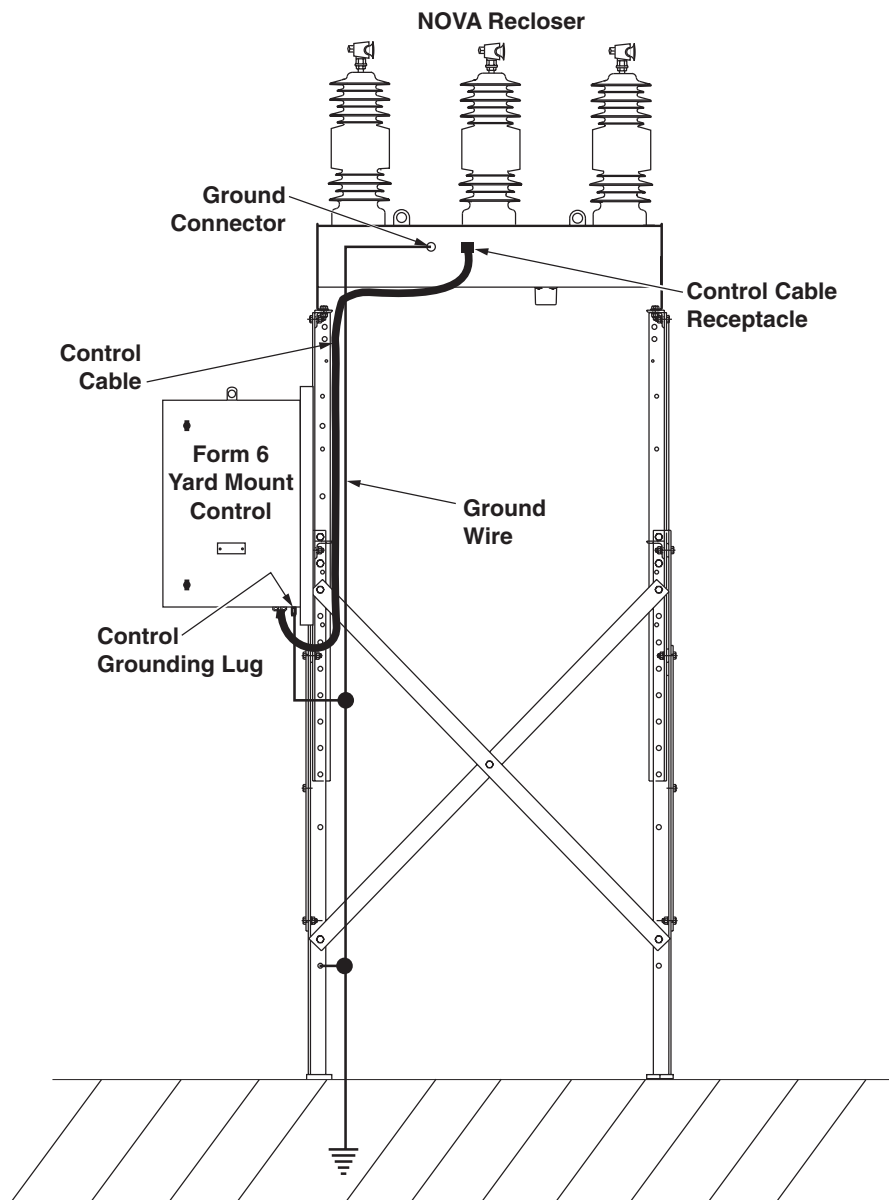

Figure 12.
Grounding connections for a Form 6 yard mount control installed in a substation.

Customer Connections for Dc Power and Ac Voltage Sensing

CAUTION: Equipment damage. Do not drill connection holes into the top of the cabinet. Connection holes in the top of the cabinet will allow moisture to seep into the control and damage the components or cause control misoperation. Failure to comply will void the control's factory warranty. T249.0

Dc Power

Input power to the Form 6 recloser control is connected to terminal block TB7 (Figure 13), which is located in the lower-right corner of the cabinet. Input dc power is required to power the control and recloser. The control requires dc station supply service for the main power requirements of both the control and the recloser.

The control requires the correct dc power supply for proper operation with the dc substation battery. The control has two power supply options based upon the following voltage ranges:

- 20 – 32 Vdc
- 40 – 140 Vdc

IMPORTANT: Verify the label on the Form 6 yard mount recloser control matches the voltage of the substation supply prior to installation.

Dc power is connected to terminal block TB7, terminal positions 11(+) and 12(-).

Note: The label at TB7-11 and TB7-12 will display the user-specified input power option (24 Vdc or 48/125 Vdc).

IMPORTANT: Substation battery negative is not grounded in the control.

The control should be grounded as discussed in the **Grounding the Control** section.

Ac Voltage Sensing

Ac power is required:

- To provide voltage and power metering
- For the low voltage closing accessory
- For the convenience outlet accessory
- To power the thermostatically controlled heater

Ac voltage input connections are connected to TB8 for Wye connections only. Figure 14 illustrates three-phase wiring connections for source side connections and single-phase wiring connections for load side connections.

Note: Three-phase wiring connections for load side connections are not available.

The ac voltage inputs for both source or load side accept a voltage input of 120/240 Vac nominal. For single-phase source side ac voltage inputs, connections to AØ, BØ, or CØ are acceptable.

Note: The default wiring is connected to BØ.

Terminal Blocks

Two terminal blocks are used for connection to the Form 6 recloser control. Both terminal blocks are fit for a #6 screw which can allow a maximum terminal size for a #10 AWG wire size.

Terminal Block TB7 provides dc power to the Form 6 recloser control and is directly connected to the power supply circuit board. TB7 is also used to provide ac voltage inputs for the heater and low voltage closing accessories. Terminal Block TB8 is used to connect sensing transformer voltage. The wiring of the transformers should follow the application illustrations per Figures 14 and 15. TB8 will accept a voltage input range of 90 – 265 Vac.

Default factory wiring includes connection of two wires from Power Supply Terminal Block TB7 to the Metering Terminal Block TB8. See Figure 16.

The wiring from TB7-5 to TB8-3 and from TB7-7 to TB8-4 connects the sensing B phase voltage. If the incoming sensing voltage is not the B phase voltage, the lead wire needs to be moved to the appropriate location. See Figure 18 for A phase connections.

For A phase voltage sensing only, connect to TB8-1.

For C phase voltage sensing only, connect to TB8-5.

Figure 17 shows customer connections to TB8, 120 Vac Delta connection.

For 240 Volt, 3-wire transformer connection refer to Figure 19.

Note: Terminal Block positions TB7-5 and TB7-6 are factory-jumpered together.

Terminal Block positions TB7-7 and TB7-8 are factory-jumpered together.

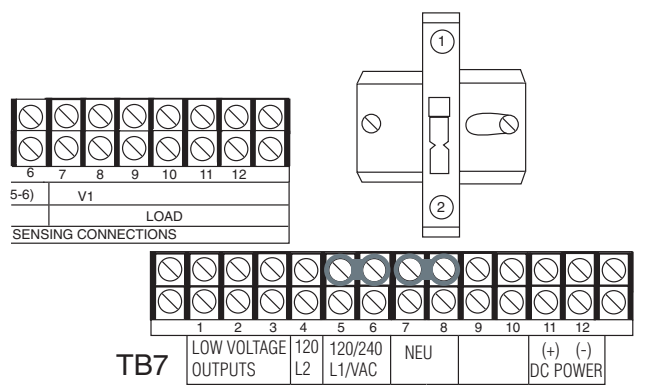

Figure 13.
Power Connections Terminal Block TB7.



Ac Power Requirements

The transformer required for power should be a minimum of 5 kVA for low-voltage ac closing reclosers and 1 kVA for high voltage ac closing reclosers.

Note: Ac voltage is required for the internal cabinet heater and the 120 Vac GFI Duplex Outlet accessory.

The following are not functional for single phase ac voltage input:

- Directional Protection
- Single-Phase Voltage Protection
- Three-Phase Metering
- Sync Check

Recloser Connections/Control Cable

 **WARNING:** Hazardous voltage. Recloser and control must be solidly grounded. Follow all locally approved procedures and safety practices when grounding this equipment. Improper grounding can result in contact with high voltage, which will cause death or severe personal injury. G115.1

Cooper Power Systems provides a control cable accessory (KA18ME). The control cable is fabricated with connectors which mate with the female receptacle of the recloser on one end, and the male receptacle of the control or junction box on the other end.

Several control cables are available based upon the recloser type and required distance between the recloser and control. Refer to Table 3 for available control cable lengths.

Note: The control cable must be supported along its length to prevent repeated movement due to wind or other outside forces which can damage the cable.

TABLE 3
Available Form 6 Recloser Yard Mount Control Cable Lengths for Kyle Reclosers

Recloser Type	Gauge	Length	
		Meters	Feet
WE, WVE27, WVE38X, VWE, VWVE27, VWVE38X, Auxiliary-Powered NOVA15, Auxiliary-Powered NOVA27	16	1.5 to 24	5 to 80
	18	1.5 to 12	5 to 40
VSA12, VSA12B, VSA16, VSA20, VSA20A, VSO12, VSO16	16	1.5 to 7.5	5 to 25
	18	1.5 to 3	5 to 10

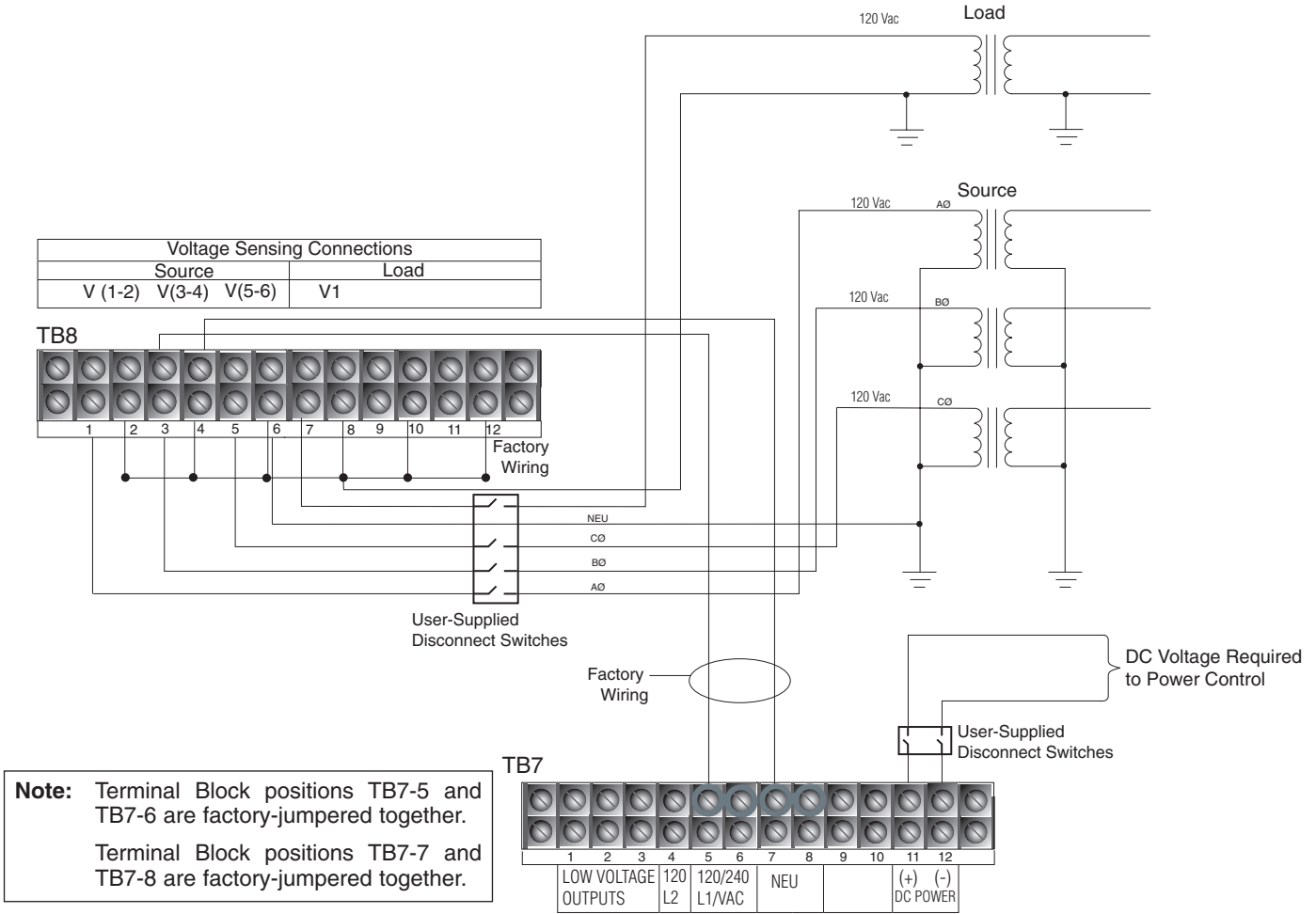

Figure 14.
Three-Phase Transformer Connection for Voltage Sensing and Heater, Wye configuration only (TB8 Terminal Block Connection).

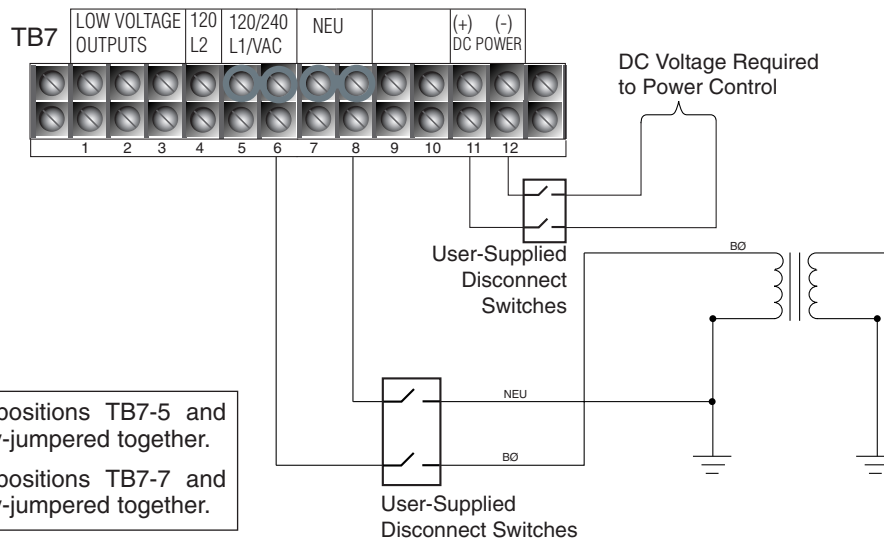
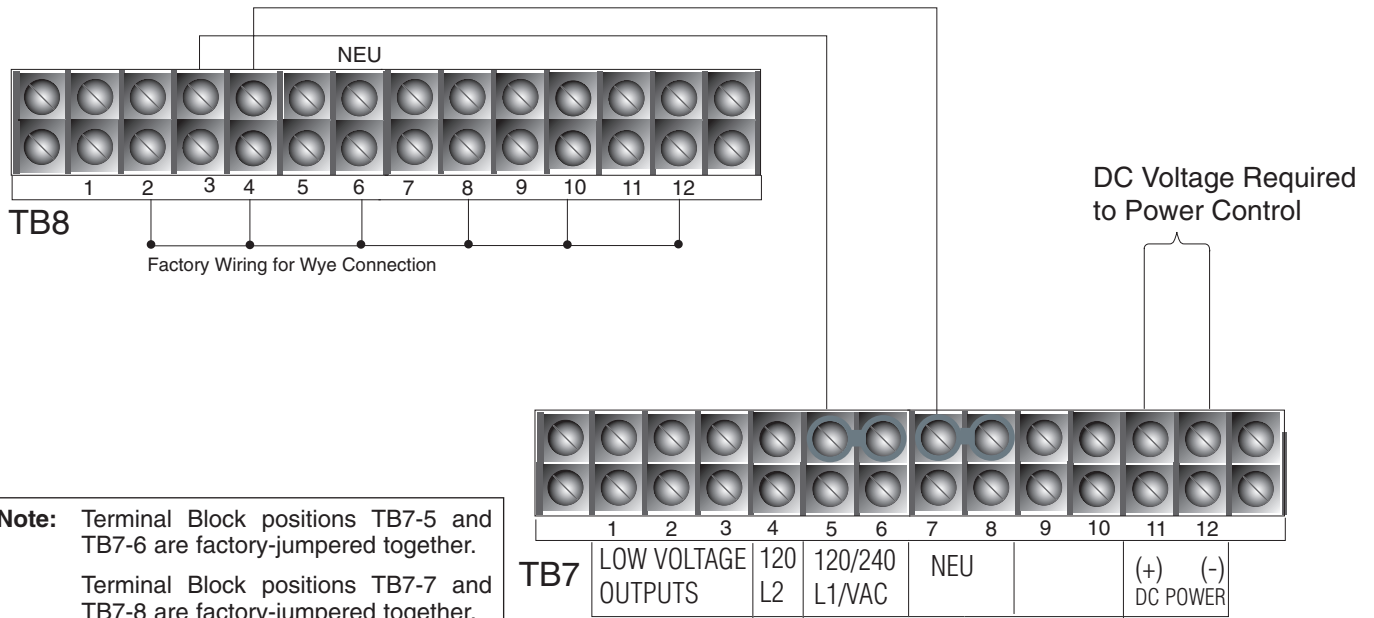

Figure 15.
Single-Phase Transformer Connection, B phase input for Voltage Sensing.
***Low Voltage Closing Accessory connects to TB7-1 and TB7-2.**

Voltage Sensing Connections			
Source			Load
V (1-2)	V(3-4)	V(5-6)	V1



Note: Terminal Block positions TB7-5 and TB7-6 are factory-jumpered together.
Terminal Block positions TB7-7 and TB7-8 are factory-jumpered together.

Figure 16. Default factory wiring connected to B-Phase voltage metering with B-Phase incoming supply.

Voltage Sensing Connections			
Source			Load
V (1-2)	V(3-4)	V(5-6)	V1

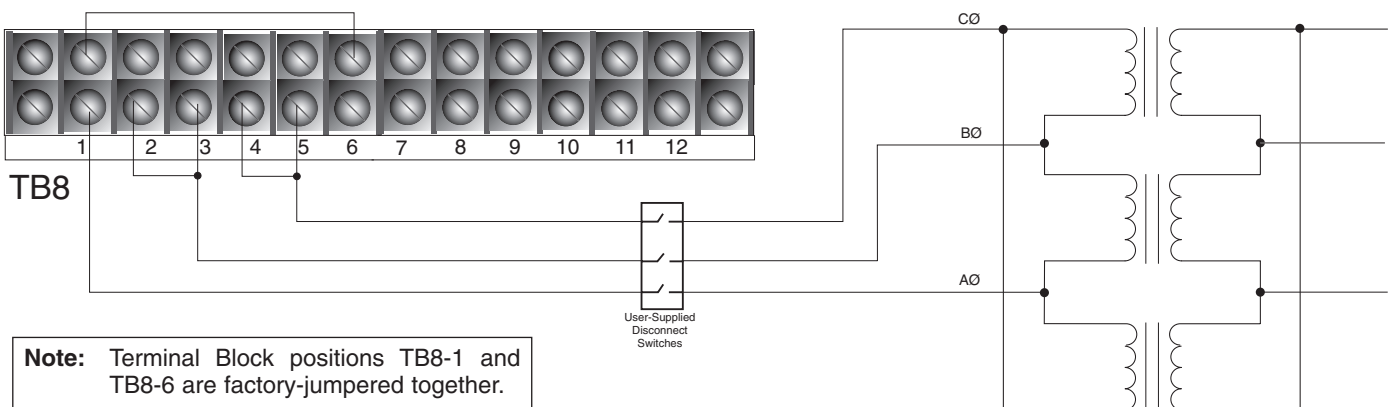

Note: Terminal Block positions TB8-1 and TB8-6 are factory-jumpered together.
Terminal Block positions TB8-2 and TB8-3 are factory-jumpered together.
Terminal Block positions TB8-4 and TB8-5 are factory-jumpered together.

Figure 17. Customer connections to TB8, 120 Vac Delta Connection.

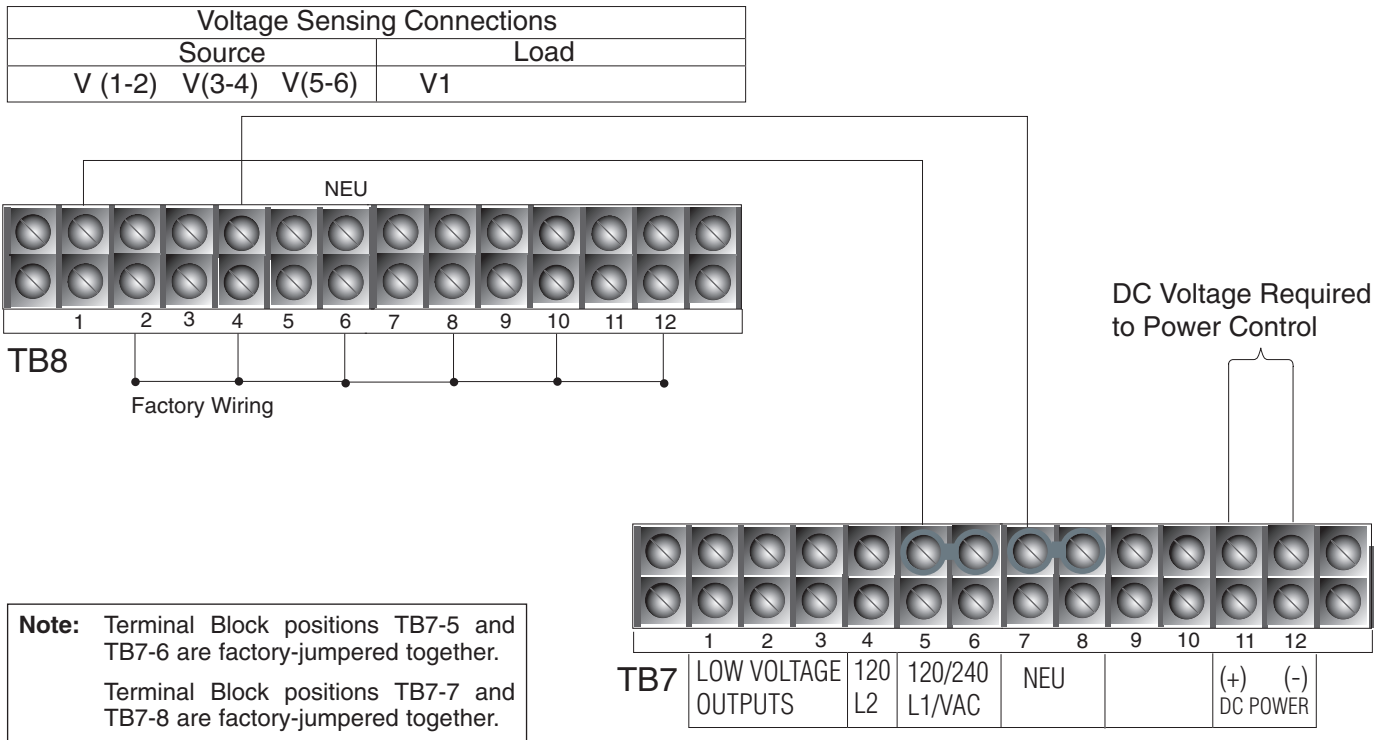

Figure 18. Modified wiring connected to A-Phase voltage metering with A-Phase incoming supply.

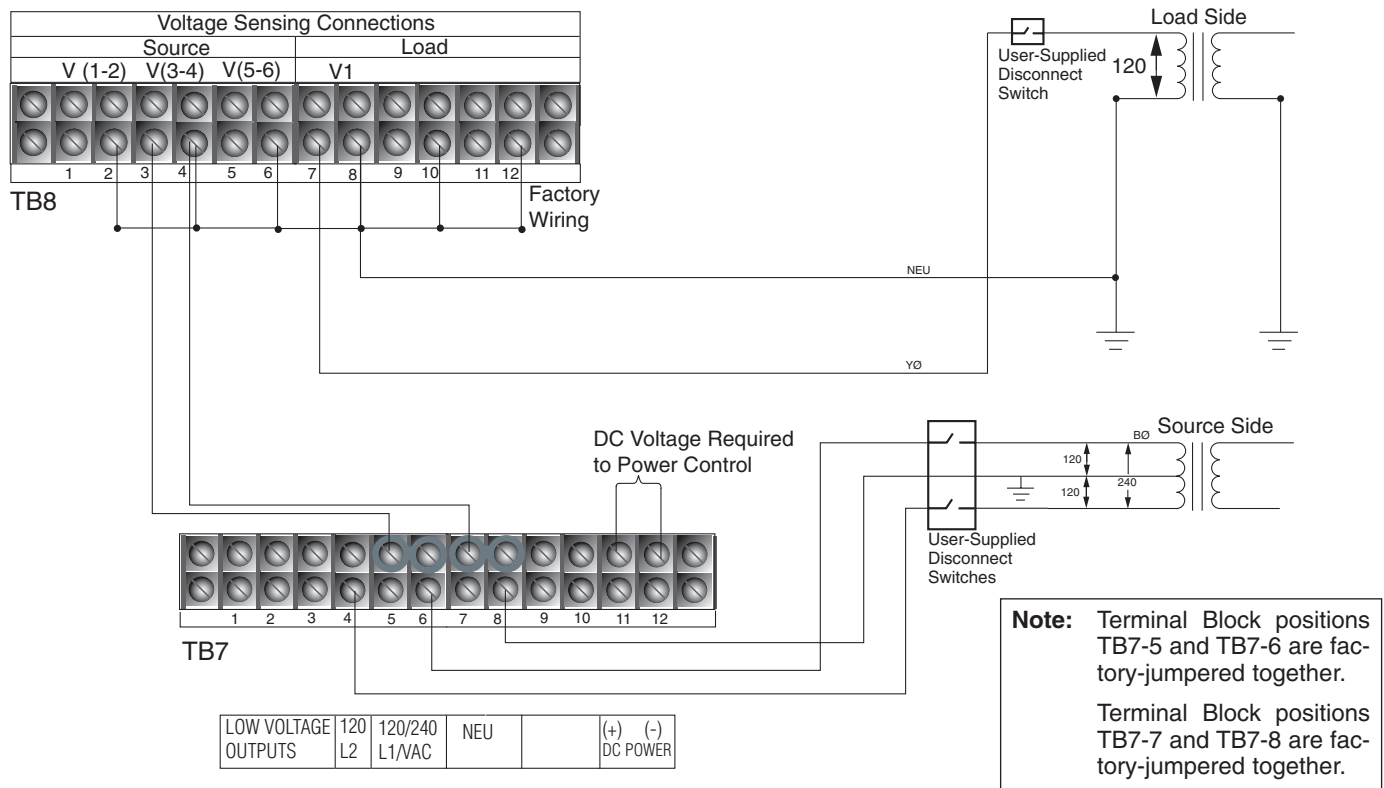

Figure 19. 240 Volt, 3-wire transformer connection for voltage and sensing on B-phase. *YØ for Sync Check Voltage.

Before Placing the Control and the Recloser into Service

CAUTION: Equipment misoperation. Do not connect this control to an energized recloser until all control settings have been properly programmed and verified. Refer to the programming information for this control. Failure to comply can result in control and recloser misoperation, equipment damage, and personal injury. G110.3

Prior to placing the control and recloser into service, the following installation procedures must be properly completed and verified:

1. Removable insert labels changed. (Not required – user-preference option.)

Note: Refer to **Using Removable Inserts** section in this manual for more information.

2. Control properly mounted for the installation.
3. Recloser installed according to all locally approved standards and practices.
4. Ac and dc disconnect switches installed.
5. Control wiring between control and recloser properly connected and supported.
6. Control and recloser properly grounded in accordance with guidelines in this manual and the applicable recloser manual.
7. Dc power and ac voltage sensing connected to the control.

Note: The control Power Save feature will turn off the backlit LCD display and all LEDs if no front panel keypad is pressed within ten minutes.

8. All control programming entered and verified by appropriate personnel.

Note: Refer to *Service Information S280-70-4 Kyle Form 6 Microprocessor-Based Recloser Control Programming Guide* for additional information.

9. Customer connections for remote and supervisory operation checked and completed in accordance with proper shielding and surge protection.

Standard Default Supervisory Input Control and Output Status Contacts

The standard Form 6 yard mount recloser control includes three control contact inputs and five status contact outputs. The standard default I/O terminal connections are identified in Figure 20. A discrete interface board accessory is available if additional I/O is required. The accessory includes eight control contact inputs and eight status outputs as identified in Figure 21.

All of the control inputs and status outputs are user-configurable via the Idea Workbench™. To avoid configuration time, the most common control inputs and status outputs are included as default values. Refer to Figures 20 and 21 and Tables 4, 5, and 6. Refer to *Service Information S280-70-4 Kyle Form 6 Microprocessor-Based Recloser Control Programming Guide* for additional information.

IMPORTANT

Shielding and Surge Protection of Supervisory Cables

All supervisory operation and control monitor leads must be protected within shielded cables. Refer to Figures 22 (12-48 Vdc whetting voltage option) or Figure 23 (48-125 Vdc, 120 Vac whetting voltage option).

CAUTION: Equipment damage; misoperation. External leads must be shielded and the shield must be grounded at both ends. Terminate each lead with a 320 Vac, 160 Joules metal oxide resistor (MOV), or equivalent, at the remote end. Attach MOVs between the leads and ground. Failure to properly shield and protect leads can result in equipment damage and/or unintentional operation. G117.3

TABLE 4
Operating Current Requirements for Standard and Optional Supervisory Inputs

Module Mfg. No.*	Input Voltage	Nominal Current	Minimum Operating Time
6A00160121 through 6A00160128	12 Vdc – 48 Vdc	5 mA	5 milliseconds
6A00160129 through 6A00160136	48 Vdc – 125 Vdc, 120 Vac	5 mA	5 milliseconds

*Refer to Figure 20 for location of Module Mfg. No.

TABLE 5
Ratings Table for Output Status Contacts CO1 through CO12 (TB1, TB3, and TB4) (Resistive Load – Pickup Time 8 ms, Dropout 5 ms)

Input Voltage	Contact Rating
120 Vac	8 A
12 Vdc	8 A
24 Vdc	8 A
48 Vdc	1 A
125 Vdc	0.4 A

TABLE 6
Ratings Table for Output Status Contact SS1 (Resistive Load – Pickup Time 2 ms, Dropout 15 ms) (TB1)

Input Voltage	Contact Rating
120 Vac	8 A
12 Vdc	8 A
24 Vdc	8 A
48 Vdc	8 A
125 Vdc	8 A

IMPORTANT

Shielding and Surge Protection of Supervisory Cables

All supervisory operation and control monitor leads must be protected within shielded cables. Refer to Figures 22 (12-48 Vdc whetting voltage option) or Figure 23 (48-125 Vdc, 120 Vac whetting voltage option).

CAUTION: Equipment damage; misoperation. External leads must be shielded and the shield must be grounded at both ends. Terminate each lead with a 320 Vac, 160 Joules metal oxide resistor (MOV), or equivalent, at the remote end. Attach MOVs between the leads and ground. Failure to properly shield and protect leads can result in equipment damage and/or unintentional operation.

G117.3

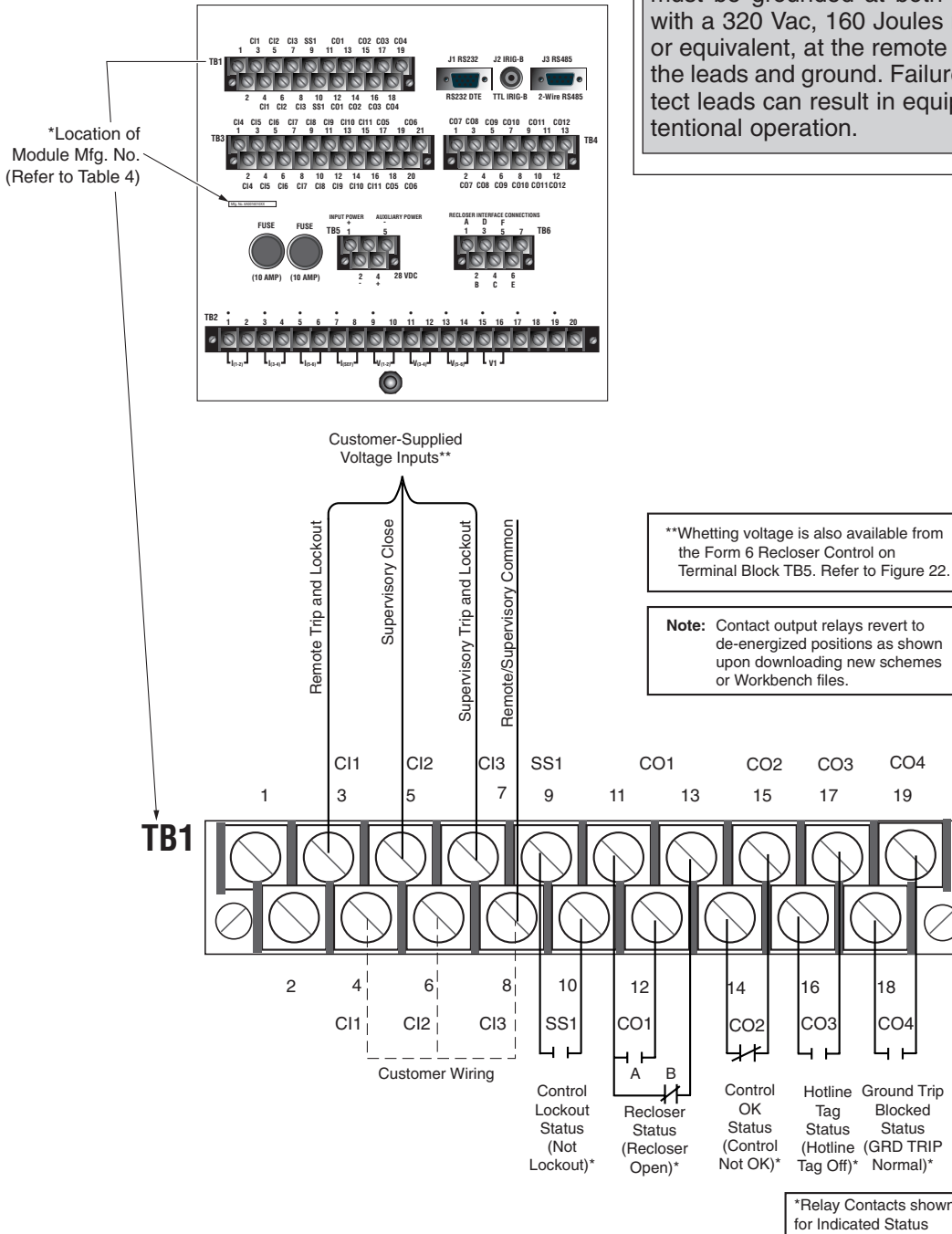

Figure 20. Form 6 recloser control Standard discrete interface board and default configurations. These default contact input/outputs are completely configurable via the Idea Workbench™.

IMPORTANT

Shielding and Surge Protection of Supervisory Cables

All supervisory operation and control monitor leads must be protected within shielded cables. Refer to Figures 22 (12-48 Vdc whetting voltage option) or Figure 23 (48-125 Vdc, 120 Vac whetting voltage option).

CAUTION: Equipment damage; misoperation. External leads must be shielded and the shield must be grounded at both ends. Terminate each lead with a 320 Vac, 160 Joules metal oxide resistor (MOV), or equivalent, at the remote end. Attach MOVs between the leads and ground. Failure to properly shield and protect leads can result in equipment damage and/or unintentional operation.

G117.3

**Whetting voltage is available from the Form 6 Recloser Control on Terminal Block TB5. Refer to Figure 22.

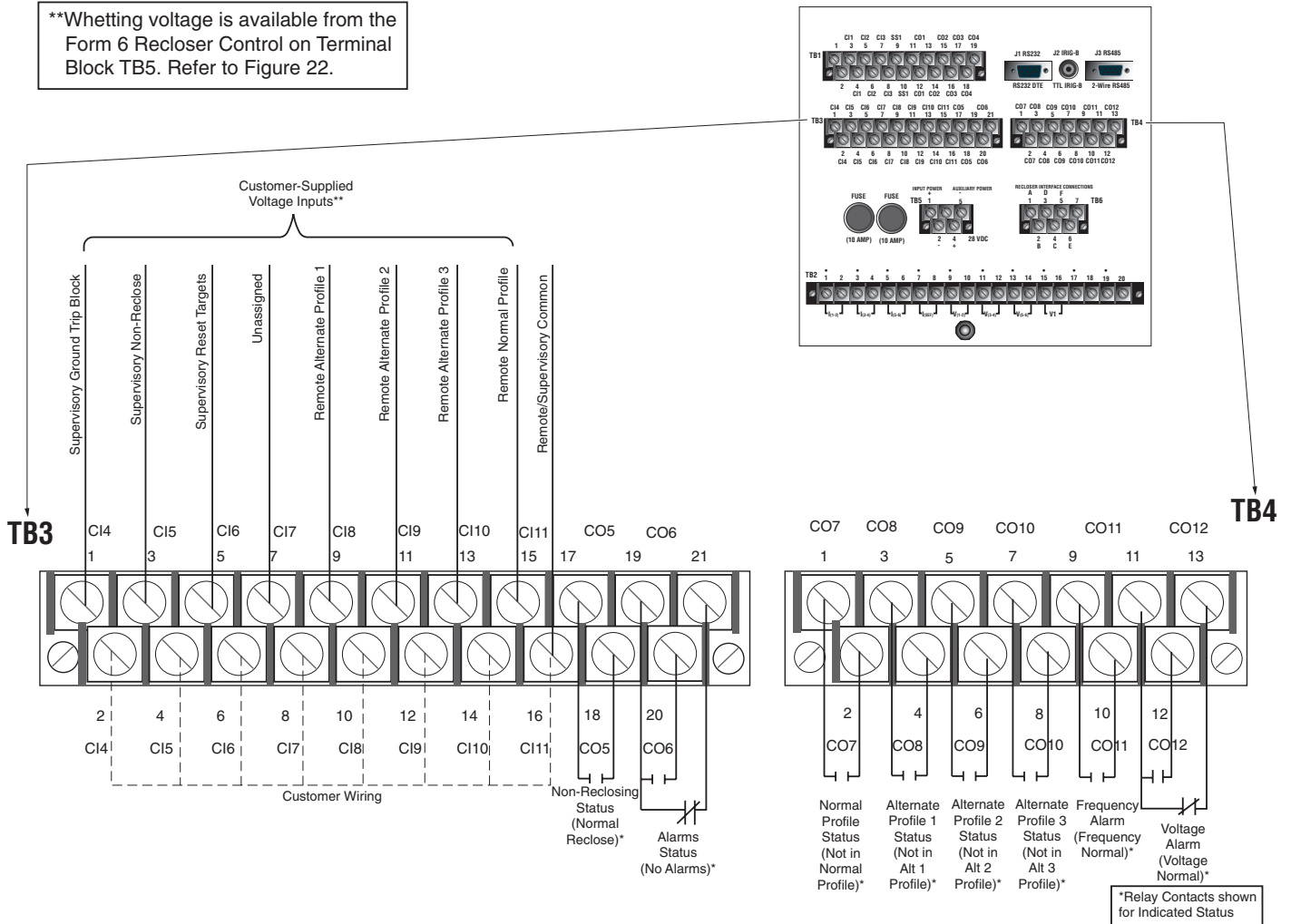

Figure 21. Form 6 recloser control discrete interface board accessory and default configurations. These default contact input/outputs are completely configurable via the Idea Workbench™.

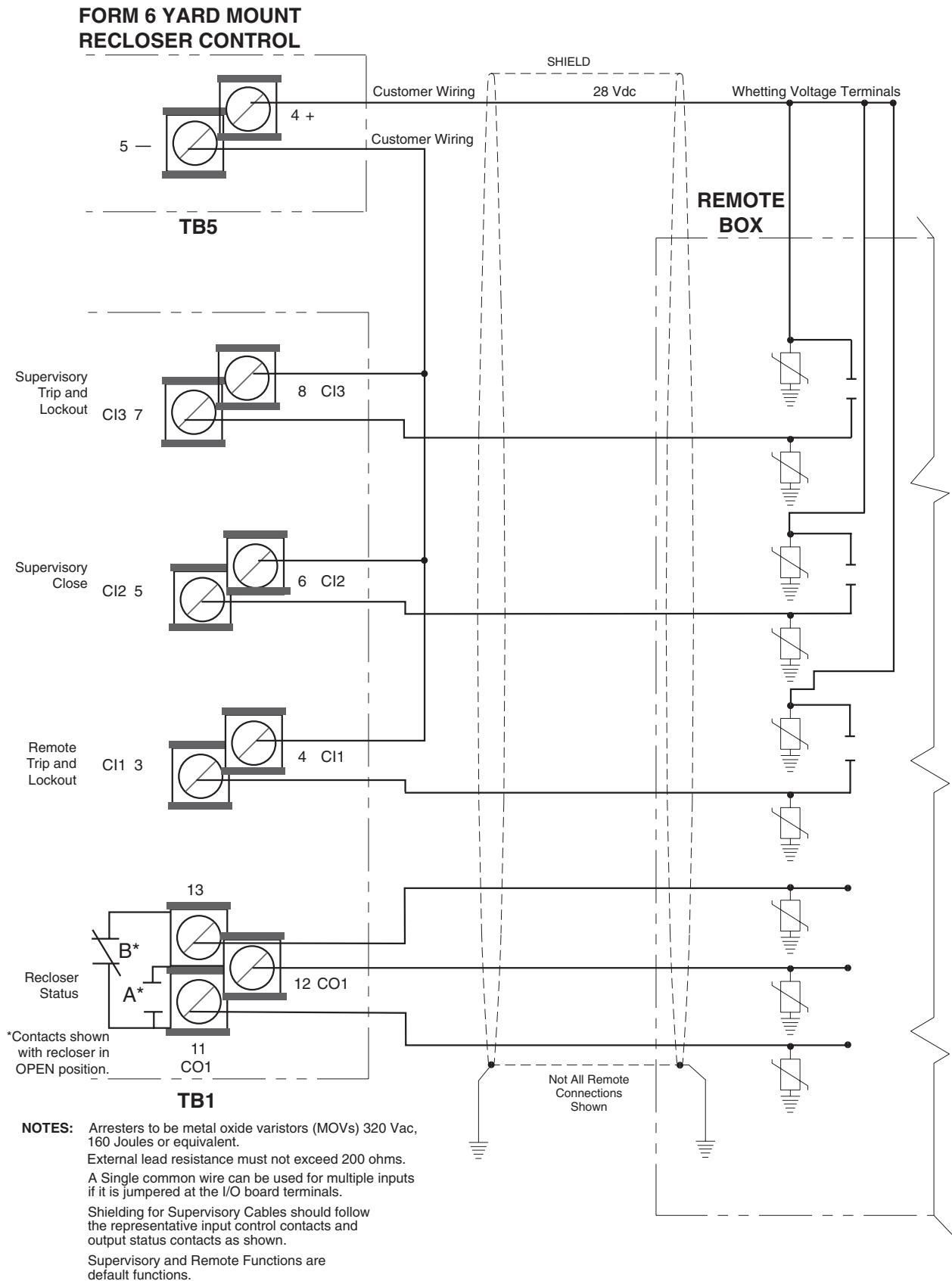

Figure 22. Shielding and Surge Protection for Supervisory and Remote Cables (12-48 Vdc option).

NOTES: Arresters to be metal oxide varistors (MOVs) 320 Vac, 160 Joules or equivalent.
 External lead resistance must not exceed 200 ohms.
 A Single common wire can be used for multiple inputs if it is jumpered at the I/O board terminals.
 Shielding for Supervisory Cables should follow the representative input control contacts and output status contacts as shown.
 Supervisory and Remote Functions are default functions.

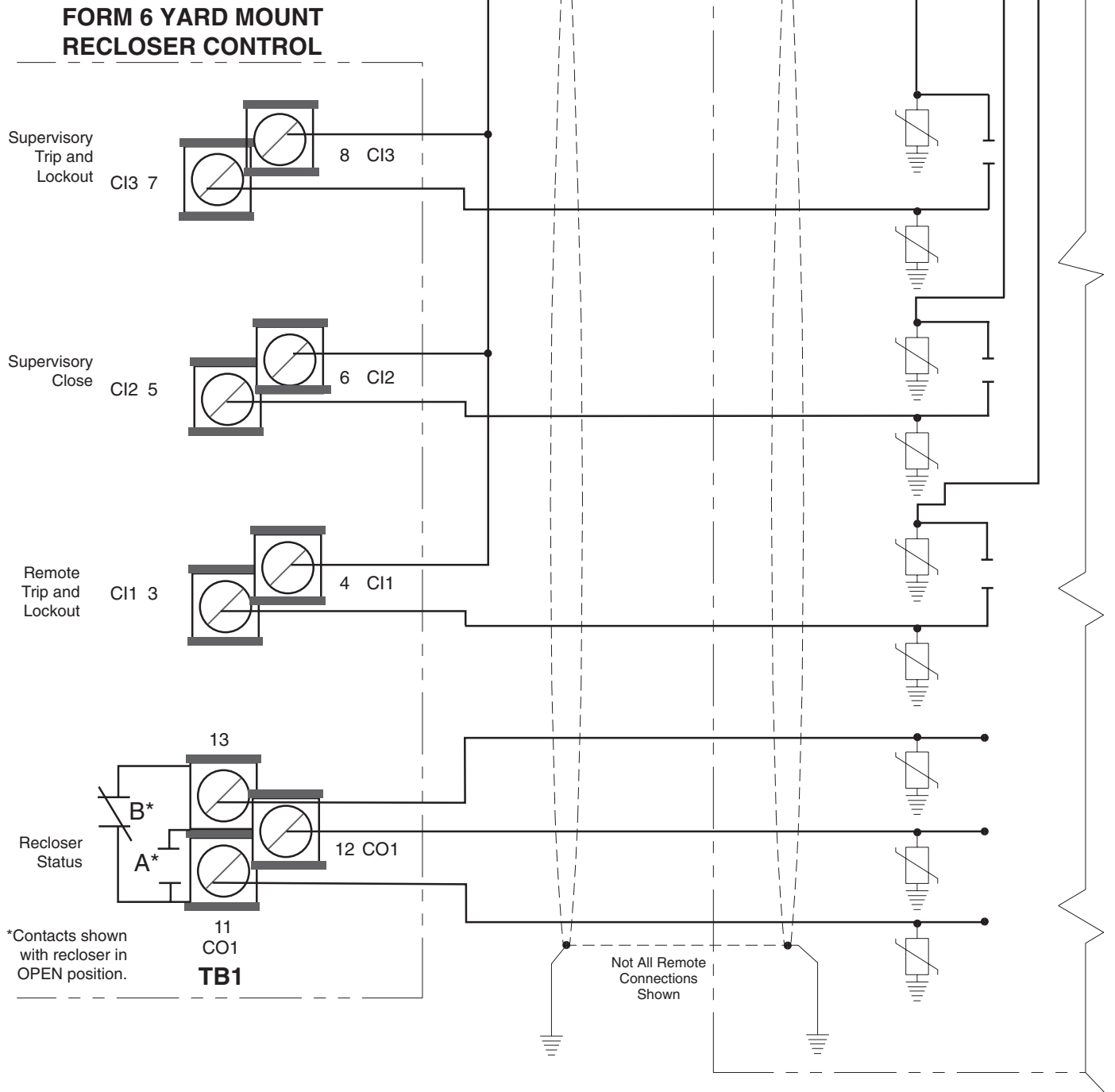

Figure 23. Shielding and Surge Protection for Supervisory and Remote Cables (48-125 Vdc, 120 Vac option).

Rear Panel Communication Port Pin Assignments

Tables 7 and 8 indicate the pin assignments for the rear panel RS-232 and RS-485 communication ports (Figure 24). Refer to Figures 25 and 26 for pin identification. Refer to **Protocols** for additional information.

TABLE 7
Rear Panel RS-232 Communication Port Pin Assignments

Pin Number	Signal Name
1 DCD	Carrier Detect
2 RXD	Receive Data
3 TXD	Transmit Data
4 DTR	Data Terminal Ready (Not Connected)
5 GND	Signal Ground
6 DSR	Data Set Ready (Not Connected)
7 RTS	Request to Send
8 CTS	Clear to Send
9 N.C.	Not Used
10 (Shroud)	Chassis Ground

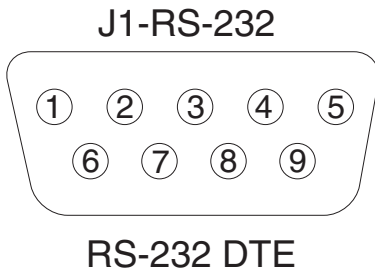

Figure 25.
Rear Panel RS-232 Communication Port Pin Identification.

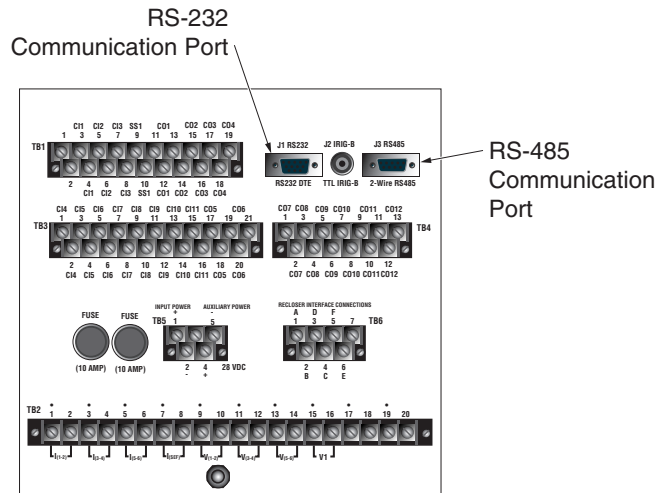

Figure 24.
Form 6 recloser control rear panel RS-232 and RS-485 communication ports.

TABLE 8
Rear Panel RS-485 Communication Port Pin Assignments

Pin Number	Signal Name
1 SGND	RS-485 Signal Ground (Same as 3)
2 GND	Chassis Ground
3 SGND	RS-485 Signal Ground (Same as 1)
4 A	RS-485 "A" Signal (+) (Same as 8)
5 B	RS-485 "B" Signal (-) (Same as 9)
6 GND	Chassis Ground
7 GND	Chassis Ground
8 A	RS-485 "A" Signal (+) (Same as 4)
9 B	RS-485 "B" Signal (-) (Same as 5)

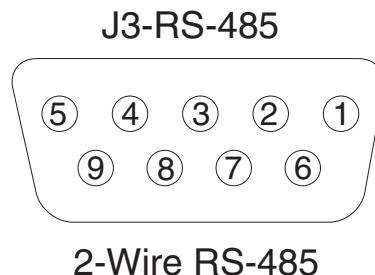

Figure 26.
Rear Panel RS-485 Communication Port Pin Identification.

Using Removable Inserts

CAUTION: Control damage. De-energize both ac and dc power prior to removing or installing any internal connections or circuit boards in the control. Failure to comply can result in damage to the control. T241.1

CAUTION: Equipment damage. Always wear a grounding wrist strap to control static electricity before handling circuit boards. Failure to use this strap may result in circuit board damage. T253.1

The removable insert labels on the operating panel (OPTION 1, OPTION 2, and OPTION 3) or LED Status Indicators on the programming panel (INDICATOR 1, INDICATOR 2, AND INDICATOR 3), can be changed, if desired.

1. De-energize both ac and dc power.
2. Use a flathead screwdriver to unscrew the six front panel screws.
 - Note:** Set the screws aside for later use.
3. Pull the right side of the front panel out towards the left (Figure 27).
 - Note:** Various connecting wires will keep the panel attached to the control.
 - Note:** It is not necessary to disconnect any wires.

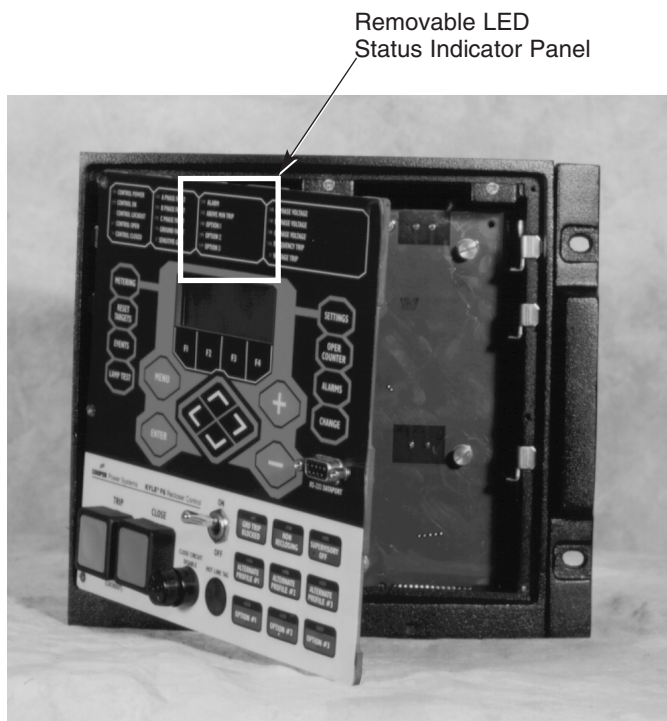

Figure 27. Open front panel. Labels (INDICATOR 1, INDICATOR 2, AND INDICATOR 3) are easily removed from and inserted into the top of the programming panel LED status indicator section. 010063KM

4. Use tweezers to gently pull out the removable insert.
 - Note:** The insert will slide out of the right side of the operating panel (Figure 28).
 - Note:** The insert will slide out of the top of the programming panel indicator section (Figure 27).
5. Change the existing label or slide in a new label with the name of the configured option.

An electronic label template is included on the ProView™ application software CD and can be accessed through the following default address:

C: / Program Files / Cooper / Proview40 / Form 6 / Form 6 Inserts.doc

IMPORTANT: Laminate the removable inserts prior to installing. This will seal the ink/toner and avoid damage to the front panel.

6. Gently push the removable insert from right to left into the right side of the operating panel (Figure 28) or down into the programming panel LED indicator section (Figure 27).
7. Place the front cover panel back onto the control. Use a flathead screwdriver to screw the screws back into the control and tighten all hardware completely.

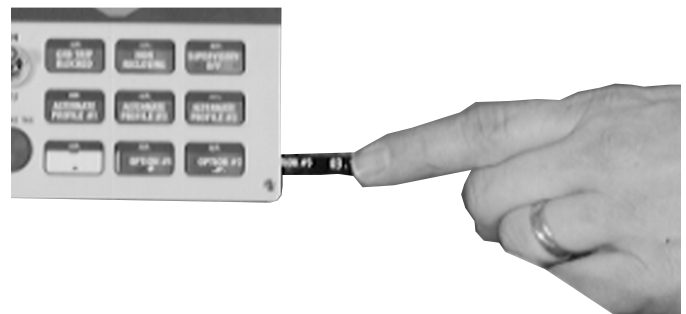

Figure 28. Labels (OPTION 1, OPTION 2, and OPTION 3) are easily removed from and inserted into the operating panel. 000008KM

ACCESSORIES

These accessories are available. Contact your Cooper Power Systems representative for additional information.

Control Cable

The control cable is fabricated with connectors which mate with the female receptacle of the recloser on one end, and the male receptacle of the control or junction box on the other end. Refer to Table 3 for available control cable lengths.

Front Panel with Expanded LEDs

An ordering option for the front panel of the Form 6 yard mount recloser control includes the availability of additional configurable LEDs (Figure 29). The user is able to configure five additional LEDs for numerous status, alarms, or events using the Idea Workbench™ feature in the ProView™ interface software.

Discrete Interface Board (DIF) Option Accessory

If additional I/O is required, a Discrete Interface Board Option accessory is available. The accessory includes eight control contact inputs and eight status outputs as identified in Figure 21. Refer to **Customer Connections for Dc Power and Ac Voltage Sensing** for additional information.

RS-232 Cable

A nine-pin RS-232 Cable is available to connect from the personal computer to the data port on the front panel of the Form 6 yard mount recloser control. The cable is 6 feet in length. The front panel RS-232 port is wired as a DCE port for direct connection to the personal computer.

120 Vac GFI Duplex Outlet

The GFI Duplex Outlet is available for controls powered by 120 Vac three-wire supply power. This convenience outlet is rated for 15 Amperes and is accessible through the front door in the control cabinet. The 120 Vac GFI Duplex Outlet is used for many applications such as power for the MET Tester, auxiliary measurement equipment, and supplemental lighting.

Cable Locking Sleeves

To prevent detachment of the control cable from the control cabinet by unauthorized personnel, a cable-locking sleeve is available to enclose the cable plug. The plug is passed through the sleeve and the sleeve is then fastened from inside the control cabinet. There is no access to the cable receptacle without opening the locked cabinet door and detaching the sleeve.

Incoming Power Receptacles

The Incoming Power Receptacle allows the user to conveniently plug the power cable into the control, eliminating the need for hardwiring to the control. Various options are available based upon the input power voltage, and phase sensing requirements. Table 9 includes the available input receptacles for the Form 6 recloser control.

Stainless Steel Cabinet

A cabinet constructed from AISI 304 stainless steel is available as an accessory.

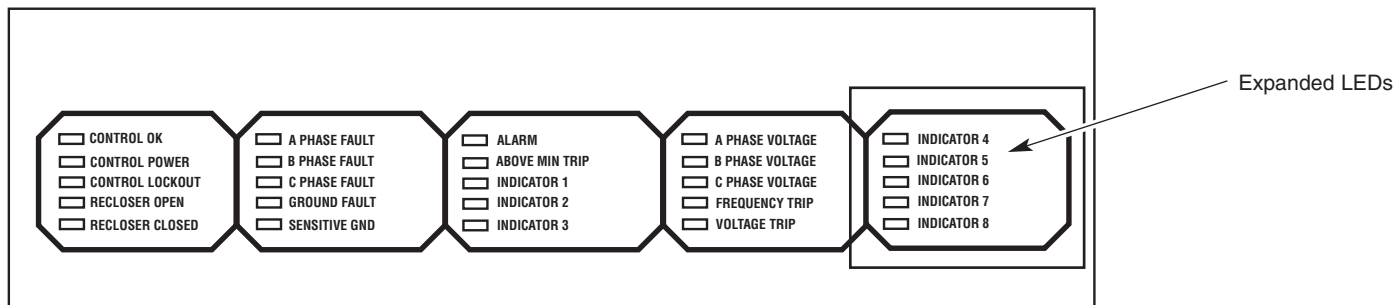

Figure 29. Expanded status indicator LEDs.

Fiber Optic Interface Accessory

The fiber optic interface accessory, (Figure 30), Catalog Number KME6-1875-2, provides a fiber-optic serial interface for two-way, real-time, serial communications with a remote terminal unit (RTU), telephone modem, or personal computer.

IMPORTANT: The KME6-1875-2 fiber optic accessory kit can not be combined, installed, or used with the KME6-1801-1 auxiliary switch accessory kit.

Low Voltage Closing

The Low Voltage Closing Accessory utilizes 120 or 240 Vac for closing power (Figures 31, 32, 33, and 34). Multiple low voltage closing accessories are available for reclosers equipped with low voltage closing. The low voltage closing accessories available for the Form 6 recloser control include the appropriate receptacles and wiring based upon the input supply voltage. Table 9 lists the available low voltage closing input/output receptacles for the Form 6 recloser control.

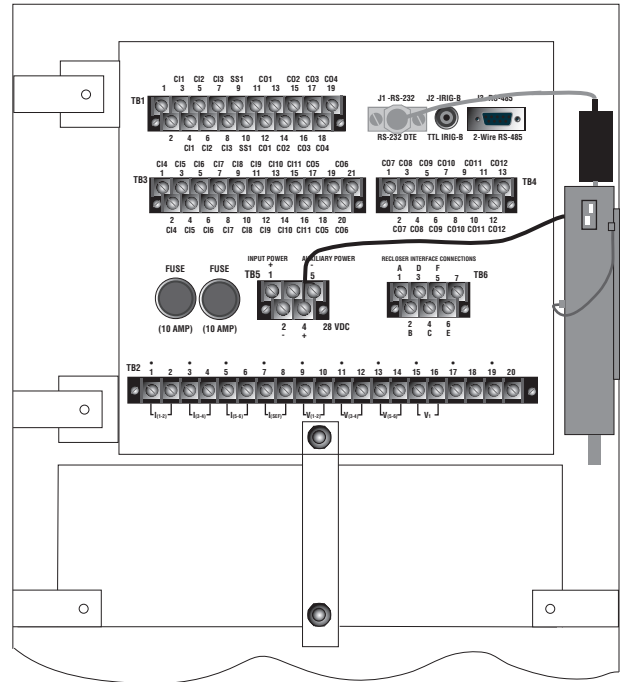

Figure 30.
KME6-1875-2 Form 6 yard mount control fiber optic interface accessory.

TABLE 9
Low Voltage Closing Receptacles

Description	Catalog Number
120 Vac low-voltage closing 2-pin input and 2-pin output receptacles	KME6-1838-A
120 Vac low-voltage closing with 3-pin input and 2-pin output receptacles	KME6-1838-B
120 Vac low-voltage closing with inlet hole and 2-pin output receptacle	KME6-1838-C
240 Vac low-voltage closing with 2-pin input and 2-pin output receptacle	KME6-1838-D
240 Vac low-voltage closing with 3-pin input and 2-pin output receptacle	KME6-1838-E
240 Vac low voltage closing, for 2-wire with inlet hole and 2-pin output receptacle	KME6-1838-F
240 Vac low-voltage closing, for 3-wire with inlet hole and 2-pin output receptacle	KME6-1838-G
120 Vac or 240 Vac input receptacle, 2-pin	KME6-1838-H
120 Vac input receptacle, 3-pin	KME6-1838-J
240 Vac input receptacle, 3-pin	KME6-1838-K

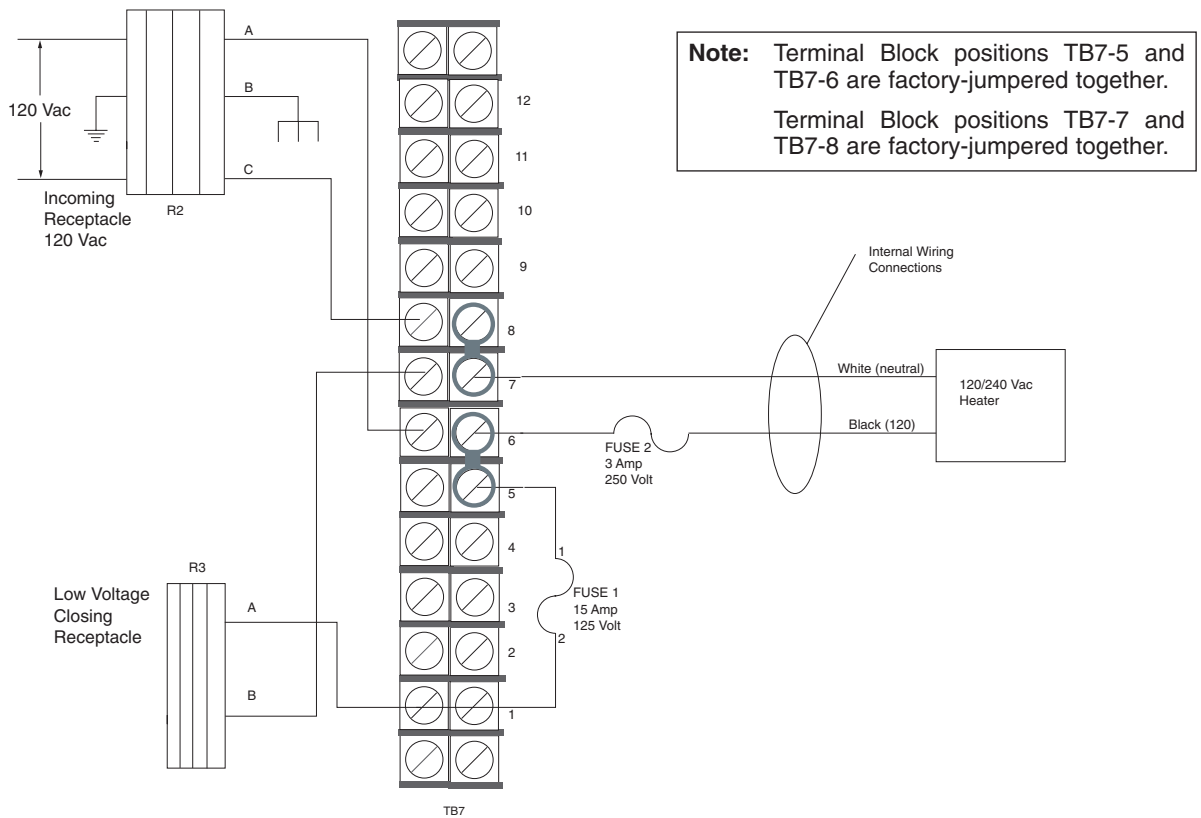

Figure 31.
Single-phase 120 Vac low voltage closing accessory with incoming ac receptacle and low voltage closing receptacle.

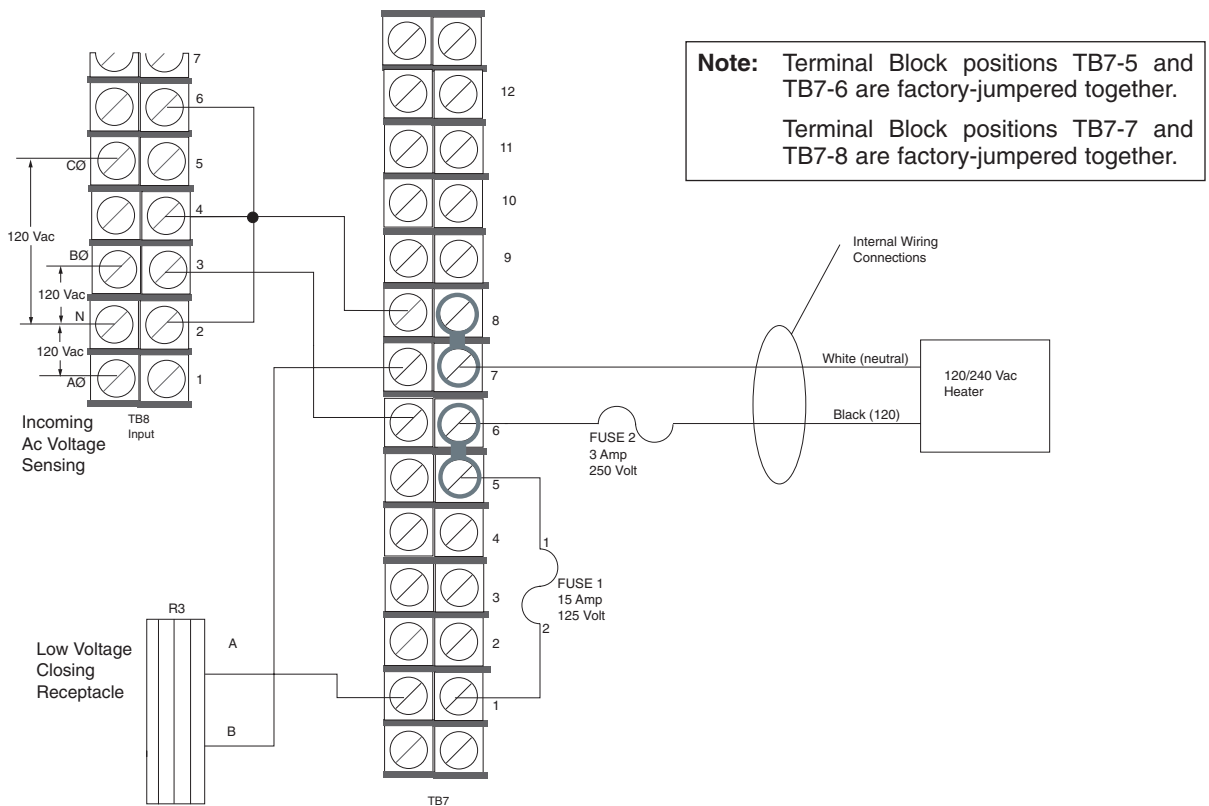

Figure 32.
Single-phase 120 Vac low voltage closing accessory with incoming ac terminal block and low voltage closing receptacle.

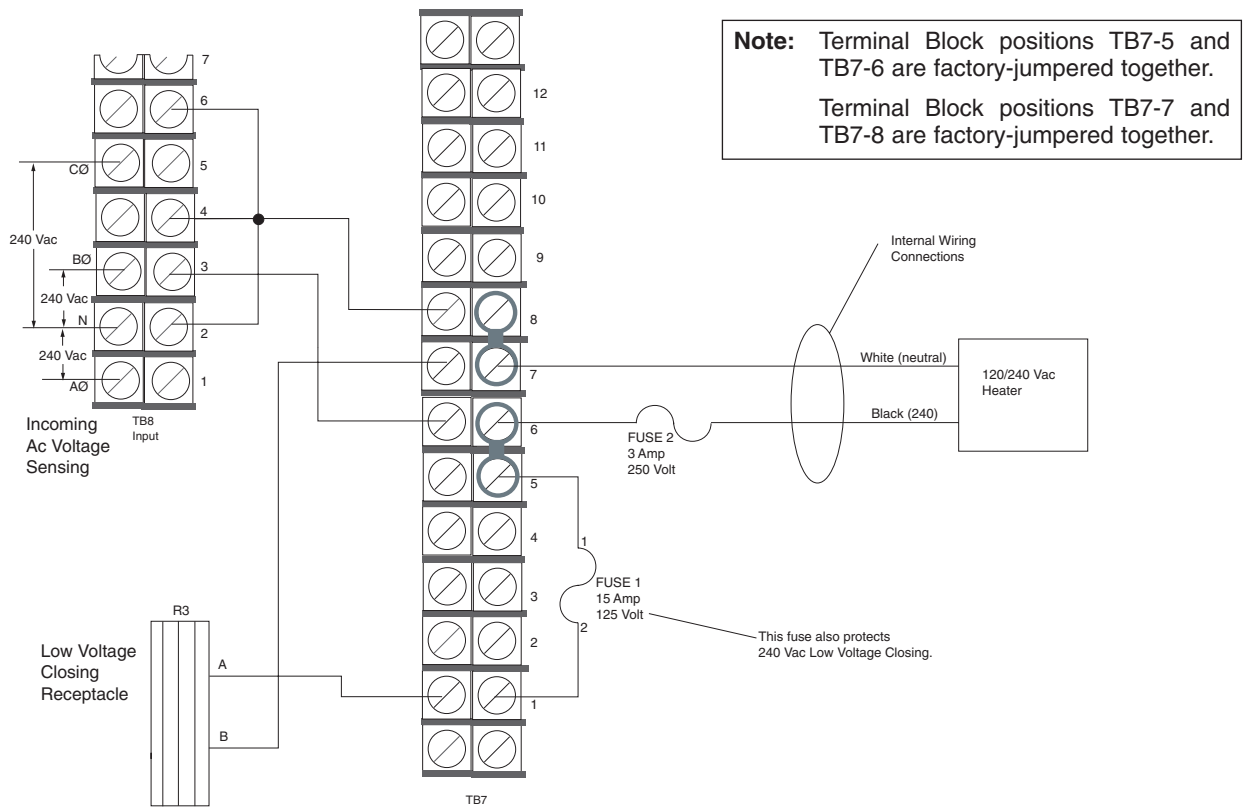

Figure 33.
240 Vac low voltage closing accessory with incoming ac terminal block and low voltage closing receptacle.

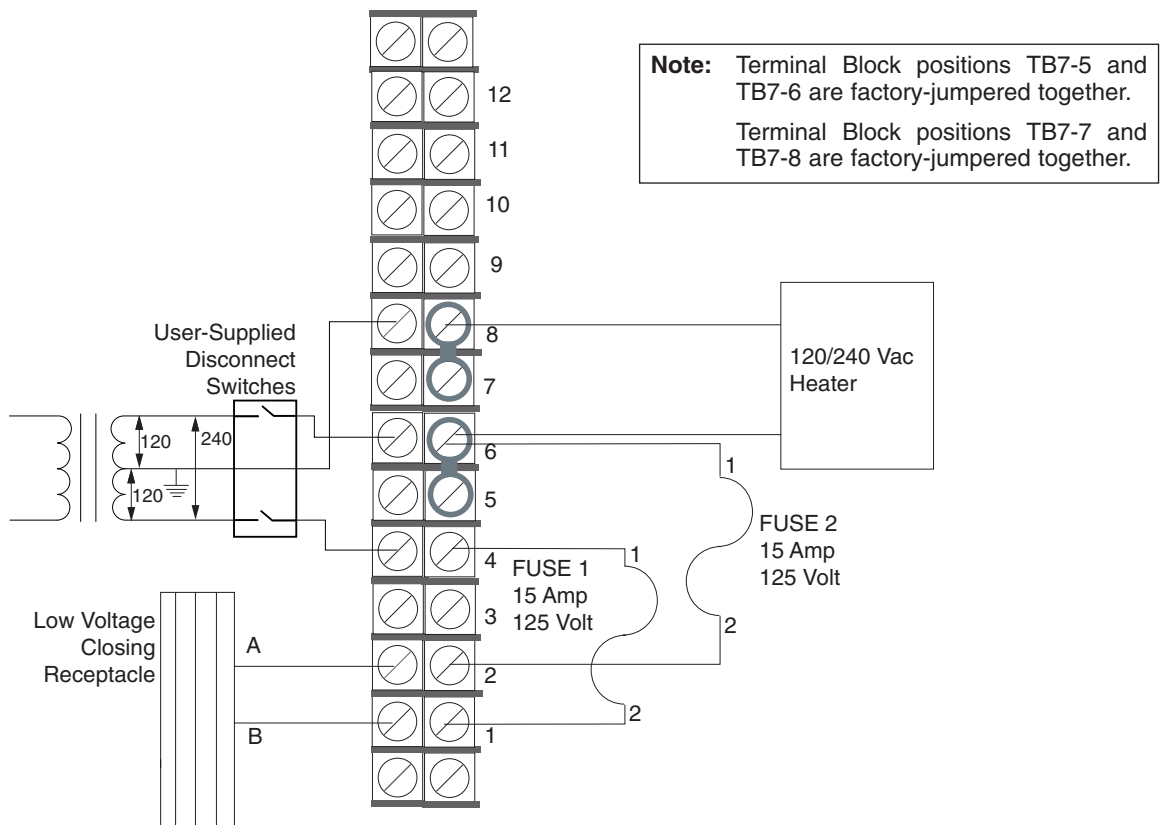

Figure 34.
240 Volt, 3-wire transformer connection with 240 ac low voltage closing accessory.

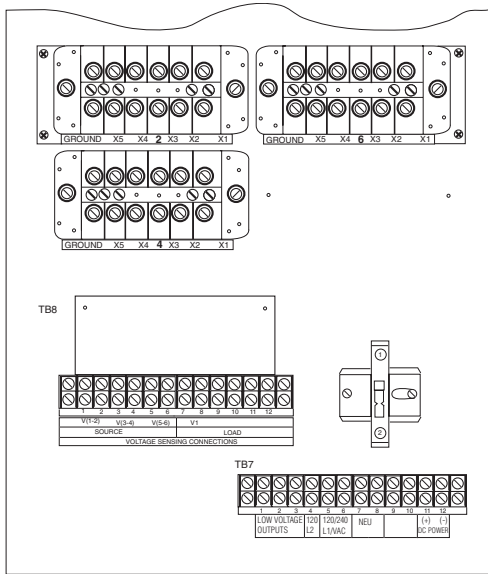

Figure 35.
Form 6 recloser control BCT terminal block accessory – Load side.

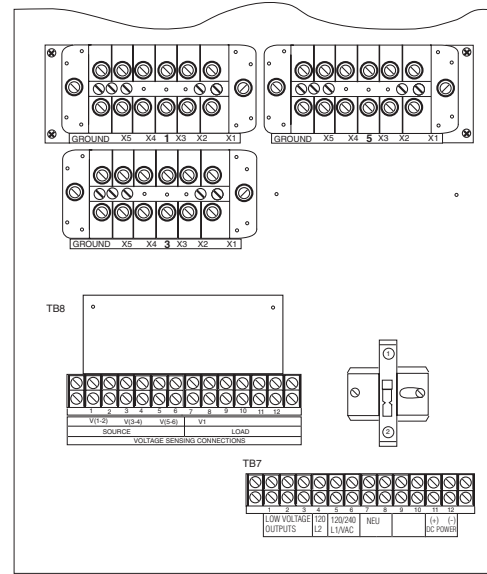

Figure 36.
Form 6 recloser control BCT terminal block accessory – Source side.

BCT Terminal Blocks Accessory

The BCT Terminal Blocks (Figures 35, 36, and 37) attach to the back of the control and provide a connection point for external 600:5 or 1200:5 multi-ratio bushing current transformers. BCT Terminal Blocks are available for the load, source, or both load and source BCTs. Refer to Table 10.

Auxiliary Terminal Block Accessory

An auxiliary terminal block and receptacle is available for three-stage auxiliary switch wiring. Refer to Table 10.

TABLE 10
Terminal Blocks

Description	Catalog Number
BCT shorting-type terminal block for (Load) bushings 2, 4, 6	KME6-1821-A
BCT shorting-type terminal block for (Source) bushings 1, 3, 5	KME6-1821-B
BCT shorting-type terminal block for both LOAD and SOURCE bushings	KME6-1821-C
Terminal block and receptacle for wiring of three-stage auxiliary switch, KA542R3	KME6-1801-1

Note: BCT Terminal Blocks 1 and 2 mount over top of BCT Terminal Blocks 3 and 4.

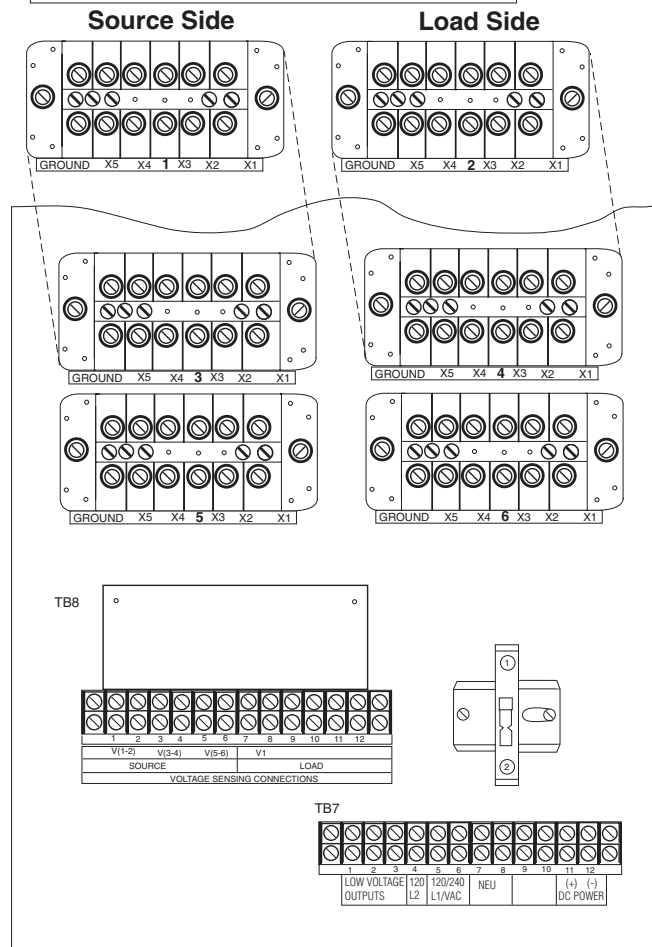

Figure 37.
Form 6 recloser control BCT terminal block accessory – Source and Load side.

TESTING

CAUTION: Equipment misoperation. Do not connect this control to an energized recloser until all control settings have been properly programmed and verified. Refer to the programming information for this control. Failure to comply can result in control and recloser misoperation, equipment damage, and personal injury.

G110.3

IMPORTANT: The Form 6 recloser control can be taken out of service for testing and placed back into service without de-energizing its recloser and interrupting the system. However, during the time the control is out of service, the recloser is inoperative.

Testing an Installed Control

The following tests to determine initial operation of the Form 6 recloser control can be performed while connected to an operating recloser.

Note: These are the only tests performed on an installed, operating control.

1. Verify operating status of all indicator lights by pressing the LAMP TEST key on the programming panel (Figure 38).
2. Check the operational values for currents, voltages, and other metering information.

Note: Scroll through the LCD display messages by pressing the \blacktriangle and \blacktriangledown cursor movement arrows underneath the LCD display on the programming panel (Figure 38).

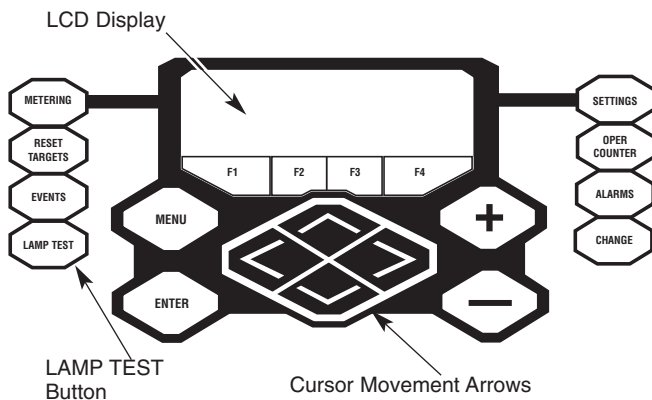

Figure 38. Lamp Test button, LCD display, and cursor movement arrows.

3. Check that the LED for Control OK is illuminated on the control operator panel (Figure 39). This indicates the presence of dc power.

Note: The control includes a Power Save feature that will turn off the backlit LCD display and all LEDs if no front panel keypad is pressed within ten minutes. Pressing any key will reactivate the display and LEDs.

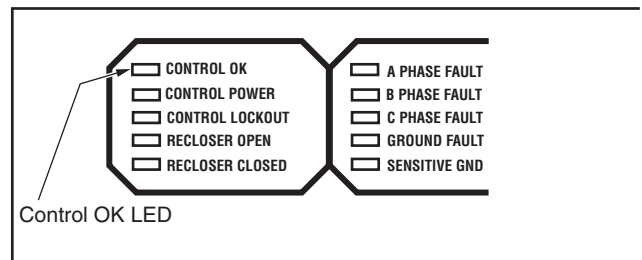

Figure 39. Control OK LED.

All other tests described in this **TESTING** section require the Form 6 recloser control to be removed from service, connected to a bypassed recloser, or tested at a location where the proper testing equipment is available. Refer to **Remove the Control from Service** for the proper procedure to remove the control from service.

Remove the Control from Service

IMPORTANT: Disconnect switches for ac sensing and power connections are necessary to isolate the Form 6 control for testing and servicing.

1. Enable GRD TRIP BLOCKED to allow for ground trip to be disabled when re-energized.
 - A. Press the CHANGE button on the Operator Panel to enter the CHANGE mode.
 - B. Depress the GRD TRIP BLOCKED button within ten seconds after entering the CHANGE mode.

Note: If the GRD TRIP BLOCK button is not depressed within ten seconds, the function is not activated.
2. Remove dc power from the control using a separate disconnect switch.
3. Remove control ac sensing voltage from the control using a separate disconnect switch.

WARNING: Hazardous voltage. If the recloser is energized while the control cable is disconnected, the CT secondaries can generate high voltages. Contact with high voltage can cause severe personal injury or death.

T204.2

4. Disconnect control cable from the control.
5. Remove any control input and status output wiring from TB1, TB3, and TB4 (Figure 8).
6. Disconnect any serial communications ports and IRIG-B timing connections (Figure 8).
7. Disconnect the ground from the control.

Testing with Type MET Tester

The Kyle® Type MET electronic recloser control tester (Figure 40) is used for testing the following functions of the Form 6 recloser control:

- Overcurrent Timing
- Reclose Time
- Operating Sequence
- Reset Time
- Minimum Trip Current
- High Current Trip and Lockout



Figure 40.
Kyle® Type MET electronic recloser control tester.

010028KM

The MET Tester is completely self-contained, capable of performing all required checks and tests from a simple verification of operation to a complete verification of all operating parameters.

Refer to *Service Information S280-76-1 Type MET Electronic Recloser Control Tester Operating Instructions* for proper setup and use of the MET Tester.

Closing the Recloser During Testing

Electrical Closing – Solenoid-Operated Reclosers

Line voltage is required for automatic recloser operation during testing of reclosers equipped with a closing solenoid (except for reclosers equipped with the low voltage closing accessory).

WARNING: Hazardous voltage. Interconnect source leads X and Y and ground solidly to the recloser tank (Figure 43). Do not connect lead Z to any other phase or mechanical ground. Dangerous voltages to ground exist on the phase connected to lead Z. Solidly ground all equipment. Failure to comply can result in severe personal injury and/or equipment damage. T224.1

For on-line testing, bypass the recloser, open the load-side disconnects and keep the source-side disconnects closed. This will remove the recloser from service, but will keep line voltage supplied to the closing solenoid (Figure 41).

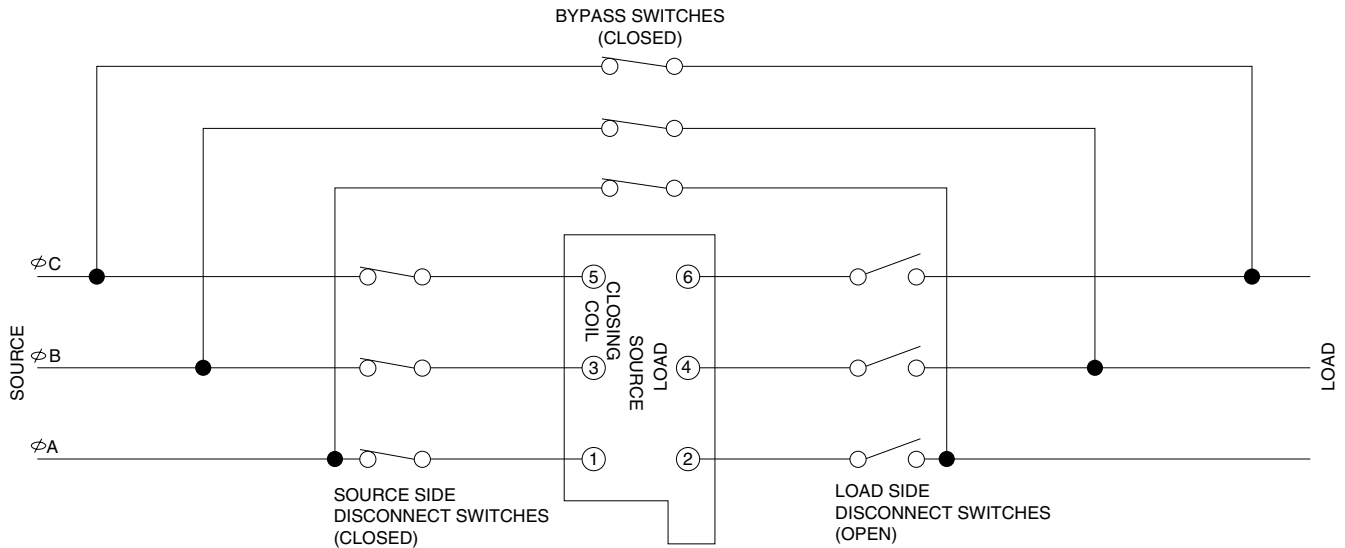

Figure 41. Closing source-side switches of a bypassed “on-line” recloser provides closing solenoid power for automatic operation during testing.

WARNING: Hazardous voltage. The switchgear and high voltage transformer must be in a test cage or similar protective device to prevent accidental contact with the high voltage parts. Solidly ground all equipment. Failure to comply can result in death, severe personal injury, and equipment damage. T221.3

For shop testing, the closing solenoid voltage is supplied by back-feeding a transformer with a low-side rating equal to the voltage rating of an available power source, and a high-side rating equal to the voltage rating of the recloser (Figure 41). A 75 kVA transformer of the proper voltage rating with an impedance drop of approximately 3% is satisfactory. The ac source must have a comparable impedance drop.

A test circuit for these solenoid-closed reclosers is shown in Figure 43. The following equipment is required for the recommended shop testing setup:

Note: Solenoid-closed reclosers equipped with a 120- or 240-Vac low-voltage closing coil accessory can be tested as shown in Figure 44.

- Variable Autotransformer T1, 230 Volts, 20 Amps.
- Low-Voltage transformer T2 to simulate fault conditions.

Ratio and size will depend upon the maximum current to be used. The recloser presents a low impedance to the transformer, so secondary voltage must be only high enough to force the required current through the secondary of the transformer and the recloser.

Note: An alternative method of providing the necessary current through the transformer is shown in Figure 42.

- High-Voltage T3 to operate the closing solenoid.

The closing coil requirement is approximately 200 kVA during the two-to-three cycle closing operation. The solenoid coil operating voltage must be maintained at the recloser bushings during the cycle interval the closing coil is energized. This procedure is not used on reclosers equipped with the low-voltage closing accessory.

- Ammeter with a rating based on the level of test current.
- Current-actuated timer.

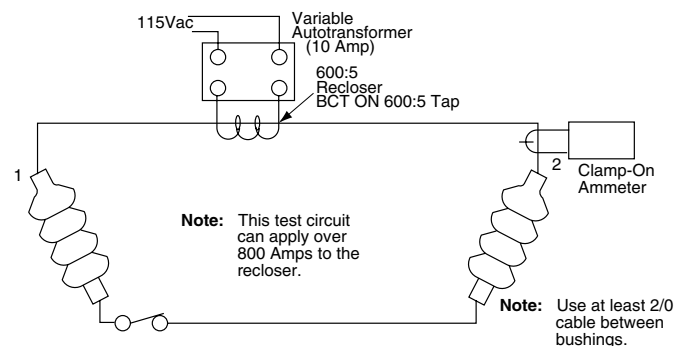

Figure 42. Alternate method of producing variable line current (substitute for T2 and W-X circuit in Figures 43 and 44).

Electrical Closing – Motor-Operated Low Voltage Closing Solenoid / Auxiliary-Powered NOVA Reclosers

WARNING: Hazardous voltage. Solidly ground all equipment. Failure to comply can result in death, severe personal injury, and equipment damage.

T223.2

High-voltage is not required for reclosers utilizing a motor-operated closing mechanism, low voltage closing, or auxiliary-powered NOVA recloser. For information on energizing the recloser, refer to the appropriate recloser installation manual. Low voltage supply can use either 120 or 240 Vac for input power. Check the name plate on the recloser to verify the correct closing power requirements.

Figure 44 shows a test circuit for motor-operated, low-voltage solenoid-closing, and auxiliary-powered NOVA reclosers. Since these reclosers require only a low voltage source for closing, high-voltage transformer T3 and its protective cage is eliminated. All other equipment is the same as the test equipment shown in Figure 43.

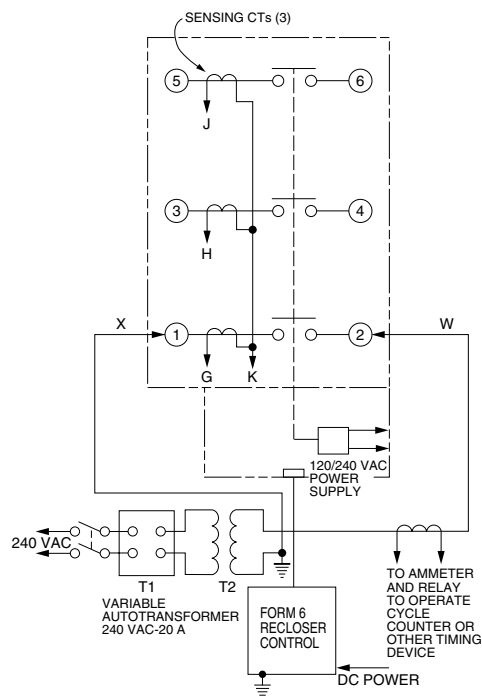
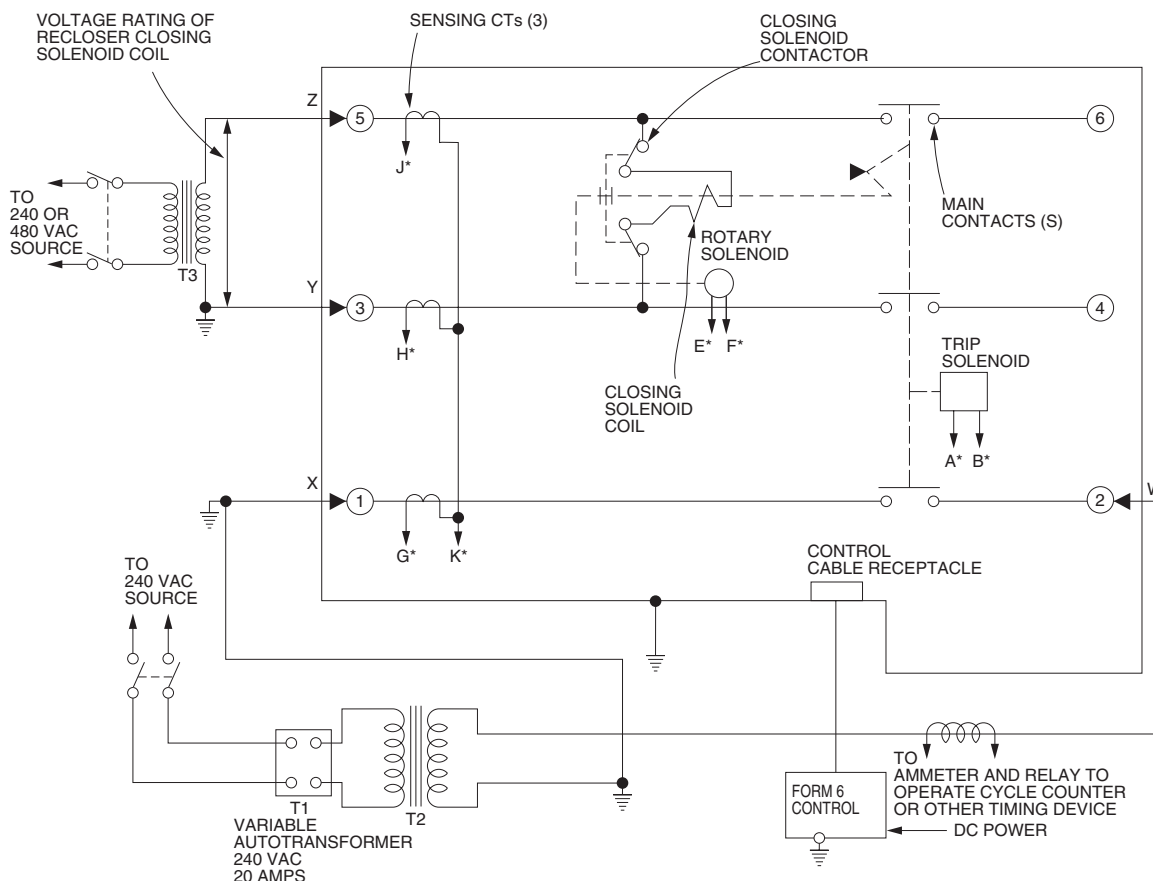

Figure 44.
Suggested test circuit for motor-operated, solenoid-closing reclosers with low-voltage closing.



*Indicates control cable receptacle pin/socket designation.

Figure 43.
Suggested test circuit for high voltage “shop-testing” solenoid-closing reclosers.

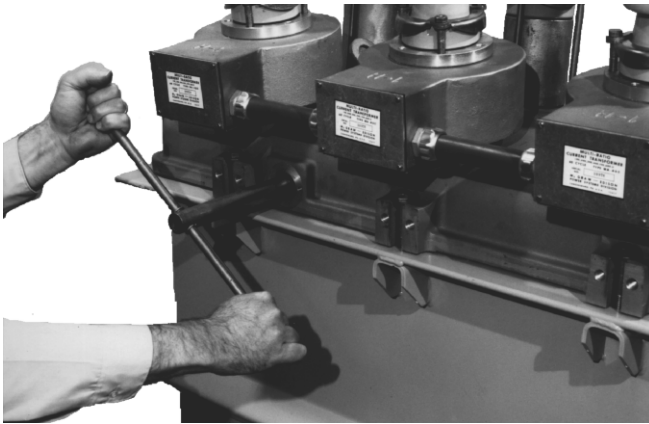

Figure 45.
Using a manual closing tool to operate the recloser.

82284KMA-F

Manual Closing — Solenoid-Operated Reclosers

WARNING: Explosion Hazard. Excessive Contact Arcing. Do not use the manual closing tool to close an oil-insulated energized recloser. Closing an energized oil-insulated recloser with a manual closing tool can cause excessive contact arcing, rapid build-up of gas within the equipment, and possible explosion that can cause death, severe personal injury, and equipment damage. T203.2

If high-voltage for operating the closing solenoid is not available, manual closing can be substituted for electrical closing. However, not all control settings can be checked since manual closing is not synchronized with the closing coil control circuit in the control.

Follow these steps to manually close the recloser:

1. Remove the closing tool port cover and gasket from the side of the recloser head casting.

CAUTION: Equipment damage. Do not turn the manual closing tool more than one-quarter turn clockwise. Forcing the tool beyond the mechanism stop may shear the pin on the closing shaft of the recloser. T222.0

2. Insert the tee-handled tool (available as an accessory) into the port, engaging the pin on the closing shaft (Figure 45).
3. Close the recloser by placing the yellow operating handle (located under the sleethood) into the up or CLOSED position and turning the closing tool one-quarter turn clockwise.
4. After each trip operation, about 1/2 second elapses while the closing solenoid plunger is moving upward to reset the main toggle latch.
5. After the main toggle latch resets, the recloser can be closed again by operating the manual closing tool.
6. Replace the gasket and port cover on the recloser head after testing has been completed.

Return the Control to Service

WARNING: This equipment is not intended to protect human life. Follow all locally approved procedures and safety practices when installing or operating this equipment. Failure to comply can result in death, severe personal injury, and equipment damage. G102.1

After the required work or testing is completed, follow this procedure to return the control to service:

CAUTION: Equipment misoperation. Do not connect this control to an energized recloser until all control settings have been properly programmed and verified. Refer to the programming information for this control. Failure to comply can result in control and recloser misoperation, equipment damage, and personal injury. G110.3

1. Verify that all control settings are correct prior to installation.

WARNING: Hazardous voltage. Recloser and control must be solidly grounded. Follow all locally approved procedures and safety practices when grounding this equipment. Improper grounding can result in contact with high voltage, which will cause death or severe personal injury. G115.1

2. Connect the ground to the control.

Note: Refer to **Grounding the Control** section.

WARNING: Hazardous voltage. If the recloser is energized while the control cable is disconnected, the CT secondaries can generate high voltages. Contact with high voltage can cause severe personal injury or death. T204.2

3. Connect control cable to the control.
4. Connect control ac sensing voltage to the control via disconnect switches.

Note: Refer to **Customer Connections for Dc Power and Ac Voltage Sensing** section.
5. Connect dc power to the control via disconnect switches.

Note: Refer to **Customer Connections for Dc Power and Ac Voltage Sensing** section.
6. The recloser and control are ready for service. Once installed, remove bypass switches on the recloser.
7. Disable GRD TRIP BLOCKED.
 - A. Press the CHANGE button on the Operator Panel to enter the CHANGE mode.
 - B. Depress the GRD TRIP BLOCKED button within ten seconds after entering the CHANGE mode.

Note: If the GRD TRIP BLOCK button is not depressed within ten seconds, the function is not activated.

ADDITIONAL INFORMATION

CAUTION: This equipment requires routine inspection and maintenance to ensure proper operation. If it is not maintained, it can fail to operate properly. Improper operation can cause equipment damage and possible personal injury. G105.1

Replacement Kits

Replacement kits for the Kyle Form 6 yard mount recloser control are available through the factory Service Department. To order these kits, refer to the Replacement Parts price list for catalog numbers and pricing. Contact your Cooper Power Systems representative for additional information and order procedures.

Factory-Authorized Service Centers

Factory-authorized service centers are located throughout the continental United States to provide maintenance, repair and testing services for Kyle controls and reclosers. For further information, contact your Cooper Power Systems representative.

Factory Testing and Troubleshooting Classes

The factory service department offers a basic testing and troubleshooting course for the Form 6 microprocessor-based recloser control. This course, taught by experienced service technicians, is held at the factory's in-house training facility. For additional information, contact your Cooper Power Systems representative.

Type MET Recloser Control Tester

A 30-minute video cassette program *KSPV7 Kyle® Type MET Electronic Recloser Control Tester Operation and Testing Procedures* is available as a supplemental training aid for service personnel.

