

Reclosers

Form 4C Recloser Control Protocol Conversion Kits KME4-589-7001, -7002, and -7003 Installation Instructions

Service Information
S280-77-11

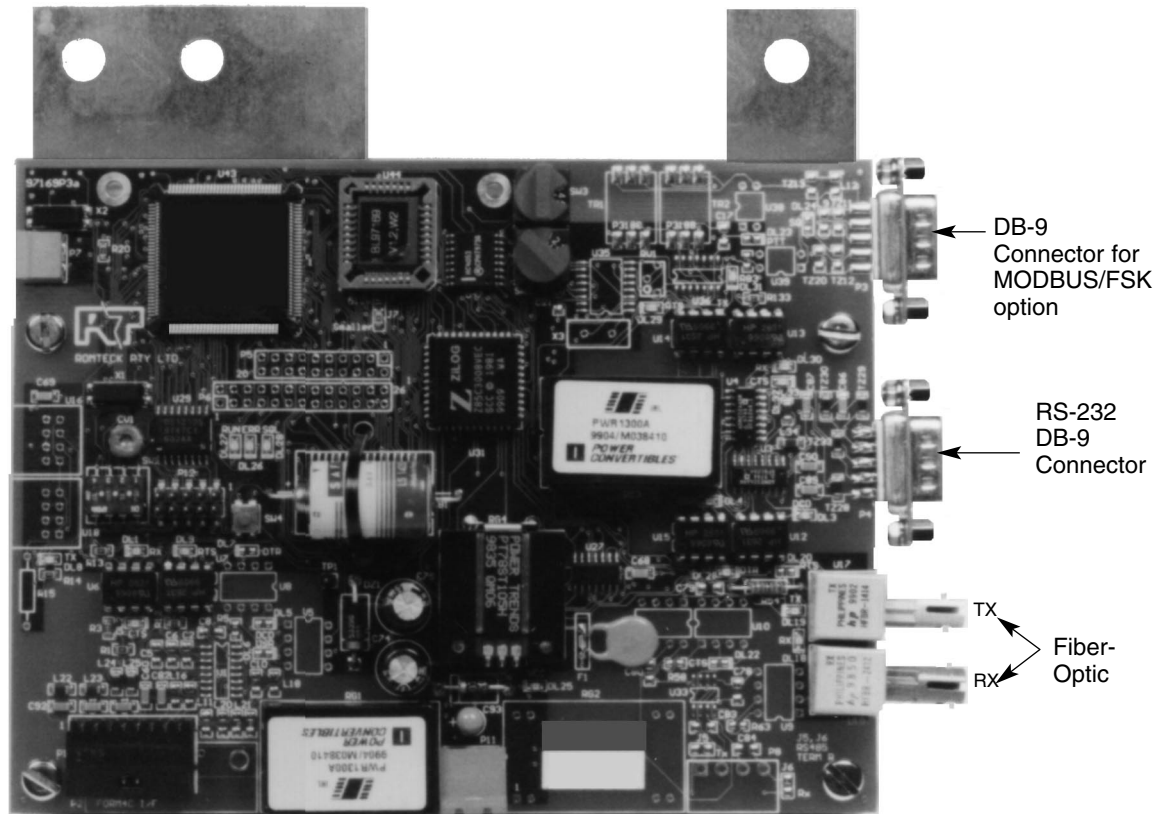

Figure 1. Form 4C Recloser Control Protocol Conversion Kit circuit board for 2179 Protocol Conversion to DNP, MOD-BUS protocol.

010029KM

Contents

Safety Information	2	Handling and Storage	3
Hazard Statement Definitions	2	Description	3
Safety Instructions	2	Installation	4
Product Information	3	To Remove Control From Service	4
Introduction	3	Protocol Conversion Kit	4
Read This Manual First	3	Testing	6
Additional Information	3	Fiber-Optic Cable Specifications	8
Quality Standards	3	Kit Parts	9
Acceptance and Initial Inspection	3		



SAFETY FOR LIFE



Cooper Power Systems products meet or exceed all applicable industry standards relating to product safety. We actively promote safe practices in the use and maintenance of our products through our service literature, instructional training programs, and the continuous efforts of all Cooper Power Systems employees involved in product design, manufacture, marketing, and service.

We strongly urge that you always follow all locally approved safety procedures and safety instructions when working around high voltage lines and equipment and support our “Safety For Life” mission.

SAFETY INFORMATION

The instructions in this manual are not intended as a substitute for proper training or adequate experience in the safe operation of the equipment described. Only competent technicians who are familiar with this equipment should install, operate, and service it.

A competent technician has these qualifications:

- *Is thoroughly familiar with these instructions.*
- *Is trained in industry-accepted high- and low-voltage safe operating practices and procedures.*
- *Is trained and authorized to energize, de-energize, clear, and ground power distribution equipment.*
- *Is trained in the care and use of protective equipment such as flash clothing, safety glasses, face shield, hard hat, rubber gloves, hotstick, etc.*

Following is important safety information. For safe installation and operation of this equipment, be sure to read and understand all cautions and warnings.

Safety Instructions

Following are general caution and warning statements that apply to this equipment. Additional statements, related to specific tasks and procedures, are located throughout the manual.

⚠ DANGER: Hazardous voltage. Contact with hazardous voltage will cause death or severe personal injury. Follow all locally approved safety procedures when working around high and low voltage lines and equipment.

G103.3

⚠ WARNING: Before installing, operating, maintaining, or testing this equipment, carefully read and understand the contents of this manual. Improper operation, handling or maintenance can result in death, severe personal injury, and equipment damage.

G101.0

⚠ WARNING: This equipment is not intended to protect human life. Follow all locally approved procedures and safety practices when installing or operating this equipment. Failure to comply can result in death, severe personal injury, and equipment damage.

G102.1

⚠ WARNING: Power distribution equipment must be properly selected for the intended application. It must be installed and serviced by competent personnel who have been trained and understand proper safety procedures. These instructions are written for such personnel and are not a substitute for adequate training and experience in safety procedures. Failure to properly select, install, or maintain power distribution equipment can result in death, severe personal injury, and equipment damage.

G122.2

Hazard Statement Definitions

This manual may contain four types of hazard statements:

⚠ DANGER: Indicates an imminently hazardous situation which, if not avoided, will result in death or serious injury.

⚠ WARNING: Indicates a potentially hazardous situation which, if not avoided, could result in death or serious injury.

⚠ CAUTION: Indicates a potentially hazardous situation which, if not avoided, may result in minor or moderate injury.

⚠ CAUTION: Indicates a potentially hazardous situation which, if not avoided, may result in equipment damage only.

PRODUCT INFORMATION

Introduction

Service Information S280-77-11 provides installation instructions for the Form 4C Protocol Converter Accessory kit. This accessory kit enables the use of additional communication protocols to meet application needs. This kit contains a protocol board with required hardware and wiring sub-assemblies.

For additional information related to the installation and operation of the Form 4C control, refer to *S280-77-1 Form 4C Microprocessor-Based Recloser Control Installation and Operation Instructions*.

For programming instructions, refer to *S280-77-4 Form 4C Microprocessor-Based Recloser Control Programming Guide*.

Read This Manual First

Read and understand the contents of this manual and follow all locally approved procedures and safety practices before installing and operating this equipment.

Additional Information

These instructions do not claim to cover all details or variations in the equipment, procedures, or process described, nor to provide directions for meeting every possible contingency during installation, operation, or maintenance. When additional information is desired to satisfy a problem not covered sufficiently for the user's purpose, contact your Cooper Power Systems representative.

Quality Standards

The Quality System at the Cooper Power Systems, Kyle Distribution Switchgear plant is certified to the ISO 9001 standard.

Acceptance and Initial Inspection

Each accessory is tested and inspected at the factory. It is in good condition when accepted by the freight carrier for shipment.

Upon receipt, thoroughly inspect the accessory for damage incurred during shipment. If damage is discovered, file a claim with the carrier immediately.

Handling and Storage

CAUTION: Equipment damage. Always wear a grounding wrist strap to control static electricity before handling circuit boards. Failure to use this strap may result in circuit board damage.

T253.1

This kit includes a grounding wrist strap designed to control static electricity (Figure 2). Be certain to wear the wrist strap before unpacking and during the installation of the protocol board accessory. Failure to use a grounding wrist strap may result in damage to the protocol board(s).

Following are instructions specific to using the grounding wrist strap:

1. Unwrap the first two folds of the strap and place the exposed adhesive side firmly around your wrist.
2. Unroll the rest of the strap and peel the liner from the copper foil at the opposite end.
3. Attach the copper foil end to a clean area on the grounded back-panel inside the control cabinet.

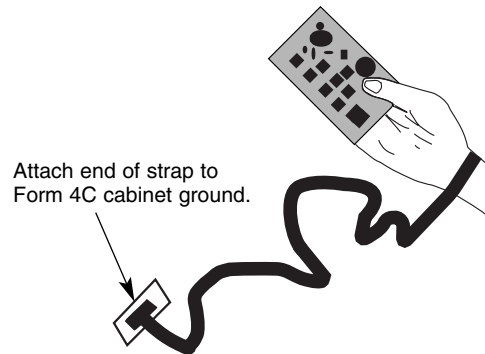

Figure 2.
Correct use of grounding strap.

If this accessory will be stored for any appreciable time, place circuit board assembly in static-proof bag and store it and all other items in a clean, dry storage area.

Description

The function of the protocol converter is to interface between the Form 4C Control (native 2179 protocol) and a host system of DNP or MODBUS protocol.

The protocol converter is a DTE device and is connected to a radio or modem (DCE device) with a straight DB-9 connector (RS-232).

The DNP version is equipped with a terminal program which allows access to DNP and advanced communications parameters as defined in the *R280-90-16 DNP3 Device Profile, Release 2.0*. Connection from the PC to protocol converter is made through a null modem.

INSTALLATION

IMPORTANT: The Form 4C control must be removed from service and transported to a clean and suitably equipped service center prior to the kit installation process.

To Remove Control From Service

The following steps must be taken to remove the control from service and prevent possible recloser misoperation.

1. Switch Ground Trip Block switch to BLOCK.
2. Disconnect control cable from the control.
3. De-energize ac power from the control.
4. Unplug the control battery.

Protocol Conversion Kit

Circuit Board Installation

The protocol communications accessory circuit board mounts to the bracket, which is part of the Form 4C battery-supply shelf.

The following procedure should be used to install the Form 4C accessory circuit board. For additional information, refer to *Service Information S280-77-1 Form 4C Microprocessor-Based Recloser Control Installation and Operation Instructions*.

A linear (standard) power supply can be used if the application will not be equipped with a radio.

Note: When using the linear (standard) power supply, discard the red/black twisted-pair wire (Item 6) included with the kit. This is not used with linear (standard) power supplies.

Note: When using the automation power supply, discard the orange/brown wire (Item 9) included with the kit. This is not used with automation power supplies.

CAUTION: Recloser misoperation. The control must be removed from service prior to performing any maintenance, testing, or programming changes. Failure to comply can result in misoperation (unintentional operation) of the recloser.

T216.2

1. Remove the Form 4C Recloser Control from service. Refer to *S280-77-1 Form 4C Microprocessor-Based Recloser Control Installation and Operation Instructions* for additional information.

CAUTION: Control damage. De-energize both ac and dc power prior to removing or installing any internal connections or circuit boards in the control. Failure to comply can result in damage to the control.

T241.1

2. Completely de-energize the control by disconnecting all ac and dc voltages to the control box.

3. Carefully transport the control to a suitable service facility.

Note: The entire kit assembly/installation process should be conducted in a clean environment, such as a repair shop.

4. Open the control front panel by turning two spring-loaded wing studs.

5. Locate the four wing nuts that fasten the battery hold-down brackets to control box.

Note: On later models, there are two additional empty studs to be used for board installation. On earlier models, remove the second and fourth wing nuts and lockwashers. This hardware *will not* be reused for board installation.

CAUTION: Equipment damage. Always wear a grounding wrist strap to control static electricity before handling circuit boards. Failure to use this strap may result in circuit board damage.

T253.1

6. Refer to the **Handling and Storage** section of this manual before continuing with board installation. Carefully remove the protocol communications board accessory from the static-proof bag.

7. With circuit board components facing out, install the board to the mounting studs (Figure 3). Secure board with the supplied wingnuts and washers. Tighten hardware securely.

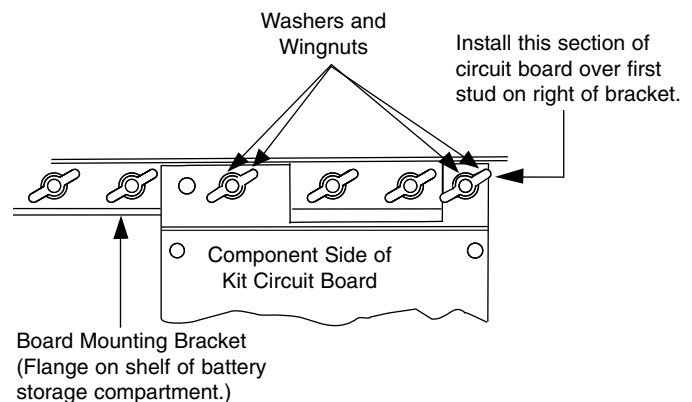

Figure 3.
Accessory circuit board mounting.

8. Connect wires (either red/black or orange/brown) between power supply and protocol board. Wire color is dependent upon the type of power supply in the Form 4C control. Follow the applicable instructions:

• **Form 4C Control with the Automation Power Supply: Use red/black twisted pair wire (Item 6).**

- A. Strip leads at one end of supplied twisted-pair wire (red/black) to expose 6 mm (1/4 inch) of bare wire.
- B. Fasten stripped wires to terminal P3 on power supply.
- C. Route red/black wire to P11 on new communication board and strip wire ends as stated in first step.
- D. Insert wire into P11 with the red wire to the + side. Refer to Figure 4 for polarity orientation.

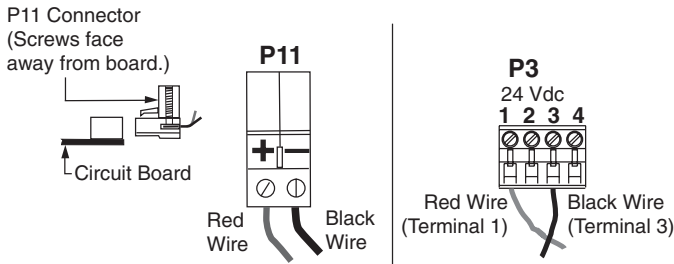

Figure 4.
Terminal connections of red/black twisted pair wire.
(Applicable to the automation power supply only.)

• **Form 4C Control with the Linear (Standard) Power Supply: Use orange/brown wire (Item 9).**

- A. Disconnect the orange/brown wire from the power supply to the optional I/O board. Discard wire. See Figure 5.
 - B. Replace discarded wiring with kit-supplied yellow/brown wiring. Connect end plug to power supply and second plug to optional input/output board.
 - C. Route the remaining brown and orange leads to P11 on communications protocol board.
- Note:** If required, strip both wires to expose 6.4 mm (1/4 inch) of bare wire.
- D. Connect stripped areas of wires to P11 with orange wire to + side of connector. Refer to Figure 5.

9. Connect the interface cable as follows:

Note: The interface cable has a connector at each end. One end also has a protruding ground wire.

- A. Insert the cable end without the ground wire into P2 on the protocol conversion circuit board.
- B. Connect the cable end with ground wire to P20, located on the lowest board attached to the swing panel (Figure 6).

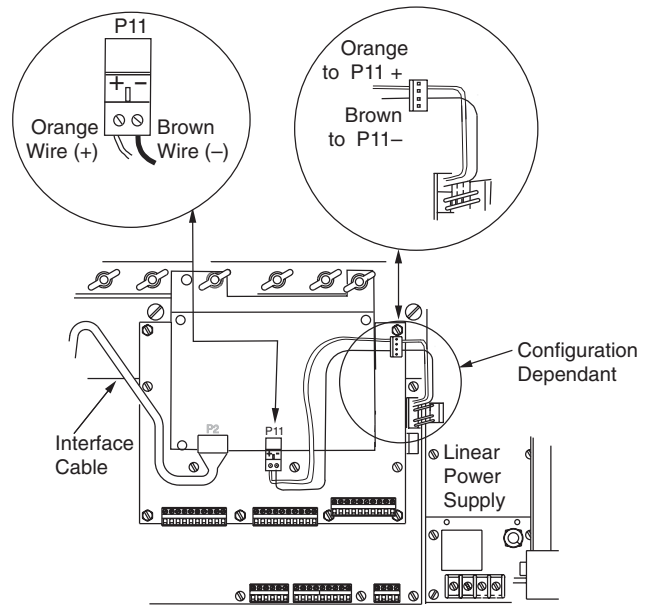

Figure 5.
Connection of orange/brown wire. (Applicable to the linear (standard) power supply only.)

- C. Route the cable as shown in Figure 6 with the provided wire ties (Item 7) to secure it to existing cabling.
- D. Connect the ground wire to swing panel (Figure 6).

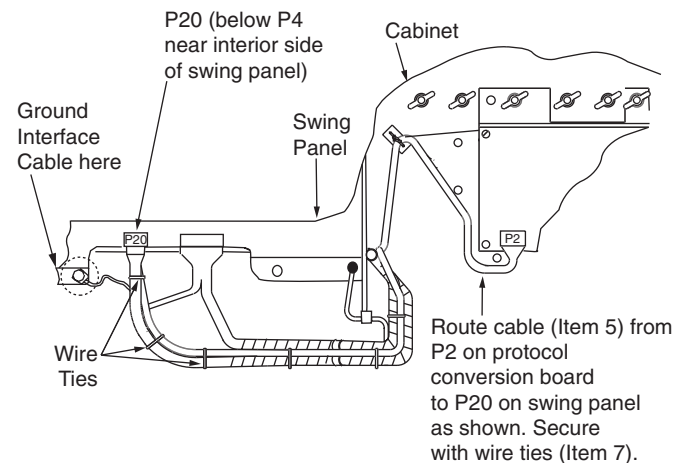

Figure 6.
Placement of interface cable.

- 10. Attach the communications protocol identification label to the inside of swing panel door.
- 11. Review to make sure all components are installed correctly. Ensure all wires are fastened securely. Proceed to **Set Point Configuration** section of this manual.

Set Point Configuration

IMPORTANT: All installation procedures must be completed prior to beginning Set Point Configuration. Refer to the **Installation** section of this manual.

MODBUS/FSK Option

Protocol boards with MODBUS/FSK option require no additional configuration.

Fiber-Optic/RS-232 Option

Refer to Figure 7 for location of set point switches on protocol board with Fiber-Optic/RS-232 options.

Set Communications Mode

A bank of four dipswitches (SW1) configures the control external communication mode. Set Dipswitch 1 to appropriate settings for hardware to be used (RS-232/Fiber-Optic). Then, select the appropriate baud rate to communicate with the RTU by adjusting SW3. Refer to Table 3 for proper settings. Table 1 depicts mode settings.

TABLE 1
Dipswitch SW1 – Communication Modes

Dipswitch	4	3	2	1
RS-232	Off	Off	*	*
Fiber-Optic Non-Echo	Off	On	*	*
Fiber-Optic Echo	On	Off	*	*

* Not used for these settings.

Switch SW2 Control Selection

TABLE 2
Rotary Switch SW2 – Control Selection

Setting	Control Type
0	Voltage Regulators
1	Voltage Regulator/MJX Mode
2	Form 4C Control

Rotary Switch SW3 Baud Rate Settings

When SW1 dipswitch 1 is set to ON, set baud rates through local or remote computers or other devices.

When SW1 dipswitch 1 is set to OFF, manually set baud rates using rotary switch SW3. Table 3 depicts baud rates for switch SW3 settings.

TABLE 3
Rotary Switch SW3 – Baud Rate Settings

Settings	Baud Rate
0	300
1	1200
2	2400
3	4800
4	9600
5	19200

Run LED Indicator

Run LED indicator (Figure 7) blinks when communications are operating normally.

Reset Button

When activated, this momentary push-button initiates a reset of the microprocessor on the communications board.

TESTING



CAUTION: Equipment misoperation. Do not connect this control to an energized recloser until all control settings have been properly programmed and verified. Refer to the programming information for this control. Failure to comply can result in control and recloser misoperation, equipment damage, and personal injury.

G110.3

Refer to *S280-77-1 Form 4C Microprocessor-Based Recloser Control Installation and Operation Instructions* and *S280-77-4 Form 4C Microprocessor-Based Recloser Control Programming Guide* for testing procedures prior to returning the control to service.

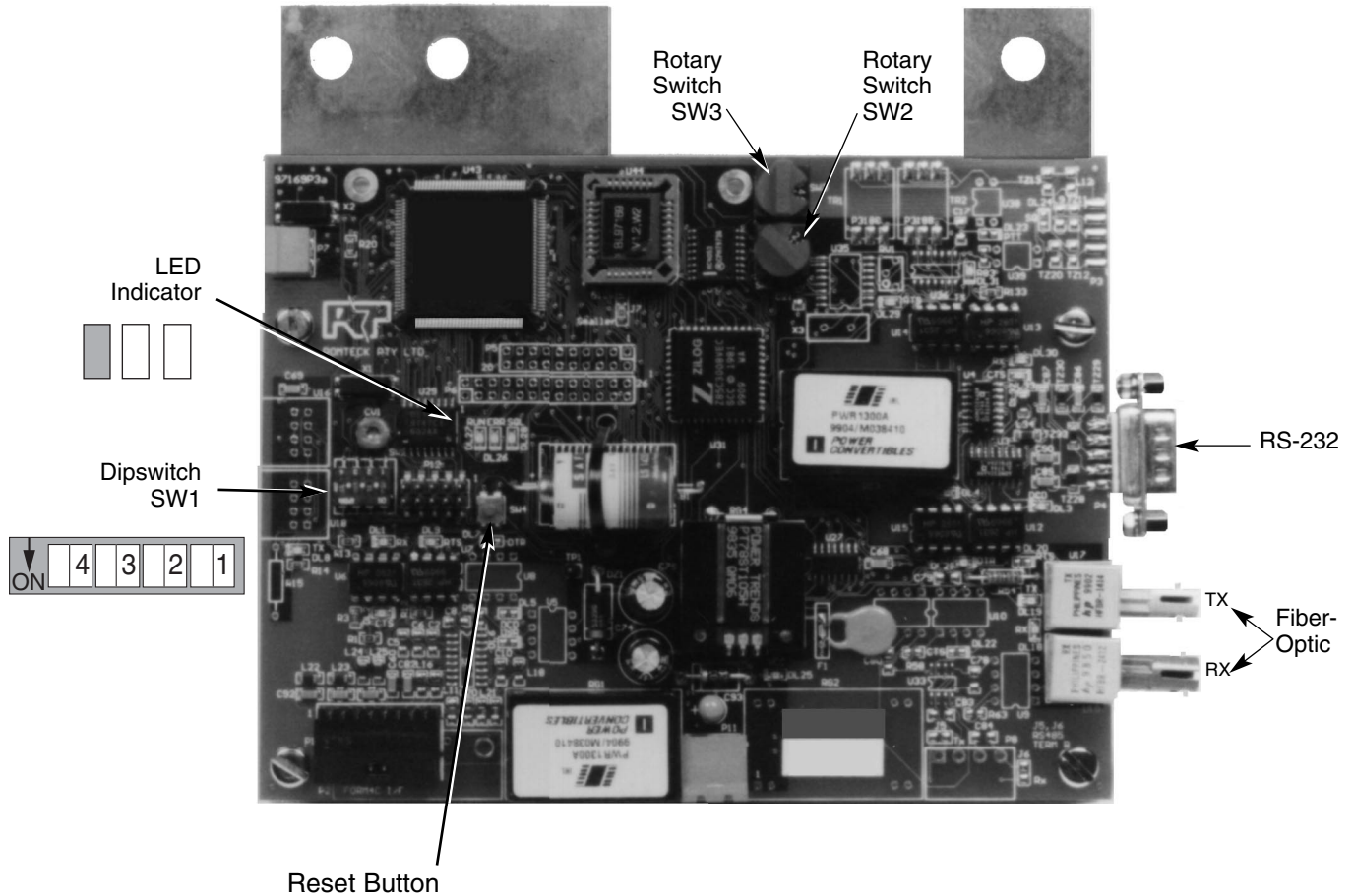

Figure 7. Communications protocol board configured for RS-232 and fiber-optic communications.

010070KM

LEGEND
Protocol Board Switches and Indicators

Description	Function
Dipswitch SW1	Select communications parameters.
Rotary Switches SW2 SW3	Select type of control. Set baud rate.
LED indicator	Indicate RUN status.
Reset button	Initiate reset of microprocessor on communications board.

FIBER-OPTIC CABLE SPECIFICATIONS

Construction

Multi-mode glass fiber-optic cable suitable for direct burial and/or outdoor use.

Specifications

1. Operating Temp. Range: -40°C to +65°C
2. Strength Member: KEVLAR®

NOTE: The strength member cannot be steel or any other conductive material as electrical isolation will be lost.

3. Inner Jacket: PVC
4. Outer Jacket: Polyethylene
5. Optical window: 850 nanometers (nm).
6. Core size: 62.5 microns (µm).

Other core sizes are allowable; however, they will affect the output power of the optical transmitter. See **Maximum Cable Lengths** section.

7. Attenuation at 850 nm: 3.5 dB/km

Cables with different attenuations are acceptable; however, maximum allowable cable length will be affected. See **Maximum Cable Lengths** section for an example of how to calculate maximum permissible cable length.

Cable Terminations

“ST” style connectors must be used to mate with the KME4-142 fiber-optic circuit board and the KME4-163 fiber-optic to EIA-232D converter.

Maximum Cable Lengths

1. The maximum cable length depends on the output power of the transmitter, the input power level that the receiver can detect as well as the attenuation of the fiber-optic cable.
2. The Form 4C control has used two different style transmitters, the HFBR-1412 and the high efficiency HFBR-1414. The HFBR-1414 transmitter went into production on 3-19-91, serial number 200925. The output power of the transmitter is dependent on the fiber-optic core size.

Fiber Core Size	Output Power P(dBm)*	
	HFBR-1414	HFBR-1412
50.0 µm	-20.5	-23.5
62.5 µm	-16.0	-20.0
100.0 µm	-10.5	-16.0
200.0 µm	- 5.5	-11.0

*P (dBm) = 10 log (PµW/1000)

3. Cable length calculation example:

Typical 62.5 µm fiber cable attenuation:..... 3.5 dB/km
 HFBR-1412 Transmitter,
 Output Power: -20.0 dBm
 HFBR-2412 Receiver,
 Input Level: -24.0 dBm
 Safety Margin: -1.5 dBm
 Budget for Cable:
 -24.0 dBm - (-20 dBm) - (-1.5 dBm) = -2.5 dBm

Max. Cable Length = $\frac{-2.5 \text{ dBm}}{-3.5 \text{ dB/km}} = 0.71 \text{ km}$

