



APPENDIX I

Figure 37a and 37b Schematic Diagram of Form 2 ..14, 15
Figure 38a and 38b Schematic Diagram of Form 3
and RE/WE Recloser16, 17
Figure 39a and 39b Schematic Diagram of form 3
and Motor Operated Recloser.....18, 19
Figure 40a and 40b Schematic Diagram of Form 3A
and RE/WE Recloser20, 21
Figure 41a and 41b Schematic Diagram of Form 3A
and Motor Operated Recloser.....22, 23

This manual S280-75-46 has three parts:

S280-75-46Apages 1 - 12

S280-75-46Bpages 13 - 19

S280-75-46Cpage 20 - 24

For the complete manual (pages 1 - 12) refer to S280-75-46A, (pages 20 - 24) refer to S280-75-46C.

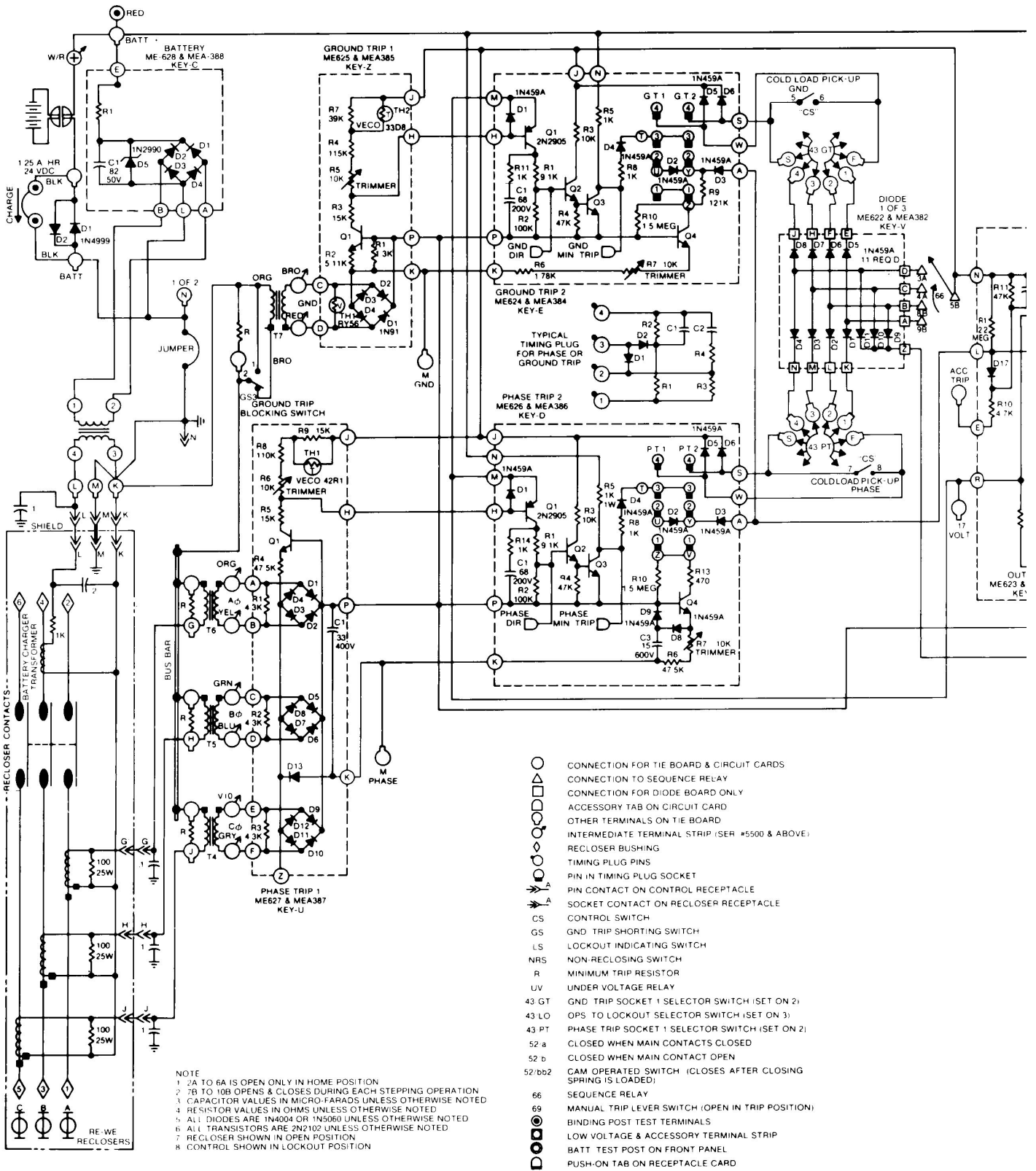

Figure 38a. Schematic diagram of Form 3 and RE/WE recloser (page 1 of 2).

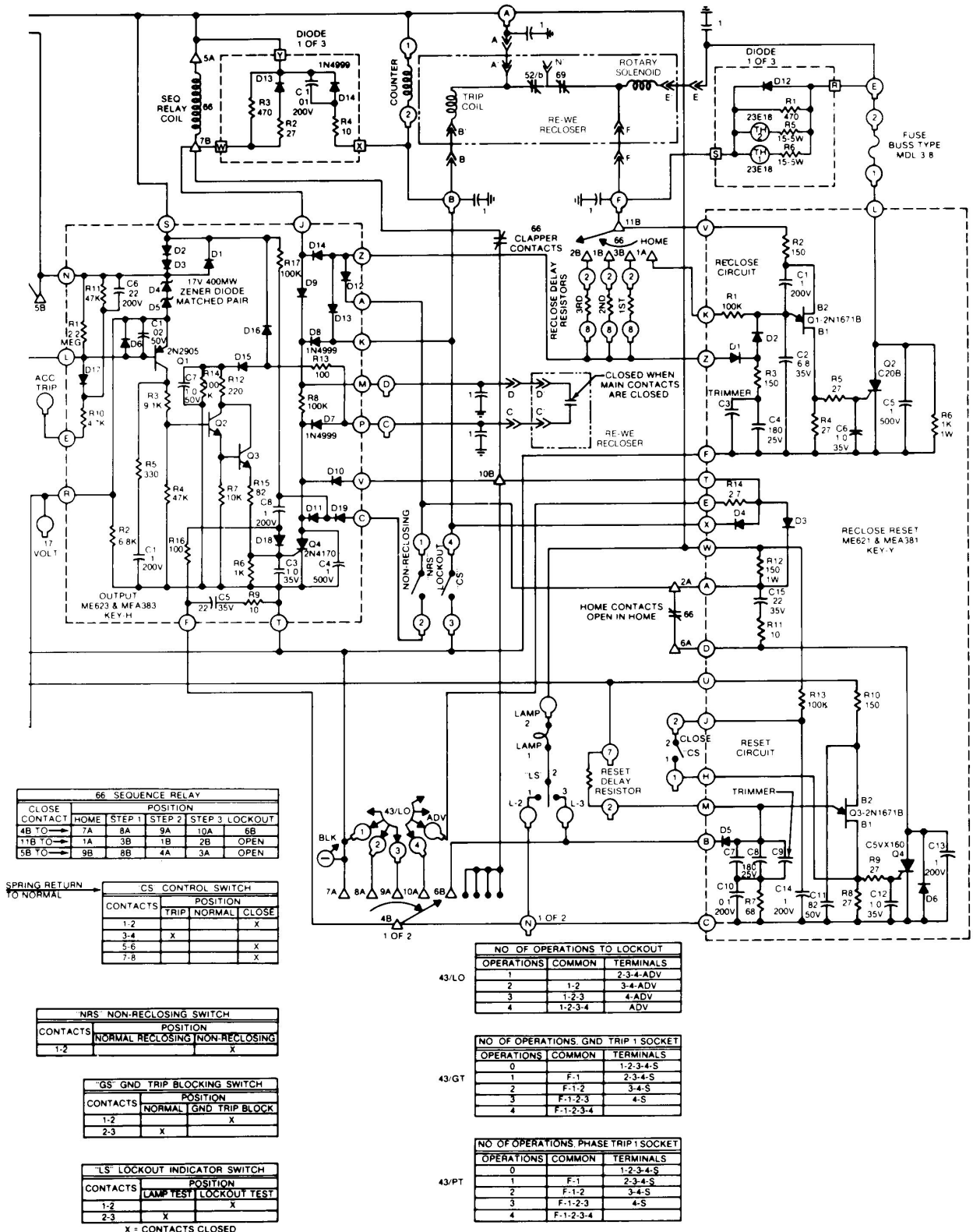

Figure 38b. Schematic diagram of Form 3 and RE/WE recloser (page 2 of 2).

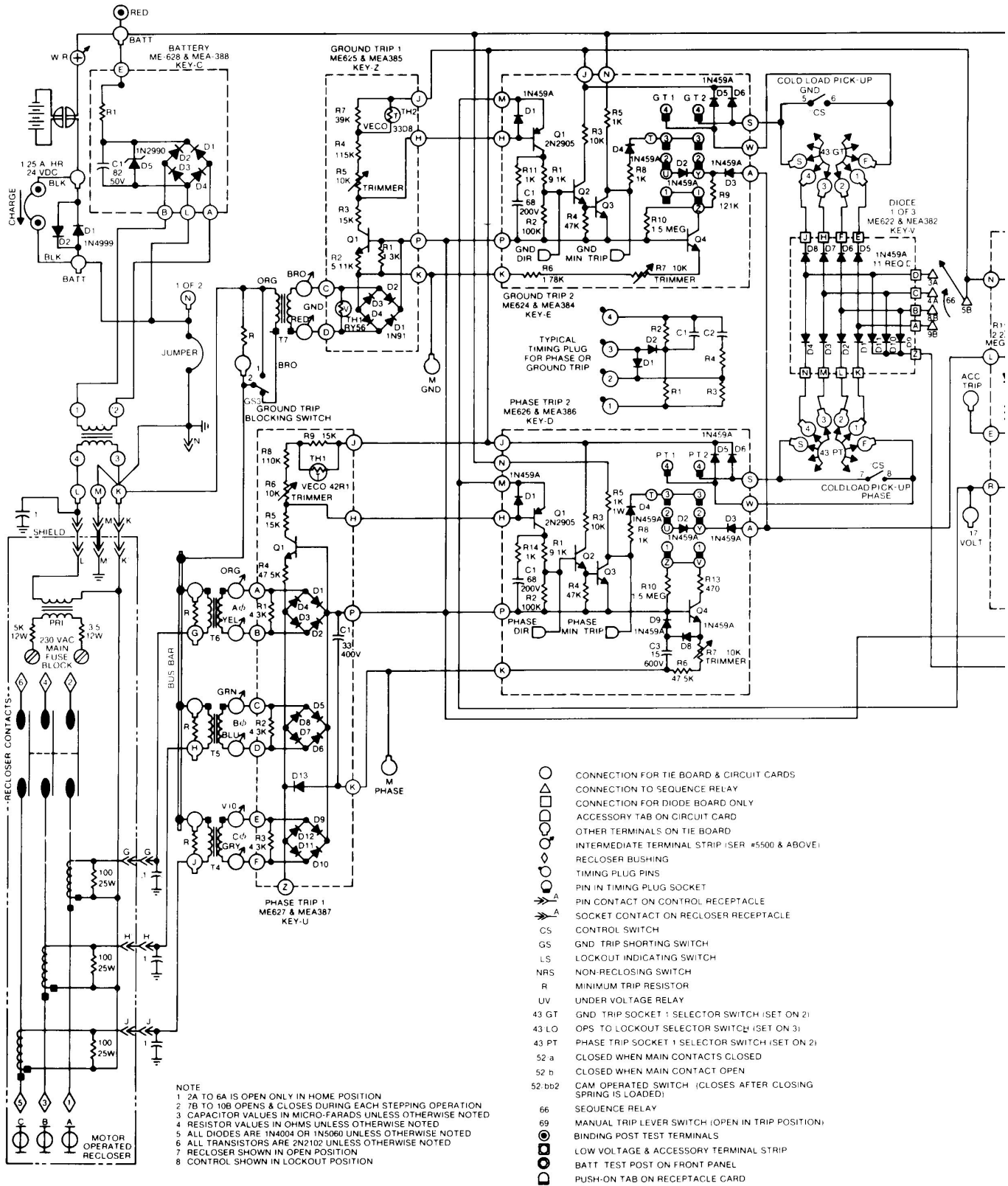

Figure 39a. Schematic diagram of Form 3 and motor operated recloser (page 1 of 2).

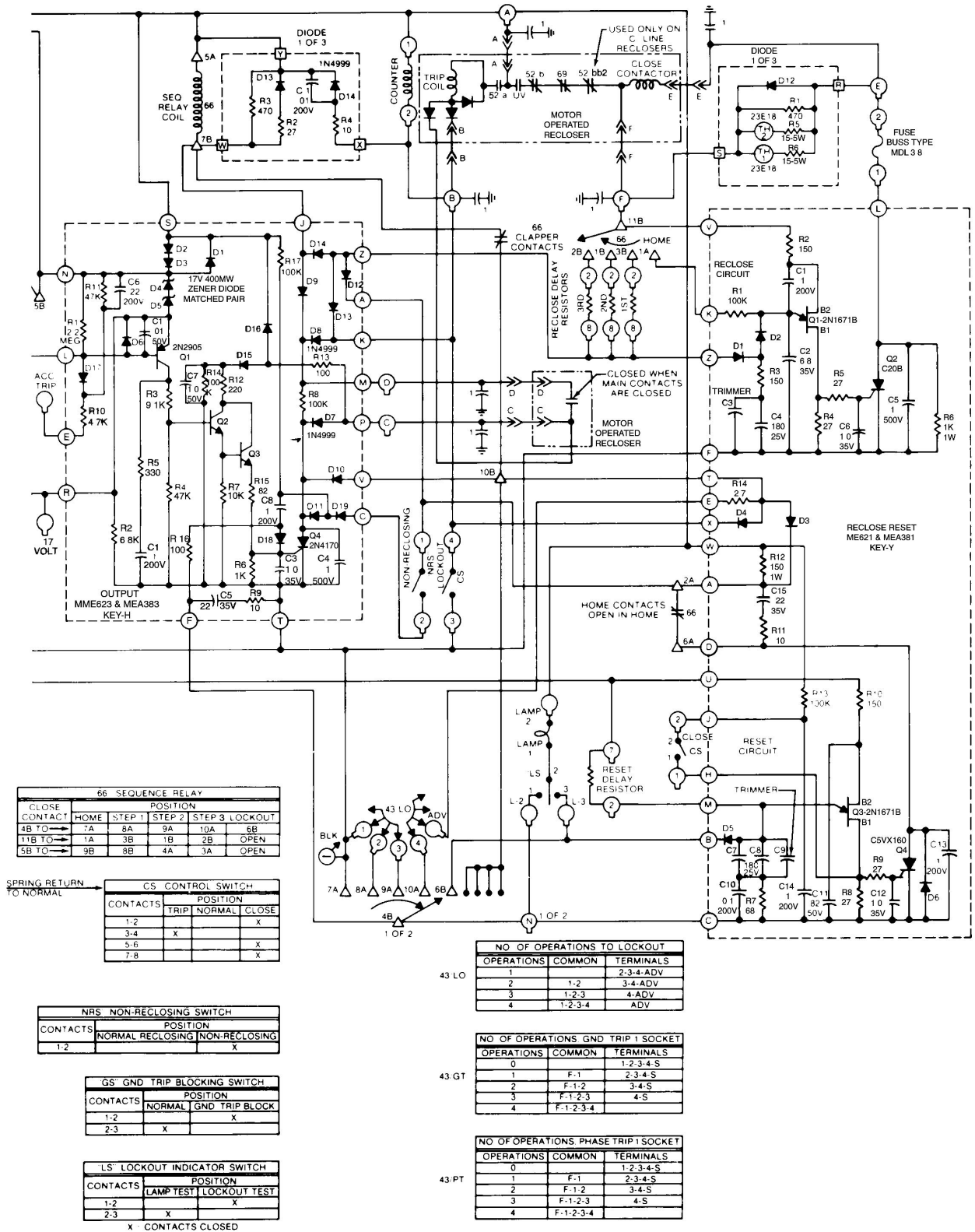

Figure 39b. Schematic diagram of Form 3 and motor operated recloser (page 2 of 2).