

Type ME Electronic Recloser Control Maintenance - Advanced Circuitry

Applicable to Form 3 and 3A Controls

CONTENTS

| | |
|--|--------|
| Introduction | 1 |
| Basic Circuit Design | 1 |
| Typical Schematic Symbols | 1 |
| ME Control Circuits | 4 |
| Control Circuitry Analysis | 8 |
| Potential Battery Circuit | 8 |
| Closing From Lockout Circuit | 8 |
| Sensing Circuit | 8 |
| Voltage Level Detector Circuit | 9 |
| Voltage Level Detector and Timing Circuit | 9 |
| Output Board Circuit | 11 |
| Reclose Board Circuit | 11 |
| Reset Circuit | 11 |
| Appendix I | 13 |
| Schematic Diagram of Form 2 | 14, 15 |
| Schematic Diagram of Form 3 and RE/WE Recloser | 16, 17 |
| Schematic Diagram of Form 3 and Motor operated Recloser | 18, 19 |
| Schematic Diagram of Form 3A and RE/WE Recloser | 20, 21 |
| Schematic Diagram of Form 3A and Motor operated Recloser | 22, 23 |
| Appendix II | 24 |
| List of Electronic Control Accessory Manuals Containing Schematic Diagrams | 24 |

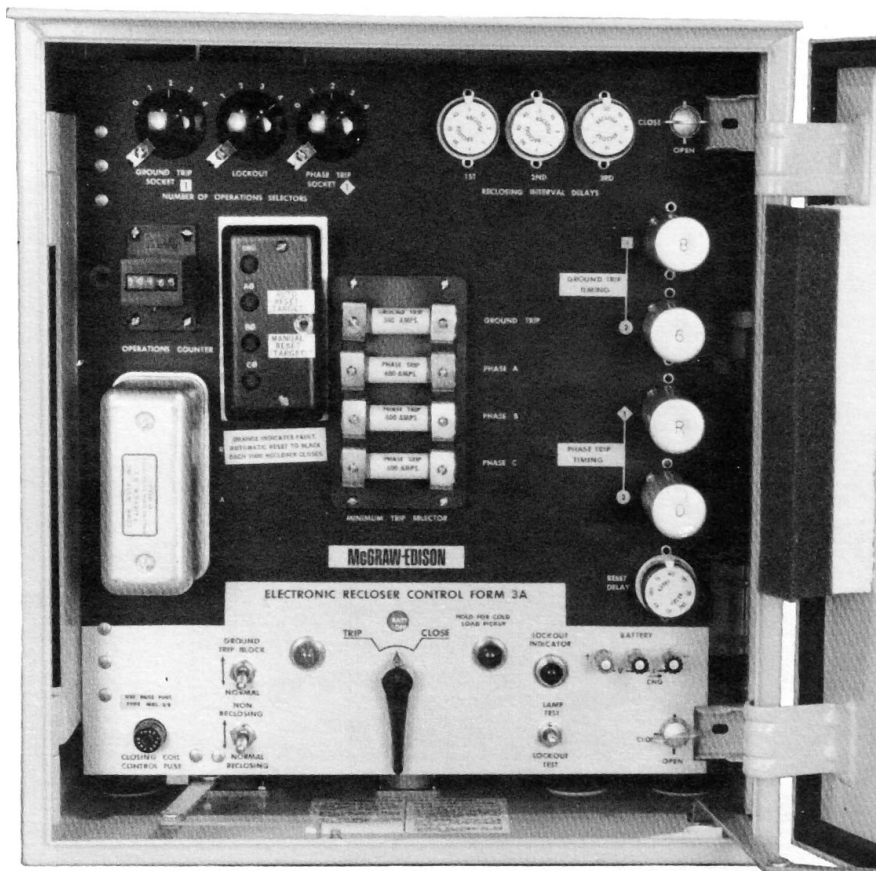

Figure 1. Type ME electronic recloser control.

INTRODUCTION

Service Information S280-75-46 details the major electronic components and circuits of the Type ME electronic control (figure 1). A general description of the control and its operating principles, as well as basic inspection, testing, and maintenance instructions, is found in Service Information S280-75-1. In addition, basic maintenance instructions for the ME control are found in Service Information S280-75-2. Before proceeding with this manual, be sure you have a thorough understanding of both these manuals (S280-75-1 and S280-75-2).

BASIC CIRCUIT DESIGN

A detailed study of ME control circuitry requires a common understanding of basic electronic components and simple circuits that can be built from these components. Thus, to assure this com-

mon knowledge — simple electronic components will be reviewed, followed by the study of basic electronic circuitry.

Typical Schematic Symbols

In the electronic control, the resistor is shown in two forms . . . a rectangular block or a sawtooth line (figure 2). Resistors are introduced into a circuit to reduce voltage and limit current flow.

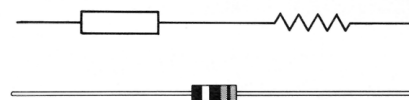

Figure 2. Resistor symbol.

These instructions do not claim to cover all details or variations in the equipment, procedure, or process described, nor to provide direction for meeting every possible contingency during installation, operation, or maintenance. When additional information is desired to satisfy a problem not covered sufficiently for the user's purpose, please contact your Cooper Power Systems sales engineer.



SAFETY FOR LIFE



Cooper Power Systems products meet or exceed all applicable industry standards relating to product safety. We actively promote safe practices in the use and maintenance of our products through our service literature, instructional training programs, and the continuous efforts of all Cooper Power Systems employees involved in product design, manufacture, marketing, and service.

We strongly urge that you always follow all locally approved safety procedures and safety instructions when working around high voltage lines and equipment and support our “Safety For Life” mission.

SAFETY INFORMATION

The instructions in this manual are not intended as a substitute for proper training or adequate experience in the safe operation of the equipment described. Only competent technicians who are familiar with this equipment should install, operate, and service it.

A competent technician has these qualifications:

- *Is thoroughly familiar with these instructions.*
- *Is trained in industry-accepted high- and low-voltage safe operating practices and procedures.*
- *Is trained and authorized to energize, de-energize, clear, and ground power distribution equipment.*
- *Is trained in the care and use of protective equipment such as flash clothing, safety glasses, face shield, hard hat, rubber gloves, hotstick, etc.*

Following is important safety information. For safe installation and operation of this equipment, be sure to read and understand all cautions and warnings.

Safety Instructions

Following are general caution and warning statements that apply to this equipment. Additional statements, related to specific tasks and procedures, are located throughout the manual.

 **DANGER:** Hazardous voltage. Contact with hazardous voltage will cause death or severe personal injury. Follow all locally approved safety procedures when working around high and low voltage lines and equipment. G103.3

 **WARNING:** Before installing, operating, maintaining, or testing this equipment, carefully read and understand the contents of this manual. Improper operation, handling or maintenance can result in death, severe personal injury, and equipment damage. G101.0

 **WARNING:** This equipment is not intended to protect human life. Follow all locally approved procedures and safety practices when installing or operating this equipment. Failure to comply can result in death, severe personal injury, and equipment damage. G102.1

 **WARNING:** Power distribution equipment must be properly selected for the intended application. It must be installed and serviced by competent personnel who have been trained and understand proper safety procedures. These instructions are written for such personnel and are not a substitute for adequate training and experience in safety procedures. Failure to properly select, install, or maintain power distribution equipment can result in death, severe personal injury, and equipment damage. G122.2

Hazard Statement Definitions

This manual may contain four types of hazard statements:

 **DANGER:** Indicates an imminently hazardous situation which, if not avoided, will result in death or serious injury.

 **WARNING:** Indicates a potentially hazardous situation which, if not avoided, could result in death or serious injury.

 **CAUTION:** Indicates a potentially hazardous situation which, if not avoided, may result in minor or moderate injury.

CAUTION: Indicates a potentially hazardous situation which, if not avoided, may result in equipment damage only.

The **capacitor** is shown in schematic form by two plates. one plate is shown curved to distinguish it from contacts (figure 3). Capacitors are introduced into a circuit to oppose changes in voltage and/or store energy in an electrostatic field.

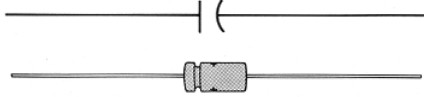

Figure 3.
Capacitor symbol.

A simple **manually operated contact** is shown in figure 4 (may be shown with a dotted line if connected in gang with several other contacts). Contacts are introduced into a circuit to allow the opening or closing of a circuit.

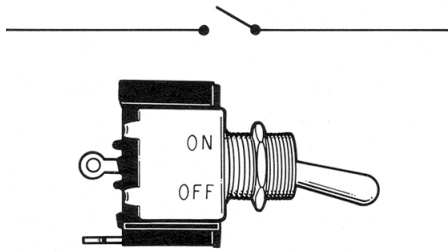

Figure 4.
Manual switch symbol.

Mechanically or electrically operated contacts are shown in a schematic (figure 5) as parallel lines when normally open (N.O.)* or as parallel lines with a slash when normally closed (N.C.). These contacts allow for mechanical and/or electrical coordination and control of circuit position.

*Normally open contact—contact state with its operating device (coil, spring, etc) in deenergized position.

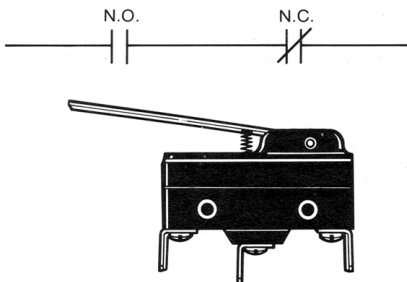

Figure 5.
Mechanical or electrical contact symbol.

The symbol for a **diode** is shown in figure 6. A diode can be introduced into a circuit to allow current flow in one direction only. The operation of the diode is shown in figure 7. In a circuit consisting of a voltage source, a resistor, and a diode, the current in the circuit is $I = E/R$ (figure 7A). If the diode is inverted (blocking position) as shown by figure 7B, the current in the circuit is zero. When current flows through a diode, a nearly constant 0.7 volt drop from anode to cathode is present.

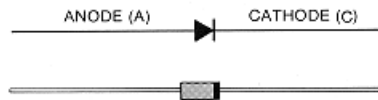

Figure 6.
Diode symbol.

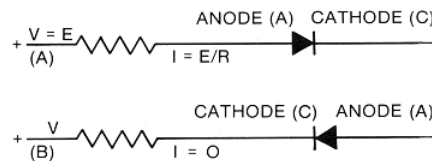

Figure 7.
Diode operation.

An electronic device used as a voltage regulator is the **zener diode**. Its schematic symbol is shown in figure 8. The zener diode is also commonly used as a voltage reference. In the simple circuit shown in figure 9, the 10-volt zener diode will always subtract ten volts from the 25-volt source producing a 15-volt output. This output voltage is essentially independent of the current to the zener diode. The difference between battery plus and the voltage on the anode of the zener diode will always remain 10 volts. The variations in the tolerance of the resistor and variations in the battery voltage itself will not affect this constant value.

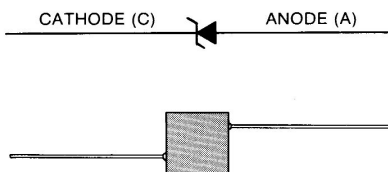

Figure 8.
Zener diode symbol.

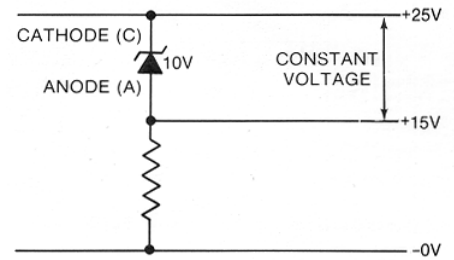

Figure 9.
Zener diode operation.

The **NPN transistor** symbol is shown in figure 10. It has a collector, a base and an emitter. The base is the normal controlling element for the transistor. A collector might be said to collect the current into the transistor. The emitter, which carries current that is common to the base and the collector, can be said to emit the current from the transistor. The transistor's primary purpose in a circuit is to amplify current or switch current on or off.

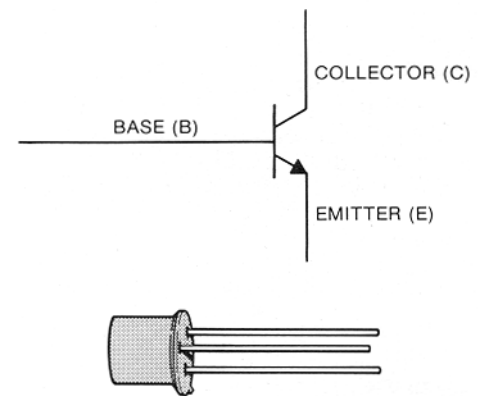

Figure 10.
NPN transistor symbol.

The **PNP transistor** (figure 11) differs from the NPN transistor where the emitter, rather than emitting current from the transistor, emits current into the transistor. Except for this variation, everything said about the NPN transistor applies to the PNP transistor.

NOTE: The input signal at the base for the PNP transistor is commonly referenced back to battery plus, where the base for the NPN is connected to battery minus. This provides extra flexibility in designing transistorized circuitry.

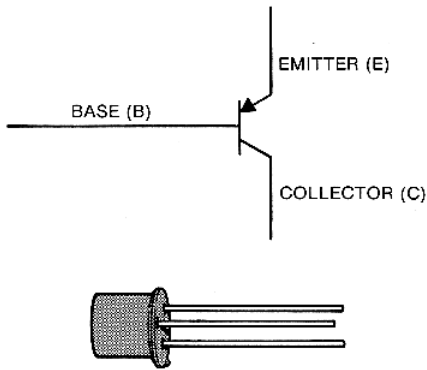

Figure 11. PNP transistor symbol.

The **unijunction transistor (UJT)** (figure 12) is a voltage detecting and switching element. As its name (uni-junction) implies, it consists of but one junction, an emitter connected to a base. However, it is still a three-terminal device in that the base has two leads: one normally connected to battery plus and one normally connected to battery minus. This produces a voltage distribution across the semiconducting material in the unijunction, and the emitter is connected approximately to the $V/2$ location on the semiconductor (figure 13). No current flows between the emitter and the semiconducting material until the voltage of the emitter becomes greater than $V/2$, or half the battery voltage. When the emitter turns on, it effectively is connected to base 1 by the impedance of a forward diode. The impedance between base 2 and the emitter remains high, in the order of several thousand ohms.

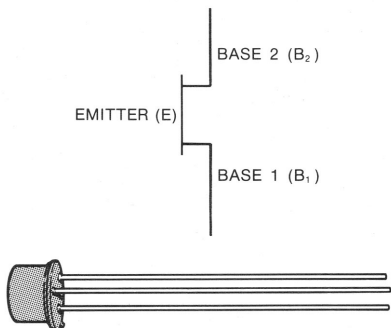

Figure 12. Unijunction transistor (UJT) symbol.

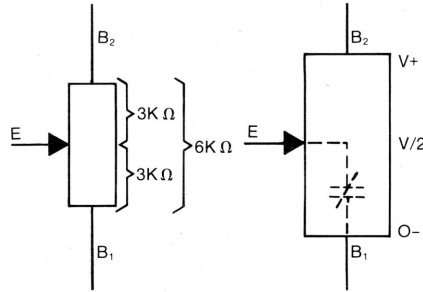

Figure 13. Unijunction transistor operation.

A **programmable unijunction transistor (PUT)** (figure 14) is similar in function to the unijunction transistor, except the trigger voltage level can be easily varied by the use of a simple potentiometer, allowing easy calibration of the RC time delay. No current flows between the anode and the cathode until the voltage at the anode is greater than voltage at the gate (figure 14).

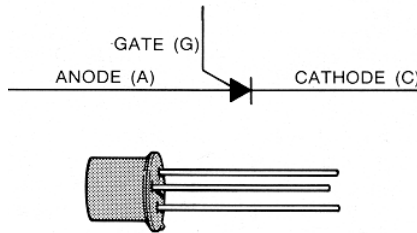

Figure 14. Programmable unijunction transistor (PUT) symbol.

A **silicon controlled rectifier (SCR)** is a rectifier with a gate to control conduction in the forward direction. The SCR shown in figure 15 is an open circuit between the anode and cathode until a gate signal is applied. With a proper gate signal, the SCR will conduct from the anode to the cathode until the anode current is removed.

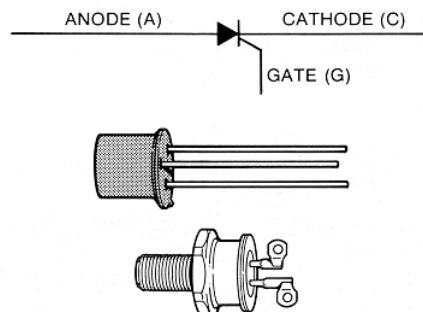

Figure 15. Silicon controlled rectifier (SCR) symbol.

ME Control Circuits

The **NPN transistor, in a simple circuit**, shows a battery voltage and a base signal in abbreviated form. The transistor is shown in a common emitter configuration in which the emitter completes both the base circuit and the collector circuit back to battery minus (figure 16).

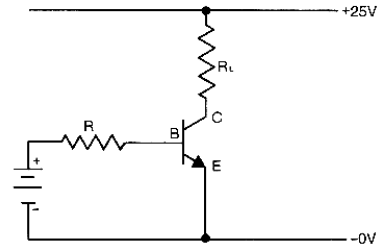

Figure 16. Simple NPN transistor circuit.

The voltages in a saturated transistor are noted in figure 17. It takes about 0.7 volt to forward bias the base emitter junction to produce a controlling base current. A transistor that is fully on or saturated will have about 0.3 volts or less from collector to emitter, with fairly low collector currents.

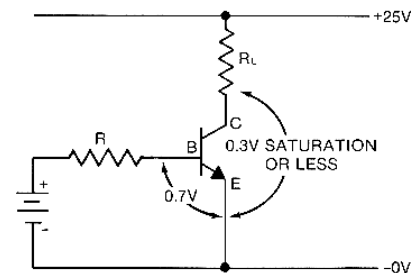

Figure 17. Saturated NPN transistor circuit.

Typical currents in a transistor circuit as shown in figure 18 are about 0.1 milliamps into the base which will produce about 5 milliamps in the collector, totalling about 5.1 milliamps in the emitter. Note that both the base and collector currents emit from the emitter. Thus, we see both the current gain and the power gain of a transistor in operation. The 0.1 milliamps in the base produces about fifty times the base current or 5 milliamps in the collector for a typical gain of 50. The power gain is even more outstanding.

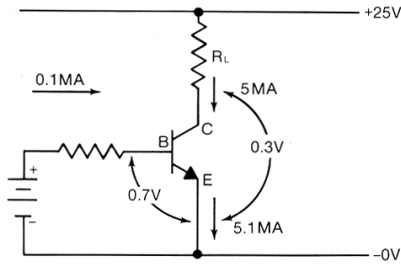

Figure 18.
Current and power gain in NPN transistor circuit.

Except that the PNP emitter emits current into the emitter, everything else said about the NPN transistor applies to the PNP transistor. Note this difference in that the input signal at the base for the PNP transistor is commonly referenced to battery plus (figure 19), where the base for the NPN is referenced to battery minus.

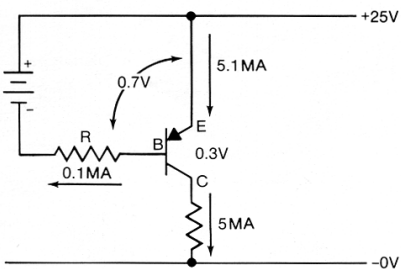

Figure 19.
PNP transistor circuit.

In circuits where collector currents or load currents of 5 milliamps are inadequate to power succeeding stages, such as gating high power SCR's or operating relay coils, transistors must be ganged together or connected in what is called a **Darlington circuit** (figure 20). Note that in this case the 0.1 milliamps entering transistor Q1 is amplified to 5.1 milliamps and is fed into the base of transistor Q2. The 5.1 milliamps into the Q2's base is amplified to about 255 milliamps in its collector, assuming each transistor has a gain of 50. The load circuit now has the

sum of the collector current in each transistor. Transistor Q2 will then have the capability of carrying up to about 250 mA (1/4 ampere).

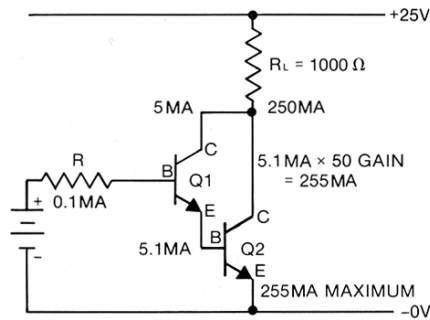

Figure 20.
Darlington pair circuit.

With a battery voltage of 25 Vdc, a transistor Q2 load, and a RL of 1000Ω (figure 20), the maximum Q2 collector current will be

$$I_{Q2} = \frac{ECC}{R_L} = \frac{25}{1000} = 25 \text{ mA.}$$

The collector current to Q2 has been limited by RL, resulting in Q2 saturating (or operating like an on-off switch).

Another circuit type as shown in figure 21 gives an added transistor feature. **The NPN transistor is in a common base configuration** where two separate power supplies of different polarities are powering the collector and the emitter. In this circuit the collector and the emitter both are carrying about the same current as they have in all previous cases. But, the emitter circuit is being driven by a 2-volt source and the collector circuit has a 25-volt source. The important feature of this circuit is the emitter and collector currents are essentially equal, and the collector voltage (if above one volt) has little or no effect on the collector currents.

This circuit is used in this case to transfer current from a low voltage circuit to a high voltage circuit. In the Type ME electronic control, the current from the ME control input bridge is transferred to the battery circuit with a common base transistor.

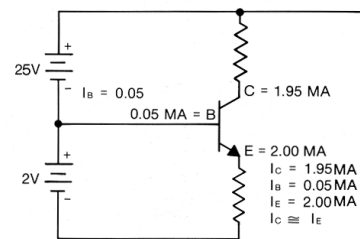

Figure 21.
Common base NPN transistor circuit with two power supplies.

The Type ME electronic control also uses the **bias circuit** shown in figure 22. In this circuit, two diodes produce about a -1.4 volt reference which is used to bias the timing plugs. Connected between the two diodes and the 6.8K resistor is a 17V ± 1% precision zener diode. This zener diode is used as a reference voltage for the minimum trip levels and time-current curves of the ME control. As used on the ME control tieboard, this point is called "-17 VOLTS" in that it is 17 Vdc less than the voltage at tieboard terminal 5B.

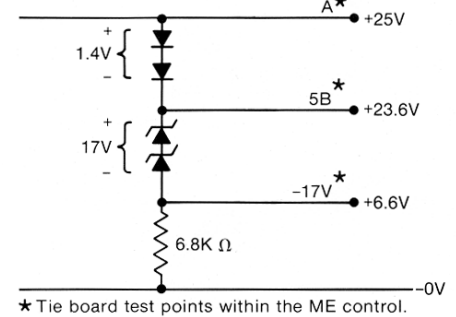

Figure 22.
Bias circuit.

The circuit used in the control reclosing and resetting functions has as its time delay a **conventional RC circuit** (figure 23). This circuit will reproduce an exact voltage charge characteristic on the capacitor each time the switch is closed. If the voltage charge in the capacitor can be very carefully measured, such as noting the exact time the voltage on the capacitor is equal to source voltage divided by 2, the circuit will accurately reproduce a constant timing interval.

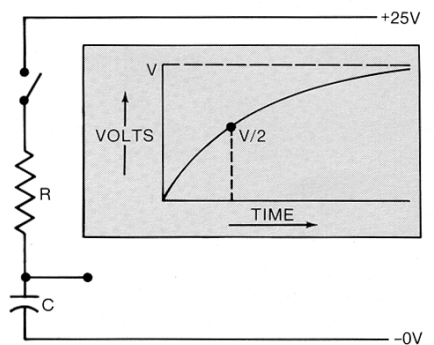

Figure 23.
Conventional RC circuit.

Figure 24 shows an **RC circuit operating with a unijunction transistor**. When the voltage on C becomes equal to V/2, the emitter turns on with very low impedance between the emitter and base 1, and C discharges through the

resistor connected to base 1—resulting in a small burst of current for a short duration of time. This current of short duration and low magnitude is insufficient to operate most relays, but it is of sufficient duration to operate static devices such as an SCR.

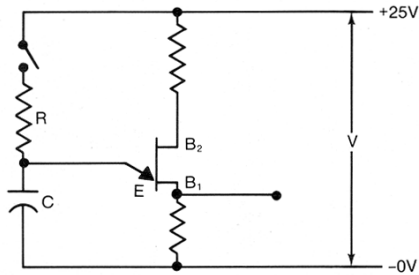

Figure 24.
RC circuit with unijunction transistor (UJT).

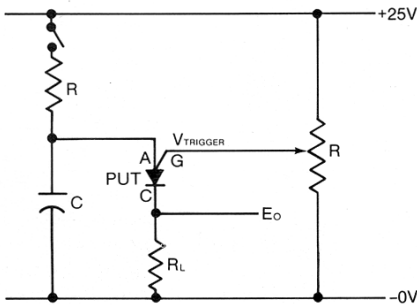

Figure 25.
RC circuit with programmable unijunction transistor (PUT).

Figure 25 illustrates the **programmable unijunction transistor (PUT) in an operational circuit**. Potentiometer R sets the trigger voltage ($V_{TRIGGER}$). As the voltage rises on Capacitor C, the PUT blocks current flow from capacitor C until the capacitor voltage exceeds trigger. The capacitor then discharges through the PUT and R_L , resulting in a brief voltage pulse at E_o .

The SCR (silicon controlled rectifier) is analogous to a self-latching relay (figure 26). Once turned on it remains on until turned off by an external event. A positive voltage pulse to the gate causes the SCR to turn on and remain on until the external turn off switch is opened to stop the current flow.

In a typical **SCR circuit** (figure 27), a time delay caused by the RC circuit and a voltage pulse from a unijunction are used to gate the SCR on.

The SCR will energize a coil, which can cause a mechanism such as a "Black Box" to operate and open the contact in the voltage circuit, turning off the SCR. Closing the switch will not turn on the SCR until the RC-UJT-SCR (figure 27) or RC-PUT-SCR (figure 28) operates a succeeding time.

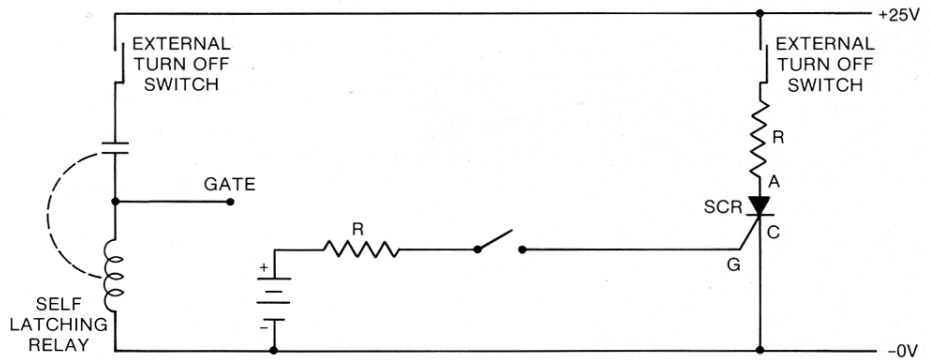

Figure 26.
Silicon controlled rectifier (SCR) circuit.

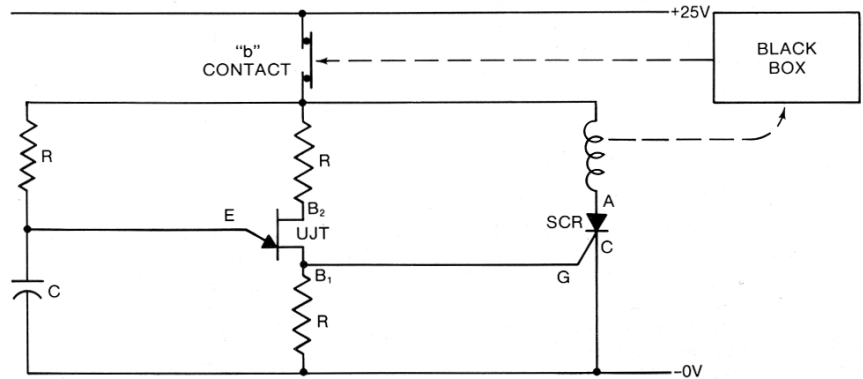

Figure 27.
RC circuit with UJT and SCR.

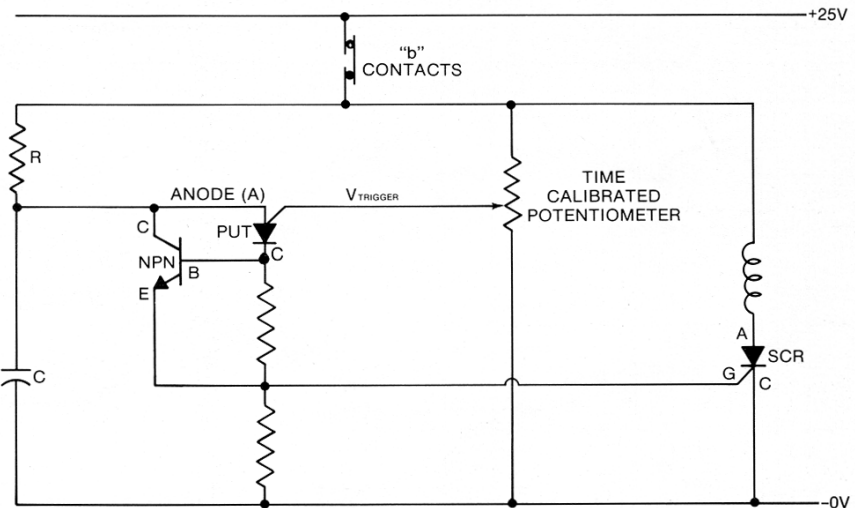
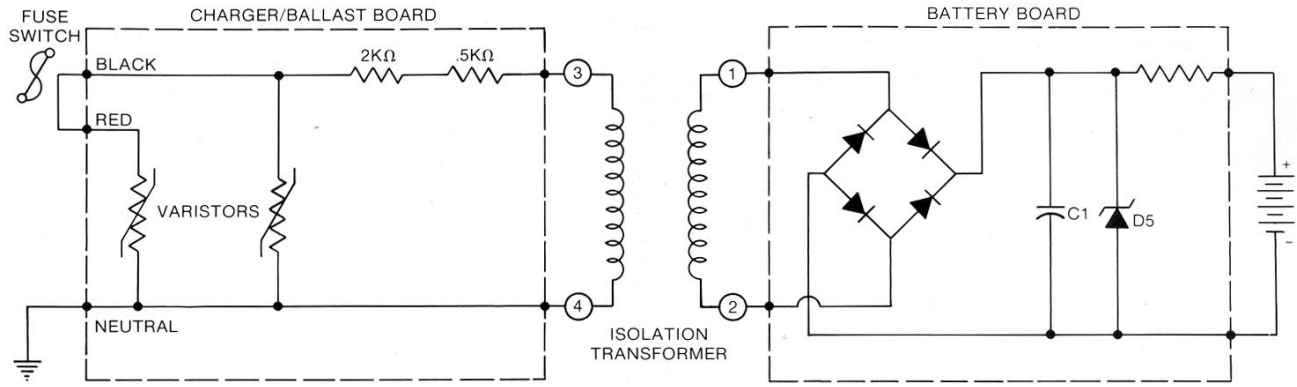

Figure 28.
RC circuit with PUT and SCR.

Figure 28 shows an RC circuit using the PUT and SCR. The trigger voltage of the PUT can be varied by the voltage set by the potentiometer. After closing the "b" contact, the voltage across capacitor C increases from zero at an exponential rate. When the capacitor

voltage exceeds the potentiometer voltage setting, the PUT triggers, gating the SCR. The function of the NPN transistor is to completely discharge capacitor C after a trigger operation of the PUT.



A. FORM 3A SURGE BOARD AND POTENTIAL CHARGER.

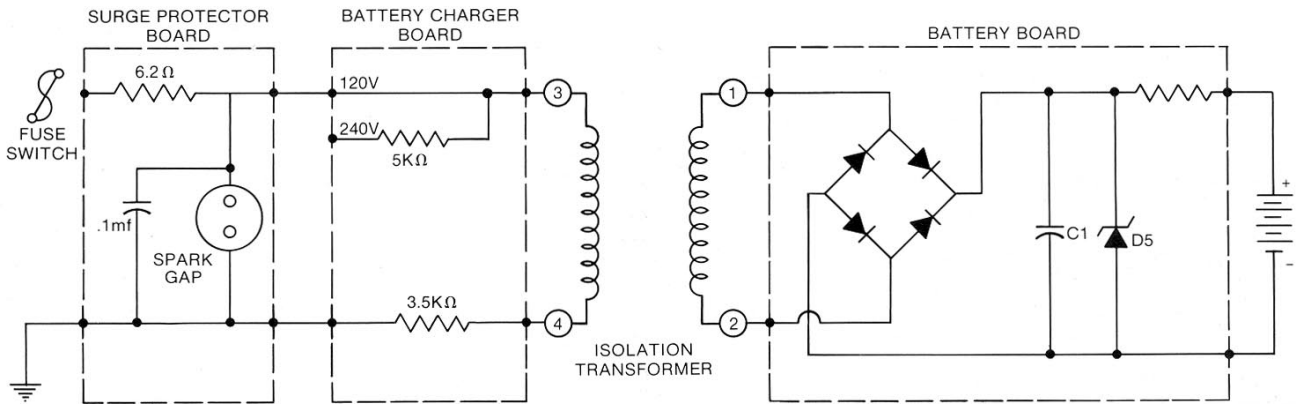

B. FORM 3 SURGE BOARD AND POTENTIAL CHARGER ACCESSORY.

Figure 29. Potential battery charger circuit.

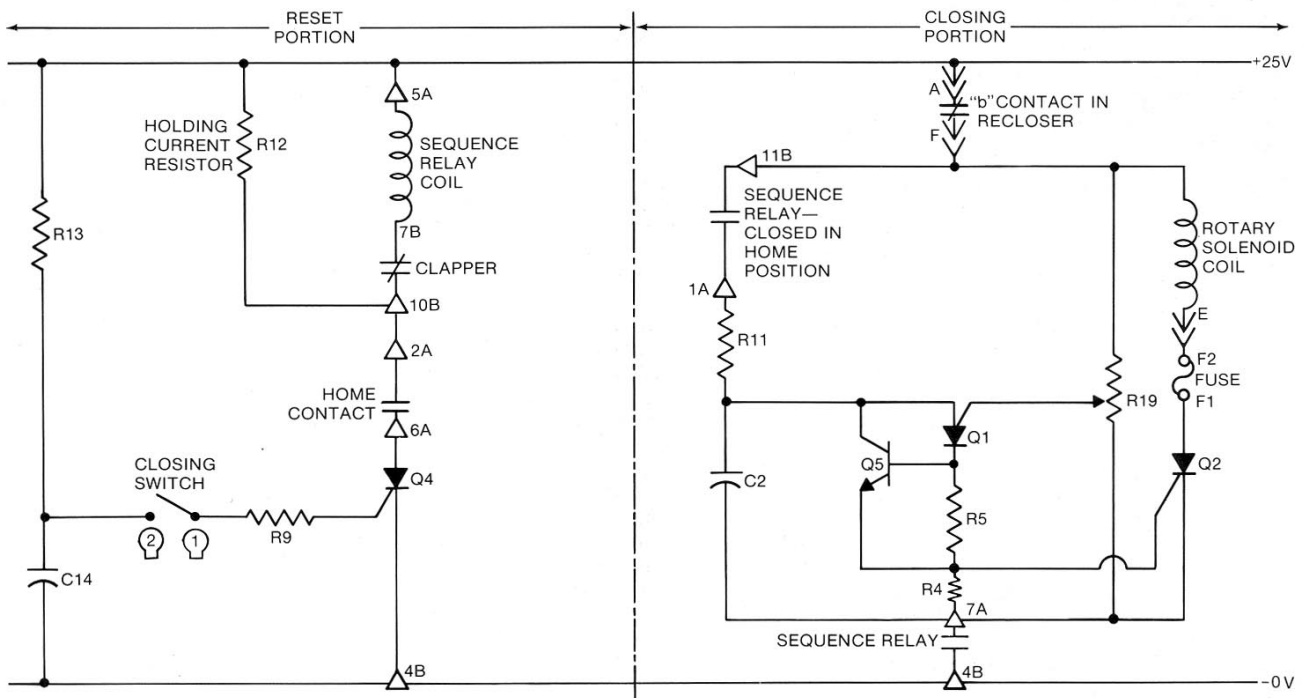

Figure 30. Closing from lockout circuit.

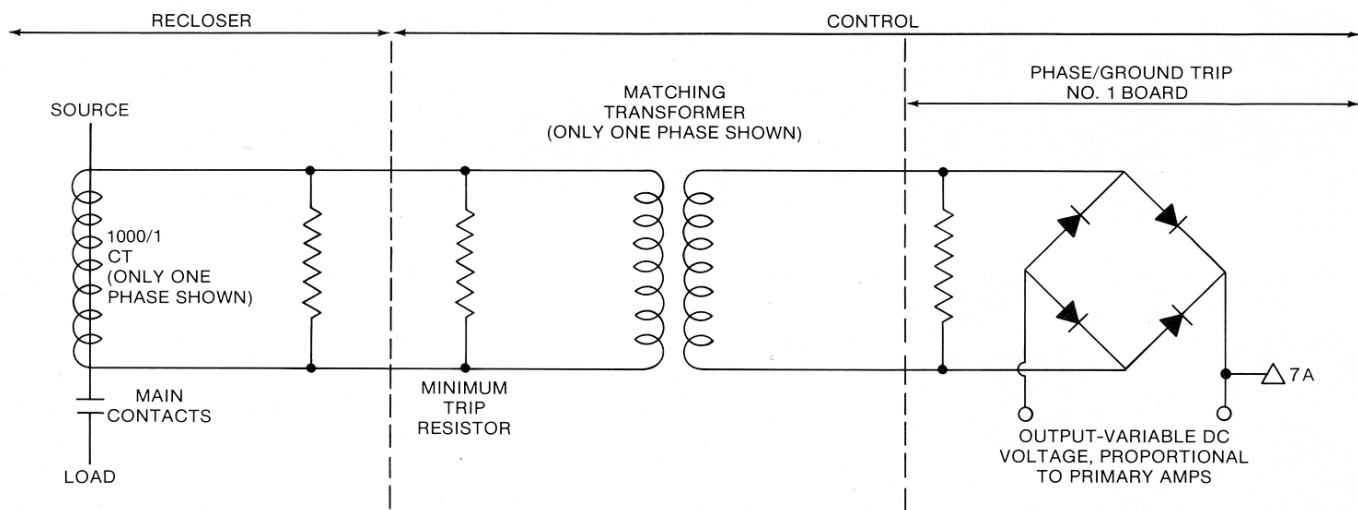

Figure 31.
Sensing circuit

CONTROL CIRCUITRY ANALYSIS

Potential Battery Charger

Shown in figures 29A and 29B are the schematics for the potential battery chargers for the Form 3 and Form 3A ME controls.

The AC input to the control battery charging circuit is applied through one or two current limiting resistors to the primary side of a 1:1 ratio isolating transformer. The AC output of the transformer is then applied to the input of a rectifier bridge and is converted to DC. This DC signal is filtered by capacitor C1 and is limited to 33 Vdc by zener diode D5. The proper charging rate to the control battery is set by the proper selection of resistance between the zener diode and the control battery.

Closing From Lockout Circuit

Following the circuitry of figure 30, whenever the control battery is plugged in, resistor R13 of the reclose-reset board charges capacitor C14 to battery voltage. If the control sequence relay is not in the home position, the home contact will be closed. Closing the manual control (PGS) switch will discharge the capacitor C14 through R9 into the gate to SCR Q4. This gates SCR Q4, which in turn energizes the sequence relay coil through the clapper contact, the home contact, and SCR Q4. The relay pulls in and the clapper opens the coil circuit, allowing the coil to advance the sequence relay wiper contacts to the next position. The holding current resistor R12 prevents SCR Q4 from switching off when the clapper contact opens. When the clapper contacts close again, the entire process repeats again at a very rapid rate.

This process continues until stopped by the home contact. The closing of

the recloser is initiated by closing the sequence relay open-at-lockout contact. The reclose operation has been described on page 5, figure 27 and 28, and will be described further on page 10, figure 35.

Sensing Circuit

As illustrated in figure 31, line current conditions are monitored continuously by a 1000:1 ratio sensing CT located on each phase of the recloser. A 100Ω shunting resistor is provided to protect the CT from damage if the control cable is disconnected while primary load currents exist.

The output current from the CT is applied to the ME control's matching transformer primary windings. The transformer steps up the voltage and isolates the signal from the DC control circuitry and from the other phases, which are not shown in figure 31. The bridge rectifier converts the transformer secondary voltage to full wave DC. This output Vdc level is proportional to the recloser load current and is used by the ME control to determine if fault currents exist, and if so—what magnitude they are for time current curve purposes.

By design of the ME control, the actual current input to the phase matching transformers at minimum trip is 100 milliamperes AC for phase and 5 milliamperes AC for ground. The minimum trip resistor diverts a portion of the CT output current, causing an increase in the ME control minimum trip level to any level desired by selection of the resistance of the minimum trip resistor.

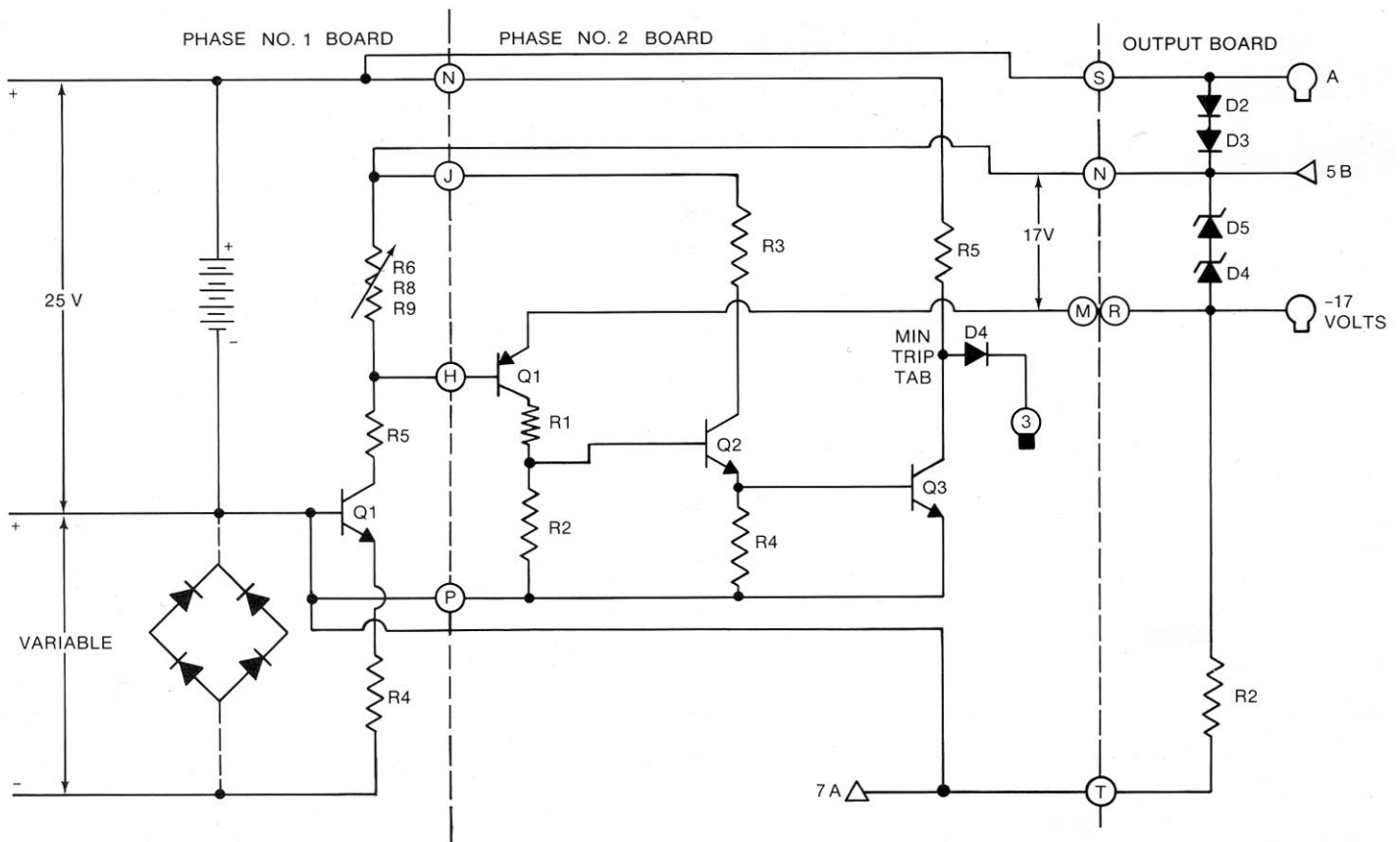

Figure 32.
Voltage level detector circuit.

Voltage Level Detection Circuit

An important part of the next several sections of the control (Phase-Trip No. 1 and No. 2 boards) as shown in figure 32 is the reference voltage set up on the output board and appearing at the terminal marked “-17 vo LTS” on the tieboard. The voltage is 17 volts ($\pm 1\%$) below voltage at terminal 5B. This reference voltage appears on the Phase No. 2 board, and provides a bias of minus 17 volts at the emitter of Q1 of the Phase Trip No. 2 board with respect to terminal 5B.

As illustrated in figures 31 and 32, the variable output voltage level is determined by the recloser load current. This variable voltage level is applied to the emitter-base junction of transistor Q1 and resistor R4 of the Phase Trip No. 1 board. Per figure 32, a nearly identical collector current will flow through precision resistors R6, R8, and R9. The voltage drop across these three resistors is therefore proportional to the recloser primary line current. (A simple version of this circuit can be seen in figure 21.)

Zener diodes D4 and D5 on the output board, along with transistor Q1 of the Phase Trip No. 2 board, functions as an electronic voltmeter which monitors the voltage across resistors R6, R8, and R9.

When the recloser’s primary load

current is sufficient in magnitude to cause 17.7 peak Vdc to appear across resistors R6, R8, and R9, transistor Q1 of the Phase Trip No. 2 board will be turned on. Transistor Q1 then turns on the Darlington transistor pair Q2 and Q3. Transistor Q3 is turned on and driven into saturation, lowering the voltage at the anode of D4 very close to zero. Thus, for any positive voltage on the cathode of D4, D4 is reversed biased and effectively an opened circuit.

Voltage Level Detector and Timing Circuit

Referencing figure 33, the emitter of Q4 (similar to the emitter of Q1 on the Phase Trip No. 1 board) connects to the negative side of the input bridges. The output voltage of the input bridge causes a current to flow through the base emitter of transistor Q4 and resistors R6 and R7. And, providing the collector voltage of Q4 is not zero, the collector current will be virtually equal to the emitter current. The collector current will then be virtually independent of the collector voltage and proportional to the recloser line current which produced the voltage across the output of the rectifier bridge.

At line currents below minimum trip, Q3 is turned off (no base current and no

collector emitter current); R5 (1000 Ω) then looks like a short circuit to transistor Q4. The normal or less than pickup current through D4 is less than 100 microamps, and since one side of R5 is connected to battery plus, the voltage at the cathode of D4 is also near battery plus.

At line currents above minimum trip, Q3 is saturated, back biasing D4 so it is effectively an open circuit. The collector current of Q4 is then supplied by the timing plug capacitors, causing the capacitors to charge under fault conditions. When the voltage at terminal 2 of the timing plug is charged to a voltage of about 7 Vdc (or 17.7 Vdc lower than tieboard terminal 5B), the emitter base of Q1 of the output board (figures 33 and 34) is forward biased, initiating operation of the output board.

If at any time during a timing operation, the line current drops below pickup level, Q3 switches off, and pin 3 of the timing plug is driven back to battery plus by resistor R5, resetting the capacitors in the timing plug.

NOTE: The selected timing plug can be disabled by removing battery plus from its pin 4 connection. Thus, by switching between two timing plugs, the control can switch from fast to slow time-current curves during a sequence to lockout under fault conditions.

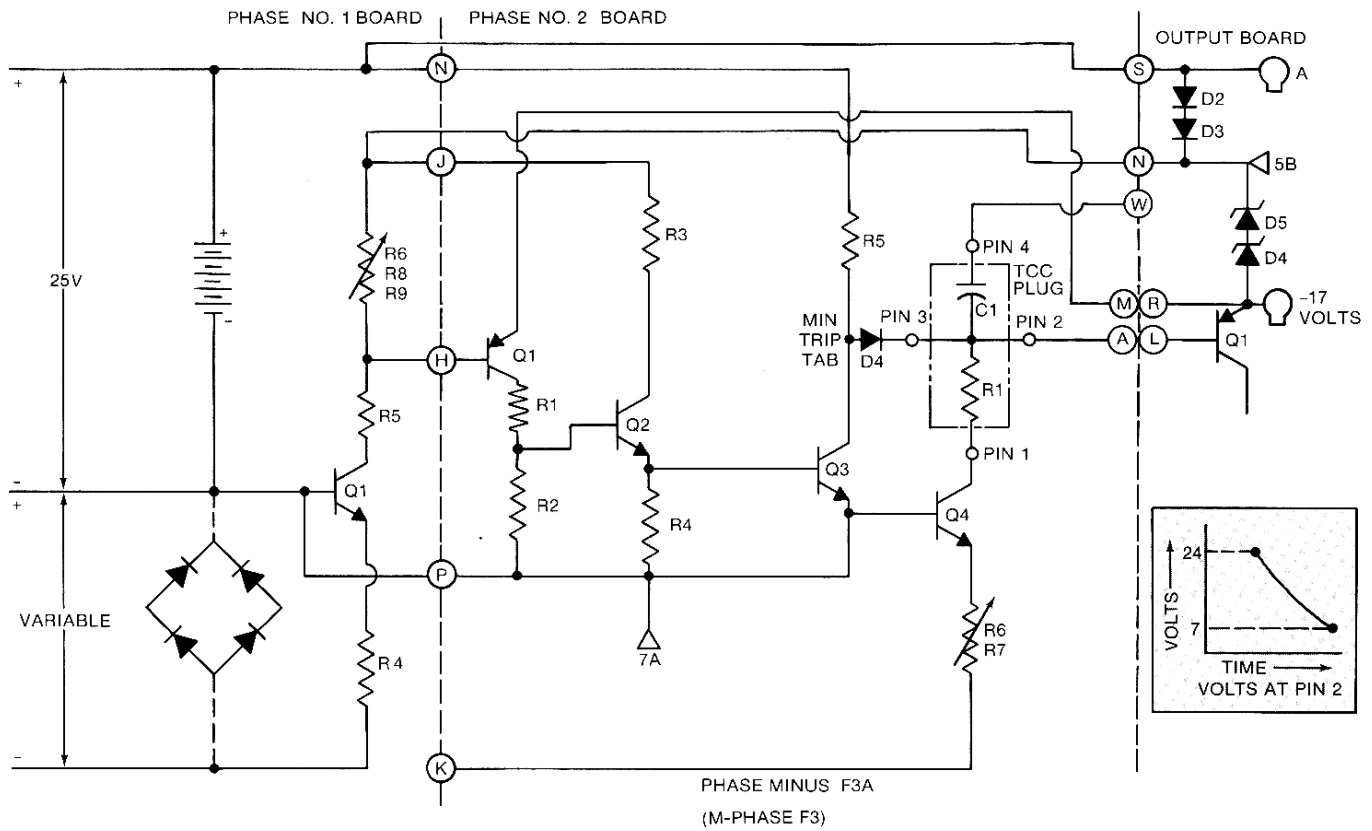

Figure 33.
Voltage level detector and timing circuit.

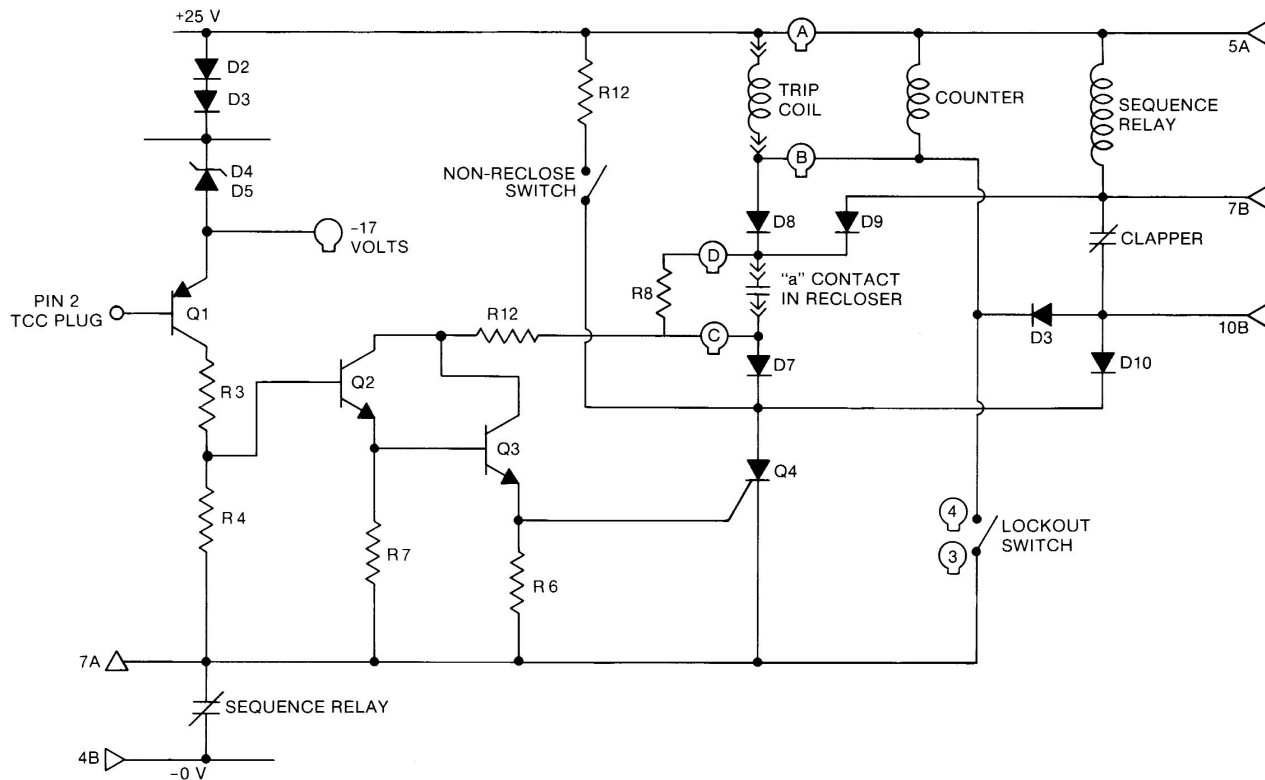

Figure 34.
Output board circuit.

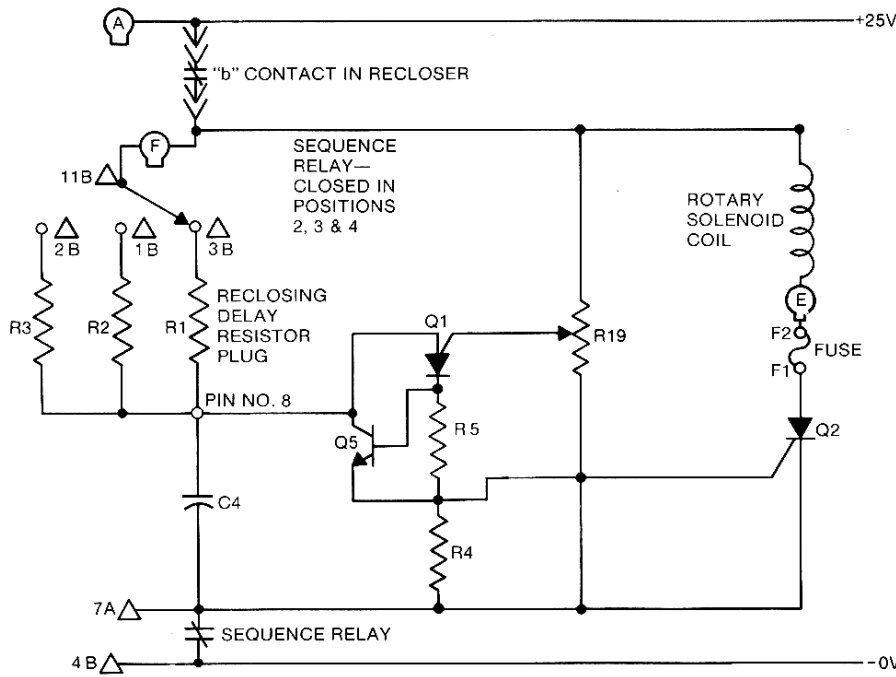

Figure 35.
Reclose board circuit

Output Board Circuits

When the timing plug causes Q1 of the output board (figure 34) to turn on, a trip operation will take place. Q1 drives the Darlington transistor amplifier pair Q2 and Q3 which in turn gates the trip SCR Q4. The collectors of Q2 and Q3 are supplied from the anode circuit of Q4. When Q4 turns on, its anode voltage switches to battery minus. With battery minus at this point, there is no positive voltage at the collectors of Q2 and Q3. This turns off Q2 and Q3, removing the gate signal from SCR Q4.

The trip SCR Q4 of the output board starts a trip operation when turned on. (The contacts shown between C and D in the Q4 anode circuit are in the recloser). Resistor R8 is a very high value, which will not allow the SCR to hold on after a trip operation.

While the trip SCR is on, the sequence relay coil, the counter, and the trip coil are energized. The “CD” contacts open when the recloser’s main contacts open. This causes the sequence relay, the counter, and the trip coil to be deenergized. The sequence relay contacts then advance on the de-energization of the relay coil.

In the event the “CD” contacts open before the sequence relay has pulled in far enough to advance its contacts on de-energization, a “7B-10B” contact bypass is provided. This circuit (5A, sequence relay coil, 7B clapper contacts, 10B, D10 and Q4 of the output board) bypasses the “CD” contacts and provides a separate

circuit to ensure proper operation of the sequence relay.

Reclose Board Circuit

After a trip operation, figure 35 shows the “b” contact (between control cable terminals A-F) in the recloser closed, starting a reclosing operation. With “b” closed, battery plus is applied to the sequence relay 11 B terminal. These wiper contacts select the proper reclosing delay plug (R1, R2, or R3). This resistor with C4 on the reclose reset board forms an RC timing circuit. When capacitor C4 charges to about 15 volts, the PUT Q1 breaks over, and the capacitor energy dumps through the PUT Q1 and transistor Q5, gating the SCR Q2. This causes the SCR to conduct, energizing the close coil through the fuse. When the recloser closes, the “b” contact opens — turning off the reclose circuits.

NOTE: In the event the recloser cannot close, the control fuse will blow in about 5 seconds. This removes the high current drain of the rotary solenoid, protecting the control battery. It also protects the closing coil in the recloser from damage if line voltage is too low to cause proper closure.

Reset Circuit

To cause reset of the control to the home position after clearing of temporary faults, a reset circuit is provided (see figure 36). The energy to operate the reset time-delay relay comes from terminal 5B of the sequence relay. When the wiper connected to 5B is in the second, third, or fourth position (8B, 4A, or 3A), then terminal Z of the diode board has battery plus to it providing positive bias to the reset PUT Q3.

Since battery power to the reset delay plug must come from the recloser “C-D” contact, automatic reset can only occur when the recloser is closed. The signal from the “C-D” contact causes the R-C timing circuit, consisting of the reset delay plug, and capacitors C7, C8 and C9, to trigger the reset PUT Q3. The PUT then gates the reset SCR Q4. The sequence relay is then energized by the sequence relay coil, the sequence relay clapper contact, diode D3, the sequence relay home contact, and the SCR Q4. The coil armature then pulls in, opening the clapper contact. The armature returns to normal, advancing the sequence relay wiper contacts, simultaneously reclosing the clapper contacts. Resistor R12 provides holding current to the SCR, and the cycle continues until the home contact shuts off power to the reset SCR Q4.

If a fault should occur during the reset time delay, the two diodes marked D3 and D4 discharge the reset timing capacitors through the minimum trip transistors Q3 of the phase and/or ground trip No. 2 boards. This circuitry then only allows automatic reset when the recloser is closed, and no fault exists on either phase or ground sensing of the control.

The above circuitry applies to the Form 3A control and any Form 2 or Form 3 control equipped with the KA304ME Reset After Successful Reclose Accessory.

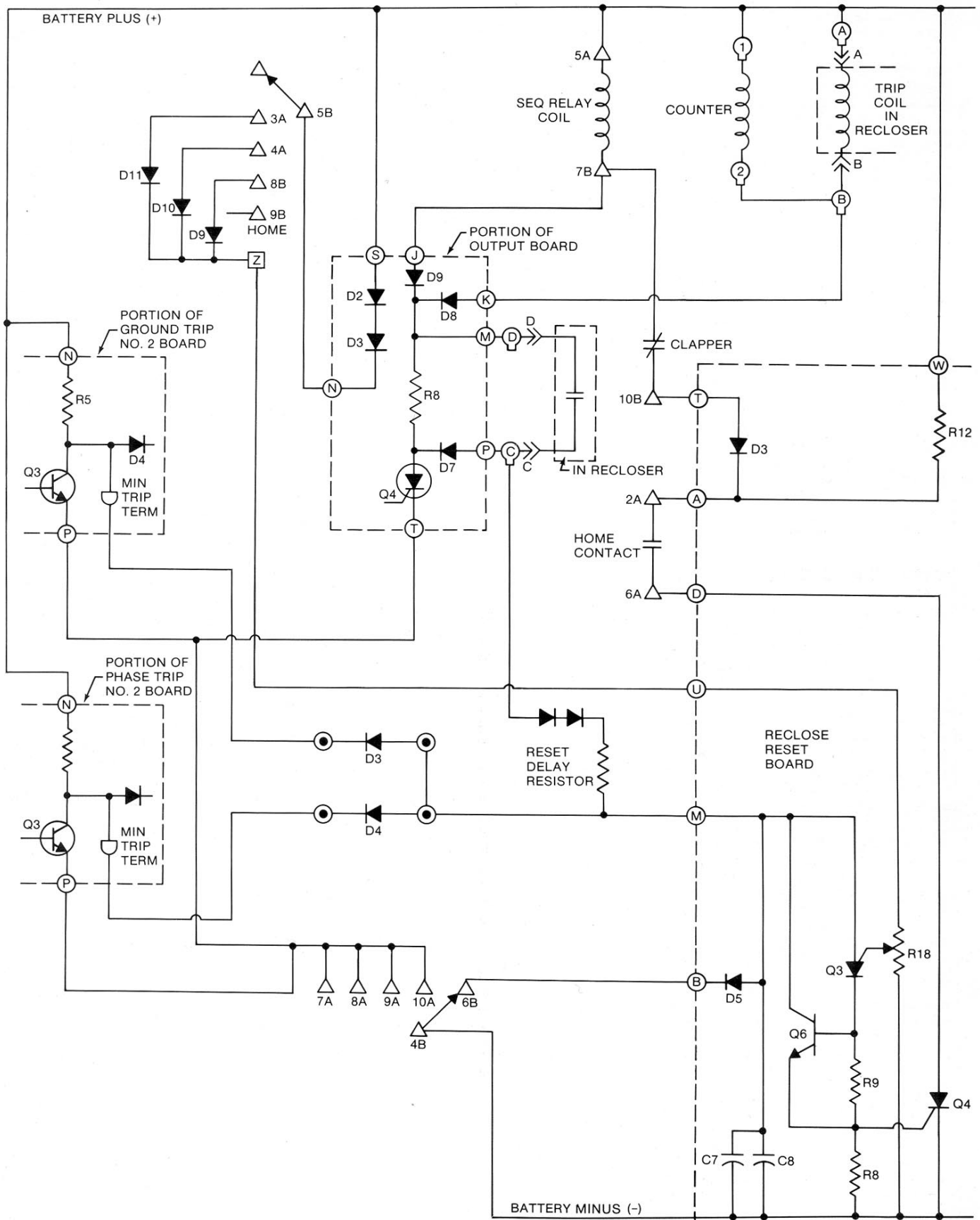

Figure 36.
Reset Circuit.



APPENDIX I

Figure 37a and 37b Schematic Diagram of Form 2..14, 15
Figure 38a and 38b Schematic Diagram of Form 3
and RE/WE Recloser16, 17
Figure 39a and 39b Schematic Diagram of form 3
and Motor Operated Recloser.....18, 19
Figure 40a and 40b Schematic Diagram of Form 3A
and RE/WE Recloser20, 21
Figure 41a and 41b Schematic Diagram of Form 3A
and Motor Operated Recloser.....22, 23

This manual S280-75-46 has three parts:

S280-75-46Apages 1-12

S280-75-46Bpages 13 - 19

S280-75-46Cpages 20 - 24

For the remaining pages of this manual (pages 13 - 19) refer to S280-75-46B, (pages 20 - 24) refer to S280-75-46C.