

Deadbreak Apparatus Connectors

600 A 15 and 25 kV Class BOL-T™ Terminator Installed on Tape Shield Cable Installation Instructions

S600-10-3
Service Information

Contents

General	1
Installation	2
Prepare the Cable	2
Install Tape Shield Adapter	4
Install BoL-T™ T-Body with Mating Parts ..	5
Splice Assembly Instructions	6

CAUTION: The Cooper Power Systems 600 A BOL-T terminator is designed to be operated in accordance with normal safe operating procedures. These instructions are not intended to supersede or replace existing safety and operating procedures. Terminators must be de-energized during operation or maintenance. Visible break and adequate grounding must be provided before cable work proceeds. Ensure that the terminator is rated for the intended application before it is installed.

BOL-T terminators should be installed and serviced only by personnel familiar with good safety practice and the handling of high-voltage electrical equipment.

CAUTION: Operational Capacitive Test Point Operating Instructions: Use only voltage indicating instruments specifically designed for test points. Use of conventional voltage sensing devices may provide false readings.

The test point must be dry and free of contaminants when taking voltage measurements. After measurements are taken: clean, dry, and lubricate the test point cap with silicone grease and assemble to the test point.

Fault Indicators: When using fault indicating devices on the test point, follow instructions provided with the indicator.

GENERAL

The Cooper Power Systems RTE® 600 A, 15 and 25 kV Class BOL-T deadbreak connectors are used to terminate high voltage underground cable on deadfront apparatus such as transformers, switches, and switchgear. They are fully shielded, submersible, and meet the requirements of ANSI/IEEE Standard 386—“Separable Insulated Connector Systems”.

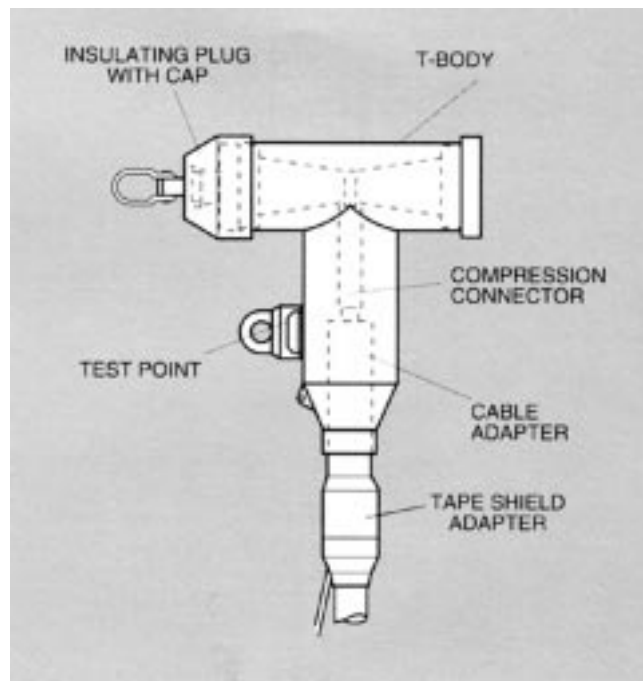

Figure 1.
Line illustration of 15 kV 600 A BOL-T terminator assembled on Tape Shield Cable.

EQUIPMENT REQUIRED

- BOL-T Connector Assembly Kit including:
 - T-Body
 - Cable Adapter
 - Insulating Plug with Cap
 - Compression Connector
 - Silicone Lubricant
 - Instruction Sheet
- Tape Shield Adapter
- Tools
 - Torque Wrench

These instructions do not claim to cover all details or variations in the equipment, procedure, or process described, nor to provide directions for meeting every contingency during installation, operation, or maintenance. When additional information is desired to satisfy a problem not covered sufficiently for the user's purpose, please contact your Cooper Power Systems sales engineer.

PREPARE THE CABLE

Step 1.

TRAIN CABLE.

- Position cable vertically so that it is centered between apparatus bushing and parking pocket, parallel to, and 7" (178 mm) from apparatus frontplate. (Refer to Figure 2.)
- Provide adequate cable slack for cable movement between standoff bushing and apparatus bushing.
- Support cable as needed to maintain position.
- Cut cable 1 3/4" (45 mm) from centerline of bushing. (Refer to Figure 2.)

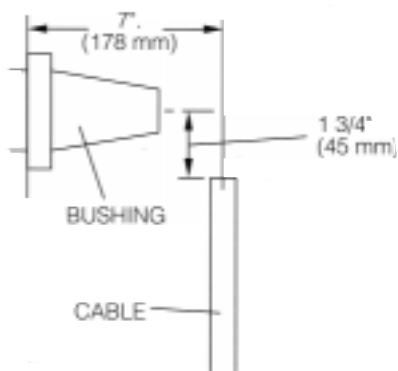

Figure 2.
Line illustration of cable training.

Step 2.

REMOVE OUTER JACKET.

- Find cable size in Table 1.
- **NOTE: Stripback length is dependent on cable size.**
- Dimension "J" is length of outer jacket to be removed for cable size. (Refer to Figure 3.) Remove outer jacket to length indicated in Table 1.
- **NOTE: Do not cut or damage metallic tape shield.**

Table 1
Stripback Dimensions

Conductor Size AWG (all types)	Outer Jacket Stripback Length "J"
#1, #2, 1/0, 2/0, 3/0, 410, 250, (300 compact) kcmil (300 concentric), 350, 400, 450, 500, 550, 600, 650, 700, 750, 800, 900, 1000 kcmil	13-1/2" (343 mm)
	14" (356 mm)

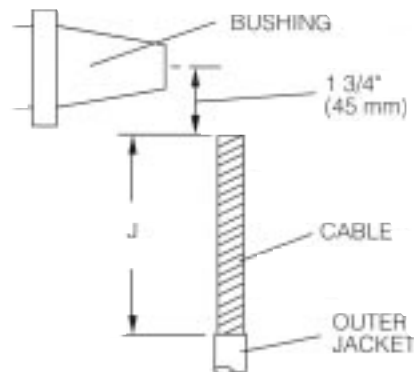

Figure 3.
Line illustration of removing outer jacket.

Step 3.

REMOVE TAPE SHIELD.

- Find cable size in Table 2.
- **NOTE: Stripback length is dependent on cable size.**
- Dimension "T" is length of tape shield to be removed for cable size. (Refer to Figure 4.)
- Slide hose clamp over cable and position it to length indicated in Table 2. (Refer to Figure 4.) Tighten the hose clamp in place.
- Remove tape shield layer to hose clamp 'T' dimension. (Refer to Figure 4.)
- **NOTE: Do not cut or damage the insulation shield.**

Table 1
Stripback Dimensions

Conductor Size AWG (all types)	Outer Jacket Stripback Length "T"
#1, #2, 1/0, 2/0, 3/0, 410, 250, (300 compact) kcmil (300 concentric), 350, 400, 450, 500, 550, 600, 650, 700, 750, 800, 900, 1000 kcmil	10-1/2" (267 mm)
	11" (279 mm)

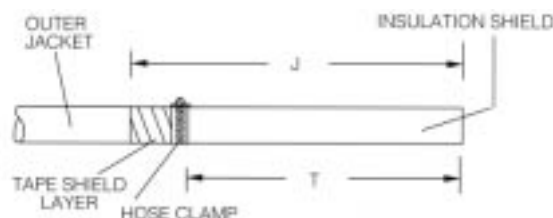

Figure 4.
Line illustration of removing tape shield layer.

- Carefully remove the hose clamp and wrap two turns of 3/4" (19 mm) vinyl plastic electrical tape over the end of the metallic tape to form a retainer. (Refer to Figure 5.)

**Step 4.
REMOVE INSULATION SHIELD.**

- Find cable size in Table 3.
NOTE: Stripback length is dependent on cable size.
- Dimension "L" is length of insulation shield to be removed for cable size. (Refer to Figure 5.)
- Remove insulation shield to length indicated in Table 3.
NOTE: Do not nick insulation.

**Table 3
Stripback Dimensions**

Conductor Size AWG (all types)	Outer Jacket Stripback Length "L"
#1, #2, 1/0, 2/0, 3/0, 410, 250, (300 compact) kcmil	10-1/4" (260 mm)
(300 concentric), 350, 400, 450 500, 550, 600, 650, 700, 750, 800, 900, 1000 kcmil	10-3/4" (273 mm)

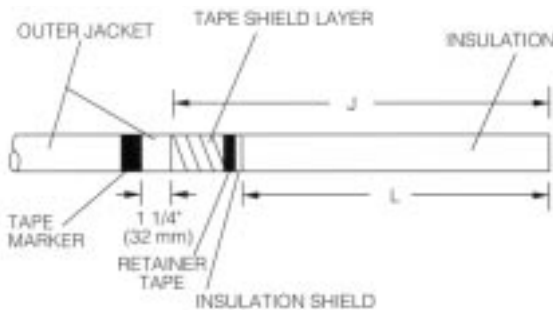

**Figure 5.
Line illustration of insulation shield stripback.**

**Step 5.
PUT TAPE MARKER IN PLACE.**

- Measure 1 1/4" (32 mm) from end of outer jacket. (Refer to Figure 5.)
- Wrap two turns of tape to serve as marker for tape shield adapter body location.

**Step 6.
REMOVE CONDUCTOR INSULATION.**

- **NOTE: Do not pencil cable.**
- Find cable size in Table 4.
- **NOTE: Stripback length is dependent on cable size.**
- Dimension "C" is length of insulation to be removed for cable size. (Refer to Figure 6.)
- Remove insulation exposing bare conductor to length specified in Table 4. (Refer to Figure 6.)
NOTE: Do not unwind conductor strands.

**Table 4
Bare Conductor Length**

Conductor Size AWG (all types)	Outer Jacket Stripback Length "C"
#1, #2, 1/0, 2/0, 3/0, 410, 250, (300 compact) kcmil	3-3/4" - 4-1/16" (95 - 103 mm)
(300 concentric), 350, 400, 450 500, 550, 600, 650, 700, 750, 800, 900, 1000 kcmil	4-3/8" - 4-11/16" (111 - 119 mm)

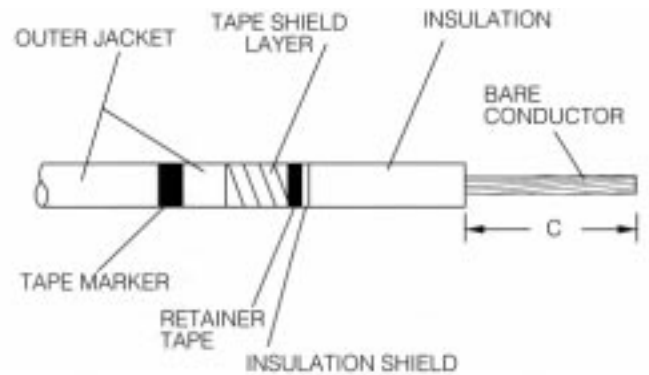

**Figure 6.
Line illustration of bare conductor length.**

**Step 7.
BEVEL INSULATION.**

- Remove sharp edge of insulation by beveling at 45° angle for approximately 1/4" (6 mm). (Refer to Figure 7.)

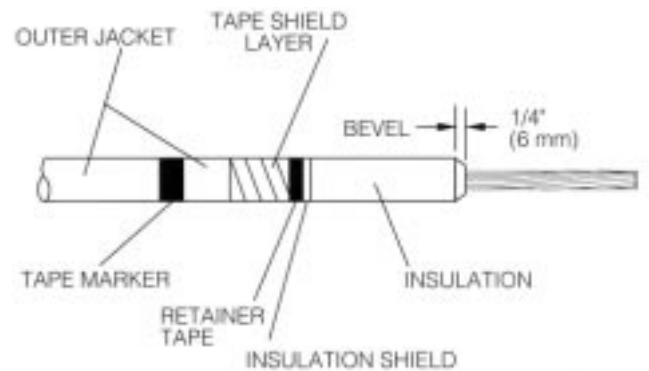

**Figure 7.
Line illustration of insulation bevel.**

**Step 8.
CLEAN INSULATION.**

- Clean insulation thoroughly with solvent dampened rag, wiping from conductor end toward insulation shield. (Refer to Figure 8.)
NOTE: Do not apply solvent directly to cable.
- Ensure that all traces of conductive residue are removed.

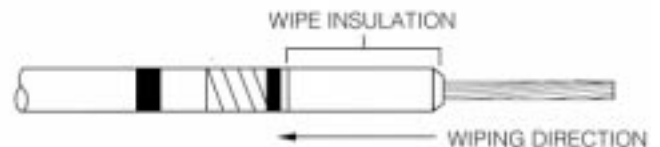

**Figure 8.
Line illustration of insulation cleaning.**

INSTALL TAPE SHIELD ADAPTER

Step 9.

INSTALL TAPE SHIELD ADAPTER BODY.

- Lubricate and prepare cable and the bore of the adapter body using silicone lubricant supplied or Cooper Power Systems' approved equivalent.
- Slide adapter body over cable, using a twisting motion in direction of the metallic tape shield wrap. Position adapter body against tape marker on outer jacket. (Refer to Figure 9.)

NOTE: Ground rod should be positioned to allow easy attachment of a ground wire.

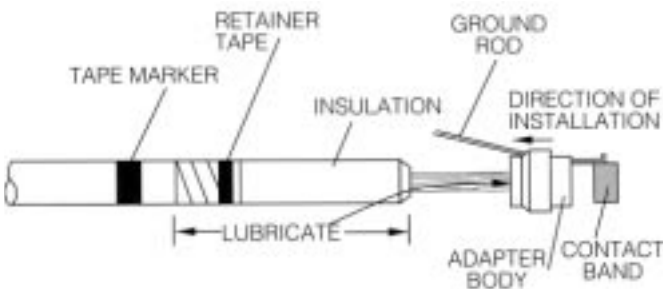

Figure 9.
Line illustration of adapter body.

Step 10.

ATTACH CONTACT BAND.

- Remove retainer tape from metallic tape shield. Wrap contact band around exposed metallic tape shield and install contact band retaining spring. Position spring around contact band and against end of grounding rod. (Refer to Figure 10.)

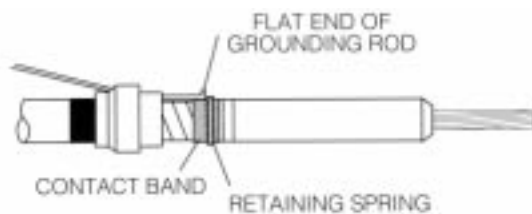

Figure 10.
Line illustration of installing contact band.

Step 11.

INSTALL ADAPTER CAP.

- Lubricate mating surface of adapter body and bore of adapter cap using silicone lubricant supplied, and slide adapter cap over cable. Seat cap firmly against sealing shoulder of body. (Refer to Figure 11.) Remove tape marker.

NOTE: After assembly, a small gap between the adapter body and cap is normal. (1/4 inch [6 mm] maximum.)

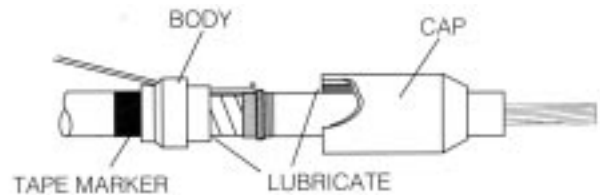

Figure 11.
Line illustration of installing adapter cap.

Step 12.

LUBRICATE AND INSTALL CABLE ADAPTER.

- Lubricate exposed cable insulation.
- Lubricate inside of cable adapter.
- Slide small end of cable adapter over cable (refer to Figure 12) using twisting motion until small end is flush with the shoulder of tape shield adapter. (Refer to Figure 13.)

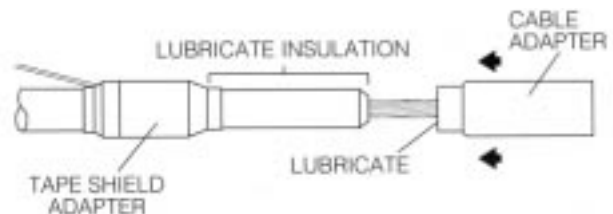

Figure 12.
Line illustration of installing adapter cap.

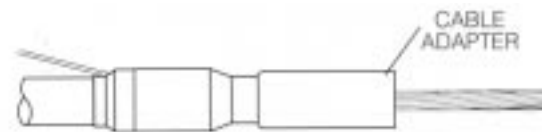

Figure 13.
Line illustration of installed adapter cap.

Step 13.

INSTALL COMPRESSION CONNECTOR.

- Wire brush conductor, only if it is aluminum.
- Remove protective cap from compression connector.
- Insert conductor completely into compression connector and rotate connector to distribute inhibitor.

NOTE: Connector must fully bottom on cable conductor.

- Align flats of compression connector and apparatus bushing for minimum conductor strain.
- Refer to crimp chart packaged with crimp connector for tool and die to be used.
- Make first crimp 1/2" (13 mm) below shoulder of compression connector. (Refer to Figure 14.)
- Rotate each successive crimp 90° on compression connector and allow 1/8" (3 mm) between crimps.
- Wipe excess inhibitor from connector and adapter surfaces.

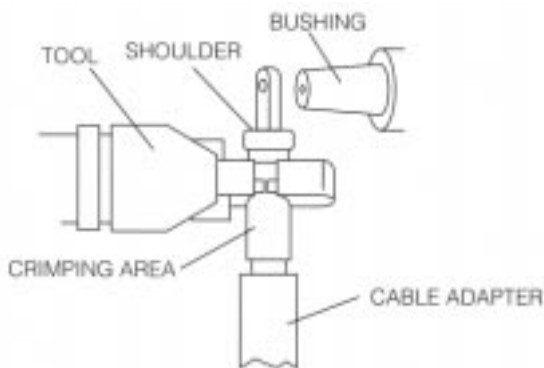

Figure 14.
Line illustration of crimping area.

Step 14. CHECK DIMENSIONS.

- Check length from end of compression connector to top of cable adapter. Length should be between 6-1/4" and 7-1/4" (159 - 184 mm). (Refer to Figure 15.)

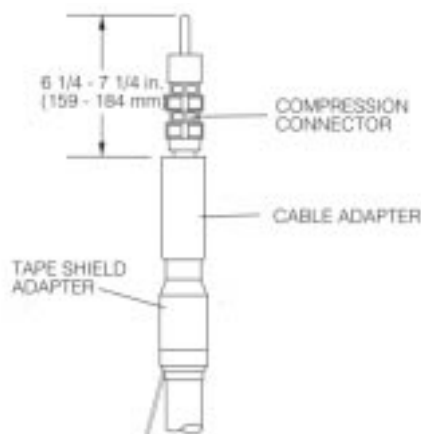

Figure 15.
Line illustration for dimensional check.

INSTALL BOL-T T-BODY WITH MATING PARTS

Step 15. INSTALL T-BODY.

- Clean and then lubricate outside of cable adapter with lubricant supplied.
- Clean and then lubricate inside of T-Body with lubricant supplied.
- Slide T-Body onto cable until compression connector eye is centered in 600 A interfaces. (Refer to Figure 16.)

NOTE: If test point T-Body is used, ensure test point is opposite the frontplate side of T-Body.

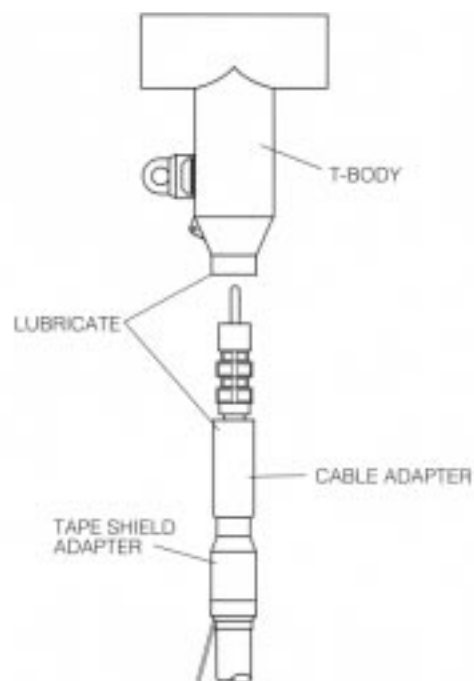

Figure 16.
Line illustration of T-Body installation.

Step 16. INSTALL BOL-T CONNECTOR ONTO APPARATUS BUSHING.

- Clean and lubricate mating interfaces of T-Body and apparatus bushing with lubricant supplied. (Refer to Figure 17.)
- Place T-Body on apparatus bushing and align hole in compression connector with hole or stud on bushing.

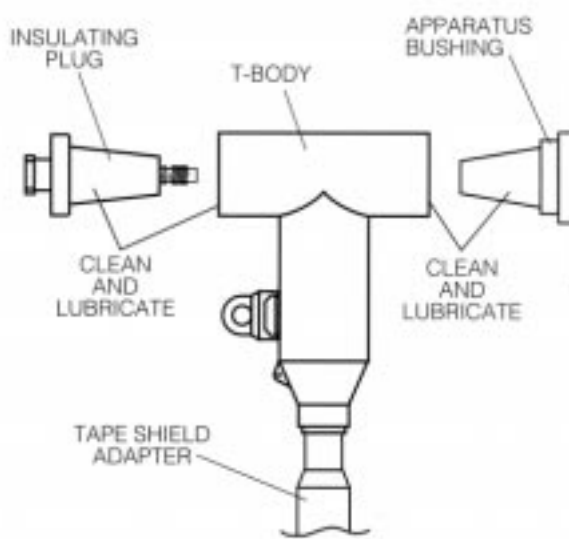

Figure 17.
Line illustration of insulating plug installation.

- Clean and lubricate interface of mating part (i.e., insulating plug, reducing well plug or deadbreak tap plug).
 - While pushing T-Body onto bushing, insert mating parts into T-Body and turn by hand to engage threads.
 - Tighten insulating plug with a 1N socket and torque to 55 ft-lb (Refer to Figure 18.)
- NOTE: Seating is correct when dimension “A” is achieved. If a reducing well plug or deadbreak tap plug is used instead, they must be tightened to 55 ft-lb using a spanner wrench.**

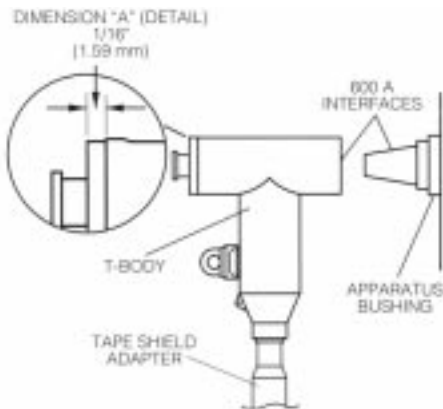

Figure 18.
Line illustration of BOL-T Connector installation onto Apparatus Bushing.

Step 17.

CAP THE INSULATING PLUG.

- Clean and lubricate inner surface of insulating plug cap with lubricant supplied. (Refer to Figure 19.)
 - Attach shotgun stick onto cap ring.
 - Push cap onto insulating plug until it snaps into place.
- NOTE: A reducing well plug or deadbreak tap plug requires an insulated mating apparatus on the 200 A interface. To cap the 200 A interface, follow instructions supplied with apparatus used.**

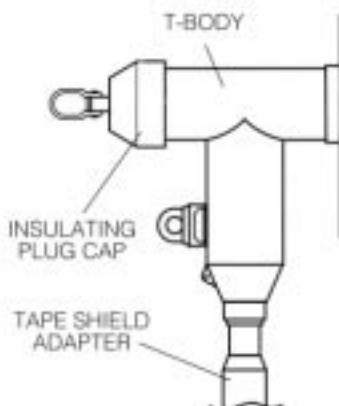

Figure 19.
Line illustration of installing the insulating plug cap.

Step 18.

GROUND SYSTEM.

- Connect tie-off tab of T-Body with at least one strand of drain wire to cable concentric neutral wires or to common ground point. (Refer to Figure 20.)
 - Connect ground lead to tape shield adapter ground-rod and then to system ground.
- NOTE: The tape shield ground is #4 solid copper. The connection to system ground should be at least equivalent to the size of this rod.**

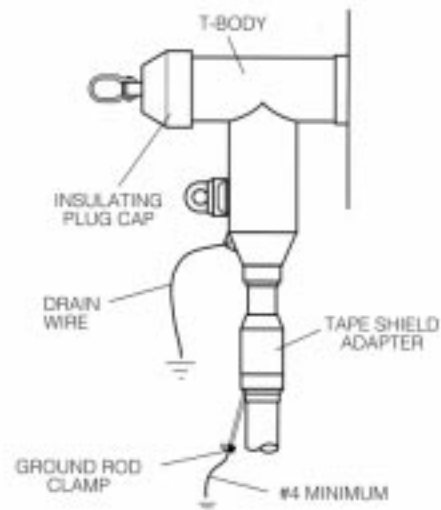

Figure 20.
Line illustration of grounding.

SPLICE ASSEMBLY INSTRUCTIONS

- To assemble a splice, prepare all cables following Steps 1 through 15.
- Clean and lubricate mating interfaces of all T-Bodies and mating parts (i.e., insulating plugs and connecting plugs).
- Begin by inserting an insulating plug into a T-Body, lining up hole in compression connector with stud on plug. (Refer to Figure 21.)

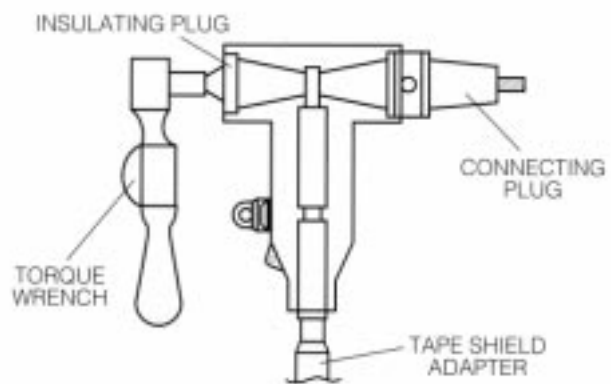

Figure 21.
Line illustration of protective cap installation.

- Insert a connecting plug into open interface of T-Body and thread onto insulating plug.
- Secure connecting plug using T-wrench. Use torque wrench to tighten insulating plug to 55 ft-lb of torque.
- Insert interface of connecting plug into interface in second T-Body. Be sure to line up hole in compression connector with stud on plug.
- To assemble a 3- or 4-way splice, repeat the steps described above for installing additional connecting plugs and T-Bodies.
- To complete the splice, insert second insulating plug into open end interface on end T-Body and thread onto connecting plug. Secure connecting plug with T-wrench and use torque wrench to tighten second insulating plug to 55 ft-lb of torque. (Refer to Figure 22.)
- Clean and lubricate inner surface of two insulating plug caps with lubricant supplied.
- Push caps onto insulating plugs until they snap into place.
- Connect tie-off tabs of T-Bodies with at least one strand of drain wire (#4 minimum) to common ground point.
- Connect ground lead to tape shield adapter grounding rod and then to system ground.

NOTE: The tape shield ground rod is #4 solid copper. The connection to system ground should be at least equivalent to the size of this rod.

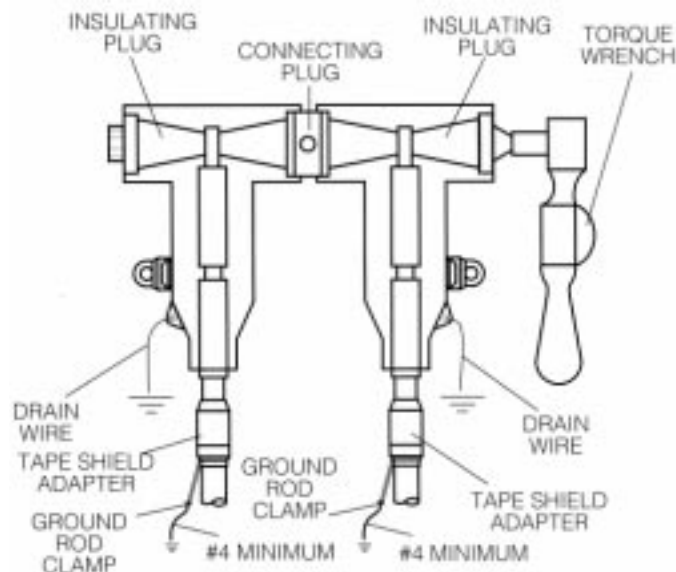

Figure 22.
Line illustration of two BOL-T assemblies.

©1997 Cooper Power Systems, Inc.
RTE® is a registered trademark of Cooper Industries, Inc.
BOL-T™ is a trademark of Cooper Industries, Inc.
#5000050741 Rev. 1

 **COOPER** Power Systems

P.O. Box 1640, Waukesha, WI 53187
www.cooperpower.com