

Loadbreak Apparatus Connectors

200 A 35 kV Class Loadbreak Elbow Retrofit Instructions from Single-Phase Solid Probe and Three-Phase Probe to Single-Phase QuickMake Probe and Tan Cuff

Service Information
S500-41-3

Contents

| | |
|---------------------------------|---|
| Product Information | 1 |
| Safety Information | 2 |
| Installation Instructions | 3 |

WARNING:

All associated apparatus must be de-energized during any hands on installation or maintenance.

CAUTION:

This elbow should only be installed and serviced by personnel familiar with good safety practices and the handling of high-voltage electrical equipment. These instructions are not intended to supersede or replace existing safety and operating procedures. Where applicable, the requirements of national and/or local codes and insurance underwriters must be fulfilled.

CAUTION:

Since a cable that has been energized can hold a charge for some time even after it has been de-energized, care is required when working with any device that is connected to a cable which had been energized recently. The use of rubber gloves and other protective equipment is strongly recommended. Failure to comply may result in death, severe personal injury and equipment damage.

PRODUCT INFORMATION

Introduction

The Cooper Power Systems Loadbreak Elbow connector is a fully-shielded and insulated plug-in termination for connecting underground cable to transformers, switching cabinets and junctions equipped with loadbreak bushings. The elbow connector and bushing insert comprise the essential components of all loadbreak connections.

Read This Manual First

Read and understand the contents of this manual and follow all locally approved procedures and safety practices before installing or operating this equipment.

Additional Information

These instructions cannot cover all details or variations in the equipment, procedures, or process described nor provide directions for meeting every possible contingency during installation, operation, or maintenance. For additional information, contact your representative.

Acceptance and Initial Inspection

Each elbow is in good condition when accepted by the carrier for shipment. Upon receipt, inspect the shipping container for signs of damage. Unpack the elbow and inspect it thoroughly for damage incurred during shipment. If damage is discovered, file a claim with the carrier immediately.

Handling and Storage

Be careful during handling and storage of the elbow to minimize the possibility of damage. If the elbow is to be stored for any length of time prior to installation, provide a clean, dry storage area.

Standards

ISO 9001:2008 Certified Quality Management System

CAUTION:

Single-phase QuickMake (21.1/36.6 kV) elbows should only be mated with single-phase (21.1/36.6 kV) Tan nose piece products. Failure to comply may result in death, severe personal injury and equipment damage.



SAFETY FOR LIFE



Cooper Power Systems products meet or exceed all applicable industry standards relating to product safety. We actively promote safe practices in the use and maintenance of our products through our service literature, instructional training programs, and the continuous efforts of all Cooper Power Systems employees involved in product design, manufacture, marketing and service.

We strongly urge that you always follow all locally approved safety procedures and safety instructions when working around high-voltage lines and equipment and support our “Safety For Life” mission.

SAFETY INFORMATION

The instructions in this manual are not intended as a substitute for proper training or adequate experience in the safe operation of the equipment described. Only competent technicians, who are familiar with this equipment should install, operate and service it.

A competent technician has these qualifications:

- *Is thoroughly familiar with these instructions.*
- *Is trained in industry-accepted high- and low-voltage safe operating practices and procedures.*
- *Is trained and authorized to energize, de-energize, clear, and ground power distribution equipment.*
- *Is trained in the care and use of protective equipment such as flash clothing, safety glasses, face shield, hard hat, rubber gloves, hotstick, etc.*

Following is important safety information. For safe installation and operation of this equipment, be sure to read and understand all cautions and warnings.

Hazard Statement Definitions

This manual may contain four types of hazard statements:

DANGER:

Indicates a hazardous situation which, if not avoided, will result in death or serious injury.

WARNING:

Indicates a hazardous situation which, if not avoided, could result in death or serious injury.

CAUTION:

Indicates a hazardous situation which, if not avoided, could result in minor or moderate injury.

CAUTION: Indicates a hazardous situation which, if not avoided, could result in equipment damage only.

Safety Instructions

Following are general caution and warning statements that apply to this equipment. Additional statements, related to specific tasks and procedures, are located throughout the manual.

DANGER:

Hazardous voltage. Contact with high voltage will cause death or severe personal injury. Follow all locally approved safety procedures when working around high- and low-voltage lines and equipment.

WARNING:

Before installing, operating, maintaining, or testing this equipment, carefully read and understand the contents of this manual. Improper operation, handling or maintenance can result in death, severe personal injury, and equipment damage.

WARNING:

This equipment is not intended to protect human life. Follow all locally approved procedures and safety practices when installing or operating this equipment. Failure to comply may result in death, severe personal injury and equipment damage.

WARNING:

Power distribution and transmission equipment must be properly selected for the intended application. It must be installed and serviced by competent personnel who have been trained and understand proper safety procedures. These instructions are written for such personnel and are not a substitute for adequate training and experience in safety procedures. Failure to properly select, install or maintain power distribution and transmission equipment can result in death, severe personal injury, and equipment damage.

INSTALLATION INSTRUCTIONS

Complete elbow kit includes:

- Single-phase (21.1/36.6 kV) QuickMake Probe with Wrench
- Tan Cuff
- Single-phase Loadbreak “White” Identification Band
- Wrench
- Silicone Lubricant

Step 1

OLD PROBE REMOVAL

- Using one of the loose wrench provided, remove “old” probe from the elbow and discard.

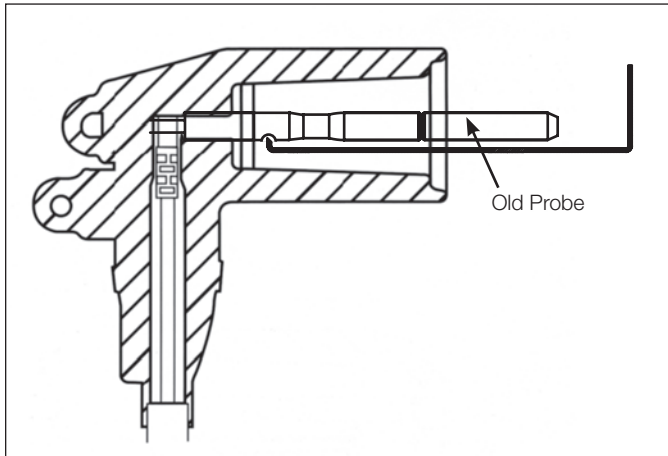

Figure 1.
Remove old probe.

Step 2

QUICKMAKE PROBE INSTALLATION

NOTE: Do not remove the wrench from the new probe.

- Clean and regrease 200 A elbow and bushing interfaces with silicone lubricant provided.
- Thread the “new” probe into the elbow and tighten it until the wrench bends 90°. See Figure 2.
- Remove the O-Ring from around the wrench.
- The wrench can then be removed by pulling on the arc follower to relieve spring pressure.

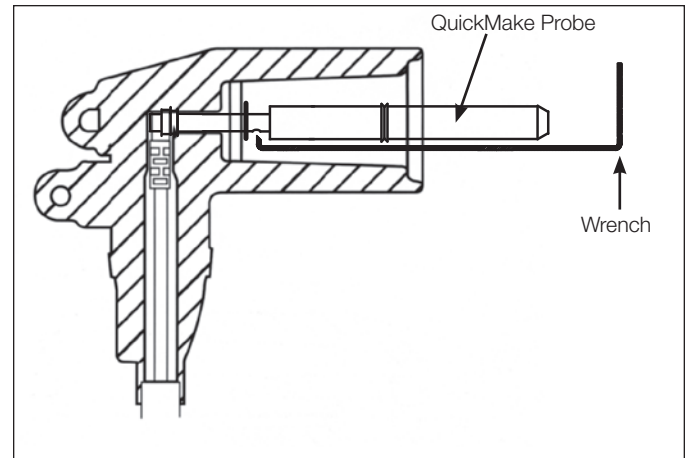

Figure 2.
Installation of QuickMake probe.

- Place “tan” cuff over existing “purple” cuff as shown in Figure 3.
- Remove white/black/white three-phase loadbreak identification band and discard. Replace with “white” single-phase identification band (stretch over elbow).

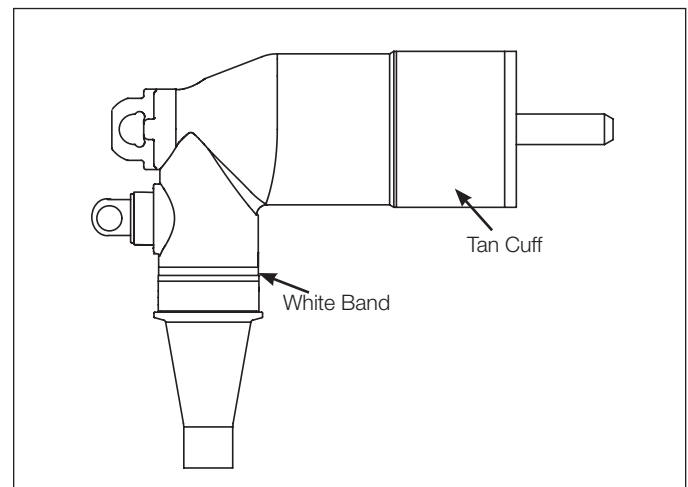

Figure 3.
Retrofit complete with tan cuff and white identification band.

