

Magnum DS metal-enclosed low-voltage switchgear



Contents

Description	Page
Ratings	
Standards	2
Certifications	2
Voltage transformers	13
Control power transformers	13
Application	
Standards	13
System voltage/frequency	13
Continuous current ratings	13
Ambient temperature	13
Altitude	13
Unusual environments and operating conditions	14
Types of systems	14
System application	15
Transformer main secondary breakers	16
Bus sectionalizing (tie) breakers	16
Automatic transfer schemes and intelligent control	16
Generator breakers	16
Feeder breakers—general	17
Motor starting feeder breakers	17
Group motor feeder breakers	17
Ground fault	18
Sequence of operation	21
Features	
Structure	33
Bus	34
Wiring	34
Instrumentation/metering	35
Instrumentation—door mounted	36
Accessories and options	36
Breaker	36
Typical specification	39



Powering Business Worldwide

Why Magnum DS switchgear?

Eaton's Magnum DS® power circuit breaker switchgear is backed by 40 years of power circuit breaker and switchgear development that have set the industry standards for quality, reliability, maintainability, and extended operating life, when it comes to protecting and monitoring low-voltage electrical distribution systems. Magnum DS switchgear is designed to meet the changing needs of our customers by providing:

- Lower maintenance costs
- Higher interrupting ratings
- Better coordination capability
- Increased tripping sensitivity
- Better metering accuracy
- Higher quality and reliability
- State-of-the-art monitoring and communications

Magnum DS switchgear can meet the needs for general applications, service entrance, harsh environments, multiple source transfer, special grounding systems and many others.

Modern designed Magnum DS metal-enclosed low-voltage switchgear and power circuit breakers provide:

- 100% rated, fully selective protection
- Integral microprocessor-based breaker tripping systems
- Two-step stored-energy breaker closing
- 100 kA short-circuit bus bracing standard
- Optional 150 kA and 200 kA short-circuit bus bracing, without preceding current limiting fuses

Many other features for coordinated, safe, convenient, trouble-free, and economical control and protection of low-voltage distribution systems are also provided.

Magnum DS switchgear conforms to the following standards: NEMA® SG3 and SG5, CSA®, ANSI C37.20.1, C37.51, and UL® Standard 1558 and is built in an ISO® certified facility.

Maximum ratings for Magnum DS switchgear are 600 Vac, 6000 A continuous cross bus and 200,000 A short-circuit capacity.

Ratings

Table 1. Voltage ratings (Vac)

System voltage	Maximum voltage
208/240	254
480	508
600	635

Table 2. Available bus ratings

Cross bus ampacity	Vertical bus ampacity	Bus bracing
2000	2000	100 kA, 150 kA, 200 kA
3200	3200	100 kA, 150 kA, 200 kA
4000	4000	100 kA, 150 kA, 200 kA
5000	5000	100 kA, 150 kA, 200 kA
6000	—	100 kA, 150 kA, 200 kA
8000	—	100 kA, 150 kA, 200 kA
10,000	—	100 kA, 150 kA, 200 kA

Note: In addition to the available bus bracings shown above, the bus has been tested for short-circuit values of 85,000 A for a full 60 cycles.

Standards and certifications

Standards

Magnum DS switchgear conforms to the following standards: NEMA SG3 and SG5, CSA, ANSI C37.20.1, C37.51, and UL Standard 1558.

Certifications

Magnum DS switchgear assemblies have undergone an extensive seismic qualification program. The test program utilized ANSI standard C37.81, the Uniform Building Code® (UBC) and the California Building Code (CBC) as a basis for the test program. The assemblies have been tested and qualified to exceed these requirements.

American Bureau of Shipping (ABS) certification is available for those instances where it is required.

Table 3. Magnum DS switchgear Class UL 1066 low-voltage power circuit breakers—ANSI

Frame amperes	Breaker type	Frame type	rms Symmetrical current ratings kA 50/60 Hz ①				
			Interrupting at 254 Vac	Interrupting at 508 Vac	Interrupting at 635 Vac	Short-time withstand rating at 254/508 Vac	Short-time withstand rating at 635 Vac
800	MDN-408	Narrow	42	42	42	42	42
	MDN-608	Narrow	65	65	65	65	65
	MDN-C08	Narrow	100	100	65	20	20
	MDS-408	Standard	42	42	42	42	42
	MDS-608	Standard	65	65	65	65	65
	MDS-808	Standard	85	85	85	85	85
	MDS-C08	Standard	100	100	100	85	85
	MDS-L08 ②	Standard	200	200	200	(2)	(2)
	MDS-X08 ③	Standard	200	200	65	30	30
1200	MDN-412	Narrow	42	42	42	42	42
	MDN-612	Narrow	65	65	65	65	65
	MDN-C12	Narrow	100	100	65	25	25
	MDS-X12	Standard	200	200	65	30	30
	MDS-612	Standard	65	65	65	65	65
	MDS-812	Standard	85	85	85	85	85
	MDS-C12	Standard	100	100	100	85	85
1600	MDN-416	Narrow	42	42	42	42	42
	MDN-516	Narrow	50	50	50	50	50
	MDN-616	Narrow	65	65	65	65	65
	MDN-C16	Narrow	100	100	65	30	30
	MDS-616	Standard	65	65	65	65	65
	MDS-816	Standard	85	85	85	85	85
	MDS-C16	Standard	100	100	100	85	85
	MDS-L16 ②	Standard	200	200	200	(2)	(2)
	MDS-X16 ③	Standard	200	200	65	30	30
2000	MDN-620	Narrow	65	65	65	65	65
	MDN-C20	Narrow	100	100	65	35	35
	MDS-620	Standard	65	65	65	65	65
	MDS-820	Standard	85	85	85	85	85
	MDS-C20	Standard	100	100	100	85	85
	MDS-L20 ②	Standard	200	200	200	(2)	(2)
	MDS-X20 ③	Standard	200	200	65	30	30
	MDS-625	Standard	65	65	65	65	65
2500	MDS-825	Standard	85	85	85	85	85
	MDS-C25	Standard	100	100	100	100	85
	MDS-632	Standard	65	65	65	65	65
3200	MDS-832	Standard	85	85	85	85	85
	MDS-C32	Standard	100	100	100	85	85
	MDS-X32 ③	Double	200	200	—	50	50
	MDS-840	Double	85	85	85	85	85
4000	MDS-C40	Double	100	100	100	100	100
	MDS-H40	Double	130	130	130	130	130
	MDS-X40 ③	Double	200	200	—	50	50
	MDN-640	Double narrow	65	65	65	65	65
	MDN-840	Double narrow	85	85	65	85	65
	MDN-C40	Double narrow	100	100	65	100	65
	MDD-X40	Double	150	150	100	100	100
	MDS-850	Double	85	85	85	85	85
5000	MDD-X50	Double	150	150	100	100	100
	MDS-C50	Double	100	100	100	100	100
	MDS-H50	Double	130	130	130	130	130
	MDS-X50 ③④	Double	200	200	—	50	50
	MDS-C60 ④	Double	100	100	100	100	100
6000	MDS-H60 ④	Double	130	130	130	130	130
	MDD-X60 ④	Double	150	150	100	100	100

① Interrupting ratings shown based on breaker equipped with integral Digitrip™ rms trip unit. Interruption ratings for non-automatic breakers are equal to the published.

② Magnum MDSL current limiting power circuit breaker with integral current limiters. Current limiter selected determines short time and fixed instantaneous trip rating.

③ Magnum MDSX current limiting power circuit breaker with fast opening contacts.

④ Breaker applied in a tested fan cooled enclosure.

Table 4. Magnum DS breaker control voltages and currents

Control voltage	24 dc	48 dc	125 dc	120 ac	240 ac
Close current (SR), ampere	2.70	1.30	0.67	0.59	0.34
Shunt trip current, ampere	2.70	1.30	0.67	0.59	0.34
Spring charge motor, ampere:					
(9 seconds)	N/A	4.00	3.00	3.00	N/A
(5 seconds)	14.00	7.50	3.00	3.00	1.50
Control voltage range:					
Close –	18–26	38–56	100–140	104–127	208–254
Trip –	18–26	28–56	70–140	60–127	208–254

Motor currents are running currents. Inrush is approximately 400%.
Motor running time to charge spring approximately 5 seconds.

Maximum voltages at which the interrupting ratings in **Table 1** apply are:

Table 5. Voltages

System voltage	Maximum voltage
208 or 240	254
480	508
600	635

These interrupting ratings are based on the standard duty cycle consisting of an opening operation, a 15-second interval and a close-open operation, in succession, with delayed tripping in case of short-delay devices.

The standard duty cycle for short-time ratings consists of maintaining the rated current for two periods of 1/2 second each, with a 15-second interval of zero current between the two periods.

Table 6. Available sensor ratings and rating plugs for Digitrip RMS ①

Breaker frame	Available ratings
800	200, 250, 300, 400, 600, 800
1600	200, 250, 300, 400, 600, 800, 1000, 1200, 1600
2000	200, 250, 300, 400, 600, 800, 1000, 1200, 1600, 2000
3200	200, 250, 300, 400, 600, 800, 1000, 1200, 1600, 2000, 2500, 3000, 3200
4000	2000, 2500, 3200, 4000
5000	2000, 2500, 3200, 4000, 5000
6000	2000, 2500, 3200, 4000, 5000

① The rating plug is for 50 and 60 Hz applications. Rating plugs are not interchangeable with 60 Hz or 50 Hz only rating plugs.

The narrow-band characteristic curve graphically illustrates the close coordination obtainable in breaker systems with Digitrip RMS tripping devices. Repeatability is within 2%.

The maximum breaker current rating for any breaker frame size is determined by the rating of the sensor used.

The breaker current rating for any frame size can be changed by simply changing the sensors and associated rating plug, which are easily removed from the breaker drawout element. The wide range of long-delay pickup makes one set of sensors more flexible on a wider range of loads. The Digitrip RMS itself need not be changed when the associated sensors and rating plugs are changed.

Digitrip RMS can be supplied in various combinations of four independent, overcurrent protection functions:

- Long delay (L)
- Instantaneous (I)
- Short delay (S)
- Ground (G)
- Ground alarm only (A)

Every Magnum DS trip unit comes standard with LSI characteristics. Optional ground (G) or ground alarm (GA) may also be provided. These trip units also provide the ability to defeat instantaneous protection. In addition, short delay protection may be set to the maximum instantaneous level, effectively disabling short delay protection. Under no condition is it possible to set the trip unit beyond the capabilities of the circuit breaker.

Table 7. Digitrip RMS adjustable trip settings

Time/current characteristics	Pickup setting	Pickup point (see note)	Time band, seconds
Long delay	0.4, 0.5, 0.6, 0.7, 0.8, 0.9, 0.95, 1.0	I_n times long delay setting	2, 4, 7, 10, 12, 15, 20, 24 (at 6 times pickup value)
Instantaneous	Off, 2, 3, 4, 6, 8, 10, M_1	I_n times short delay setting	—
Short delay	2, 2.5, 3, 4, 6, 8, 10, M_1	I_n times long delay setting	0.1, 0.2, 0.3, 0.4, 0.5 (flat response) 0.1 ①, 0.3 ①, 0.5 ①
Ground fault	0.25, 0.3, 0.35, 0.4, 0.5, 0.6, 0.75, 1.00 (1200 A maximum)	I_n times ground fault setting	0.1, 0.2, 0.3, 0.4, 0.5 (flat response) 0.1 ①, 0.3 ①, 0.5 ①

① I^2t response.

Note:

I_n = Rating plug value
 I_r = Long delay pickup setting times I_n

Table 8. Digitrip ground fault current pickup settings

Installed rating plug (amperes) I _n	Pickup settings—ground fault currents (amperes) ①							
	0.25 ②	0.3 ②	0.35 ②	0.4 ②	0.5 ②	0.6	0.75	1.00
200	50	60	70	80	100	120	150	200
250	63	75	88	100	125	150	188	250
300	75	90	105	120	150	180	225	300
400	100	120	140	160	200	240	300	400
600	150	180	210	240	300	360	450	600
800	200	240	280	320	400	480	600	800
1000	250	300	350	400	500	600	750	1000
1200	300	360	420	480	600	720	900	1200
1600	400	480	560	640	800	960	1200	1200
2000	500	600	700	800	1000	1200	1200	1200
2500	600	720	840	960	1200	1200	1200	1200
3000	750	900	1050	1200	1200	1200	1200	1200
3200	800	960	1200	1200	1200	1200	1200	1200
4000	1000	1200	1200	1200	1200	1200	1200	1200
5000	1200	1200	1200	1200	1200	1200	1200	1200
6000	1200	1200	1200	1200	1200	1200	1200	1200

① Tolerance on pickup levels are ±10% of values shown in chart.

② For testing purposes only: When using an external single-phase current source to test low level ground fault current settings, it is advisable to use the auxiliary power module (APM). Especially when the single-phase current is low, without the APM it may appear as if the trip unit does not respond until the current is well above the set value, leading the tester to believe there is an error in the trip unit when there is none. The reason this occurs is that the single-phase test current is not a good simulation of the normal three-phase circuit. If three-phase had been flowing, the trip unit would have performed correctly. Use the APM for correct trip unit performance when single-phase tests are made.

Table 9. Digitrip ground fault pickup values for secondary injection test kit amperes

Installed rating plug	Sensor rating	Pickup (dial) setting values in secondary amperes ①							
		25% ②	30% ②	35% ②	40% ②	50% ②	60%	75%	100%
200	200	1.25	1.50	1.75	2.00	2.50	3.00	3.75	5.00
250	250	1.25	1.50	1.75	2.00	2.50	3.00	3.75	5.00
300	300	1.25	1.50	1.75	2.00	2.50	3.00	3.75	5.00
400	400	1.25	1.50	1.75	2.00	2.50	3.00	3.75	5.00
600	600	1.25	1.50	1.75	2.00	2.50	3.00	3.75	5.00
800	800	1.25	1.50	1.75	2.00	2.50	3.00	3.75	5.00
1000	1000	1.25	1.50	1.75	2.00	2.50	3.00	3.75	5.00
1200	1200	1.25	1.50	1.75	2.00	2.50	3.00	3.75	5.00
1600	1600	1.25	1.50	1.75	2.00	2.50	3.00	3.75	3.75
2000	2000	1.25	1.50	1.75	2.00	2.50	3.00	3.00	3.00
2500	2500	1.25	1.50	1.75	2.00	2.40	2.40	2.40	2.40
3000	3000	1.25	1.50	1.75	2.00	2.00	2.00	2.00	2.00
3200	3200	1.25	1.50	1.50	1.88	1.88	1.88	1.88	1.88
4000	4000	1.25	1.50	1.50	1.50	1.50	1.50	1.50	1.50
5000	5000	1.20	1.20	1.20	1.20	1.20	1.20	1.20	1.20
6000	6000	1.20	1.20	1.20	1.20	1.20	1.20	1.20	1.20

① Tolerance on pickup levels are ±10% of values shown in chart.

② For testing purposes only: When using an external single-phase current source to test low level ground fault current settings, it is advisable to use the auxiliary power module (APM). Especially when the single-phase current is low, without the APM it may appear as if the trip unit does not respond until the current is well above the set value, leading the tester to believe there is an error in the trip unit when there is none. The reason this occurs is that the single-phase test current is not a good simulation of the normal three-phase circuit. If three-phase had been flowing, the trip unit would have performed correctly. Use the APM for correct trip unit performance when single-phase tests are made.

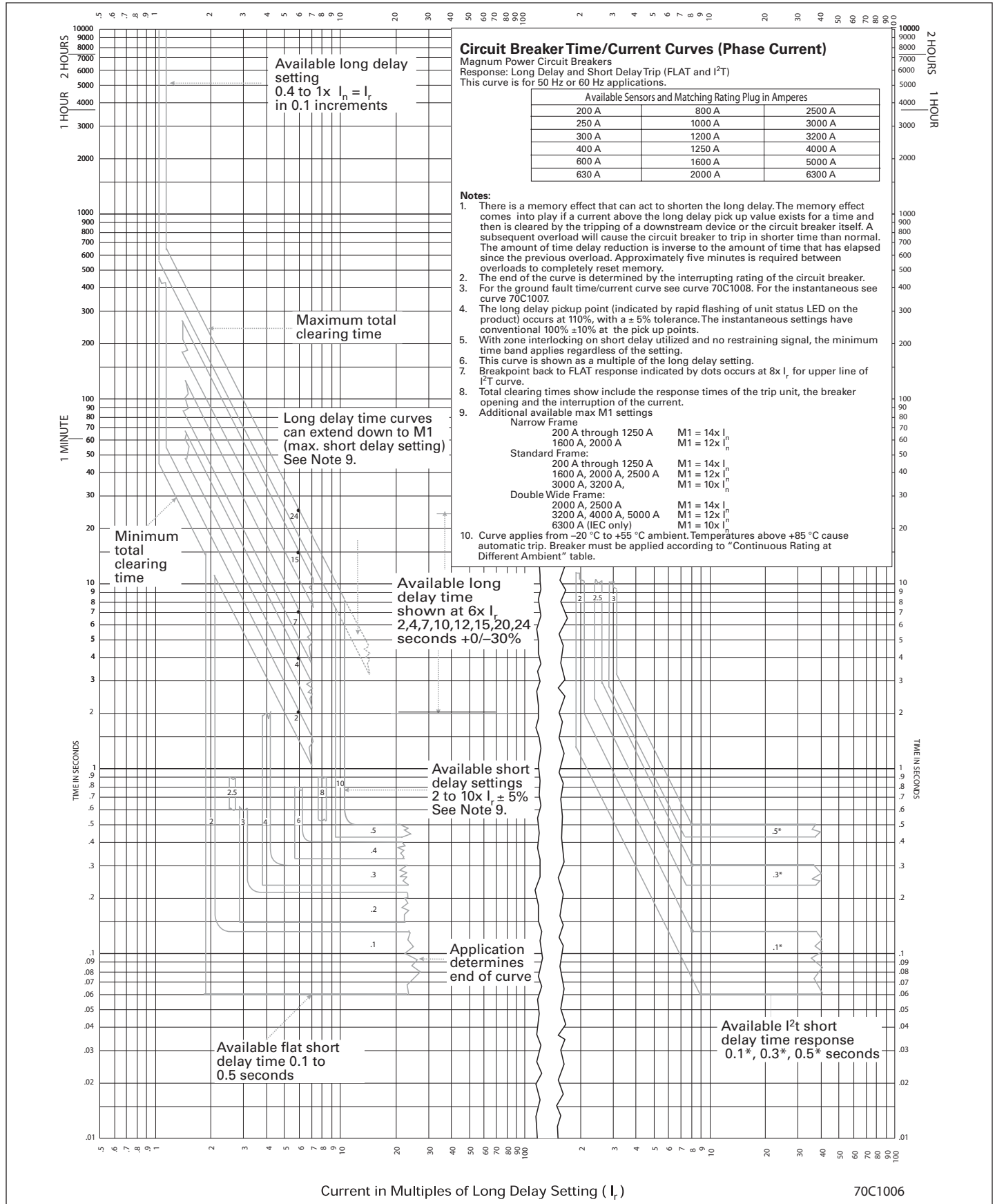

Figure 1. Magnum DS circuit breakers with Digitrip RMS 520/520M/520MC/520i/520Mi/520MCi trip unit typical long delay and short delay time/phase current characteristic curve (LS)

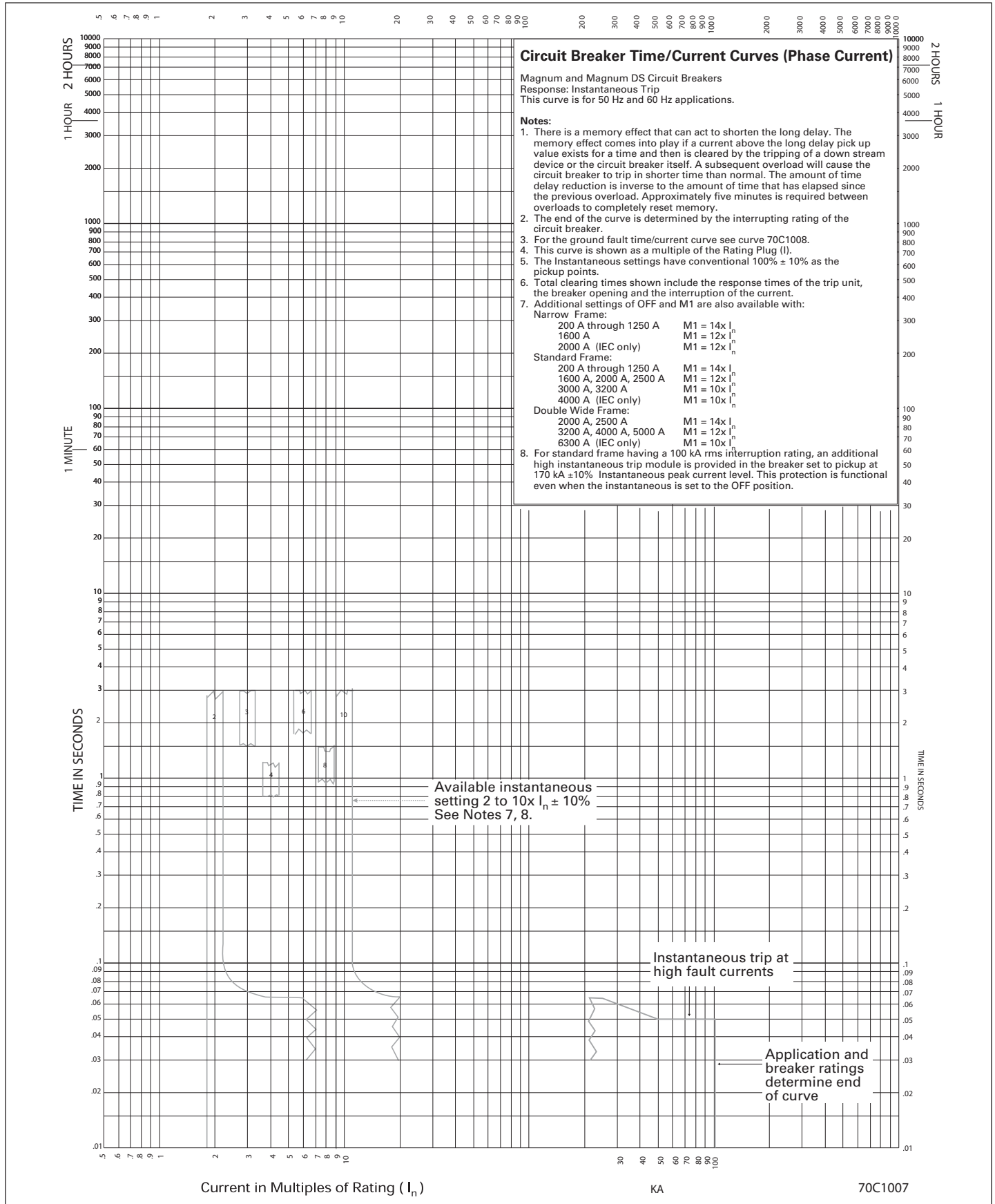

Figure 2. Magnum DS circuit breakers with Digitrip RMS 520/520M/520MC/520i/520Mi/520MCi trip unit typical instantaneous time/phase current characteristic curve (I)

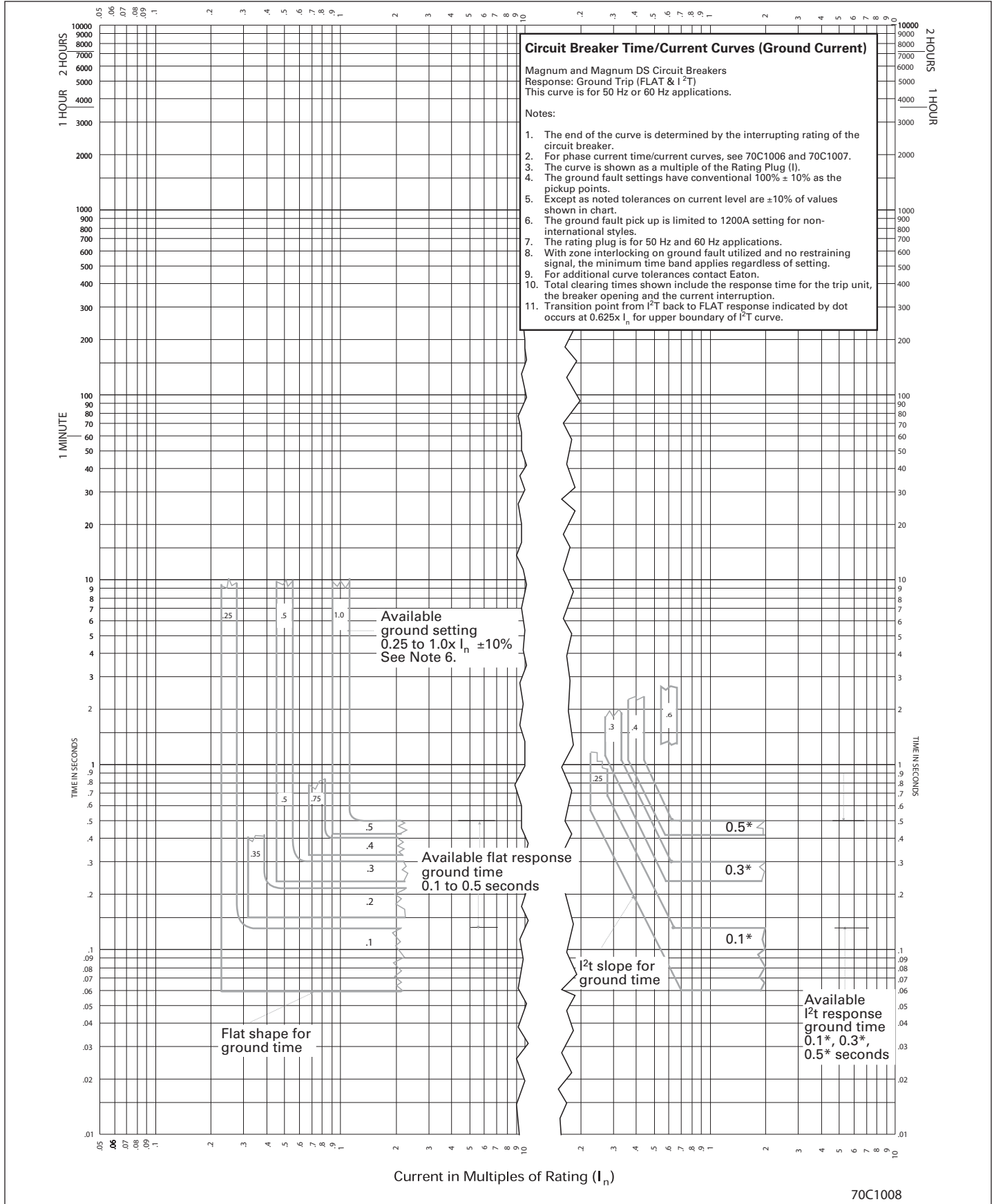

Figure 3. Magnum DS circuit breakers with Digitrip RMS 520/520M/520MC/520i/520Mi/520MCi trip unit typical ground fault time/phase current characteristic curve (G)

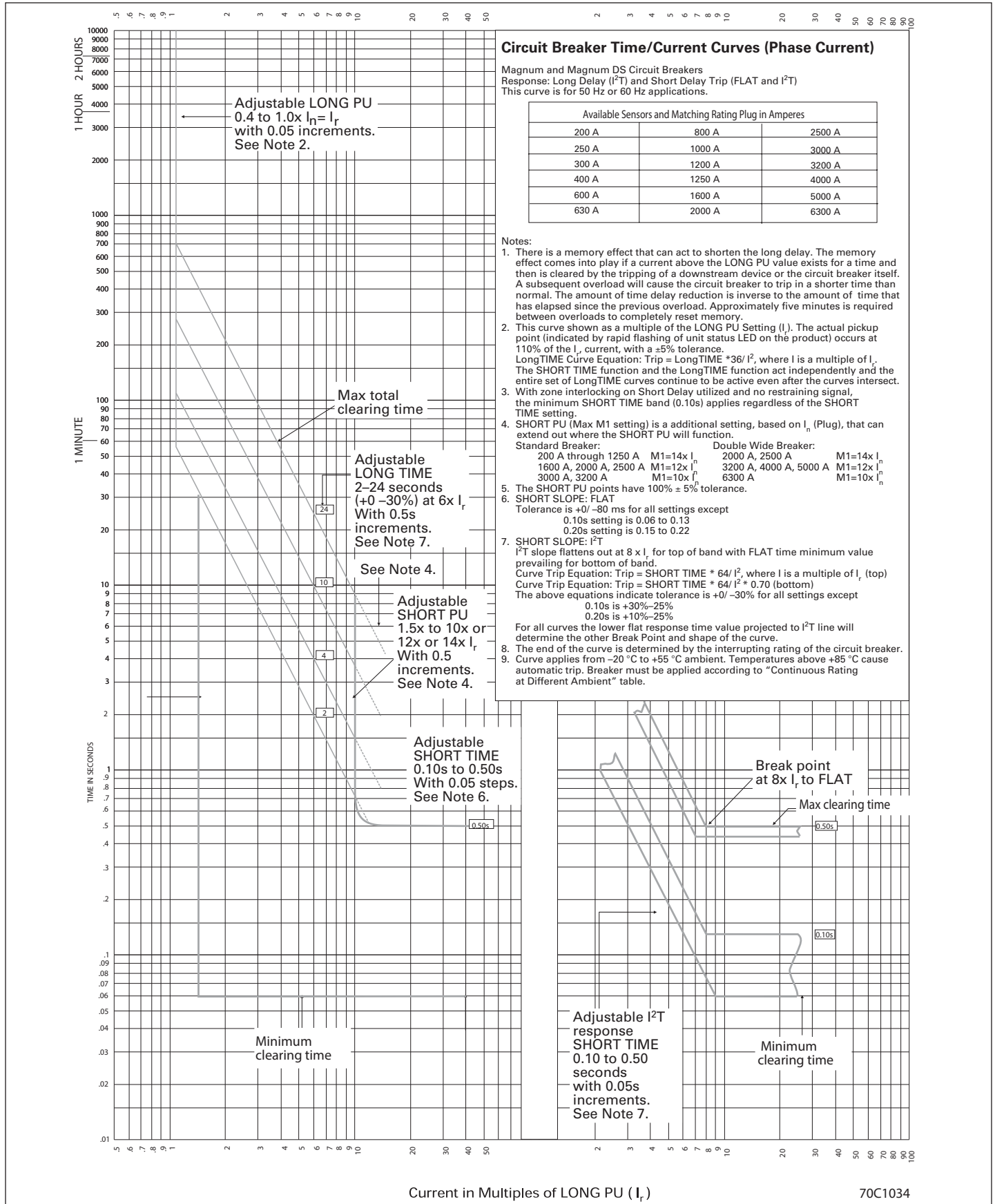

Figure 4. Magnum DS circuit breakers with Digitrip RMS 1150/1150i-I²T trip unit typical long delay and short delay time/phase current characteristic curve (LS)

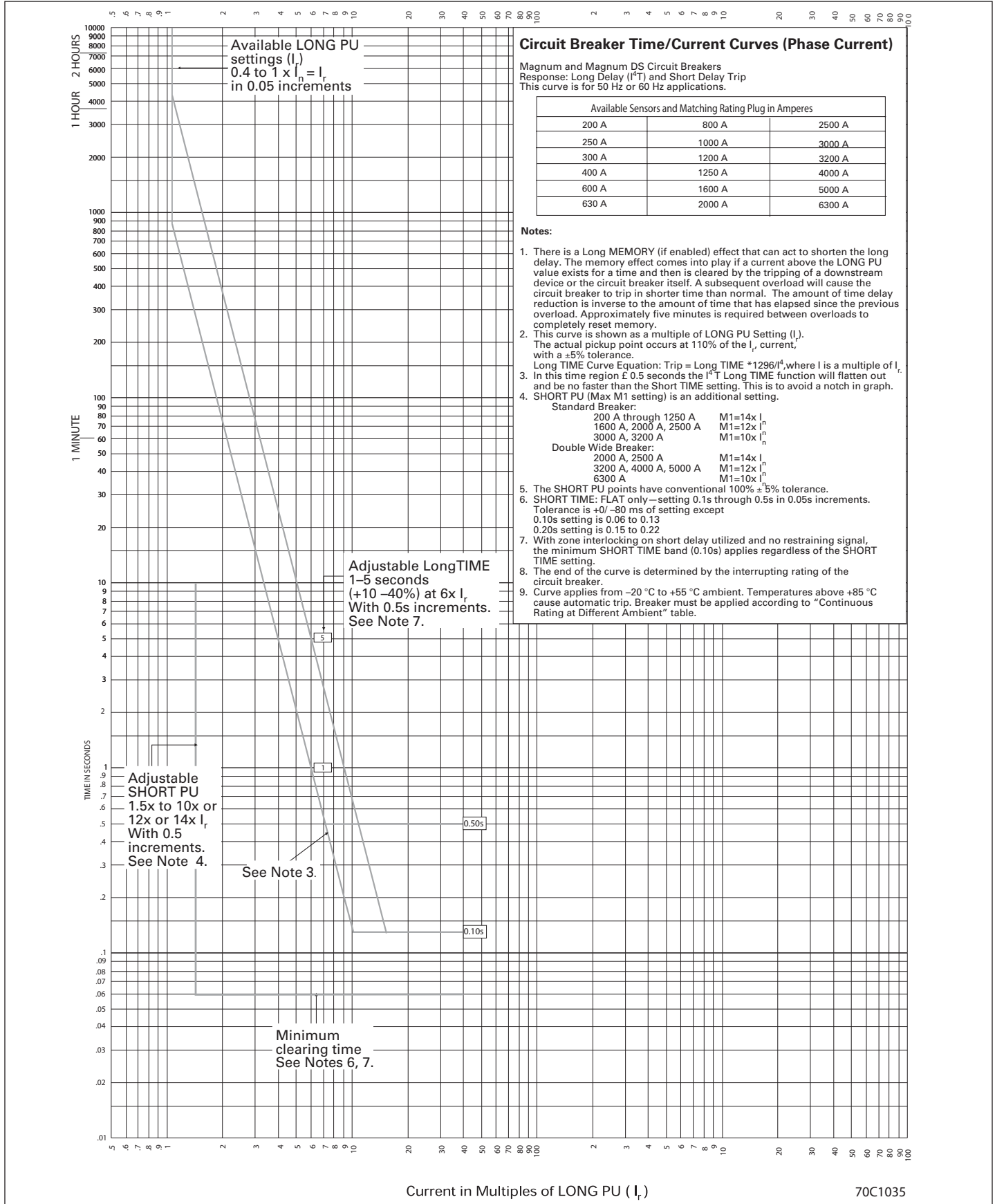

Figure 5. Magnum DS circuit breakers with Digitrip RMS 1150/1150i—I²T trip unit typical long delay and short delay time/phase current characteristic curve (LS)

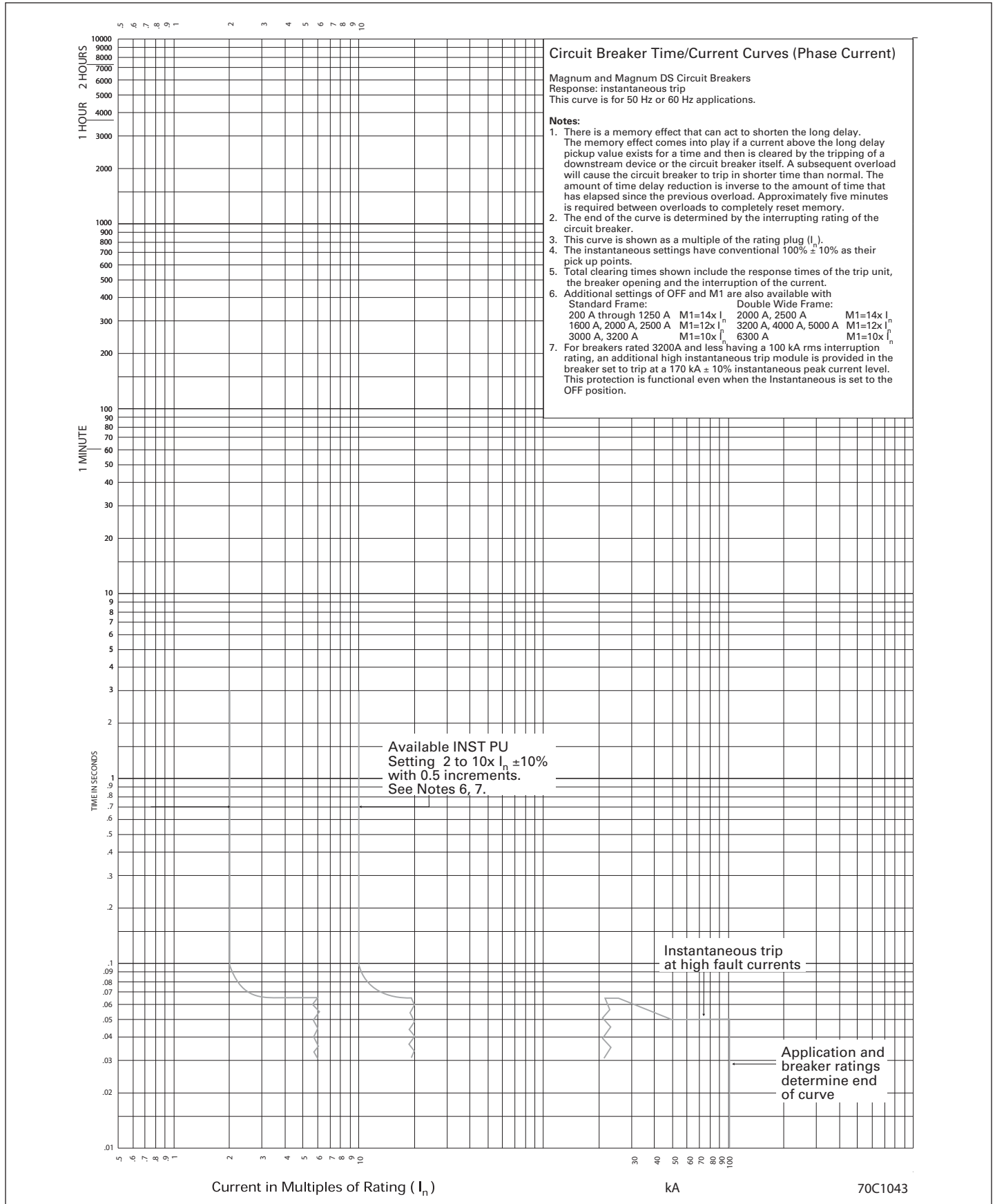

Figure 6. Magnum DS circuit breakers with Digitrip RMS 1150/1150i trip unit typical instantaneous time/phase current characteristic curve (I)

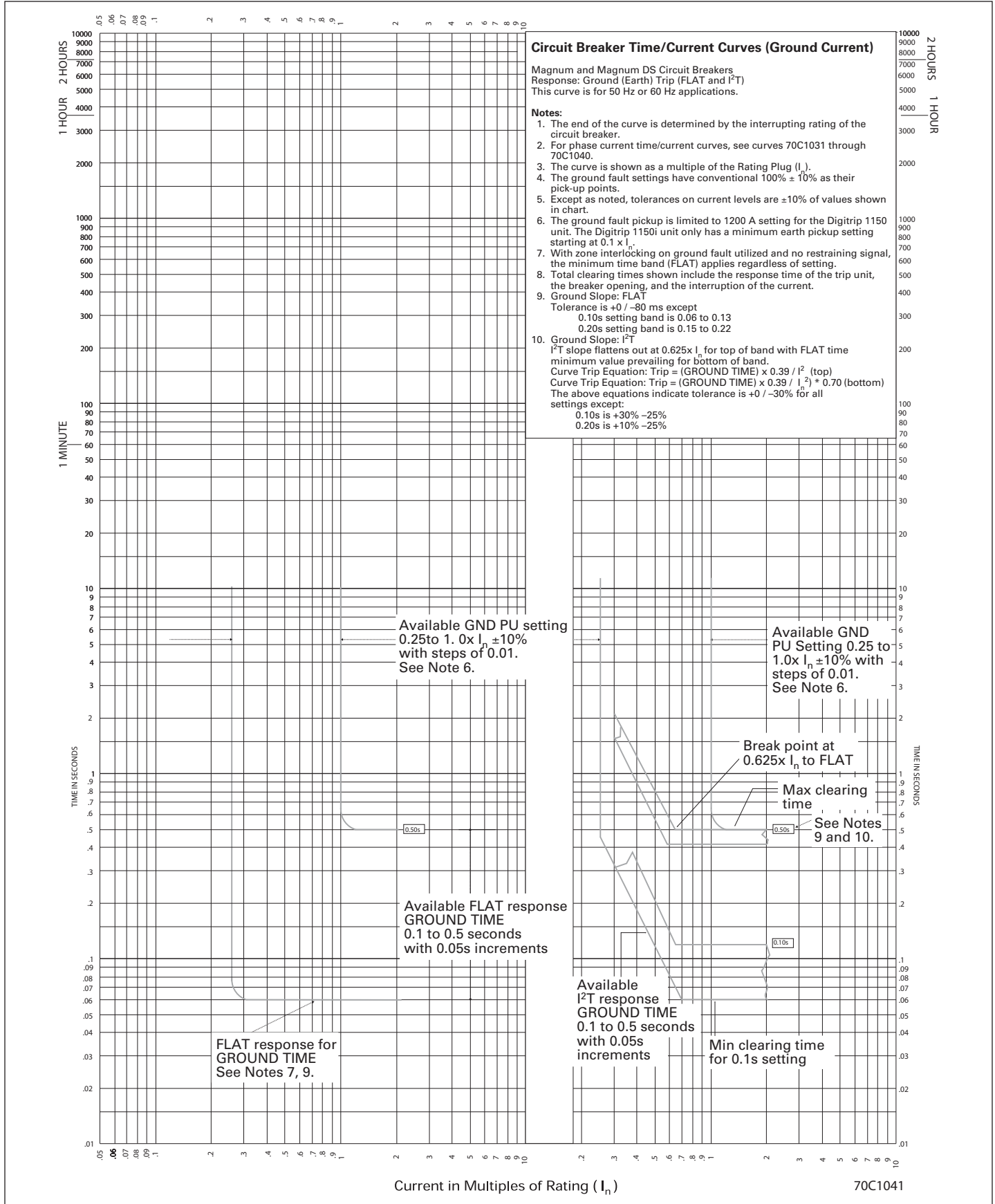

Figure 7. Magnum DS circuit breakers with Digitrip RMS 1150/1150i trip unit typical ground time/phase current characteristic curve (G)

Table 10. Metering type current transformers for mounting in circuit breaker compartments

ANSI meter accuracy classification

Breaker frame rating	Ratio	Ratio	B-0.1	B-0.2	B-0.5	B-0.9	B-1.8
800	100/5	100/1	2.4	—	—	—	—
1600	150/5	150/1	1.2	2.4	—	—	—
2000	200/5	200/1	1.2	2.4	2.4	—	—
	250/5	250/1	0.6	1.2	2.4	—	—
	300/5	300/1	0.6	0.6	1.2	2.4	—
	400/5	400/1	0.3	0.6	1.2	1.2	—
	500/5	500/1	0.3	0.3	0.6	1.2	2.4
	600/5	600/1	0.3	0.3	0.6	1.2	1.2
	750/5	750/1	0.3	0.3	0.3	0.6	1.2
	800/5	800/1	0.3	0.3	0.3	0.6	1.2
	1000/5	1000/1	0.3	0.3	0.3	0.6	0.6
	1200/5	1200/1	0.3	0.3	0.3	0.6	0.6
	1500/5	1500/1	0.3	0.3	0.3	0.6	0.6
	1600/5	1600/1	0.3	0.3	0.3	0.6	0.6
	2000/5	2000/1	0.3	0.3	0.3	0.6	0.3
3200	1600/5	1600/1	0.3	0.3	0.6	0.6	1.2
	2000/5	2000/1	0.3	0.3	0.3	0.6	0.6
	2400/5	2400/1	0.3	0.3	0.3	0.3	0.6
	2500/5	2500/1	0.3	0.3	0.3	0.3	0.3
	3000/5	3000/1	0.3	0.3	0.3	0.3	0.3
	3200/5	3200/1	0.3	0.3	0.3	0.3	0.3
	3500/5	3500/1	0.3	0.3	0.3	0.3	0.3
	4000/5	4000/1	0.3	0.3	0.3	0.3	0.3
4000	4000/5	4000/5	0.3	0.3	0.3	0.3	0.3
5000	5000/5	5000/5	0.3	0.3	0.3	0.3	0.3
6000	6000/5	6000/5	0.3	0.3	0.3	0.3	0.3

Note: Current transformers with meter accuracy classifications at higher burdens and/or suitable for relaying are also available. They will be mounted in the rear cable connection compartment.

Voltage transformers

Insulation Class is 600 volt dielectric, 10 kV full wave BIL. Accuracy Class is 0.6 for W and 1.2 for X burdens at 60 Hz. Thermal ratings are 150 VA at 300 °C and 100 VA at 55 °C. Primary and secondary fuses are mounted on the face of the VT.

Available standard ratios:

- 120:120
- 240:120
- 288:120
- 480:120
- 600:120

Control power transformers

Insulation Class is 600 volt dielectric. Primary and secondary fuses are mounted on the face of the CPT. An optional primary fuse cover is available. 1 kVA, 2 kVA, 3 kVA and 5 kVA ratings are available as standard.

Available standard ratios:

- 208:120/240
- 240:120/240
- 480:120/240
- 600:120/240

Application

Standards

Magnum DS circuit breakers meet or exceed all applicable requirements of ANSI Standards C37.13, C37.17, C37.50 and CSA.

System voltage and frequency

Magnum DS breakers are designed for operation on AC systems only, 60 Hz or 50 Hz, 635 V maximum.

Continuous current ratings

Unlike transformers, generators and motors, circuit breakers are maximum rated devices and have no built-in temporary overload current ratings. Consequently, it is vital that each application take into consideration the maximum anticipated current demand, initial and future, including temporary overloads.

The continuous rating of any Magnum DS breaker is limited to the sensor rating, or the frame size current rating, whichever is the lesser. For instance, an MDS-616 1600 A frame breaker with 800 A sensors has a maximum continuous rating of 800 A, but the same breaker with 1600 A sensors is limited to 1600 A maximum.

All current ratings are based on a maximum ambient air temperature of 40 °C (104 °F).

Ambient temperature

The temperature of the air surrounding the enclosure should be within the limits of: -30 °C (-22 °F) to +40 °C (+104 °F).

Altitude

The breakers are applicable at their full voltage and current ratings up to a maximum altitude of 6600 ft (2012 m) above sea level. When installed at higher altitudes, the ratings are subject to the following correction factors in accordance with ANSI C37.20.1.

Table 11. Altitude derating factors

Altitude		Voltage correction	Current correction
Feet	Meters		
6600	2012	1.000	1.000
7000	2134	0.989	0.998
7500	2286	0.976	0.995
8000	2438	0.963	0.993
8500	2591	0.950	0.990
9000	2743	0.933	0.987
9500	2896	0.917	0.983
10,000	3048	0.900	0.980
10,500	3200	0.883	0.977
11,000	3353	0.867	0.973
11,500	3505	0.850	0.970
12,000	3658	0.833	0.967
12,500	3810	0.817	0.963
13,000	3962	0.800	0.960

Unusual environmental and operating conditions

Special attention should be given to applications subject to the following conditions:

1. Damaging or hazardous fumes, vapors, etc.
2. Excessive or abrasive dust.
For such conditions, it is generally recommended that the switchgear be installed in a clean, dry room, with filtered and/or pressurized clean air. This method permits the use of standard indoor switchgear and avoids the derating effect of non-ventilated enclosures.
3. Salt spray, excessive moisture, dripping, etc.
Drip shields in equipment rooms and space heaters in indoor switchgear, or outdoor weatherproof enclosures, may be indicated, depending upon the severity of the conditions.
4. Excessively high or low ambient temperatures.
For ambient temperatures exceeding 40 °C, and based on a standard temperature rise of 65 °C, the continuous current ratings of breaker frame sizes, and also buses, current transformers, etc., will be subject to a derating factor calculated from the following formula:

$$\sqrt{\frac{105^\circ \text{ Total—Special Ambient, }^\circ\text{C}}{105^\circ \text{ Total—40 }^\circ\text{C Standard Ambient}}}$$

Circuit breakers are not adversely affected by very low outdoor ambient temperatures, particularly when energized and carrying load currents. The standard space heaters in weatherproof switchgear will raise the temperature slightly and prevent condensation.

Electrical components such as relays and instruments, however, must be applied within the manufacturer’s specified limits.

5. Exposure to seismic shock.
Magnum DS assemblies and breakers have been certified for applications through UBC Zone 4 and for the California Building Code. Assembly modifications may be required, so such conditions must be specified.
6. Abnormally high frequency of operation.
In line with above, a lesser number of operations between servicing, and more frequent replacement of parts, may be indicated.

Types of systems

Simple radial (Figure 8)

- Simplest and least costly
- Easy to coordinate

Primary selective radial (Figure 9)

Similar to simple radial, with the added advantage of spare primary incoming cable circuit. By switching to spare circuit, duration of outage from cable failure is limited.

Secondary selective (Figure 10 and Figure 11)

Normally operates as two electrically independent unit substations, with bus tie breaker (T) open, and with approximately half of total load on each bus. In case of failure of either primary incoming circuit, only one bus is affected, and opening main breaker (M) on dead bus and closing tie breaker (T) can promptly restore service. This operation can be made automatic, with duration of outage on either bus limited to a few seconds.

Because the transformers are not continuously paralleled, secondary fault currents and breaker application are similar to those on radial unit substations.

If required, and equipped with the appropriate relaying, either transformer can be removed from service and isolated with no interruption of service on either bus, by first closing the tie breaker and then opening the associated main breaker.

Service continuity and substation capacity can be further improved by substituting selector type primary switches, shown above in B.

Spot network

The transformers are paralleled through network protectors. In case of primary voltage failure, the associated protector automatically opens. The other protector remains closed, and there is no “dead time” on the bus, even momentarily. When primary voltage is restored, the protector automatically checks for synchronism and recloses.

- Secondary voltage regulation is improved by paralleled transformers
- Secondary fault capability is increased by paralleled transformers, and the feeder breakers and bus bracing must be selected accordingly
- Primary switches are usually selector or duplex type, so that transformers can be transferred to alternate live sources, thus shortening duration of overloads

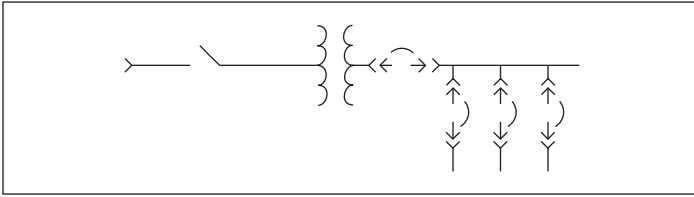

Figure 8. Simple radial

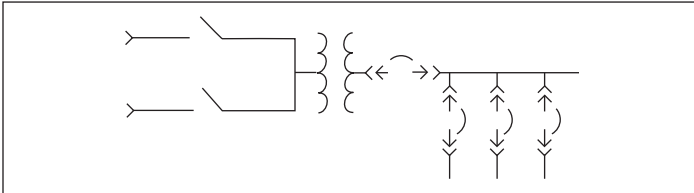

Figure 9. Primary selective radial

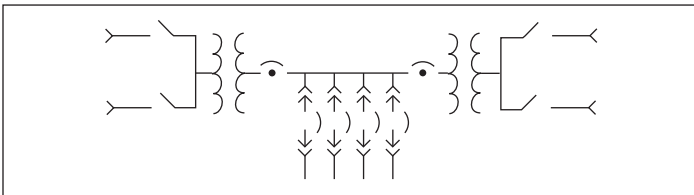

Figure 10. Secondary selective

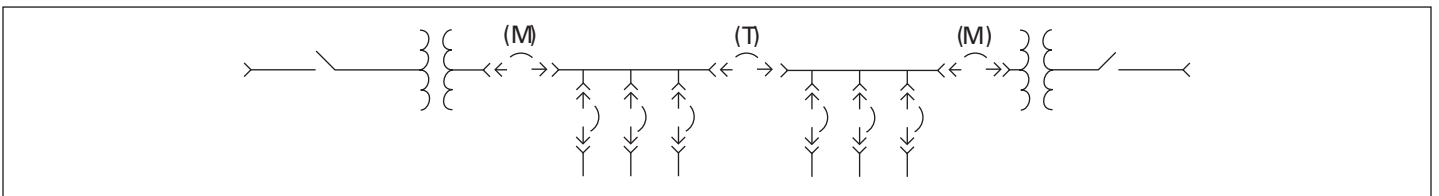

Figure 11. Secondary selective

System application

Most Magnum DS switchgear is fed from power transformers. To facilitate minimum breaker sizing, **Table 12** lists the calculated secondary short circuit currents and applicable main secondary and feeder breakers for various transformer sizes and voltages.

The short-circuit currents are calculated by dividing the transformer basic (100%) rated amperes by the sum of the transformer and primary system impedances, expressed in "per unit." The transformer impedance percentages are standard for most secondary unit substation transformers. The primary impedance is obtained by dividing the transformer base (100%) kVA by the primary short circuit kVA. The motor contributions to the short circuit currents are estimated as approximately 4 times the motor load amperes, which in turn are based upon 50% of the total load for 208 system voltages and 100% for all other voltages.

High transformer impedances and/or lower percentages of motor loads will reduce the short circuit currents correspondingly. Supplementary transformer cooling and temperature ratings will not increase the short circuit currents, provided the motor loads are not increased.

The tables do not apply for three-phase banks of single-phase distribution transformers, which usually have impedances of 2% to 3% or even lower. The short circuit currents must be recalculated for all such applications, and the breakers selected accordingly.

Transformer main secondary breakers

Transformer secondary breakers are required or recommended for one or more of the following purposes:

1. To provide a one-step means of removing all load from the transformer.
2. To provide transformer overload protection in the absence of an individual primary breaker, and/or when primary fuses are used.
3. To provide the fastest clearing of a short circuit in the secondary main bus.
4. To provide a local disconnecting means, in the absence of a local primary switch or breaker, for maintenance purposes.
5. For automatic or manual transfer of loads to alternate sources, as in double-ended secondary selective unit substations.
6. For simplifying key interlocking with primary interrupter switches.
7. To satisfy NEC® service entrance requirements when more than six feeder breakers are required.

Main secondary breakers, as selected in **Table 12**, have adequate interrupting ratings, but not necessarily adequate continuous current ratings. They should be able to carry continuously not only the anticipated maximum continuous output of the transformer but also any temporary overloads. For a fully selective system, instantaneous protection on main breakers should be defeated, as they typically cannot be coordinated with downstream devices. Maximum capabilities of transformers of various types, in terms of kVA and secondary current, are given in **Table 12**. It will be noted that the maximum ratings will often require the substitution of larger frame main breakers than those listed in the tables.

Even if a self-cooled transformer only is considered, it should be remembered that with ratings of 750 kVA and higher, provision for the future addition of cooling fans is automatically included. It is recommended that the main breaker have sufficient capacity for the future fan-cooled rating, plus an allowance for overloads, if possible, particularly since load growth cannot always be predicted.

The same considerations should be given to the main bus capacities and main current transformer ratios.

Bus sectionalizing (tie) breakers

The minimum recommended continuous current rating of bus sectionalizing or tie breakers, as used in double-ended secondary selective unit substations, or for connecting two single-ended substations, is one-half that of the associated main breakers. The interrupting rating should be at least equal to that of the feeder breakers. It is common practice to select the tie breaker of the next frame size below that of the main breakers. However, many users and engineers prefer that the tie breaker be identical to and interchangeable with the main breakers, so that under normal conditions it will be available as a spare main breaker.

In general, the tie breaker, like the main breaker, trip unit should have its instantaneous tripping defeated.

Automatic transfer and intelligent control

Often loads are fed from multiple sources, most often a primary source and an alternate source. In cases where the power source is required to transfer between the normal and alternate source automatically, a transfer system must be utilized. Of course, electrically operated main breakers are necessary to accomplish this transfer.

Suggested transfer logic, description and features for such a transfer is given in Publication No. PA019005EN.

Generator breakers

In most applications where generators are connected through breakers to the secondary bus, they are used as emergency standby sources only, and are not synchronized or paralleled with the unit substation transformers. Under these conditions, the interrupting rating of the generator breaker will be based solely on the generator kVA and sub-transient reactance. This reactance varies with the generator type and rpm, from a minimum of approximately 9% for a two-pole 3600 rpm turbine driven generator to 15% or 20% or more for a medium or slow speed engine type generator. Thus the feeder breakers selected for the unit substation will usually be adequate for a standby generator of the same kVA as the transformer.

Most generators have a 2-hour 25% overload rating, and the generator breaker must be adequate for this overload current. Selective type long and short delay trip protection only is usually recommended for coordination with the feeder breakers, with the long delay elements set at 125% to 150% of the maximum generator current rating for generator protection.

In the case of two or more paralleled generators, anti-motoring reverse power relays (device 32) are recommended for protection of the prime movers, particularly piston type engines. For larger generators requiring a Magnum MDS-632 or larger, voltage-restraint type overcurrent relays (device 51V) are recommended.

Feeder breakers—general

Circuit breakers for feeder circuit protection may be manually or electrically operated, with long and short delay or long delay and instantaneous type trip devices, and trip settings, as required for the specific circuit and load requirements.

Feeder breakers as selected in **Table 12** have adequate interrupting ratings, and are assumed to have adequate continuous current ratings for maximum load demands.

General purpose feeder breakers, such as for lighting circuits, are usually equipped with long delay and instantaneous trip devices, with the long delay pickup set for the maximum load demand in the circuit. Where arcing fault protection is required, the instantaneous trip setting should be as low as practicable consistent with inrush requirements.

Table 12. Guidelines for ground fault protection

System	Advantages	Disadvantages	Equipment available for protection			Notes
			Main breaker	Tie breaker	Feeder breaker	
Ungrounded (three-wire)	Minimum disturbance to service continuity. Currents for the majority of grounds will be limited to capacitance charging current of the system. Can operate with the first ground until it is removed during a regular shutdown. Low cost. Supplemental protection for an ungrounded system utilizing trip unit ground element.	When ground detector shows that a ground exists, corrective action must be taken at the earliest possible shutdown. However, experience indicates that this attention is not always possible. Therefore, these systems tend to operate with one phase grounded through the first uncleared ground. A high impedance ground on another part of the system would result in low values of current, which would not operate a breaker phase trip, and could produce fire damage. High voltages from arcing grounds are possible.	Lamp type ground detector or ground detecting voltmeters with or without voltage transformers. If voltage transformers are used, a ground alarm relay can be added for remote or local alarming. Three-wire residual protection, minimum pickup. 0.50 second time delay. See Figure 18, Figure 21 and Figure 23 on page 22 through page 24 .	Three-wire residual protection, minimum pickup. 0.35 second time delay. See Figure 21 and Figure 23 on page 23 and page 24 .	Three-wire protection, minimum pickup. 0.22 second time delay. See Figure 18, Figure 21 and Figure 23 on page 22 and page 24 .	With proper maintenance this system would result in the minimum disturbance to service continuity.
Solid grounded	Isolation of faults automatic through ground protection system; no overvoltages due to ferroresonance or switching.	Probability of very high ground current and extensive damage; however, normally these high currents are not obtained. Grounds are automatically isolated and continuity of service is interrupted.	Standard residual ground protection for single source systems, and source ground, see Figure 22 on page 24 , for multiple ground sources. Minimum pickup. 0.50 second time delay.	Ground three- or four-wire (as required) fault protection. Minimum pickup. 0.35 second time delay. See Figure 21 and page 24 on page 23 and page 24 .	Ground three- or four-wire (as required) fault protection. Minimum pickup. 0.22 second time delay or zero sequence current transformer feeding into trip unit. See Figure 18, Figure 19 and Figure 23 on page 22 and page 24 .	This is the most common system in use today. As long as it is not necessary to coordinate with phase devices down the line, it will give very good main bus and feeder protection.
High resistance grounded (three-wire)	Ground fault current is limited. Ungrounding can result in high voltages during arcing grounds, and this is corrected by high resistance grounding. Can operate with the first ground until it is removed during a regular shutdown.	Very sensitive detection is required to detect the limited fault current. When the ground detector shows that a ground exists, corrective action must be taken at the earliest possible shutdown. However, experience indicates that this attention is not always possible, therefore, these systems tend to operate with one phase grounded through the first uncleared ground. A high impedance ground on another part of the system would result in low values of current, which would not operate a breaker phase trip, and could produce fire damage. Higher cost than ungrounded.	Same as for ungrounded except ground voltage alarm relay is connected across grounding resistor, or current relay between resistor and ground.	Same as for ungrounded.	Same as for ungrounded.	Same as for ungrounded. This system is most effective when supplied with a pulsing option.

Motor starting feeder breakers

These breakers are usually electrically operated, with long delay and instantaneous tripping characteristics for motor running, locked rotor and fault protection. The breaker sensor rating should be chosen so that the long delay pickup can be set at 125% of motor full load current for motors with a 1.15 service factor, or at 115% for all other motors. Contactors are recommended for this application when there are a number of daily operations involved.

When system short circuits are less than 40 times the motor full load current, the motor breaker tripping characteristic should include a short delay characteristic for greater fault protection.

Group motor feeder breakers

Typical loads for such circuits are motor control centers. The feeder breakers may be either manually or electrically operated as preferred, and are usually equipped with long and short delay trip protection only for coordination with the individual motor circuit devices. The minimum long delay pickup setting should be 115% of the running current of the largest motor in the group, plus the sum of the running circuits of all other motors.

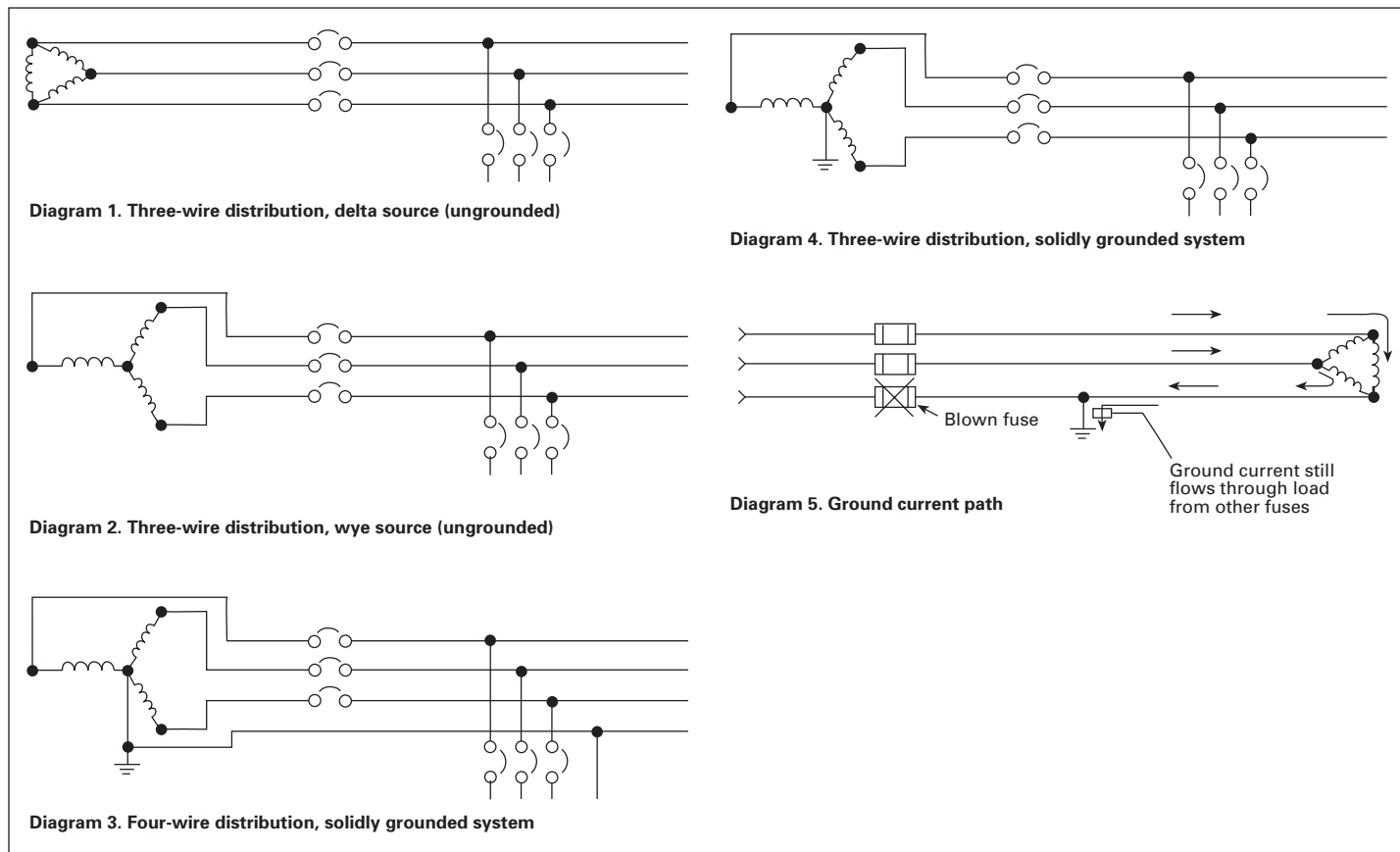

Figure 12. Distribution systems

Ground fault

Distribution systems

The power distribution in three-phase low-voltage systems can be three- or four-wire distribution. The three-wire distribution can be served from either delta or wye sources, but the four-wire distribution is obtained from wye solidly grounded source only.

Diagram 1 in **Figure 12** shows three-wire distribution with delta source and **Diagram 2** in **Figure 12** shows three-wire distribution with wye source. It is significant on **Diagram 2** in **Figure 12**, that the wye connection of a transformer secondary does not necessarily mean four-wire distribution in switchgear. This is worthwhile to note because four-wire distribution is quite frequently assumed when the transformer secondary is wye connected. The low-voltage system is three-phase four-wire distribution only if a fourth wire is carried through the switchgear, the transformer neutral is solidly grounded, and single-phase loads are connected to feeder breakers. This fourth wire is the neutral bus. The neutral bus is connected to the neutral of the wye connected transformer secondary as shown on **Diagram 3** in **Figure 12**.

Three- or four-wire sources can be grounded or ungrounded in service. Generally, where the source is delta connected it is ungrounded, but in some very rare cases it is grounded at one corner of the delta, or at some other point. When the source is wye connected it can be grounded or ungrounded, and when grounded, the grounding is at the neutral. When low-voltage systems are grounded they are generally solidly grounded; however, occasionally the grounding is through a resistor. Three- and four-wire solidly grounded systems are shown on **Diagrams 3** and **4** in **Figure 12**. Most installations are solidly grounded. Solidly grounded systems have the advantage of being the easiest to maintain, yet have the potential for producing extremely high fault levels.

When feeding critical facilities, or continuous industrial processes, it is sometimes preferable to allow the system to continue operating when a phase conductor goes to ground. There are two methods of accommodating this application; the source transformer may either be left ungrounded or high resistance grounded. If the correct system conditions of inductance and capacitance manifests themselves, arcing ground on ungrounded systems can produce escalating line-to-ground voltages, which in turn can lead to insulation breakdown in other devices. This condition is known as ferroresonance. The high resistance grounded system does not suffer from this potential phenomenon. Regardless of which system is selected, both require the application of an appropriate UL recognized ground detection method. Upon grounding of one of the phase conductors, the detection device alerts operators of the condition. Personnel trained to locate these grounds can do so and remove the ground when the process permits, and before a second ground occurs on another phase.

Because ungrounded and resistance grounded systems produce minimal ground current, no damage occurs to the grounded equipment. These ground currents are also too low for detection by integral trip unit ground elements, therefore serve no ground fault tripping function if applied on these systems. Ground fault elements on these types of systems can, however, provide supplemental protection. If a second ground occurs on another phase, and exceeds the ground element pickup setting, the ground element can serve as a more sensitive short delay trip.

Ungrounded or resistance grounded systems can not be applied as four-wire networks. Even if supplied from a four-wire source, no line-to-neutral loads may be served. These applications are limited to three-wire distribution systems only.

Need for ground fault protection

If the magnitude of all ground currents would be large enough to operate the short delay or instantaneous elements of the phase overcurrent trip devices, there would be no need for separate ground fault protection on solidly grounded systems. Unfortunately, because low magnitude ground currents are quite common, this is not the case. Low level ground currents can exist if the ground is in the winding of a motor or a transformer, or if it is a high impedance ground. Low level ground currents may also be due to an arcing type ground. The arcing type grounds are the source of the most severe damages to electrical equipment. The lower limit of the arcing ground currents is unpredictable and the magnitude may be considerably below the setting of the breaker phase overcurrent trip devices. It is for this reason that the National Electrical Code, and UL, require ground fault protection for all service disconnect breakers rated 1000 A and greater, applied on systems with greater than 150 V line-to-ground.

Because the breaker phase overcurrent trip devices cannot provide sensitive enough protection against low magnitude ground faults, there is a need for an additional protective device. This additional device is not to operate on normal overloads and it is to be sensitive and fast enough to protect against low magnitude grounds. It is also important that this additional ground protecting device be simple and reliable. If the Magnum DS breaker solid-state tripping system including an optional "ground element" is selected, good ground fault protection will be ensured.

The ground element

The ground element of the solid-state trip unit is in addition to the usual phase protection. The ground element has adjustable pickup with calibrated marks as shown in **Table 8** and **Table 9** and adjustable time delay. The input current to the trip unit can be provided by:

- A. Residual connection of phase sensors, with the residual circuit connected to the ground element terminals. This is the Magnum DS low-voltage switchgear standard ground protection system for three-wire systems. On four-wire systems, standard ground fault protection includes a fourth "neutral sensor." It is connected to vectorally subtract from the residual current of the phase sensors. Its only function is to sense neutral currents. It does not sense ground current. These systems produce pickup values as shown in **Table 8**.
- B. External ground sensing current transformers connected to the ground element terminals. This means that this external ground sensor will trip the breaker whenever its secondary output current exceeds the values shown in **Table 9**. Tripping is independent of phase currents. The lower the CT ratio, the more sensitive the ground fault protection.

Ground fault protection application and coordination

In all power systems, continuity of service is very important. For reliable service continuity, selective tripping is applied between main, tie, and feeder breakers, and downstream protecting devices, for phase-to-phase faults. Similar selective tripping is desirable when breakers trip on grounds. The application of ground protection only to main breakers may ensure good ground protection. However, it will not provide good service continuity because the main breaker will trip on grounds that should have been cleared by feeder breakers. For proper protection and for good service continuity, main, tie and feeder breakers all should be equipped with ground fault protection.

In view of the above, it is evident that properly applied ground protection requires ground elements as far down the system to the loads as practical. For best results, downstream molded case breakers should have individual ground protection. This would result in excellent ground protection because ground elements of Magnum DS and downstream breakers having similar tripping characteristics can be coordinated.

Depending on the sensitivity of the ground fault protection method applied, coordination between Magnum DS breaker ground elements and downstream branch circuit fuses is sometimes impractical. This is due to the basic fact that the blowing of one phase fuse will not clear a ground on a three-phase system. The other two-phase fuses will let the load "single-phase," and also continue to feed the ground through the load, as shown in **Diagram 5** in **Figure 12**.

High resistance grounding

Where continuity of service is a high priority, high resistance grounding can add the safety of a grounded system while minimizing the risk of service interruptions due to grounds. The concept is a simple one: provide a path for ground current via a resistance that limits the current magnitude, and monitor to determine when an abnormal condition exists.

The ground current path is provided at the point where the service begins, by placing resistance in the connection from system neutral to ground. Control equipment continuously measures ground current. A relay detects when the current exceeds a predetermined level. An alarm alerts building personnel that a ground exists. The system has built-in fault tracing means to assist in finding the source of the ground. An integral transformer provides control power from the primary source.

600 V (maximum) delta systems

To add high resistance grounding to an ungrounded delta-connected system, a neutral point must be created. Three single-phase transformers can be interconnected in a zigzag or wye-broken delta configuration to provide such a neutral point. The transformers and grounding resistors are chosen to limit the ground current to a maximum value of 5 A.

Note: The neutral point may not be used to serve phase-to-neutral loads. Also, this technique may be applied on wye-connected sources when the neutral point is not conveniently accessible from the service entrance location.

600/347 V (maximum) wye systems

To add high resistance grounding to a wye-connected system, resistors are placed in series with the neutral-to-ground connection of the power source. The resistors are chosen to limit the current to a maximum value of 5 A.

Note: Per 1993 NEC 250.5b, Exception No. 5, line-to-neutral loads may not be connected to a system where the neutral is resistance-grounded.

Ground current detection

Any time a system is energized, a small ground current called the “capacitive charging current” will be observed. For low-voltage (600 V and below) systems, this naturally-occurring current is typically 1 A or less.

When one phase becomes grounded, additional current above the charging level will flow. As all ground current must flow through the grounding resistor/grounding transformer assembly, an ammeter in this circuit will read the total amount of ground current. By placing a current-sensing relay in series with the ammeter, the current relay can be adjusted to pick up at a level in excess of the capacitive charging current, thus indicating the abnormal condition.

Alternatively, an optional voltmeter-relay can be connected across the grounding resistors. The voltage across the resistors is proportional to the amount of ground current. The voltmeter-relay’s pickup adjustment is set above the capacitive charging current, to the desired detection level.

In both current and voltage detection methods, the ground current ammeter provides a direct reading of the total, actual AC ground current present in the system at that time. It will be helpful to periodically note the ammeter’s reading; a trend towards higher values may indicate the need for equipment maintenance, and hence reduce the occurrence of unplanned shutdowns.

Indication and alarm circuits

When a fault is detected, an adjustable time delay is provided to override transients. When the time delay has been exceeded, the green “normal” light will turn off, the red “ground fault” light will turn on, and the ground alarm contacts will transfer. If equipped with the optional alarm horn, it will sound.

When the fault is cleared, the current/voltage relay will reset. If the reset control is set on “auto,” the lights will return to “normal” on, “ground fault” off, and the ground alarm contacts will re-transfer. If the reset control is set on “manual,” the lights and relay contacts will remain latched until the operator turns the reset control to “reset.” The lights and ground alarm contacts will then return to normal. The system can be reset only if the fault has been cleared.

During a fault, the optional alarm horn can be silenced at any time by using the “alarm silence” pushbutton. It will not re-sound until either the system is reset, or the re-alarm timer expires. The re-alarm timer is activated by the “alarm silence” control. If the horn has been silenced but the fault has not been cleared, the timer will run. It has a range of 2–48 hours. When the timer times out, the horn will resound, alerting maintenance personnel that the fault has not been cleared.

Test circuit

A test circuit is provided to allow the user to quickly determine that the system is working properly. The test circuit will operate only under normal conditions—it will not allow testing if the system is sensing a fault. A separate grounding resistor is provided, connected to a relay operated by the “test” position of the mode selector switch. The relay’s contact grounds Phase B through the test resistor, causing ground current to flow. The system then reacts as it would under actual system ground conditions: lights transfer, alarm contacts transfer and the (optional) horn sounds.

Pulser circuit

The pulser circuit offers a convenient means to locate the faulted feeder and trace the fault to its origin. The pulser is available any time a fault has been detected. An adjustable recycle timer controls the pulse intervals. The “pulse” light flashes on and off, corresponding to the on-off cycles of the pulser contactor. The pulser contactor switches a bank of resistors on and off, thus allowing a momentary increase in the ground current (approximately a 5 ampere current pulse above the ground current).

Locating a ground fault

The current pulses can be noted with a clamp-on ammeter when the ammeter is placed around the cables or conduit feeding the fault. The operator tests each conduit or set of cables until the pulsing current is noted. By moving the ammeter along the conduit, or checking the conduit periodically along its length, the fault can be traced to its origin. The fault may be located at the point where the pulsing current drops off or stops.

If little or no change in the pulsing current is noted along the entire length of a cable, then the fault may be in the connected load. If the load is a panelboard, distribution switchboard or motor control center, repeat the process of checking all outgoing cable groups to find the faulted feeder. If the fault is not found in an outgoing feeder, the fault may be internal to that equipment.

Note: It may not be possible to precisely locate faults within a conduit. The ground current may divide into many components, depending on the number of cables per phase, number of conduits per feeder, and the number and resistance of each ground point along the conduits. The resulting currents may be too small to allow detection, or may take a path that the ammeter cannot trace. An important note to keep in mind is that while the pulser can greatly aid in locating a fault, there may be certain conditions under which the pulses cannot be readily traced, and other test procedures (megohm, high-potential, etc.) may be needed.

Sequence of operation

Normal

- Green “normal” light on
- Red “ground fault” light off
- White “pulse” light off
- System control switch in “normal” position
- Reset control switch in either “auto” or “manual”

Test

Turn and hold the system control switch in the “test” position. Phase B will be grounded via the test resistor. The ground current will activate the sensing circuit, causing the green “normal” light to turn off and the red “ground fault” light to turn on. The pulser will be activated as well. The white “pulse” light will turn on and off as the pulser contactor closes and opens. The ground current ammeter will display the total ground current, including the incremental pulse current. When ready, return the system control switch to “normal.” The pulser will stop. If the reset control is in the “manual” position, turn it to “reset” to reset the fault sensing circuit. The red “ground fault” light will turn off, and the green “normal” light will turn on. Test mode is not available if the system is detecting a ground. The sensing circuit will disable the test circuit.

Ground fault

When the sensing circuit detects a fault, the green “normal” light will turn off and the red “ground fault” light will turn on. The ground current ammeter will indicate the total ground current. To use the pulser, turn the system control switch to “pulse.” The pulser contactor will cycle on and off as controlled by the recycle timer relay. Use the clamp-on ammeter to locate the faulted feeder. Open the feeder and clear the fault. If the reset control switch is in the “manual” position, turn it to “reset” to reset the sensing circuit. (If reset control is in “auto,” it will reset itself.) When ready to restore service to the load, close the feeder. Return the system control to “normal.”

Zone selective interlocking (ZSI)

By definition, a selectively coordinated system is one where by adjusting trip unit pickup and time delay settings, the circuit breaker closest to the fault trips first. The upstream breaker serves two functions:

1. Backup protection to the downstream breaker.
2. Protection of the conductors between the upstream and downstream breakers. These elements are provided for on Digitrip trip units.

For faults that occur on the conductors between the upstream and downstream breakers it is ideally desirable for the upstream breaker to trip with no time delay. This is the feature provided by zone selective interlocking. Digitrip trip units may be specified to use this option.

Zone selective interlocking is a communication signal between trip units applied on upstream and downstream breakers. Each trip unit must be applied as if zone selective interlocking were not employed, and set for selective coordination.

During fault conditions, each trip unit that senses the fault sends a restraining signal to all upstream trip units. This restraining signal results in causing the upstream trip to continue timing as it is set. In the absence of a restraining signal, the trip unit trips the associated breaker with no intentional time delay, minimizing damage to the fault point. This restraining signal is a very low level. To minimize the potential for induced noise, and to provide a low impedance interface between trip units, special twisted pair conductors are utilized for interconnection. For this reason, zone selective interlocking must be specified.

Ground fault and short delay pickup on Digitrip Trip Units may be specified with zone selective interlocking. Since most system faults start as arcing ground faults, zone selective interlocking on ground fault pickup only is usually adequate. Zone selective interlocking on short delay pickup may be used where no ground fault protection is provided.

Zone selective interlocking may be applied as a type of bus differential protection. It must be recognized, however, that one must accept the minimum pickup of the trip unit for sensitivity.

It must also be recognized that not all systems may be equipped with zone selective Interlocking. Systems containing multiple sources, or where the direction of power flow varies, require special considerations, or may not be suitable for this feature. Digitrip zone interlocking has been tested with up to three levels with up to 20 trip units per level.

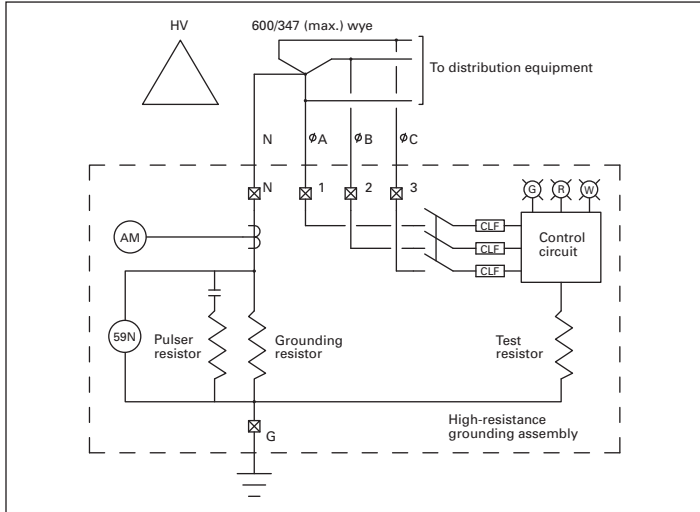

Figure 13. Four-wire system—fault detection via current relay

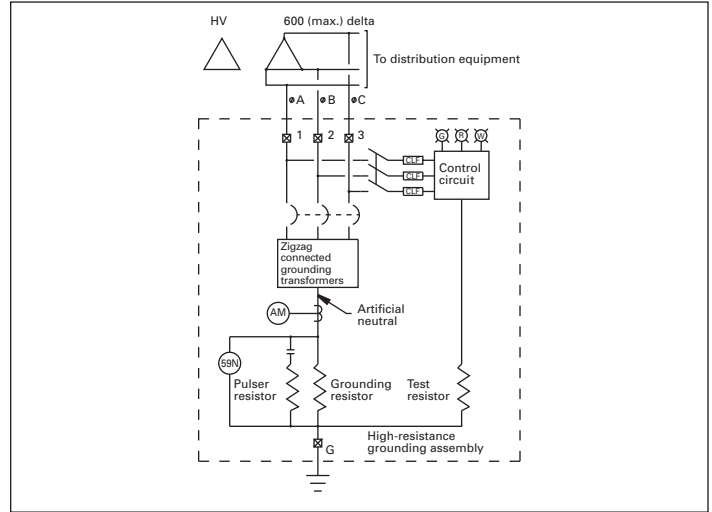

Figure 16. Three-wire system—zig-zag grounding transformers fault detection via voltmeter relay

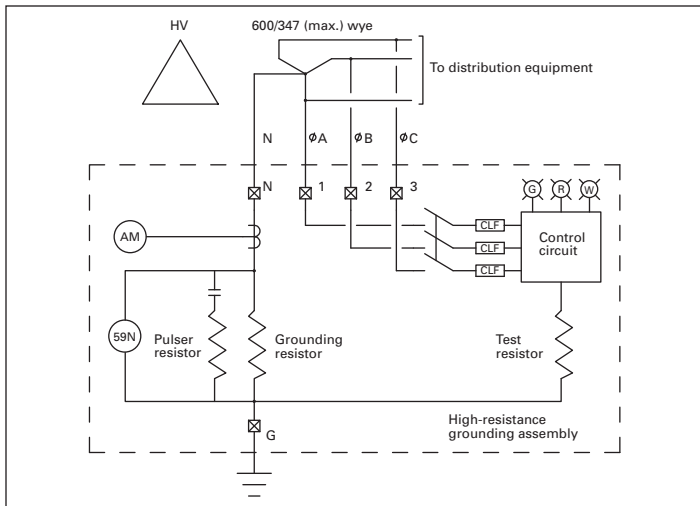

Figure 14. Four-wire system—fault detection via voltmeter relay

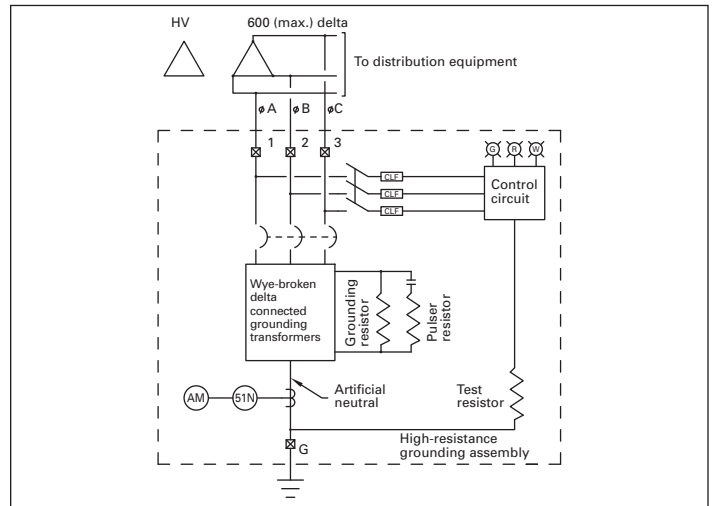

Figure 17. Three-wire system—wye-broken delta grounding transformers fault detection via current relay

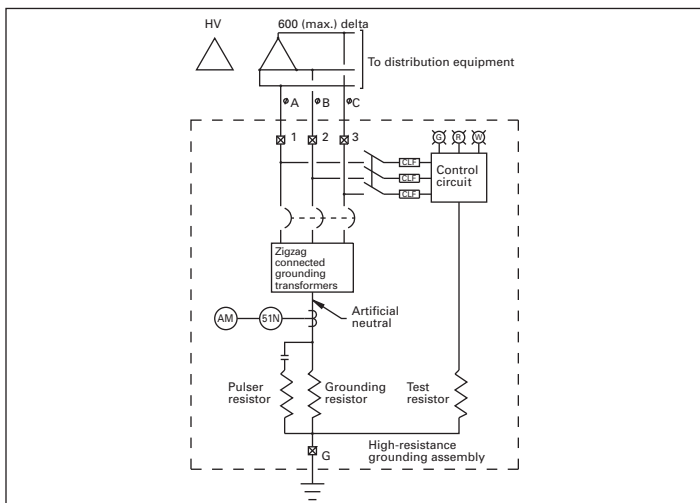

Figure 15. Three-wire system—zig-zag grounding transformers fault detection via current relay

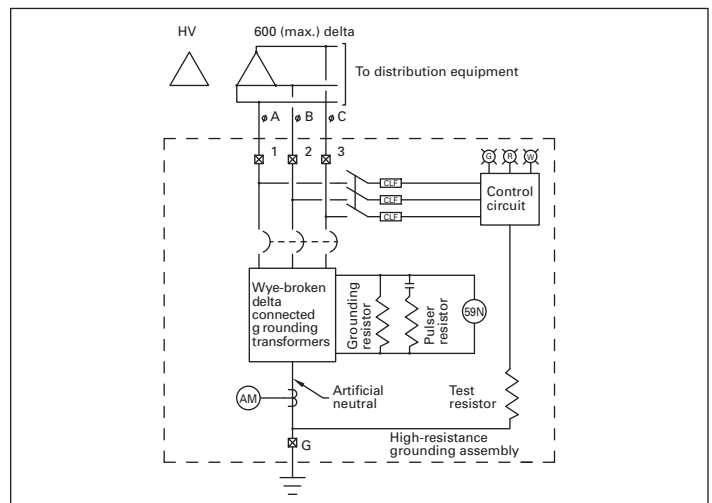

Figure 18. Three-wire system—wye-broken delta grounding transformers fault detection via voltmeter relay

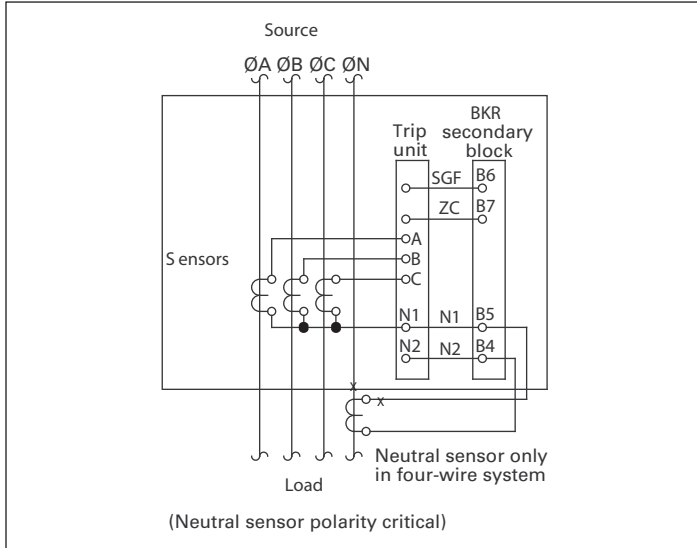

Figure 19. Residual main and feeder breaker ①

① Apply in four-wire systems for main breaker only when no other grounded sources are connected to the same system.

Note: For double-ended secondary unit substations, ground fault protection should be as indicated in **Figure 21** and **Figure 22**; however, for this type of application, the Eaton business should be consulted for the actual bill of materials to be used. The application becomes rather complex if single-phase to neutral loads are being served.

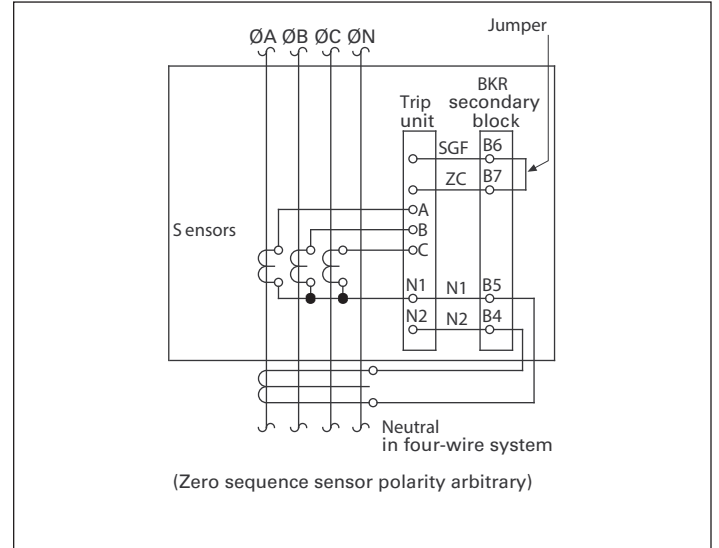

Figure 20. Zero sequence feeder breaker

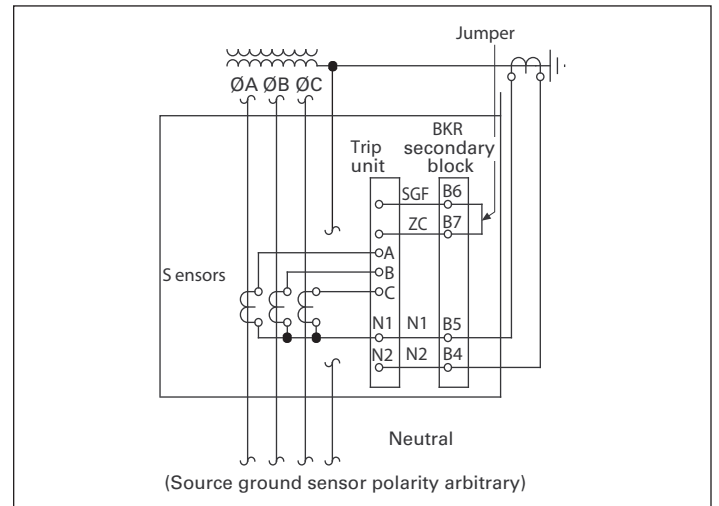

Figure 21. Source neutral main breaker

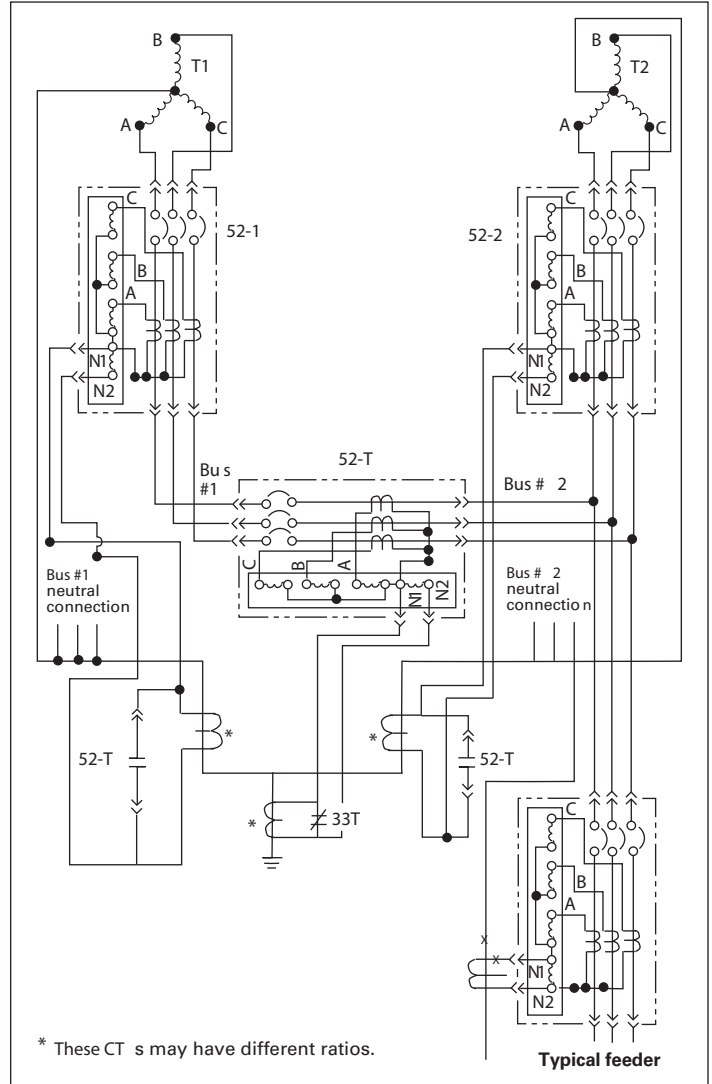
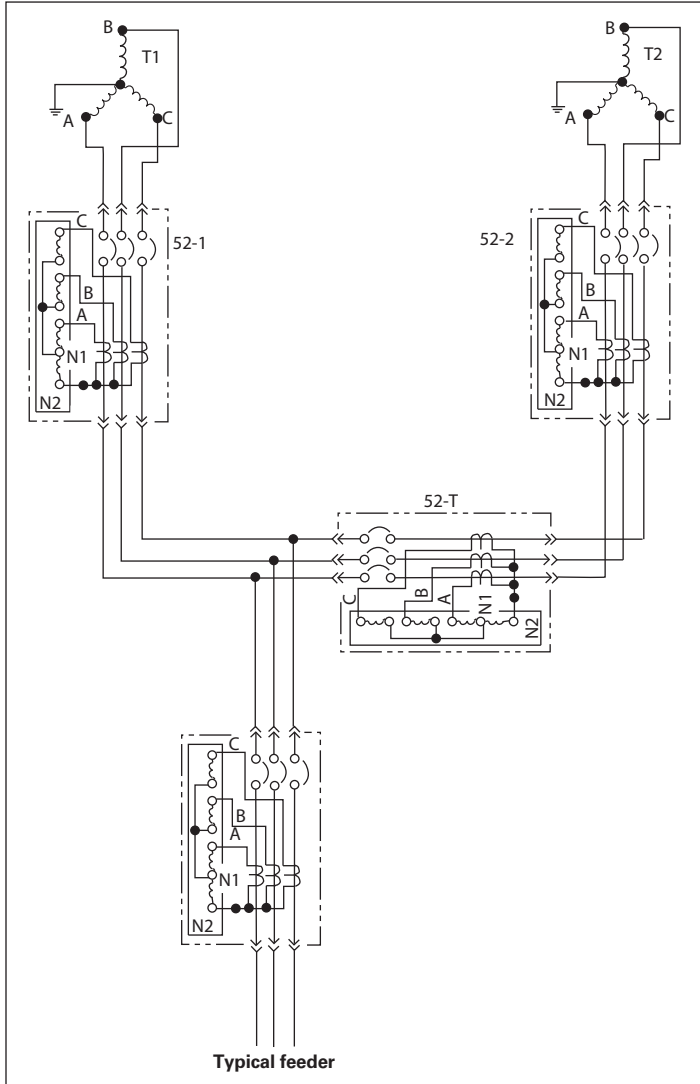

Figure 22. Three-wire double-ended unit substation

Figure 23. Four-wire double-ended unit substation

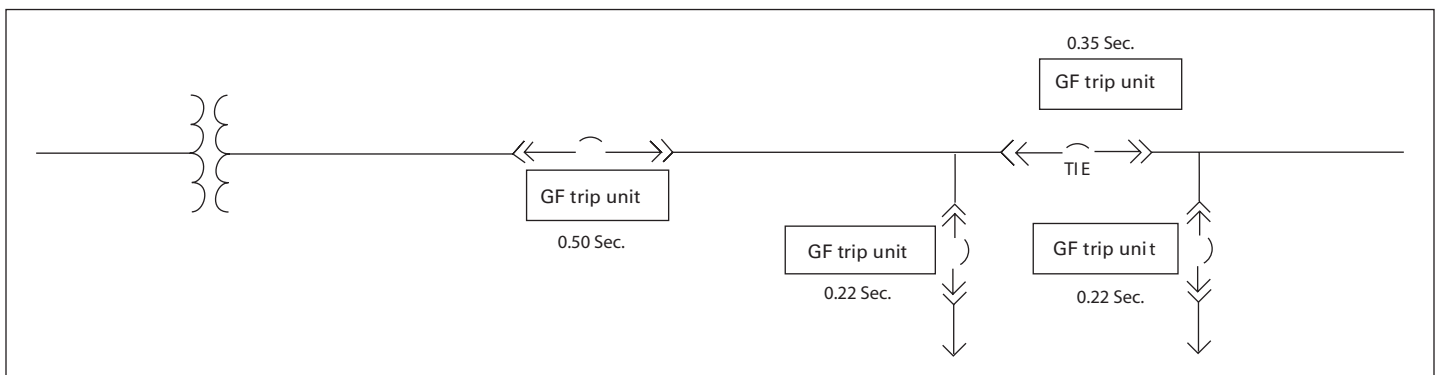

Figure 24. Coordinated ground fault pickup settings

**Table 13. Application of Magnum DS power circuit breakers with standard three-phase transformers—
fluid filled and ventilated dry types**

Transformer base (100%) rating			Secondary short-circuit currents rms symmetrical amperes			Minimum size breakers for selective trip systems		
kVA and percent impedance	Amperes ①	Maximum short- circuit kVA available from primary system	Through transformer only	Motor contribution	Combined	Main breaker short delay trip	Feeder breaker short delay trip	Feeder breaker instantaneous trip
208 V three-phase—50% motor load								
300 5.0%	83	50,000	14,900	1700	16,600	MDS-616	MDS-408	MDS-408
		100,000	15,700		17,400			
		150,000	16,000		17,700			
		250,000	16,300		18,000			
		500,000	16,500		18,200			
		Unlimited	16,700		18,400			
500 5.0%	1389	50,000	23,100	2800	25,900	MDS-616 ②	MDS-408	MDS-408
		100,000	25,200		28,000			
		150,000	26,000		28,800			
		250,000	26,700		29,500			
		500,000	27,200		30,000			
		Unlimited	27,800		30,600			
750 5.75%	2083	50,000	28,700	4200	32,900	MDS-632 ②	MDS-408	MDS-408
		100,000	32,000		36,200			
		150,000	33,300		37,500			
		250,000	34,400		38,600			
		500,000	35,200		39,400			
		Unlimited	36,200		40,400			
1000 5.75%	2778	50,000	35,900	5600	41,500	MDS-632 ②	MDS-408	MDS-408
		100,000	41,200		46,800			
		150,000	43,300		48,900			
		250,000	45,200		50,800			
		500,000	46,700		52,300			
		Unlimited	48,300		53,900			
240 V three-phase—100% motor load								
300 5.0%	722	50,000	12,900	2900	15,800	MDS-408 ②	MDS-408	MDS-408
		100,000	13,600		16,500			
		150,000	13,900		16,800			
		250,000	14,100		17,000			
		500,000	14,300		17,200			
		Unlimited	14,400		17,300			
500 5.0%	1203	50,000	20,000	4800	24,800	MDS-616 ②	MDS-408	MDS-408
		100,000	21,900		26,700			
		150,000	22,500		27,300			
		250,000	23,100		27,900			
		500,000	23,600		28,400			
		Unlimited	24,100		28,900			
750 5.75%	1804	50,000	24,900	7200	32,100	MDS-620 ②	MDS-408	MDS-408
		100,000	27,800		35,000			
		150,000	28,900		36,100			
		250,000	29,800		37,000			
		500,000	30,600		37,800			
		Unlimited	31,400		38,600			
1000 5.75%	2406	50,000	31,000	9600	40,600	MDS-632 ②	MDS-408	MDS-408
		100,000	35,600		45,200			
		150,000	37,500		47,100			
		250,000	39,100		48,700			
		500,000	40,400		50,000			
		Unlimited	41,800		51,400			

① At transformer self-cooled rating.

② Next larger frame size main breaker may be required for 55/65 °C rise and/or forced air-cooled (FA) transformer. Check transformer secondary ampere rating.

Table 13. Application of Magnum DS power circuit breakers with standard three-phase transformers—fluid filled and ventilated dry types (continued)

Transformer base (100%) rating			Secondary short-circuit currents rms symmetrical amperes			Minimum size breakers for selective trip systems		
kVA and percent impedance	Amperes ①	Maximum short-circuit kVA available from primary system	Through transformer only	Motor contribution	Combined	Main breaker short delay trip	Feeder breaker short delay trip	Feeder breaker instantaneous trip
480 V three-phase—100% motor load								
500 5–0%	601	50,000	10,000	2400	12,400	MDS-408 ②	MDS-408	MDS-408
		100,000	10,900		13,300		MDS-408	MDS-408
		150,000	11,300		13,700		MDS-408	MDS-408
		250,000	11,600		14,000		MDS-408	MDS-408
		500,000	11,800		14,200		MDS-408	MDS-408
		Unlimited	12,000		14,400		MDS-408	MDS-408
750 5.75%	902	50,000	12,400	3600	16,000	MDS-616	MDS-408	MDS-408
		100,000	13,900		17,500		MDS-408	MDS-408
		150,000	14,400		18,000		MDS-408	MDS-408
		250,000	14,900		18,500		MDS-408	MDS-408
		500,000	15,300		18,900		MDS-408	MDS-408
		Unlimited	15,700		19,300		MDS-408	MDS-408
1000 5.75%	1203	50,000	15,500	4800	20,300	MDS-616 ②	MDS-408	MDS-408
		100,000	17,800		22,600		MDS-408	MDS-408
		150,000	18,700		23,500		MDS-408	MDS-408
		250,000	19,600		24,400		MDS-408	MDS-408
		500,000	20,200		25,000		MDS-408	MDS-408
		Unlimited	20,900		25,700		MDS-408	MDS-408
1500 5.75%	1804	50,000	20,600	7200	27,800	MDS-620 ②	MDS-408	MDS-408
		100,000	24,900		32,100		MDS-408	MDS-408
		150,000	26,700		33,900		MDS-408	MDS-408
		250,000	28,400		35,600		MDS-408	MDS-408
		500,000	29,800		37,000		MDS-408	MDS-408
		Unlimited	31,400		38,600		MDS-408	MDS-408
2000 5.75%	2406	50,000	24,700	9600	34,300	MDS-632 ②	MDS-408	MDS-408
		100,000	31,000		40,600		MDS-408	MDS-408
		150,000	34,000		43,600		MDS-608	MDS-608
		250,000	36,700		46,300		MDS-608	MDS-608
		500,000	39,100		48,700		MDS-608	MDS-608
		Unlimited	41,800		51,400		MDS-608	MDS-608
2500 5.75%	3008	50,000	28,000	12000	40,000	MDS-632 ②	MDS-408	MDS-408
		100,000	36,500		48,500		MDS-608	MDS-608
		150,000	40,500		52,500		MDS-608	MDS-608
		250,000	44,600		56,600		MDS-608	MDS-608
		500,000	48,100		60,100		MDS-608	MDS-608
		Unlimited	52,300		64,300		MDS-608	MDS-608
3000 5.75%	3609	50,000	30,700	14000	44,700	MDS-840 ②	MDS-608	MDS-608
		100,000	41,200		55,200		MDS-608	MDS-608
		150,000	46,600		60,600		MDS-608	MDS-608
		250,000	51,900		65,900		MDS-808	MDS-808
		500,000	56,800		70,800		MDS-808	MDS-808
		Unlimited	62,800		76,800		MDS-808	MDS-808
3750 5.75%	4511	50,000	34,000	18000	52,000	MDS-850	MDS-608	MDS-608
		100,000	47,500		65,500		MDS-808	MDS-808
		150,000	54,700		72,700		MDS-808	MDS-808
		250,000	62,200		80,200		MDS-808	MDS-808
		500,000	69,400		87,400		MDS-L08	MDS-C08
		Unlimited	78,500		96,500		MDS-L08	MDS-C08

① At transformer self-cooled rating.

② Next larger frame size main breaker may be required for 55/65 °C rise and/or forced air-cooled (FA) transformer. Check transformer secondary ampere rating.

**Table 13. Application of Magnum DS power circuit breakers with standard three-phase transformers—
fluid filled and ventilated dry types (continued)**

Transformer base (100%) rating			Secondary short-circuit currents rms symmetrical amperes			Minimum size breakers for selective trip systems		
kVA and percent impedance	Amperes ①	Maximum short- circuit kVA available from primary system	Through transformer only	Motor contribution	Combined	Main breaker short delay trip	Feeder breaker short delay trip	Feeder breaker instantaneous trip
600 V three-phase—100% motor load								
500 5.0%	481	50,000	8,000	1900	9,900	MDS-408	MDS-408	MDS-408
		100,000	8,700		10,600			
		150,000	9,000		10,900			
		250,000	9,300		11,200			
		500,000	9,400		11,300			
		Unlimited	9,600		11,500			
750 5.75%	722	50,000	10,000	2900	12,900	MDS-408 ②	MDS-408	MDS-408
		100,000	11,100		14,000			
		150,000	11,600		14,500			
		250,000	11,900		14,800			
		500,000	12,200		15,100			
		Unlimited	12,600		15,500			
1000 5.75%	962	50,000	12,400	3900	16,300	MDS-616	MDS-408	MDS-408
		100,000	14,300		18,200			
		150,000	15,000		18,900			
		250,000	15,600		19,500			
		500,000	16,200		20,100			
		Unlimited	16,700		20,600			
1500 5.75%	1443	50,000	16,500	5800	22,300	MDS-616 ②	MDS-408	MDS-408
		100,000	20,000		25,800			
		150,000	21,400		27,200			
		250,000	22,700		28,500			
		500,000	23,900		29,700			
		Unlimited	25,100		30,900			
2000 5.75%	1924	50,000	19,700	7700	27,400	MDS-620 ②	MDS-408	MDS-408
		100,000	24,800		32,500			
		150,000	27,200		34,900			
		250,000	29,400		37,100			
		500,000	31,300		39,000			
		Unlimited	33,500		41,200			
2500 5.75%	2406	50,000	22,400	9600	32,000	MDS-632 ②	MDS-408	MDS-408
		100,000	29,200		38,800			
		150,000	32,400		42,000			
		250,000	35,600		45,200			
		500,000	38,500		48,100			
		Unlimited	41,800		51,400			
3000 5.75%	2886	50,000	24,600	11500	36,100	MDS-632 ②	MDS-408	MDS-408
		100,000	33,000		44,500			
		150,000	37,300		48,800			
		250,000	41,500		53,000			
		500,000	45,500		57,000			
		Unlimited	50,200		61,700			
3750 5.75%	3608	50,000	27,200	14400	41,600	MDS-840 ②	MDS-408	MDS-408
		100,000	38,000		52,400			
		150,000	43,700		58,100			
		250,000	49,800		64,200			
		500,000	55,500		69,900			
		Unlimited	62,800		77,200			

① At transformer self-cooled rating.

② Next larger frame size main breaker may be required for 55/65 °C rise and/or forced air-cooled (FA) transformer. Check transformer secondary ampere rating.

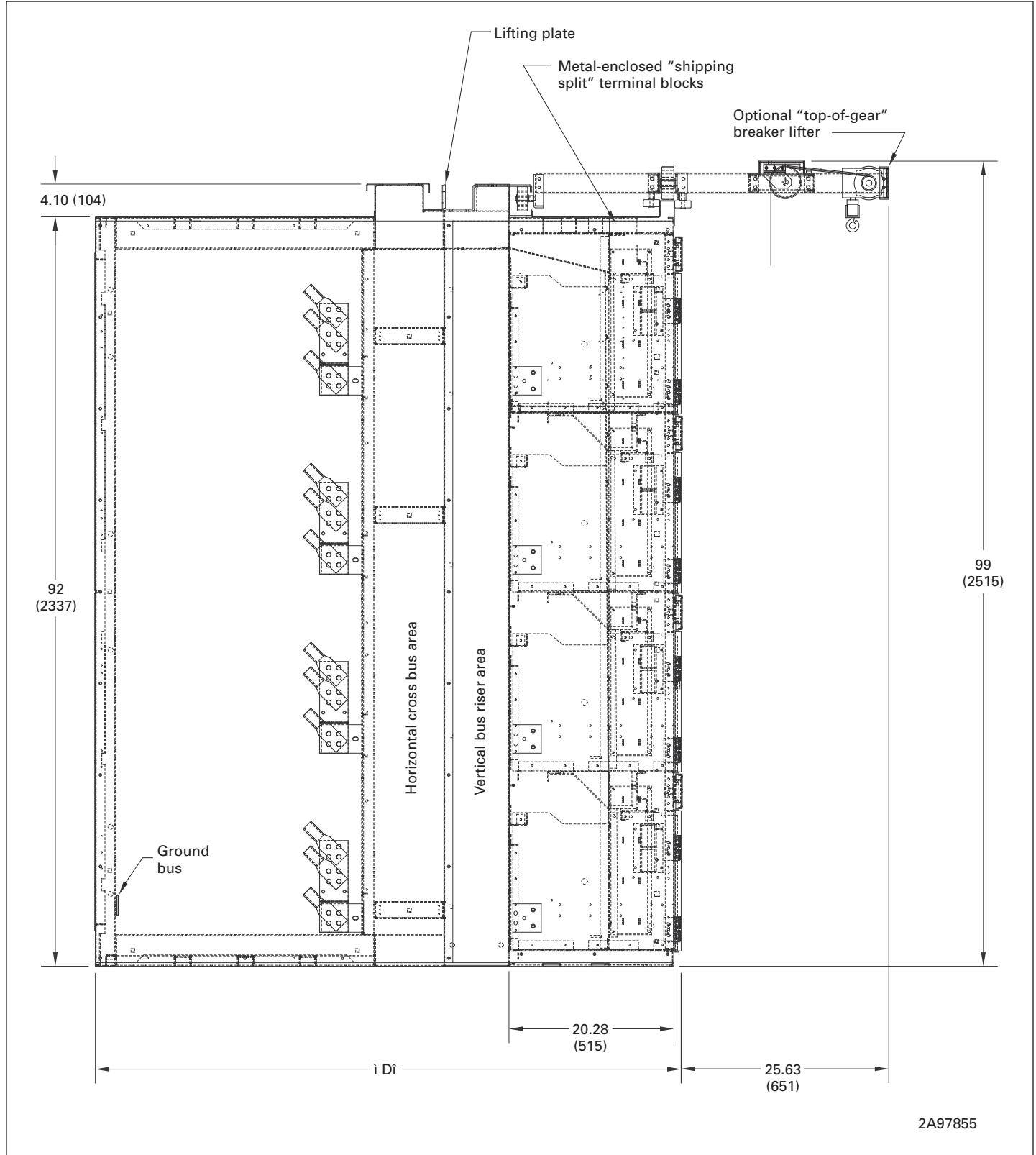

Figure 25. Section view of typical structure—dimensions in inches (mm)

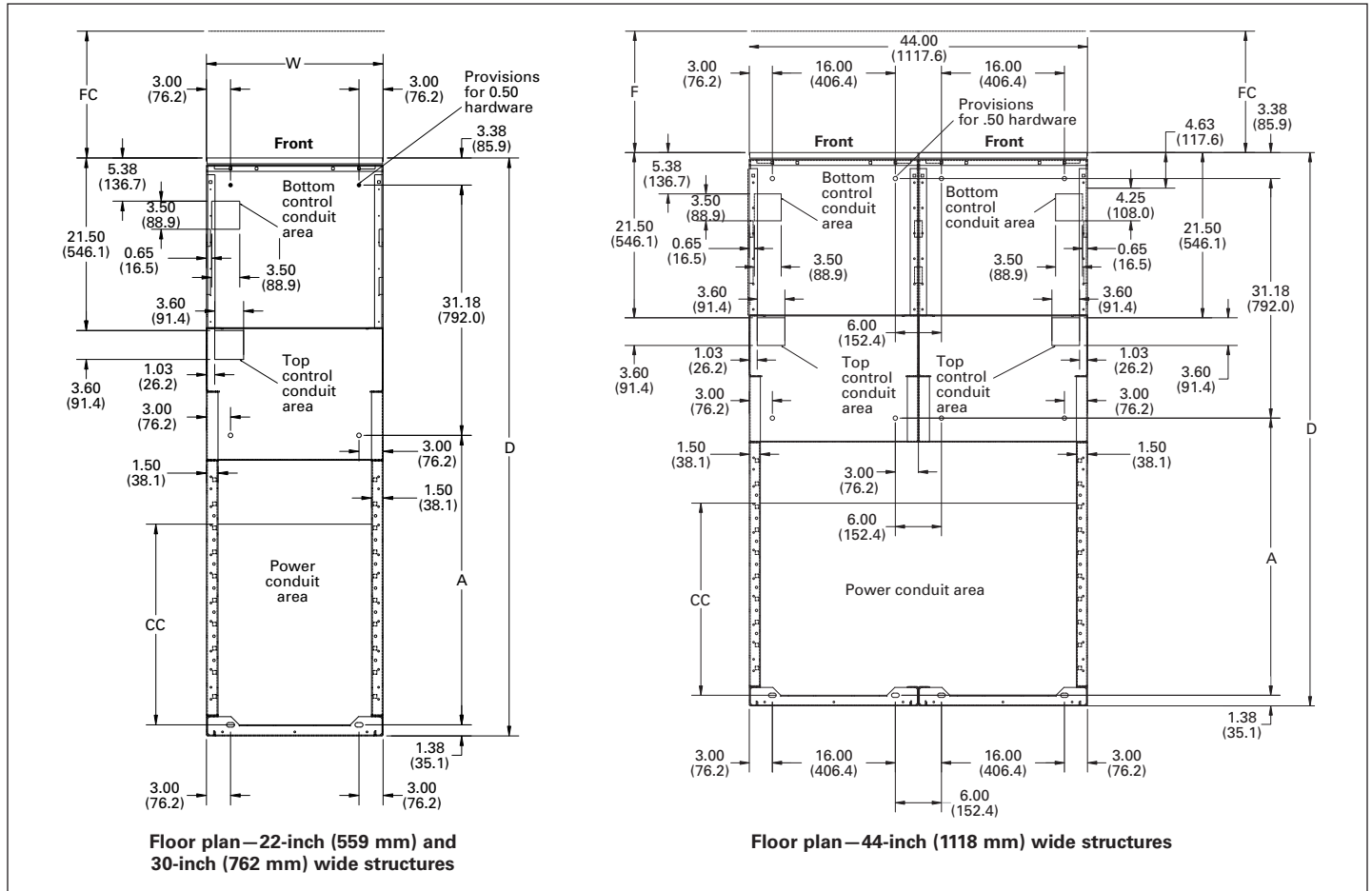

Figure 26. Section view of typical structure—dimensions in inches (mm)

Table 14. Dimensions in inches (mm)

FC ①	W	D ②	A ③	CC ④⑤	Recommended number of power conduits (maximum) ⑥	
					3.5-inch (88.9)	4-inch (101.6)
36 (914.4)	22 (558.8)	54 (1371.6)	18 (457.2)	7.3 (185.4)	3	3
		60 (1524.0)	24 (609.6)	13.3 (337.8)	6	6
		66 (1676.4)	30 (762.0)	19.3 (490.2)	9	9
		72 (1828.8)	36 (914.4)	25.3 (642.6)	12	12
		78 (1981.2)	42 (1066.8)	31.3 (795.0)	15	15
		84 (2133.6)	48 (1219.2)	37.3 (947.3)	18	18
36 (914.4)	30 (762.0)	54 (1371.6)	18 (457.2)	7.3 (185.4)	4	4
		60 (1524.0)	24 (609.6)	13.3 (337.8)	8	8
		66 (1676.4)	30 (762.0)	19.3 (490.2)	12	12
		72 (1828.8)	36 (914.4)	25.3 (642.6)	16	16
		78 (1981.2)	42 (1066.8)	31.3 (795.0)	20	20
		84 (2133.6)	48 (1219.2)	37.3 (947.3)	24	24
36 (914.4)	44 (1117.6)	54 (1371.6)	18 (457.2)	7.3 (185.4)	7	7
		60 (1524.0)	24 (609.6)	13.3 (337.8)	14	14
		66 (1676.4)	30 (762.0)	19.3 (490.2)	21	21
		72 (1828.8)	36 (914.4)	25.3 (642.6)	28	28
		78 (1981.2)	42 (1066.8)	31.3 (795.0)	35	35
		84 (2133.6)	48 (1219.2)	37.3 (947.3)	42	42
		90 (2286.0)	54 (1371.6)	43.3 (1099.8)	49	49

① FC is the recommended front clearance for breaker removal with top-of-switchgear-mounted breaker lifter. If a portable breaker lifter is to be used, allow at least 84 inches (2134 mm) of aisle space.

② Hinged rear doors add 1.25 inches (32 mm).

③ Bolt hole location for mounting the center floor channel when required. Floor channels not included.

④ When a zero-sequence ground-fault CT is mounted on line-side or load-side of a breaker, reduce CC dimension by 10 inches (254 mm).

⑤ For available area for bus duct connection contact the Eaton business.

⑥ Stub conduit 2 inches (50 mm) maximum in power cable area, 1-inch (25 mm) maximum in control wiring area.

Center of gravity location

For seismic calculations, the following dimensions should be used to locate the center of gravity for indoor Magnum DS switchgear.

Table 15. Center of gravity location

Axis	Position
X (vertical)	60 inches (1524 mm)
Y (left-to-right)	Center of lineup
Z (from the front)	26 inches (660 mm)

Table 16. Heat loss data ①

Estimated heat loss per breaker (watts)

Breaker frame	Fixed mounting	Drawout mounting
800	60	150
1600	150	329
2000	172	374
3200	359	719
4000	374	749
5000	400	1000
6000	②	②

① For lower than maximum load currents, watt loss may be estimated by reducing the full load loss by the following:

$$W_L = (I_L/I_{FL})^2 W_{FL}$$

Where:

W_L = Load watts

W_F = Full load watts

I_L = Actual load current

I_{FL} = Full load current

② Contact Eaton.

Table 17. Estimated heat loss (watts) per structure ①

Loss is based on fully loaded vertical and cross bus rating in a structure as given below.

Rating	Vertical bus	Cross bus
2000	410	288
3200	1623	1163
4000	1097	1169
5000	1410	886
6000	②	1265
8000	—	②
10,000	—	②

① For lower than maximum load currents, watt loss may be estimated by reducing the full load loss by the following:

$$W_L = (I_L/I_{FL})^2 W_{FL}$$

Where:

W_L = Load watts

W_F = Full load watts

I_L = Actual load current

I_{FL} = Full load current

② Contact Eaton.

Table 18. Magnum DS indoor switchgear structure approximate weights (less breakers)

Structure type inches (mm)	Structure depth in inches (mm)					
	60 (1524.0)	66 (1676.4)	72 (1828.8)	78 (1981.2)	84 (2133.6)	90 (2286.0)
22 (558.8) (Breaker structure)	1250 (568)	1300 (590)	1350 (613)	1400 (636)	1450 (658)	1500 (681)
30 (762.0) (Breaker structure)	1700 (772)	1770 (804)	1840 (835)	1900 (863)	1980 (899)	2050 (931)
44 (1117.6) (Breaker structure)	2500 (1135)	2600 (1180)	2700 (1226)	2800 (1271)	2900 (1317)	3000 (1362)
22 (558.8) (Auxiliary structure)	950 (431)	1000 (454)	1050 (477)	1100 (499)	1150 (522)	1200 (545)
12 (304.8) (Transition)	475 (216)	500 (227)	525 (238)	550 (250)	575 (261)	600 (272)
22 (558.8) (Transition)	950 (431)	1000 (454)	1050 (477)	1100 (499)	1150 (522)	1200 (545)
38 (965.2) (Utility)	1600 (726)	1625 (738)	1650 (749)	1675 (760)	1700 (772)	1725 (783)
50 (1270.0) (Utility)	1650 (749)	1675 (760)	1700 (772)	1725 (783)	1750 (795)	1775 (806)

Table 19. Magnum DS breaker weights—lb (kg) ①

Breaker	Fixed	Drawout
MDS-408	110 (50)	130 (59)
MDS-608	110 (50)	130 (59)
MDS-808	120 (55)	145 (66)
MDS-C08	120 (55)	145 (66)
MDS-616	110 (50)	130 (59)
MDS-816	120 (55)	145 (66)
MDS-C16	120 (55)	145 (66)
MDS-620	120 (55)	145 (66)
MDS-820	120 (55)	145 (66)
MDS-C20	120 (55)	145 (66)
MDS-632	135 (61)	175 (80)
MDS-832	135 (61)	175 (80)
MDS-C32	135 (61)	175 (80)
MDS-840	250 (114)	310 (141)
MDS-C40	250 (114)	310 (141)
MDS-850	250 (114)	310 (141)
MDS-C50	250 (114)	310 (141)
MDS-860	250 (114)	310 (141)
MDS-C60	250 (114)	310 (141)

① Manually or electrically operated. For approximate impact weight, add 50% of breaker weight.

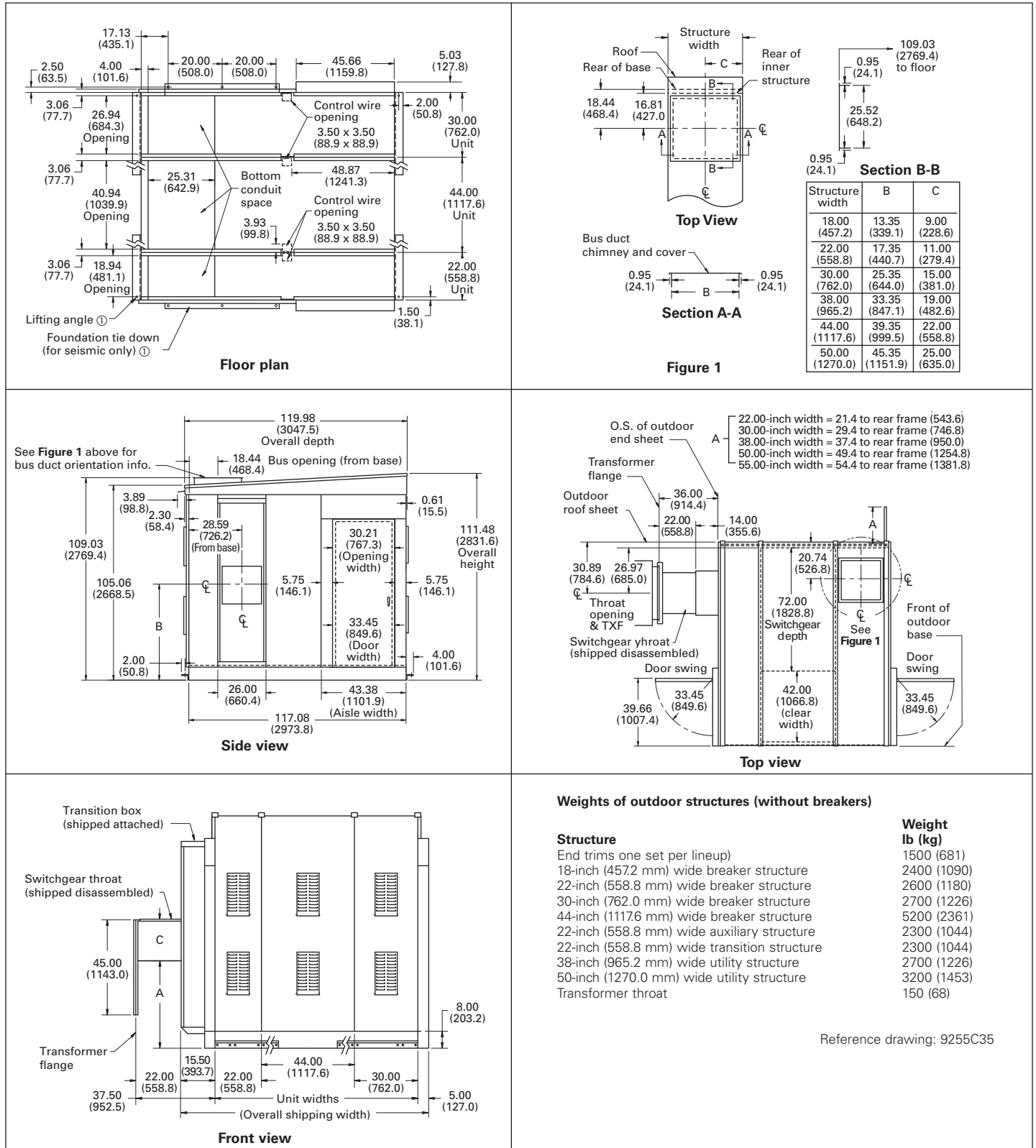

Figure 27. Outdoor walk-in enclosure—dimensions in inches (mm)

① 0.75-inch (19.1 mm) hardware recommended in all tie down locations.

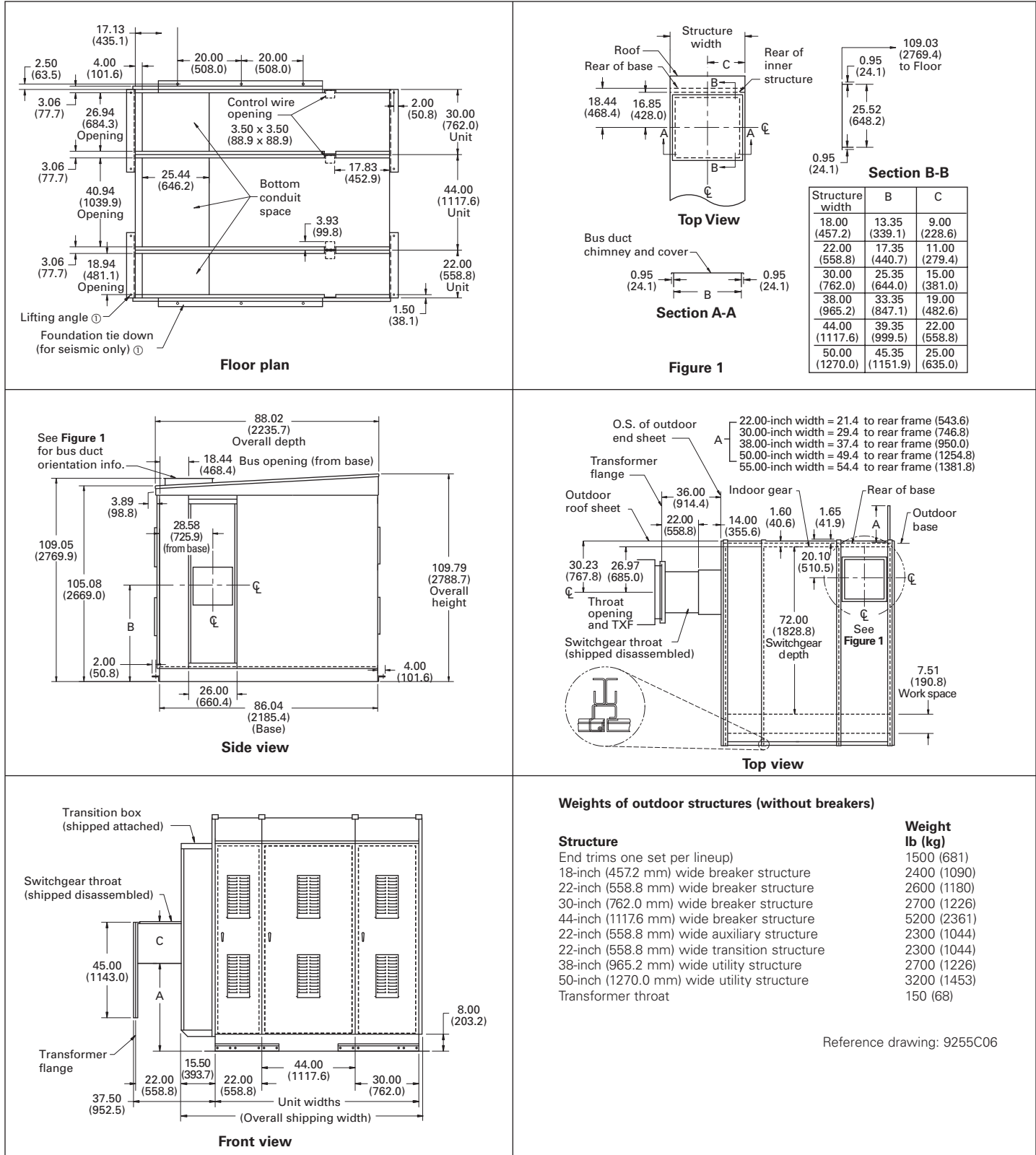

Figure 28. Outdoor non-walk-in enclosure—dimensions in inches (mm)

⓪ 0.75-inch (19.1 mm) hardware recommended in all tie down locations.

A	B	C	Centerline of copper connection from bottom of structure
41.38	51.23	19.70	55
46.63	57.00	18.70	55
52.63	63.00	18.70	61

Features

Structure

Standard finish

Gray paint finish (ANSI 61) using a modern completely automated and continuously monitored electrostatic powder coating. This continually monitored system includes spray de-grease and clean, spray rinse, iron phosphate spray coating spray rinse, non-chemical seal, oven drying, electrostatic powder spray paint coating and oven curing.

Integral base

The rugged formed base greatly increases the rigidity of the structure and reduces the possibility of damage during the installation of the equipment and is suitable for rolling, jacking and handling. A lifting angle is permanently welded into the bus compartment structure for increased strength.

Heavy-duty door hinges

Each breaker door is mounted with hinge pins. Removal of the door is easily accomplished by just lifting the hinge pin. This allows easy access to the breaker internal compartment for inspection and maintenance.

Rear cover/doors

In Magnum DS switchgear standard rear covers with captive hardware are the bolt-on type. They are split into two sections to facilitate handling during removal and installation. Optional rear doors are also available.

Through-the-door design

The following functions may be performed without the need to open the circuit breaker door: levering the breaker between positions, operate manual charging system and view the spring charge status flag, close and open breaker, view and adjust trip unit and read the breaker rating nameplate.



Through-the-door design

Front accessible

When the door is open or removed each breaker compartment provides front access to isolated, vertical wireways, primary disconnects, cell current transformers and other breaker compartment accessories for ease of field wiring and troubleshooting field connections.

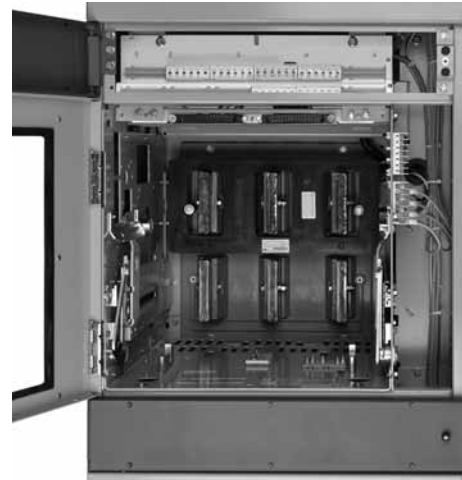

Through the door design

Four-position drawout

Breakers can be in connected, test, disconnected or removed position. The breaker compartment door can be closed in the connected, test and disconnected positions.

Closing spring automatic discharge

Mechanical interlocking automatically discharges the closing springs when the breaker is removed from its compartment.

Optional safety shutters

Positive acting safety shutters which isolate the breaker connections to the main bus when the breaker is withdrawn from the cell is an option offered for additional safety beyond our standard design. Insulating covers ("boots") are furnished on live main stationary disconnecting contacts in compartments equipped for future breakers.

Breaker inspection

When withdrawn on the rails, breaker is completely accessible for visual inspection; tilting is not necessary. The rails are permanent parts of every breaker compartment. Interference interlocks are supplied on breakers and in compartments where the compartments are of the same physical size to ensure an incorrect breaker cannot be inserted.

Key interlock (switchgear mounted)

Breaker can be stored in compartment, and completely removed for maintenance or for use as a spare without disturbing the interlock. No modification of the breaker required. This mechanism holds the breaker mechanically trip-free to prevent electrical or manual closing. An additional single cylinder breaker mounted key interlock is also available as an option.

Optional mechanical interlock

Available between adjacent breakers.

Bus

Buses and connections

Vertical and cross bus ratings in Magnum DS switchgear are based on a UL and ANSI standard temperature rise of 65 °C above a maximum ambient air temperature of 40 °C.

Bus ampacities

Vertical and cross bus ratings in Magnum DS are 2000, 3200, 4000, and 5000 A. In addition, 6000, 8000, and 10,000 A cross bus ratings are available.

Bus bracing

Unique vertical bus configuration provides an optional industry leading short circuit withstand rating of 200,000 A without the need for preceding current limiting fuses. Standard bracing is 100,000 A. The "U" shaped bar is the heart of the Magnum DS vertical bus. This configuration provides a much higher mechanical strength. To further demonstrate the strength and rigidity of this bus system, it has been verified through testing to withstand 85,000 A short circuit for a full 60 cycles.

Silver plating

Bolted, silver-plated copper main buses are standard. The plating is over the entire length of the bar, not just at the joints. Optional tin-plated copper buses are available.

Bus joints

All joints are bolted and secured with Belleville-type spring washers for maximum joint integrity. These washers reduce the potential of joint hardware loosening during the change of joint temperature associated with variations of the loads.

Full neutral

For four-wire applications, the neutral bus is rated 100% of main bus rating as a standard, up to a maximum ampere rating of 6000 A.

Ground

A ground bus is furnished the full length of the switchgear assembly and is fitted with terminals for purchaser's connections.

Glass reinforced polyester and Ultramid® stand-off insulation system

Glass reinforced polyester has been used on both low- and medium-voltage switchgear for decades. By combining this industry proven material with Ultramid insulation, a total system providing exceptional mechanical and dielectric withstand strength, as well as high resistance to heat, flame, and moisture, is produced. Substantial testing to demonstrate accelerated effects of heating and cooling on the mechanical and dielectric properties of this system prove it to provide superior performance for decades of trouble-free operation.

Optional conductor insulation covering

For applications requiring additional bus protection in harsh environments, Magnum DS switchgear is designed for the addition of optional conductor insulation covering, in addition to providing full UL air clearance without insulation. This material is applied during the assembly of the bus and covers all vertical and horizontal phase busbars. Removable boots provide access to section-to-section bus joints for inspection and maintenance purposes.

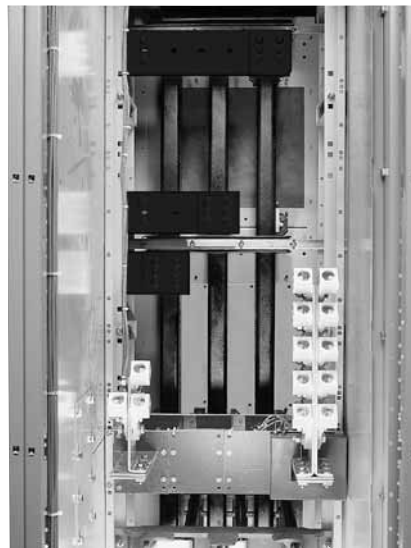

Optional insulated bus

Barriers

Optional grounded metal barriers isolate the main bus and connections from the cable compartment providing added safety to the workers while reducing the potential of objects falling into the bus compartment.

Wiring

Cable Compartment

The cable compartment gives ample room for terminating the power cables. Removable top roof sheets allow for easy conduit hub installation. The floor of the cable compartment is open to allow cable entry from underground duct banks. Optional floor plates are available.

Optional grounded metal barriers isolate the main bus and connections from the cable compartment, as well as optional barriers to separate adjacent cable compartments.

In addition to cable, Pow-R-Way busway and nonsegregated bus duct can be terminated in the compartment.

Lug pad

The lugs are located on the breaker run-backs to accommodate lug orientations at a 45° angle to reduce the bending radius of the cable needed for making the connections, thus reducing installation and maintenance time. Mechanical setscrew type lugs are standard. Optional NEMA 2-hole compression lugs are available as an option.

Control wireway

An isolated vertical wireway is provided for routing of factory and field wiring in each switchgear section. Breaker secondary terminal blocks are mounted as standard above each circuit breaker. The terminal blocks are rated 30 A and will accept bare wire, ring or spade terminals for wire size ranges of #22 to #10. Extruded loops are punched in side sheets of the vertical wireway to allow securing of customer control wiring without the use of adhesive wire anchors.

For applications involving excessive wiring, or nonstandard terminal blocks, terminal blocks are mounted on the rear frame with the power cables where they are readily accessible for customer's connections and inspection.

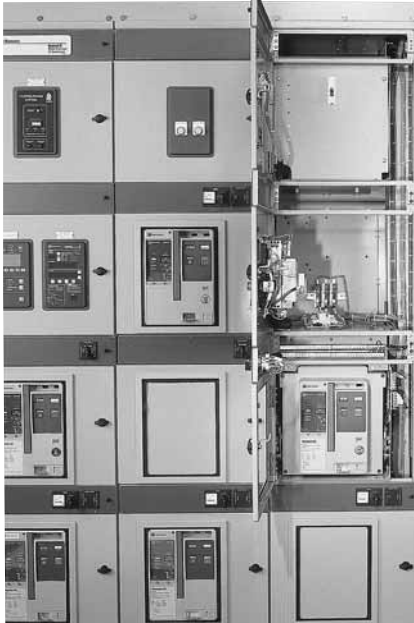

Control wireway

Control wire

Standard wire is Type SIS insulated stranded copper, extra flexible No. 16 AWG minimum.

Control wire marking

Each wire is imprinted with ink cured under ultraviolet light for durability and for easy identification by the user. The enhanced solvent resistance and durability of the aerospace grade UV cure ink has been tested for severe environments. The imprinting is made periodically along the length of the wire, with the ends being imprinted more frequently. The point of origin, wire designation and point of destination are imprinted in the following format: <origin zone/wire name/destination zone>. Each device has a uniquely designated zone. "<" indicates the direction of the wire origination and ">" indicates the direction of the wire destination. As an option, wire marking can be made utilizing sleeve type or heat shrink sleeve type.



Control wire marking

Secondary terminal compartment door

The customer's secondary terminal connections are located behind a separate door providing access to these connections without the need to open the breaker compartment door.

Short circuiting terminal blocks

One provided for each set of instrumentation or relaying application current transformers.

Shipping split connection

At each shipping split, the control connections are made with plug-in terminal blocks rated 600 V, 40 A. The terminal blocks interlock mechanically without removing the line or load connections. This method of making the shipping split control connections increases the speed of installation and reduces the potential of incorrect connections.

Instrumentation/metering

Flexibility

Magnum DS switchgear allows for a variety of metering options:

- Analog switchboard type meters such as ammeters, voltmeters, watthour, power factor, etc.
- Electronic power metering such as the IQ family of analyzer, DP-4000, etc.
- Instrument door mounted meters. For feeder circuit instrumentation, 2% accuracy ammeters and ammeter switches can be mounted on the secondary contact compartment door between the breaker compartment doors. The ammeters and switches are immediately associated with definite breaker circuits. Other devices, such as control pushbuttons, breaker control switches, indicating lights, and test switches can be mounted on these panels, within space limitations.

Voltage transformers

Voltage transformers are rated 10 kV BIL and are protected by both primary and secondary fuses. The primary fuses are of the current limiting type.

Current transformers

Current Transformers for metering and instrumentation are mounted in the breaker compartments and are front accessible. Secondary wiring between the current transformer and the standard shorting terminal block is color-coded for ease of identification.

Control power transformers

Control transformers are provided when required for AC control of circuit breakers, space heaters, and/or transformer fans. Like voltage transformers, they are protected by current limiting primary fuses. Non-current limiting fuses are used on the secondary side to protect branch circuits.

Instrumentation—door mounted

Secondary terminal compartment door

Devices, such as control pushbuttons, breaker control switches, indicating lights, and test switches can be mounted on these panels, within space limitations. The ammeters and switches are immediately associated with definite breaker circuits.

Instrument compartment door

Devices, such as electronic power metering and analog switchboard type meters that do not fit on the secondary terminal compartment door, are mounted on the instrument compartment door or on the panel of a blank cell.



Devices mounted on secondary terminal compartment door



Devices mounted on instrument compartment door

Accessories and options

Switchgear accessories

Standard accessories furnished with each Magnum DS switchgear assembly include:

- One breaker levering crank
- Insulating covers or “boots” are furnished on live main stationary disconnecting contacts in compartments equipped for future breakers
- Removable cover to block opening in the door when the breaker is temporarily removed from its compartment

Optional accessories

- Traveling type circuit breaker lifter, rail-mounted on top of switchgear
- Floor running portable circuit breaker lifter and transfer truck with manual lifting mechanism. This requires approximate 84-inch (2134 mm) deep front aisle space
- Test cabinet for electrically operated breakers, with pushbuttons, control cable and receptacle, for separate mounting
- Portable test kit for secondary injection testing and verification of trip units. Utilizes standard 120 V, 15 A, single-phase, 60 Hz supply, available from any outlet
- Additional removable cover to block opening in the door when breaker is temporarily removed from its compartment
- Removable insulating boots over power cable lug adapters



Optional switchgear mounted lifter

Breaker

Contacts

The Magnum DS has silver tungsten moving contacts and silver graphite stationary contacts. The contacts provide a long-wearing, low-resistance joint. The contacts are protected from arcing damage even after repeated interruptions by the “heel-toe” action which causes the integral arcing contacts to mate before the main contacts part. The arcing contacts then part last, striking the arc away from the main contacts.

The main contacts are of the butt type and are composed of a multiplicity of fingers to give many points of contact without alignment being critical.



Magnum DS breaker contacts (arc chutes removed)

Stored-energy mechanism

A cam-type closing mechanism closes the breaker. It receives its energy from a spring that can be charged by a manual handle on the front of the breaker or by a universal electric motor.

Release of the stored energy is accomplished by manually depressing a button on the front of the breaker or electrically energizing a releasing solenoid.

Arc chute

There are three basic means of extinguishing an arc: lengthening the arc path; cooling by gas blast or contraction; deionizing or physically removing the conduction particles from the arc path.

The DE-ION® principle is incorporated in all Magnum DS circuit breakers. This makes possible faster arc extinction for a given contact travel, ensures positive interruption and minimum contact burning.

Levering mechanism

The worm gear levering mechanism is self-contained on the breaker drawout element and engages slots in the breaker compartment. A removable crank is used to lever the breaker between the connected, test and disconnected positions.

Mechanical interlocking is arranged so that levering cannot be accomplished unless the breaker is in the opened position.

Protection during levering operation

When levering the breaker between the connected, test and disconnected positions, the operator is protected from contact with live parts by the breaker door.



Levering Magnum DS breaker

True two-step stored energy closing

Refers to the sequence required to charge and close the breaker.

1. The breaker closing springs are charged either through the manual-charging handle or by the optional charging motor. The breaker is mechanically interlocked to prevent closing of the breaker until the closing springs are fully charged.
2. With the closing springs fully charged, the breaker can then be closed by pressing the manual close pushbutton on the breaker, or by the optional spring release coil through a remote electrical signal.

This means that the energy required to open the breaker is always prestored following a closing operation.

“Stored energy” is energy held in waiting, ready to open or close the breaker within five cycles or less. The unique cam and spring design provides necessary energy for a single close-open sequence as well as the energy for multiple charge-close operations such as this possible sequence: charge-close-rechargeopen-close-open.

The closing springs are interlocked with the breaker racking mechanism to insure the closing springs are discharged before the breaker can be removed from the compartment.

Manually operated breakers

Manually operated breakers are equipped with a manual charging handle to charge the closing springs. Manual closing and tripping pushbuttons are utilized to operate the breaker. Remote closing and tripping can be accomplished by installing optional electric spring release and shunt trip coils (see for available control voltages, currents and motor-operated spring charging times). The breaker closing springs must be charged manually, then remote closing and tripping signals can be sent to the breaker.

Electrically operated breakers

Electrically operated breakers are equipped with a spring charging motor and electrically operated spring release and shunt trip coils (see for available control voltages, currents and motor-operated spring charging times). The breaker manual charging handle can be used to charge the closing springs when power is not available to the charging motor.

Provisions for padlocking

All breakers include provision for padlocking open to prevent electrical or manual closing. This padlocking can secure the breaker in the connected, test or disconnected position by preventing levering of the breaker.

Ease of inspection and maintenance

Magnum DS breakers are designed for maximum accessibility and the utmost ease of inspection and maintenance.

Magnum DS switchgear—trip units

Digitrip RMS trip unit

The Digitrip RMS trip units feature a dependent curve that is depicted in the nameplate by a blue shaded area of the trip curve. The dependent curve affords better protection flexibility. Additionally, all of the trip units have, as standard, thermal memory, 50/60 Hz operation, and thermal self-protection at 90 °C.

Also, the 520M trip units have a large display window and 2% metering accuracy.

Digitrip RMS integral microprocessor-based breaker overcurrent trip systems

Provides maximum reliability with true rms sensing as standard, gives excellent repeatability, and requires minimum maintenance. No external control source is required for its protective functions.

Trip functions

Magnum DS trip units provide the maximum in flexibility and are available in the following configurations: LSI, LSIG, LSIA (ground fault alarm only). In each case, either the short delay or instantaneous (not both) functions may be defeated. This reduces the need for spare breaker inventories and provides maximum utilization of interchangeable breakers.

Change in trip rating

The overcurrent trip pickup range is established by a combination of trip unit rating plugs and matching current sensor ratings on the breaker.

Optional breaker attachments and accessories

- A. Shunt trip on manually operated breakers, for any standard control voltage.
- B. Auxiliary contacts on manually or electrically operated breakers. Maximum of 6 normally open and 6 normally closed contacts (5 normally closed contacts on electrically operated breakers) are available on any breaker, manually or electrically operated. The contact rating is 10 A.
- C. Compartment position switch, 4 or 8 (Form C) contacts, actuated by movement of drawout breaker from the connected position. Most common uses are for disconnecting remote control circuits of electrically operated breaker, and for bypassing “b” interlocking auxiliary contacts when breaker is withdrawn from the connected position.
- D. Undervoltage trip (AC and DC available). Acts to trip the breaker when the coil voltage is insufficient to restrain a spring-loaded core. The dropout point is within 30 to 60 percent of the nominal coil voltage and is not adjustable.
- E. Overcurrent trip switch (OTS). A latching type switch with two independent Form C contacts. Operates only when the trip unit trips the breaker. It may be used for alarm and/or interlocking circuits. Resetting is done by a pushbutton on the breaker faceplate.
- F. Electric close on manually operated breakers, for any standard control voltage. Breaker can be closed by remote control switch or pushbutton after the closing spring is manually charged.
- G. Operation counter.
- H. Breaker mounted key interlock.
- I. Second shunt trip coil in place of UVR coil.

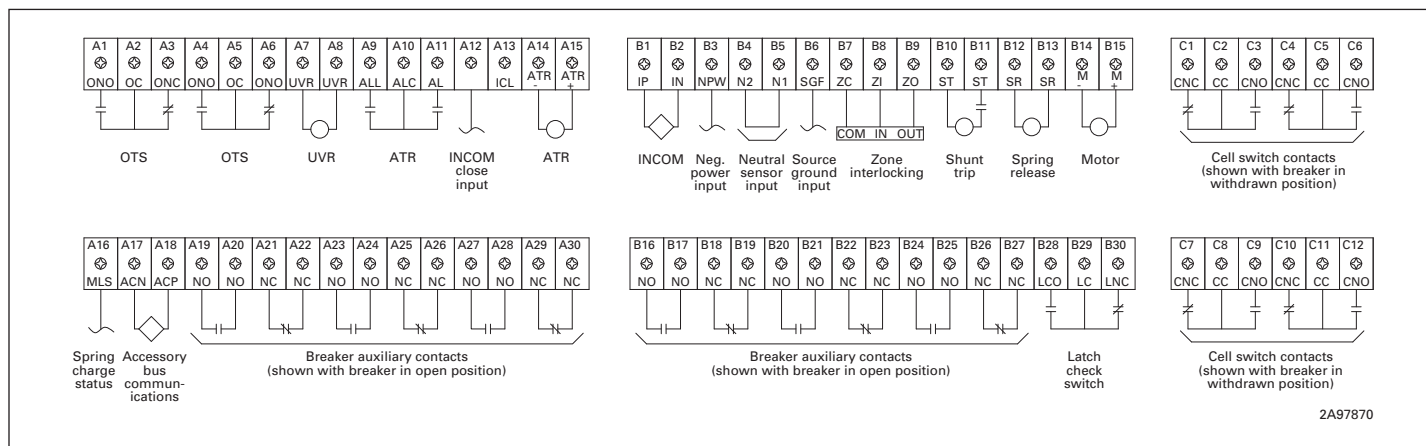

Figure 29. Magnum DS switchgear cell secondary contact configuration

Typical specifications

General

Magnum DS indoor low-voltage metal-enclosed switchgear shall consist of a stationary structure assembly and one or more removable Magnum DS power circuit breakers complete with disconnecting devices and other necessary accessories. The switchgear shall be suitable for 600 V maximum service and shall withstand a 2200 Vac dielectric test in accordance with ANSI standards. It shall be designed, manufactured and tested in accordance with the latest applicable standards of IEEE, NEMA, ANSI, UL and CSA. Documentation of design testing shall be third-party certified.

Stationary structure

Each steel unit forming part of the stationary assembly shall be a self-contained housing having one or more individual breaker or instrument compartments, and a rear compartment for the buses and outgoing cable connections.

Prying slots shall be provided on the base of the structures for ease of positioning in equipment rooms.

A rigid integral steel base shall be provided for each section, which will allow movement of shipping groups directly on rollers without the need for a separate skid.

Each circuit breaker compartment shall be equipped with primary and secondary contacts, drawout extension rails, stationary levering mechanism parts, and required instrument current transformers. A formed steel door, supported on concealed hinges with removable pins, shall be provided for each circuit breaker compartment. Access to the integral circuit breaker control panel, including the trip unit, shall be provided without the need to open the breaker compartment door. Closed-door spring charging and levering operations shall also be accomplished without the need to open the breaker compartment door.

The top of the unit shall be enclosed with removable steel sheets, which include necessary hooded ventilation openings. A separate removable access panel shall be provided for drilling of control conduit hubs. A metal wireway with removable covers shall be provided for shipping-split wiring. Pull-apart type terminal blocks shall also be provided for rapid, error-free, shipping split assembly. A metal-enclosed vertical wireway shall be provided for routing of field installed control wiring.

The structure shall be so designed that future additions may readily be made at any time. The steel structure shall be thoroughly cleaned and phosphatized prior to the application of the ANSI No. 61 finish.

A white, laminated, plastic engraved circuit designation nameplate shall be provided on each circuit breaker door.

Buses and connections

Each breaker circuit shall include the necessary three-phase copper bus and connections between the source bus and one set of circuit breaker studs. NEMA 2-hole cable lugs, attached to silver-plated copper extensions for the outgoing cables, shall be provided on the other set of circuit breaker studs. The buses and connections shall consist of high-conductivity (silver-plated) (tin-plated) copper bar mounted on heavy-duty supports, and having bolted joints. All bolted bus joints shall utilize Belleville type spring washers to maintain maximum joint integrity through continuous thermal cycling. The bus system shall be suitable for applications on power systems requiring a (100) (150) (200) kA short circuit withstand rating without upstream current limiting fuses.

Terminal blocks with integral-type barriers shall be provided for circuit breaker secondary circuits. The terminal blocks shall be front accessible through a hinged access panel above each circuit breaker.

All control wiring shall be securely fastened to the switchgear assembly without the use of adhesive wire anchors. A dedicated wiring path shall be provided for purchaser's installed control wiring. Non-adhesive anchors shall also be provided for anchoring of purchaser's installed wiring.

Disconnecting devices

The stationary part of the primary disconnecting devices for each circuit breaker shall consist of a set of contacts extending through a glass polyester insulating base. Buses and outgoing cable terminals shall be directly connected to them. The corresponding moving contacts shall consist of a set of contact fingers suitably spaced on the circuit breaker studs. For ease of inspection and maintenance, contact fingers shall not be a permanent part of the stationary structure. In the "connected" position, these contacts shall form a current-carrying bridge. The assembly shall provide a multitude of silver-to-silver high-pressure point contacts. High uniform pressure on each finger shall be maintained by springs. The entire assembly shall be full floating and shall provide ample flexibility between the stationary and moving elements. Contact engagement shall be maintained only in the "connected" position.

The secondary disconnecting devices shall consist of floating fingers mounted on the stationary unit and automatically engages contacts located at the front of the compartment. The secondary disconnecting contacts shall be silver-plated to ensure permanence of contact. Contact engagement shall be maintained in the "connected" and "test" positions.

Removable element

The removable element shall consist of a Magnum DS power circuit breaker equipped with the necessary disconnecting contacts and interlocks for drawout application. The removable element shall have four position features and shall permit closing the compartment door with the breaker in the "connected," "test," and "disconnected" positions.

Power circuit breakers

The circuit breaker shall be Magnum DS, operating on the DE-ION arc interruption principle. These breakers shall incorporate specially designed circuit-interrupting devices that provide high interrupting efficiency and minimize the formation of arc flame and gases.

The primary contacts shall have an easily accessible wear indicator to indicate main contact erosion. The breaker closing time shall be no more than three cycles. Each breaker shall have three windows in the front cover to offer clear indication of trip and close electrical accessories mounted in the breaker. The breaker shall be equipped with "DE-ION" arc chutes which effectively enclose the arcing contacts and confine the arc to reduce the disturbance caused by short-circuit interruption. Each breaker shall be equipped with a position indicator, mechanically connected to the circuit breaker mechanism.

Each breaker shall be equipped with a microprocessor-based, true rms sensing trip device. The adjustments shall be:

- Long delay pickup between 40% and 100% of the trip rating
- Long delay time between 2 and 24 seconds at 6 times trip rating
- Short delay pickup between 2 and 10 times long delay trip setting, short delay time between 0.1 and 0.5 seconds at 2.5 times short delay pickup. Short delay protection shall be defeatable, but only if instantaneous protection is activated. Both “flat” and “I²t” protection shall be provided. (Optional) Zone selective interlocking trip units and necessary wiring within the switchgear shall be provided for each breaker indicated on the drawings
- Instantaneous pickup between 2 and 12 times trip rating. Instantaneous protection shall be defeatable, but only if short delay protection is activated
- (Optional) Ground fault pickup approximately 25% of sensor rating, and ground fault time between 0.1 and 0.5 seconds. Both “flat” and “I²t” protection shall be provided. Pickup shall not exceed 1200 A, regardless of circuit breaker maximum continuous rating. Ground fault shall be field selectable for residual, zero sequence or source ground protection. Selectability shall be made in the circuit breaker compartment, not on the drawout element, to maximize the flexibility of interchangeable drawout power circuit breakers. (Optional) Zone selective interlocking trip units and necessary wiring within the switchgear shall be provided for each breaker indicated on the drawings

It shall be possible to test and verify the time and current characteristics and trip circuit by means of a portable plug-in test device.

Both electrically operated and manually operated breakers shall have stored energy operating mechanisms. The device to close the breaker shall be by means of a mechanical pushbutton, which insures positive control of the closing operation.

Seismic

The switchgear assembly and circuit breakers shall be suitable for and certified to meet all applicable seismic requirements of (UBC) (The California Building Code) for Zone 4 application. Guidelines for the installation, consistent with these requirements, shall be provided by the switchgear manufacturer and be based upon actual testing of representative equipment. The test response spectrum shall be based upon a 5% minimum damping factor, (Insert the following for UBC: a peak of 0.75g, and a ZPA of 0.38g), (insert the following for CBC: a peak of 1.8g, and a ZPA of 0.45g). The tests shall fully envelop this response spectrum for all equipment natural frequencies up to at least 35 Hz.

Factory assembly and tests

The switchgear shall be completely assembled, wired, adjusted and tested at the factory. After assembly, the complete switchgear control and instrumentation circuits shall be tested for operation under simulated service conditions to ensure the accuracy of the wiring and the functioning of the equipment.

The main circuits shall be given a dielectric test of 2200 V for one minute between live parts and ground and between opposite polarities. The wiring and control circuits shall be given a dielectric test of 1500 V for one minute, or 1800 V for one second, between live parts and ground.

Note: Arrangement sketch and single line diagram should accompany the written specification.

Eaton
1000 Eaton Boulevard
Cleveland, OH 44122
United States
Eaton.com

© 2017 Eaton
All Rights Reserved
Printed in USA
Publication No. TD01901001E / Z20126
November 2017