

# Instructions for Magnum DS<sup>®</sup> Metal-Enclosed Low-Voltage NEMA 3R Assemblies



## Contents

Description	Page
1. Introduction . . . . .	2
2. Receiving, Handling, and Storage . . . . .	4
3. Equipment Description . . . . .	5
4. Installation . . . . .	11
5. Inspection, Testing, and Maintenance . . . . .	14
6. Document References . . . . .	14



*Powering Business Worldwide*

Read and understand these instructions before attempting to unpack, assemble, operate or maintain this type equipment.

---

## NOTICE

---

**ALL POSSIBLE CONTINGENCIES WHICH MAY ARISE DURING INSTALLATION, OPERATION OR MAINTENANCE, AND ALL DETAILS AND VARIATIONS OF THIS EQUIPMENT DO NOT PURPORT TO BE COVERED BY THESE INSTRUCTIONS.**

---

If further information is desired by purchaser regarding the particular installation, operation or maintenance of particular equipment, contact the local Eaton representative.

---

## ⚠ WARNING

---

**METAL-ENCLOSED LOW-VOLTAGE NEMA 3R ASSEMBLIES COVERED BY THESE INSTRUCTIONS ARE DESIGNED AND TESTED TO OPERATE WITHIN THEIR NAMEPLATE RATINGS. OPERATION OUTSIDE OF THESE RATINGS MAY CAUSE THE EQUIPMENT TO FAIL RESULTING IN DEATH, SERIOUS INJURY AND/OR PROPERTY DAMAGE. ALL RESPONSIBLE PERSONNEL SHOULD LOCATE THE EQUIPMENT RATING NAMEPLATE AND BE FAMILIAR WITH THE INFORMATION PROVIDED THEREON.**

---

### Purpose

This instruction manual is expressly intended to cover the installation, operation and maintenance of Magnum DS® Metal-Enclosed Low-Voltage NEMA 3R Assemblies used with Magnum DS® Power Circuit Breakers or CM52 Network Protectors.

---

## NOTICE

---

**THIS INSTRUCTION MANUAL IS INTENDED TO EMPHASIZE THE FEATURES AND ENHANCEMENTS UNIQUE TO MAGNUM DS NEMA 3R SWITCHGEAR AND SWITCHBOARDS. IT IS NOT INTENDED TO BE A COMPLETE MANUAL FOR THE INSTALLATION, OPERATION AND MAINTENANCE OF MAGNUM DS METAL-ENCLOSED LOW-VOLTAGE ASSEMBLIES, BUT IS SUPPLEMENTAL IN NATURE; AND APPENDS THE ORIGINAL ONLY AS DESCRIBED HEREIN. FOR COMPLETE INSTRUCTIONS CONCERNING MAGNUM DS METAL-ENCLOSED LOW-VOLTAGE ASSEMBLIES, SEE IB01901001E.**

---

For application information consult applicable descriptive bulletins, application publications and/or the applicable industry standards. For installation, operation and maintenance of Low-Voltage Power Circuit Breakers see separate instruction book listed in Section 6.

### Safety

All safety codes, safety standards and/or regulations MUST be strictly observed in the installation, operation and maintenance of this equipment.

---

## ⚠ DANGER

---

**THE DANGER, WARNING AND CAUTION MESSAGES INCLUDED AS PART OF THE PROCEDURAL STEPS IN THIS MANUAL ARE FOR PERSONNEL SAFETY AND PROTECTION OF EQUIPMENT FROM DAMAGE. AN EXAMPLE OF A TYPICAL WARNING LABEL HEADING IS SHOWN ABOVE THIS PARAGRAPH TO FAMILIARIZE PERSONNEL WITH THE TYPE OF PRESENTATION. THIS WILL HELP TO ASSURE THAT PERSONNEL ARE ALERT TO THESE MESSAGES. IN ADDITION, THESE MESSAGES ARE ALL UPPER CASE AND BOLDFACE.**

---

## Section 1: Introduction

### 1.1 General Information

Magnum DS Metal-Enclosed Low-Voltage NEMA 3R Switchgear and Switchboard Assemblies are uniquely designed for use in outdoor environments or other harsh conditions. The NEMA 3R Enclosure is a "skin" or "shell" that contains and protects the standard indoor assembly from the elements associated with outdoor installations, such as falling rain, sleet or snow. Therefore, most features and options inherent to the standard indoor enclosure are available in the NEMA 3R version, as well. These assemblies are tested to the rigors of UL 50E and certified as a NEMA Type 3R enclosure.

These assemblies contain the same distribution options as standard indoor assemblies and may use Magnum DS, Magnum SB and/or Series NRX® Power Circuit Breakers to control and protect power circuits up to and including 600 volts AC and interrupting capacities up to and including 200kA.

The switchgear or switchboard assembly is composed of vertical sections that are arranged to suit the customer's layout requirements. Magnum DS switchgear and switchboards utilize a four-cell high structure design consisting of various combinations of Magnum DS, Magnum SB and/or Series NRX Power Circuit Breakers and auxiliary compartments (See IB01901001E referenced in Section 6). Bus and cable compartments provide space for connections, maintenance and inspection. Power cable connections are rear-accessible as a standard, or may be front-accessible as an option.

Access to the circuit breakers is available via a walk-in design (42" aisle-way) as a standard, or a non-walk-in design (aisle-less) as an option.

This instruction manual contains important procedures and information pertinent to the receiving, handling, storage, installation, operation and maintenance of Magnum DS Low-Voltage Metal-Enclosed NEMA 3R Assemblies.

---

## NOTICE

---

**INFORMATION PROVIDED IN THIS INSTRUCTION MANUAL AND BY OTHER SUPPLIED DOCUMENTATION AND/OR DRAWINGS SHOULD BE READ AND UNDERSTOOD BY ALL PERSONNEL RESPONSIBLE FOR SUPERVISION, OPERATION OR MAINTENANCE. FAMILIARIZATION SHOULD ALWAYS INCLUDE THE CHARACTERISTICS OF EACH PIECE OF EQUIPMENT CONTAINED IN OR MOUNTED ON THE ASSEMBLY.**

**PROPER INSTALLATION, OPERATION AND MAINTENANCE ARE ESSENTIAL TO ASSURE CONTINUED SATISFACTORY SERVICE FROM THE EQUIPMENT. IT SHOULD NOT BE INSTALLED IN PLACES WHERE IT WILL BE REQUIRED TO OPERATE AT VOLTAGE, CURRENTS OR FAULT CAPACITIES GREATER THAN THOSE FOR WHICH IT WAS DESIGNED, OR WHERE THE ENVIRONMENTAL CONDITIONS ARE DIRTY, CORROSIVE, HUMID OR OTHERWISE HARSH OR UNSUITABLE. (REF. ANSI C37.20.1 FOR ABNORMAL OPERATION CONDITIONS). THE INFORMATION GIVEN IN THIS MANUAL APPLIES TO NEMA 3R LOW-VOLTAGE ASSEMBLIES UTILIZING THE MAGNUM DS FAMILY OF DRAWOUT POWER CIRCUIT BREAKERS UNLESS OTHERWISE NOTED. FOR OTHER OPTIONS, SEE THE DOCUMENTS LISTED IN SECTION 6.**

---

## 1.2 Safety Features

Each Magnum DS Assembly is manufactured with built-in interlocks and safety-related features. They are provided to reduce hazards to operating personnel and provide proper operating sequences.

---

### **⚠ DANGER**

**METAL-ENCLOSED LOW-VOLTAGE ASSEMBLIES ARE PROVIDED WITH MANY SAFETY FEATURES. NEVERTHELESS, WHEN CONNECTED THEY CONTAIN POWER CIRCUITS WITH HIGH FAULT CAPACITY. THE VOLTAGES AND POWER LEVELS AVAILABLE IN THIS EQUIPMENT MAKE CONTACT WITH BARE CONDUCTORS OR TERMINALS EXTREMELY DANGEROUS, AND IS LIKELY TO BE FATAL. ALL POWER SHOULD BE TURNED OFF OR APPROPRIATE PROTECTIVE EQUIPMENT USED WHEN WORKING ON SUCH EQUIPMENT. IN ADDITION TO THE HAZARDS INHERENT TO THE LOW-VOLTAGE ASSEMBLY ITSELF, OPERATION BY UNQUALIFIED PERSONS MAY CAUSE INDIRECT DAMAGE TO CONNECTED EQUIPMENT AND INJURY TO OPERATORS OF CONNECTED EQUIPMENT**

**UNDER NO CIRCUMSTANCE SHOULD THE INTERLOCKS OR OTHER SAFETY FEATURES BE MADE INOPERATIVE OR DISABLED, AS THIS MAY RESULT IN DEATH, BODILY INJURY OR PROPERTY DAMAGE.**

**TO PROTECT PERSONNEL DURING THE INSTALLATION, OPERATION AND MAINTENANCE OF THIS, THE FOLLOWING PRACTICES MUST BE FOLLOWED:**

## 1.3 Safety Practices

---

### **⚠ WARNING**

**MAGNUM DS LOW-VOLTAGE SWITCHGEAR AND SWITCHBOARD ASSEMBLIES ARE COMPLEX, HIGH CURRENT ELECTRICAL EQUIPMENT DESIGNED TO OPERATE WITHIN THE VOLTAGE AND CURRENT LIMITATIONS SHOWN ON THEIR RESPECTIVE NAMEPLATES. DO NOT APPLY THIS EQUIPMENT TO SYSTEMS WITH VOLTAGES AND/OR CURRENTS IN EXCESS OF THESE LIMITS.**

1. Only qualified electrical personnel familiar with the construction and operation of this equipment and the associated hazards should be permitted to work on such equipment. Additionally, only qualified personnel should be permitted to install or operate such equipment.
2. Always be certain that the primary and secondary circuits are de-energized before attempting any maintenance
3. For maximum safety, only insert a completely assembled breaker into an energized cell. Front covers are safety features and must be in place when energized.
4. While in the assembly, always ensure that drawout circuit breakers are in one of three intended positions: "Connect," "Test" or "Disconnect." A circuit breaker permitted to remain in an intermediate position could result in control circuits being improperly connected causing other equipment to malfunction
5. Do not remove access covers unless the circuits to be exposed are de-energized.
6. Use calibrated test equipment of known reliability to confirm that all circuits are de-energized before servicing
7. After maintenance, be certain every current transformer secondary circuit is completely connected or shorted.

---

### **⚠ DANGER**

**IF THE SECONDARY CIRCUIT OF ANY CURRENT TRANSFORMER IS LEFT OPEN WITHOUT LOAD, AND ITS PRIMARY CIRCUIT IS ENERGIZED, A DANGEROUSLY HIGH VOLTAGE IS DEVELOPED ACROSS TRANSFORMER SECONDARY TERMINALS. TO PREVENT DEATH, BODILY INJURY OR ELECTRICAL SHOCK, EITHER DE-ENERGIZE THE CIRCUIT BY OPENING THE BREAKER, OR SHORT CIRCUIT CURRENT TRANSFORMER SECONDARY TERMINALS, BEFORE ENERGIZING THE CIRCUIT AND PROCEEDING WITH MAINTENANCE.**

8. Always be certain that all assembly hardware is in place and bolted tightly before inserting a drawout circuit breaker into its compartment.

---

### **⚠ WARNING**

**FAILURE TO FOLLOW THESE DIRECTIONS MAY RESULT IN DEATH, SERIOUS BODILY INJURY OR PROPERTY DAMAGE.**

## 1.4 Qualified Personnel

For the purpose of operating switchgear and switchboard assemblies, a person who has been thoroughly trained in the operation of circuit breakers and any included instrumentation and who has complete knowledge of the loads connected to the assembly may be considered to be a qualified person.

For the purpose of installing, inspecting and maintaining switchgear and switchboard assemblies, a qualified person **MUST** also be a qualified electrician, who is thoroughly trained in regard to recognizing and avoiding the hazards inherent to working with electricity and in the proper way to perform such work. The individual must be able to de-energize, clear and lockout/tagout circuits in accordance with established safety practices. In addition, the individual must be equipped with, and trained in the use of, Personal Protective Equipment (PPE) (rubber gloves, arc-flash clothes, etc.) for those occasions when it is not possible to de-energize all circuits before doing maintenance work in the area.

## 1.5 Precautions

1. If relays are included, remove all blocking. Check control circuits (except voltage and current transformer circuits) for grounds and short circuits before applying control power.
2. Connect the assembly to the station ground before applying any power
3. In case of fire, do not use liquid fire extinguisher until all circuits have been disconnected.
4. If an assembly is to be stored for an extended period prior to installation, provisions must be made for energizing the space heaters to prevent condensation of moisture inside the assembly.

## 1.6 Other Publications and Documentation

In addition to this instruction manual, other printed information and documentation is supplied with each assembly. This additional information will include, but not necessarily be limited to, a Magnum DS Low-Voltage Power Circuit Breaker instruction manual, arrangement drawings, and connection diagrams. For additional references see Section 6.

## Section 2: Receiving, Handling & Storage

### NOTICE

**FOR COMPLETE RECEIVING, HANDLING AND STORAGE INSTRUCTIONS, SEE SECTION 2 OF THE PRIMARY INSTRUCTION BOOK IB01901001E, REFERENCED ELSEWHERE IN THIS PUBLICATION. INSTRUCTIONS WHICH FOLLOW EMPHASIZE THE UNIQUE FEATURES ASSOCIATED WITH MAGNUM DS LOW-VOLTAGE NEMA 3R ASSEMBLIES.**

#### 2.1 General Information

Magnum DS Metal-Enclosed Low-Voltage assemblies are shipped in one or more shipping groups, depending on the number of vertical sections, or the limitations of handling facilities at the installation site. This could typically result in three or four sections for a complete assembly. Maximum length of a preassembled NEMA 3R shipping section is 108" (2743 mm) including a transformer connection throat, if applicable.

All shipping sections are shipped so as to be protected from the weather during shipment but are not suitable for storage outdoors as shipped. NEMA 3R assemblies are not weatherproof until completely assembled. Treat them the same as indoor equipment until fully assembled.

#### 2.2 Receiving

When a Magnum DS Low-Voltage assembly reaches its destination, the purchaser should check the material received against the shipping list to be certain that all items have arrived. Note accurately any discrepancies. Each shipping group is plainly marked with or accompanied by an identifying shop order number, general order number and shipping weight. Each shipment includes a contents list which is a part of the overall package of shipping papers. To avoid the loss of any parts, the contents of each container should be carefully checked against the packing list. Do not discard any packing material until it is certain that every item has been received in the proper condition and that certain packing material will not be required later for equipment storage. Larger items, such as portable traveling lifters, are shipped in separate cartons. Other loose and unmounted items may be packed in additional cartons. These items, such as shipping split hardware, should be logged in and set aside in a safe location until the assembly has been set in its final position.

Equipment shipped from the factory is carefully packed and inspected prior to its departure. On occasion, however, equipment damage is incurred during transportation. If any damage is found, file a damage claim immediately with the transportation carrier and notify an Eaton representative. All claims should be filed as soon as possible and include applicable part numbers, shop order numbers and/or general order numbers

#### 2.3 Precautions

It is preferable to use an overhead crane when moving the assembly. Circumstances at the installation location may prevent the use of an overhead crane for all movement. In such instances, the careful use of rollers can be employed. Although the methods for moving NEMA 1 and NEMA 3R assemblies are similar, the techniques vary slightly. The differences are highlighted in this section.

##### 2.3.1 Overhead Lifting

### ⚠ WARNING

**FAILURE TO FOLLOW LIFTING INSTRUCTIONS MAY RESULT IN DEATH OR SERIOUS BODILY INJURY. READ INSTRUCTIONS FOR LIFTING SWITCHGEAR PRIOR TO ATTACHING CABLES, CHAINS OR SPREADER BARS.**

Lifting plates are attached along the assembly base at the front and rear for crane cable attachment. Suitably sized spreader bars (not provided) must be placed between lift cables to prevent equipment damage (Figure 1). If it appears that the cables will touch the assembly during the lifting process, place appropriately sized lumber along the sides where contact could be made between the cable and the equipment. This will prevent damage caused by the lifting cables.



Figure 1. NEMA 3R Assembly Lifting Method.

### 2.3.2 Rolling

If during the moving and positioning process it is not feasible to use an overhead crane, the equipment can be moved on construction rollers. The heavy steel base on an NEMA 3R assembly is suitable for use directly when rolling. Use no less than four evenly spaced rollers for assembly movement. Since equipment length can vary, each 1.5 to 2.0 feet (457 to 610 mm) of equipment length requires a roller. As the equipment is carefully moved, the rollers that become free at the end opposite the movement direction should once again be placed at the front for continued movement.

### 2.3.3 Lifting Plate Removal

The lifting plates attached at the base perform the dual purpose of providing a convenient and robust method of securing the unit to the foundation. A separate channel base is not required. Once an assembly is in its permanent location remove the lifting eyes from the angles (Figure 2). Rotate the angles 180 degrees and reinstall. Use the holes in the angles to bolt the assembly to the foundation.



**Figure 2. Figure 2 Lifting Angle in Place As Received Prior to Reversing for Securing to Foundation.**

### 2.4 Storage

A fully assembled assembly requires a minimum of care during outdoor storage. The area should be reasonably free of dirt and corrosive gases. The space heaters, which are standard with weatherproof assemblies, must be energized to prevent condensation. NEMA 3R assemblies which are not fully assembled must be treated in the same manner as indoor equipment.

---

#### **⚠ CAUTION**

**WHEN SPACE HEATERS ARE ENENERGIZED, CARE MUST BE TAKEN THAT INTEGRAL CONTROL POWER TRANSFORMERS ARE NOT BACK-FED. DISCONNECT PRIMARY AND SECONDARY FUSES.**

---

During storage, all assemblies, whether indoors or outdoors, should be placed on a firm, level surface. This will prevent any unnecessary strain or possible distortion. Store all other separately packaged accessory equipment in a clean, dry location. It is recommended that a waterproof cover be placed over circuit breaker cartons and the cartons kept in an indoor storage location when the circuit breakers are stored separately from the assembly.

## Section 3: Equipment Description

### 3.1 General Description

The following descriptions apply to standard metal-enclosed construction and wiring. Special features and control schemes are often incorporated per customer specifications. These special features are evident and portrayed on the drawings and diagrams for the specific assembly. Instructions on included apparatus such as relays, instruments, control switches and circuit breakers are included elsewhere in separate instruction books or sheets.

Each low-voltage (600 volts and below) indoor and outdoor metal-enclosed assembly is factory assembled and tested. It is designed to require a minimum amount of labor for installation.

Each metal-enclosed assembly consists of a stationary structure that includes one or more free-standing vertical sections mechanically and electrically joined to make a single coordinated installation.

In enclosures identified as rear-accessible, a vertical section consists of three major divisions: the front compartment (breakers), bus compartment, and cable compartment, wherein the power cables are accessed through doors located in the rear of the enclosure. In addition, personnel ingress (and access to the circuit breakers) is affected either through a walk-in aisleway (Figure 3) or directly through the front of the enclosure (Figure 4).

In enclosures identified as front-accessible, the three divisions are redistributed between a pair of vertical sections: front compartment/bus compartment in one half; cable compartment/bus compartment in the remaining half, wherein the power cables are accessed through doors located in the front of the enclosure. In addition, personnel ingress (and access to the circuit breakers) is affected either through a walk-in aisleway (Figure 5) or directly through the front of the enclosure (Figure 6).

All Magnum DS Metal-Enclosed Low-Voltage NEMA 3R Assemblies are a predetermined depth based on one of the four configurations chosen. Direct transformer connections are easily managed with rear-accessible units. However, due to the foreshortened design of front-accessible assemblies, direct transformer connection is not possible without the aid of a special transition enclosure. If this is an essential part of an installation, contact an Eaton sales and service representative for assistance.

---

#### **NOTICE**

**FOR SPECIFIC INFORMATION REGARDING THE INTERNAL CONSTRUCTION OF MAGNUM DS METAL-ENCLOSED LOW-VOLTAGE ASSEMBLIES, INCLUDING BUT NOT LIMITED TO CIRCUIT BREAKER INSTALLATION, BUS CONSTRUCTION AND CABLE/CONDUIT SPACES, REFER TO SECTION 3 OF IB01901001E, REFERENCED IN SECTION 6 OF THIS MANUAL.**

---



### 3.2 NEMA 3R Enclosure Construction Options (Figures 3 - 6)

Magnum DS Metal-Enclosed Low-Voltage NEMA 3R Assemblies are offered in four varieties to meet the limitations of space and customer preferences. The options include location of power cable connections as well as presence or absence of a personnel ingress aisle-way.

#### 3.2.1 Rear-Access with Aisle-way

Power cable connections are accessible from the rear of the assembly. The rear access doors are hinged and provided with door stops. These braces keep the doors open at a 90 degree angle. Power cables and conduits can exit through the floor or through the roof if the proper roof-exit flange is installed (by customer order request). Connection to line and/or load breaker connections is the same as described in IB01901001E, the indoor assembly literature for rear-accessible enclosures.

A front operating and maintenance aisle extends through all units of the assembly. A large reinforced door with panic hardware is standard at each end of the aisle. These doors can be opened from the inside, even when padlocked from the outside.

The structure also includes, as standard, filtered ventilation openings (filters can be changed without opening aisle or rear compartment doors), aisle lighting, GFI protected convenience receptacles and space heaters. When specified, a thermostat is mounted in the cable compartment. Space heaters are located in the "D" position breaker cell, bus compartment and cable compartment of each vertical section.

#### 3.2.2 Rear-Access without Aisle-way (Non walk-in)

Power cable connections are the same as described above. Connection to line and/or load breaker connections is the same as described in IB01901001E, the indoor assembly literature for rear-accessible enclosures.

The front aisle-way is absent in the non-walk-in design, permitting an assembly depth reduction of approximately 32 inches (812 mm) over the standard rear-access walk-in assembly. Access to the breaker compartment is affected through full-height doors on the front of the enclosure. These doors contain the same bracing features present on the rear doors described above. Ventilated filters, lighting, receptacles and heaters are standard as described above.

The work space between the external shell and the internal breaker enclosure is approximately 7.5 inches (190 mm), therefore the need for a means of emergency exit is not provided.

**Note:** A unique feature of the non-walk-in assembly is the internal breaker doors hinge on the right-hand side as normal convention, rather than the left.

#### 3.2.3 Front-Access with Aisle-way

Front accessible assemblies provide further footprint reductions when required by customer installations.

Power cable connections are accessible from the front of the assembly through the maintenance aisle-way as described below. Power cables and conduits can exit through the floor or through the roof if the proper roof-exit flange is installed (by customer order request). Connection to line and/or load breaker connections is the same as described in IB01901001E, the indoor assembly literature for front-accessible enclosures.

A front operating and maintenance aisle extends through all units of the assembly. A large reinforced door with panic hardware is standard at each end of the aisle. These doors can be opened from the inside, even when padlocked from the outside.

The structure also includes, as standard, filtered ventilation openings (filters can be changed without opening aisle or rear compartment doors), aisle lighting, GFI protected convenience receptacles and space heaters. When specified, a thermostat is mounted in the cable compartment. Space heaters are located in the "D" position breaker cell, bus compartment and cable compartment of each vertical section.

#### 3.2.4 Front-Access without Aisle-way (Non walk-in)

Power cable connections are the same as described above. Connection to line and/or load breaker connections is the same as described in IB01901001E, the indoor assembly literature for front-accessible enclosures.

The front aisle-way is absent in the non-walk-in design, permitting an assembly depth reduction of approximately 31 inches (784 mm) over the standard front-access walk-in assembly. Access to the breaker compartment and power cable connections is affected through full-height doors on the front of the enclosure. These doors contain the same bracing features present on the rear doors described above. Ventilated filters, lighting, receptacles and heaters are standard as described above.

The work space between the external shell and the internal breaker enclosure is approximately 7.5 inches (190 mm), therefore the need for a means of emergency exit is not provided.

**Note:** A unique feature of the non-walk-in assembly is the internal breaker doors hinge on the right-hand side as normal convention, rather than the left.

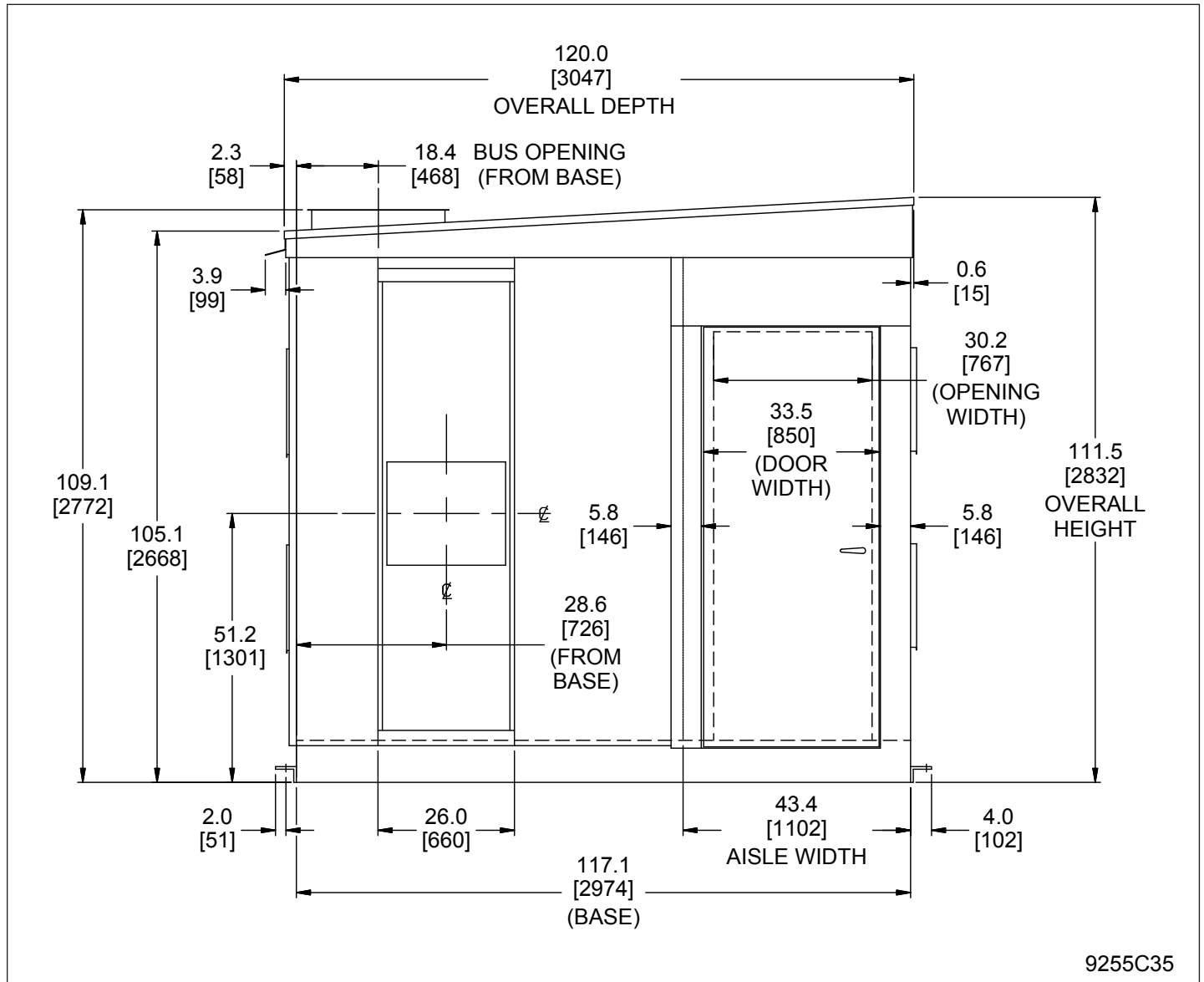

Figure 3. Side Elevation NEMA 3R Assembly Rear-Accessible with Walk-in Aisle Way.

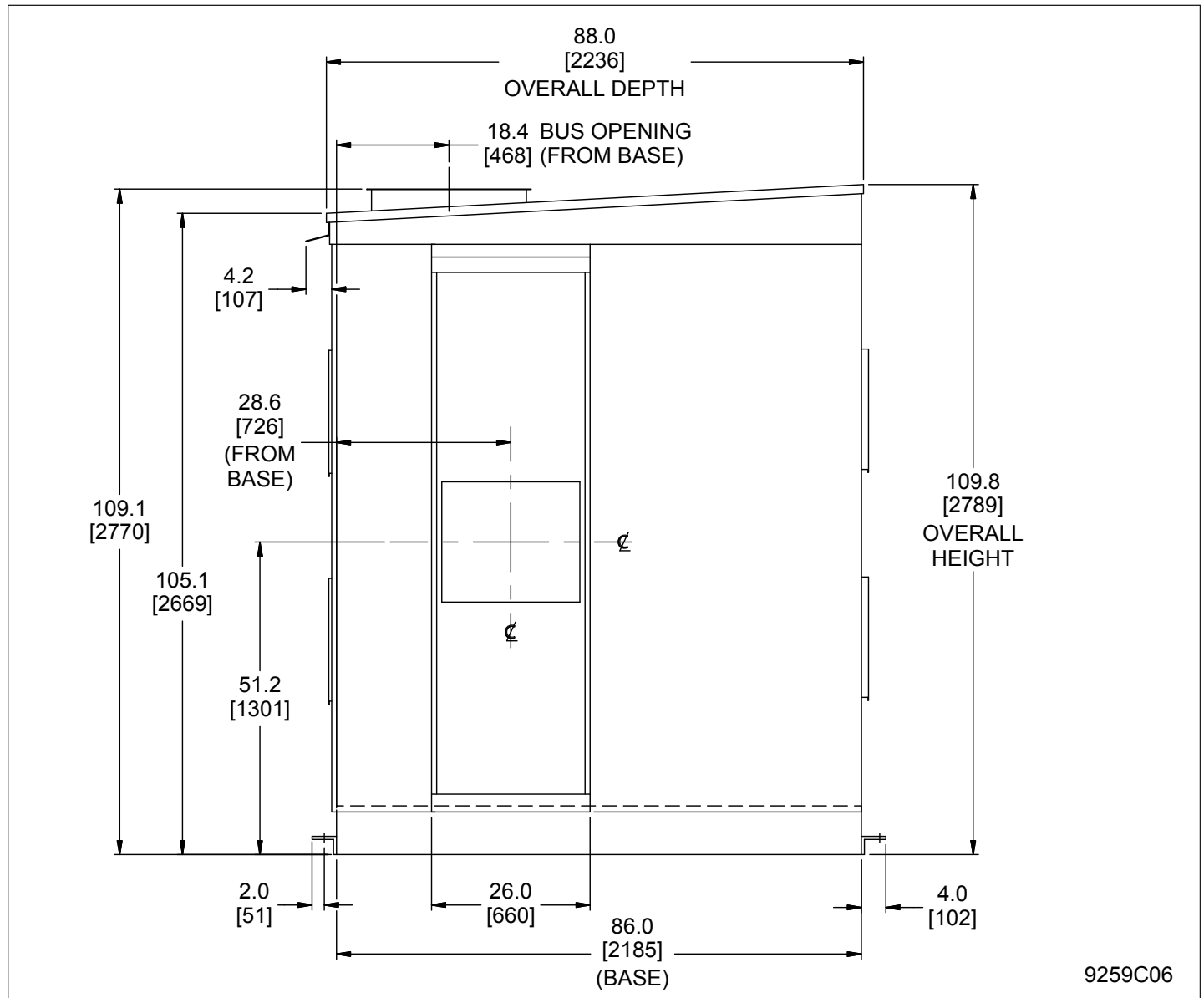

Figure 4. Side Elevation NEMA 3R Assembly Rear-Accessible without Walk-in Aisle Way.



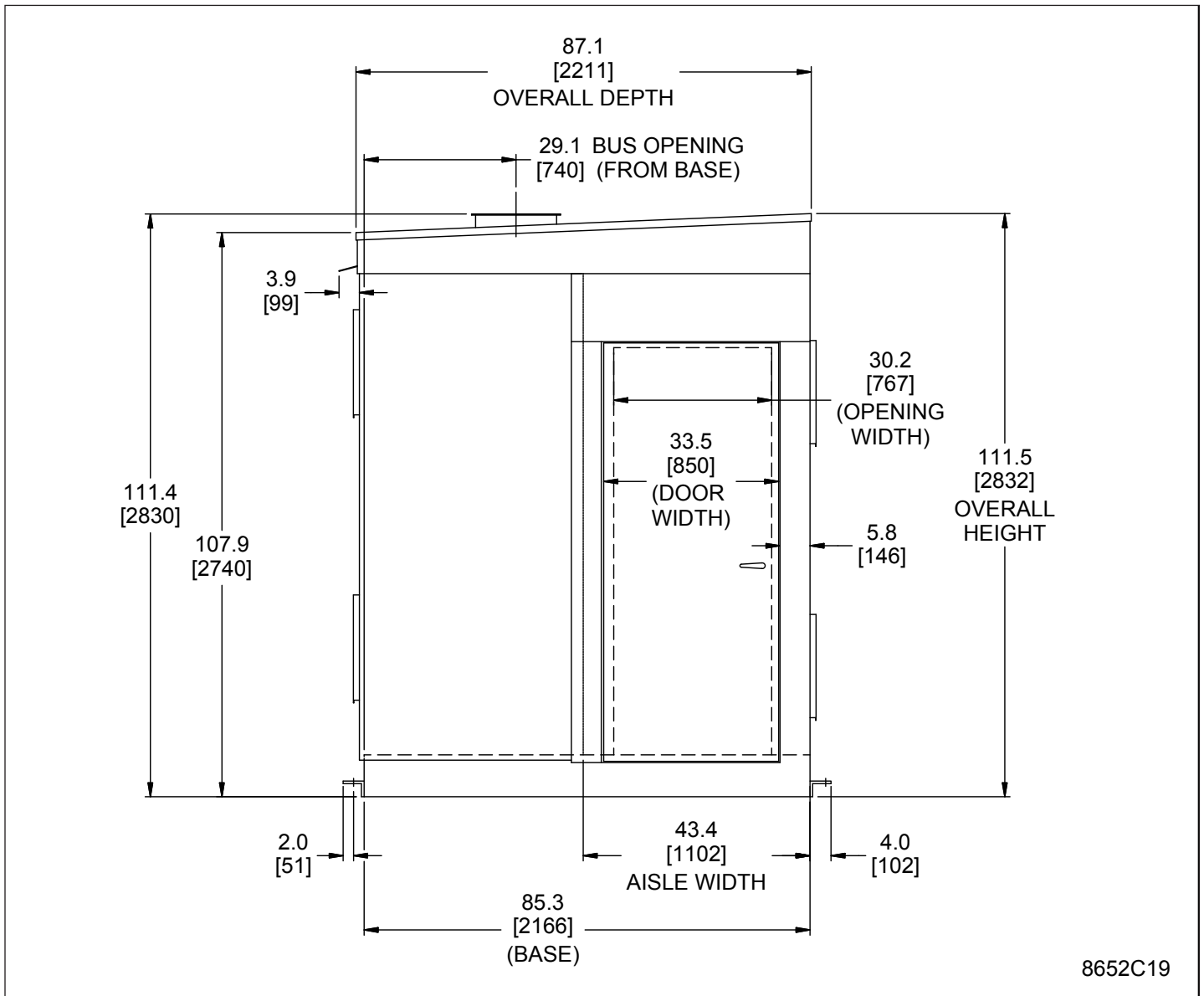

Figure 5. Side Elevation NEMA 3R Assembly Front-Accessible with Walk-In Aisle Way.

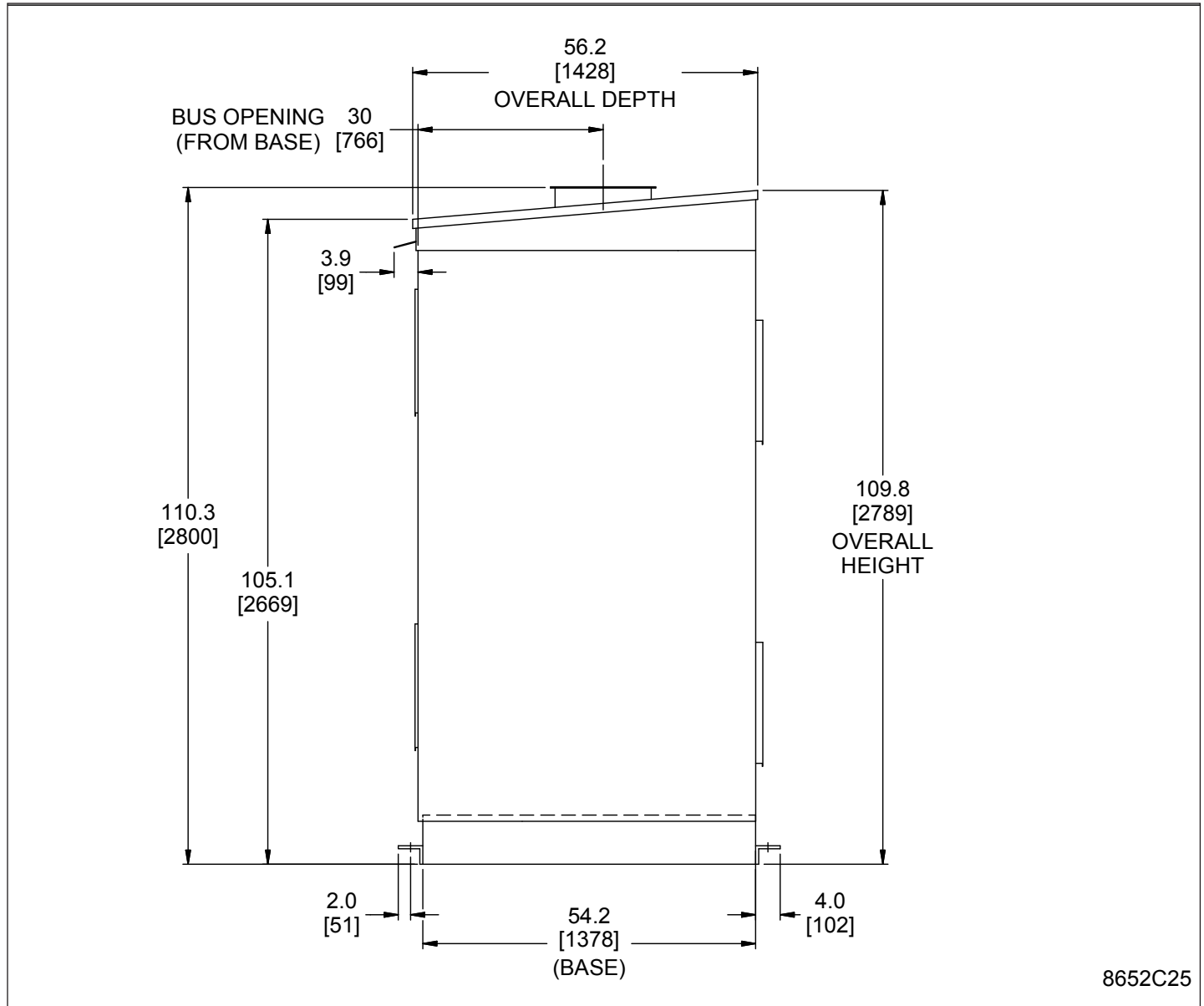

Figure 6. Side Elevation NEMA 3R Assembly Front-Accessible without Walk-In Aisle Way.

## Section 4: Installation

### **⚠WARNING**

**BEFORE PROCEEDING WITH ANY INSTALLATION, TESTING, START-UP OR MAINTENANCE, REVIEW ALL OF SECTION 1 FOR SAFETY PRACTICES AND RECOMMENDATIONS. FAILURE TO DO SO MAY RESULT IN DEATH, SERIOUS BODILY INJURY OR PROPERTY DAMAGE.**

#### 4.1 General Information

This section contains instructions for installing Magnum DS Metal-Enclosed Low-Voltage Assemblies. Proper installation of Magnum DS Metal-Enclosed Low-Voltage Assemblies is of prime importance. Too much emphasis cannot be placed on this phase of the work. Study the associated instruction manuals and drawings carefully.

### **⚠CAUTION**

**PERSONNEL INSTALLING THIS EQUIPMENT MUST BE THOROUGHLY FAMILIAR WITH ALL ASSOCIATED INSTRUCTION MANUALS AND APPLICABLE GOVERNING CODES. ADDITIONALLY, ALL DRAWINGS, WHETHER MECHANICAL OR ELECTRICAL, MUST BE UNDERSTOOD AND STRICTLY FOLLOWED TO PREVENT POSSIBLE DAMAGE TO THE SWITCHGEAR OR EQUIPMENT BEING PROTECTED.**

#### 4.2 Location and Foundation

Magnum DS Metal-Enclosed Low-Voltage assemblies are constructed at the factory on smooth level surfaces to assure correct alignment of all parts. Extra care by the purchaser in selecting the location and preparing the foundation will result in reduced installation costs, as well as good equipment performance.

##### 4.2.1 Location

In general, the location will have been determined during the specification and/or procurement phases. Certain locations may impose requirements which must be met so that the switchgear assembly may operate efficiently with the least amount of maintenance. Consideration must be given to the open space required at the front and rear of the equipment, space at the ends of the lineup, and the characteristics of the environment.

The space at the front must be sufficient to meet applicable codes, permit the opening of doors, the insertion and withdrawal of circuit breakers, and the transfer of circuit breakers to other compartments by means of an overhead lifter or portable lifting device. In rear-accessible enclosures, the space at the rear must be sufficient to meet local codes, permit ventilation, open rear doors, install cables, inspect equipment and perform maintenance.

##### 4.2.2 Foundation

The site foundation should be smooth and level (within 1/8 inch per three feet [3.5 mm/meter] in any direction) to avoid distortion of the structure. The lifting plates attached at the base perform the dual purpose of providing a convenient and robust method of securing the unit to the foundation. A separate channel base is not required. Once the assembly is in its permanent location remove the lifting eyes from the angles (Figure 2). Rotate the angles 180 degrees and reinstall. Use the holes in the angles to bolt the assembly to the foundation. For further details see the foundation plans provided with the equipment.

#### 4.2.3 Conduits

Provisions must be made in the site foundation for all conduits entering from below. Specific floor plan details provided with the equipment must be used to determine the final conduit layout and footprint required for each lineup (See Base Plan reference drawing 4A37896).

Power conduits should project above the finished floor not more than ten inches (254 mm) for one of these assemblies. Control wire conduits should not extend higher than nine inches (228 mm). It will simplify moving the shipping section groups into place if the conduits are flush with the concrete surface and appropriate extension sleeves added after the units are in their final location. See Base Plan reference drawing 4A37896 supplied with the assembly for bottom entry conduit space and location.

#### 4.3 Shipping Section Group Assembly

Before connecting the separate shipping sections of the assembly, all components should be available at the site location. The prepared foundation should be ready and all embedded conduits installed and capped.

### **⚠CAUTION**

**PRIOR TO INSTALLATION AND ASSEMBLY, BE CERTAIN THE FOUNDATION IS LEVEL AND FREE OF ANY DEBRIS TO PREVENT EQUIPMENT DAMAGE.**

##### 4.3.1 Preparation of the Unit for Assembly

Magnum DS NEMA 3R Assemblies are shipped with external shipping braces attached to prevent distortion of the unit during transport. These braces may be a length of aluminum angle, a steel support as shown in Figure 7, or both depending upon the enclosure type. Any such brace attached is temporary and should be removed and discarded prior to connecting the shipping sections.

Roof seams are covered by a welded seam cover. These are shipped attached to the enclosure roof for convenience. Prior to joining shipping sections, remove the seam cover from any shipping section where it overhangs, similar to as shown in Figure 8. Remove the securing hardware and retain for reinstallation after the units are connected and secured per the instructions below.

Also remove any packing cardboard, including cardboard on aisle-way floors, prior to installation.



Figure 7. Temporary Shipping Brace on Walk-in Aisleway.

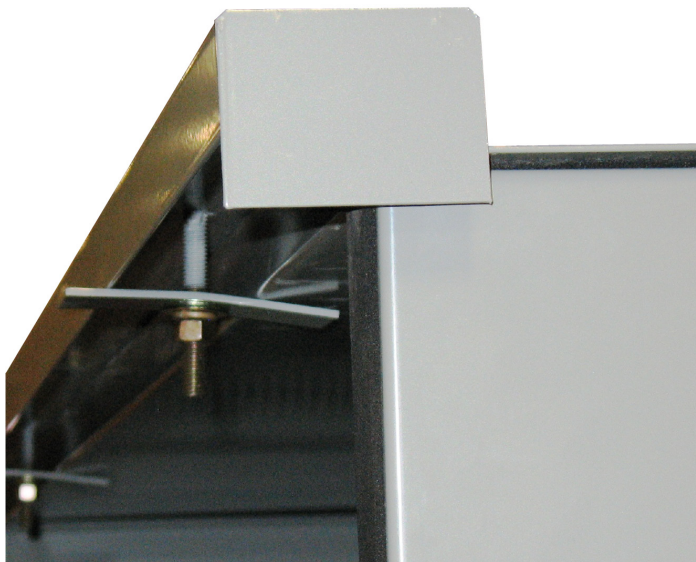

**Figure 8. Roof Seam Cover.**

#### 4.3.2 Assembly Procedures

When correctly installed, both rear and front-accessible assemblies should conform to the following requirements:

1. Front panels should form a straight line. When transformers and/or other gear are included, equipment should be located in keeping with the plan drawings supplied with the equipment.
2. Vertical sections must be correctly spaced from center to center and plumb. A suggestion for lining up the shipping groups is to establish a base line a few inches in front of the assembly and parallel to the final location. Equalize the distances from the front of the shipping groups to the base line, thus making the face of the assembly parallel to the base line. Check each vertical section by dropping a plumb line from the top corner of each vertical section. It should align with the bottom corner.
3. The entire assembly of vertical sections should be securely fastened to floor channels or base pad.
4. Shipping groups must be securely bolted together and all bus and control wiring connections properly made.

After the first shipping group has been located, the second shipping group should be moved into position and similarly checked. The shipping groups are fastened together in accordance with the instructions given in drawing 9253C18. This drawing is included in the information packet attached to the side of the switchgear assembly. Should additional copies of this drawing be needed, contact your Eaton sales office.

#### 4.4 Bus, Cable and Control Connections

Refer to Section 4.4.1 thru 4.4.6 of reference IB01901001E for complete instructions and guidelines on various bus connections, installation of power cables, and connection of control wiring.

#### 4.5 Traveling Circuit Breaker Lifter

The traveling overhead circuit breaker lifter is a standard device installed on these assemblies where an aisle-way is present. For convenience the hoist assembly is shipped contained within one of the end shipping sections of any multi-section shipping group. Remove the retaining straps securing the breaker lifter hoist prior to use. A ready-to use overhead lifter is shown in Figure 9.



**Figure 9. Overhead Circuit Breaker Lifter.**

### ⚠ DANGER

**DO NOT STAND UNDER THE CIRCUIT BREAKER DURING HOISTING OPERATIONS. THE CIRCUIT BREAKER MIGHT SLIP AND CAUSE PERSONAL INJURY. KEEP HANDS AND TOOLS AWAY FROM SPREADER BAR, LIFTING HOOKS AND BREAKER. SEVERE INJURY MAY RESULT. SUDDEN MOTIONS ARE COMMON IN A CABLE UNDER TENSION AS IT WINDS AROUND A WINCH DRUM.**

Spreader bars that attach to the traveling hoist for purposes of attaching to the circuit breaker will be shipped separately.

In assemblies where an aisle-way is not present (non-walk-in), or by customer request, a separate portable breaker lifter may be specified. Portable lifting devices are recommended to only be utilized on smooth level surfaces. See Figure 10 below.

#### 4.6 Moving Parts

There are few moving parts in the stationary structures of Magnum DS Low-Voltage Assemblies. It is recommended that all moving parts be carefully operated by hand. This will ensure that no binding or damage has occurred during shipment or handling. In some cases, accessories may be blocked or braced for shipment. Thoroughly check apparatus, such as meters and relays, for forms of blocking or bracing which must be removed.

- STEP 1** WITH BREAKER SPREADER BAR SECURELY ATTACHED TO CABLE COMING FROM LIFT, CONNECT SPREADER BAR TO BREAKER. (SEE DWG. 2A97859)
- STEP 2** HOIST BREAKER SO THAT IT'S CASSETTE RAIL SEATS ARE ABOVE THE CASSETTE RAILS OF THE APPROPRIATE BREAKER CELL. MAKE SURE FRONT OF BREAKER IS FACING OUT!
- STEP 3** POSITION LIFT CLOSE ENOUGH TO SWITCHGEAR TO ALLOW FOR BREAKER INSTALLATION INTO CELL, AND SET THE BRAKES ON THE WHEELS OF THE LIFT.
- STEP 4** SLOWLY LOWER BREAKER DOWN AND GUIDE IT ONTO THE CASSETTE RAILS, ENSURING THAT BOTH SIDES OF THE BREAKER ARE SECURELY SEATED ONTO THE CASSETTE RAILS.
- STEP 5** WITH BREAKER SAFELY POSITIONED ON CASSETTE RAILS, REMOVE ALL TENSION FROM THE CABLE ATTACHED TO SPREADER BAR. TO DISENGAGE SPREADER BAR FROM BREAKER, PUSH DOWN ON THE SIDES OF THE SPREADER BAR AND SLIDE IT TOWARDS THE REAR OF THE BREAKER. WHEN SPREADER BAR IS FREE FROM THE BREAKER, RAISE LIFT AND PULL IT AWAY FROM THE SWITCHGEAR.
- STEP 6** RETURN TO STEP 1 TO LOAD THE NEXT BREAKER.

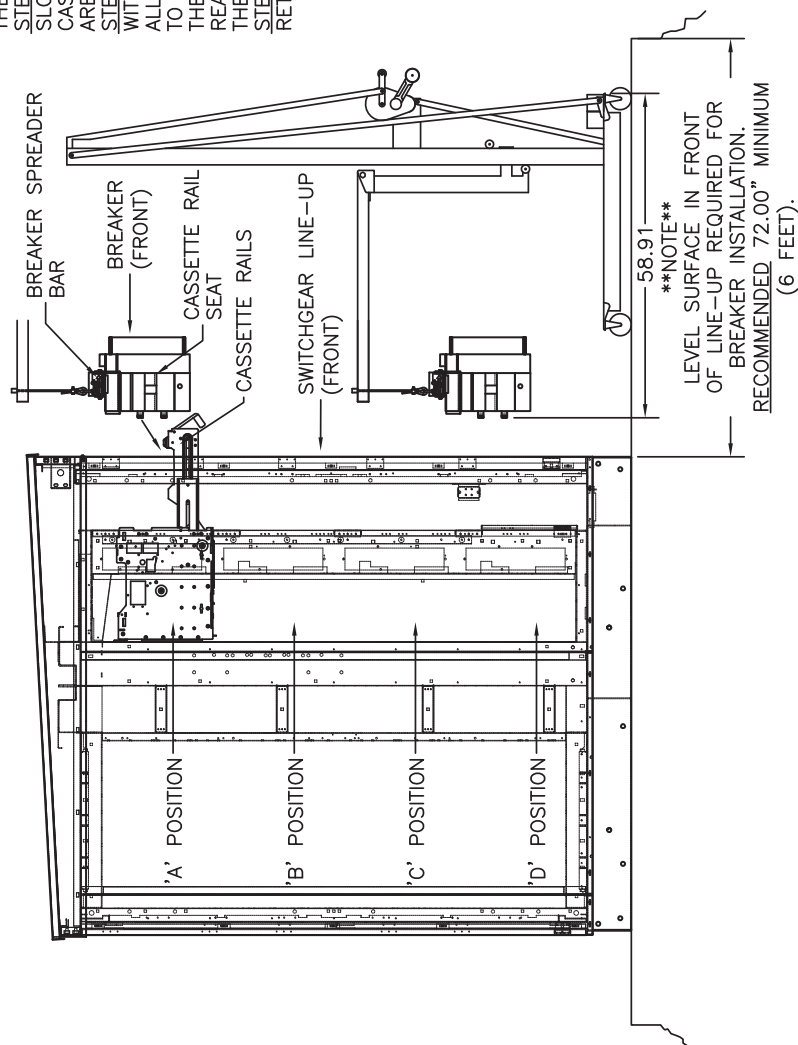

- NOTES:**
1. DIAGRAM SHOWS BREAKER BEING LOADED INTO 'A' POSITION, ALWAYS LOAD BREAKERS STARTING WITH THE BOTTOM POSITION! LOAD IN THIS ORDER: 'D', POSITION - 1st, 'C', POSITION - 2nd, 'B', POSITION - 3rd, 'A', POSITION - 4th
  2. DIAGRAM SHOWS BREAKER BEING LOADED INTO 'A' POSITION, INSTALLATION TYPICAL FOR ALL POSITIONS.
  3. TO REMOVE BREAKERS FROM CELL, REVERSE INSTALLATION PROCEDURE.

9259C08

Figure 10. Circuit Breaker Installation with Portable Breaker Lifter without Walk-in Aisle Way.



## Section 5: Inspection, Testing and Maintenance

For complete instructions regarding inspection and testing of Magnum DS switchgear and switchboards prior to start-up and operation, see Section 5 of IB01901001E. Read and follow all instructions regarding safety practices described therein.

---

### **⚠ DANGER**

---

**ENERGIZING THE SWITCHGEAR FOR THE FIRST TIME IS POTENTIALLY DANGEROUS. THEREFORE, ONLY QUALIFIED PERSONNEL SHOULD BE PRESENT WHEN THE EQUIPMENT IS ENERGIZED. IF PROBLEMS CAUSED BY DAMAGE OR POOR INSTALLATION PRACTICES HAVE NOT BEEN DETECTED IN THE CHECKOUT PROCEDURE (PREVIOUSLY DESCRIBED), DEATH, PERSONAL INJURY OR SERIOUS DAMAGE MAY RESULT WHEN POWER IS APPLIED.**

---

For instructions regarding periodic maintenance of switchgear/switchboard devices, bus and connections, as well as replacement parts, see Section 6 of IB01901001E. Read and follow all instructions regarding safety practices described therein.

---

### **⚠ DANGER**

---

**WHEN ENERGIZED, A CIRCUIT BREAKER IS PART OF A HIGH POWER SYSTEM. BEFORE ATTEMPTING ANY INSPECTION OR MAINTENANCE, BE SURE THAT ALL PRIMARY AND CONTROL CIRCUITS HAVE BEEN DE-ENERGIZED AND GROUNDED AS REQUIRED. ALSO MAKE CERTAIN THAT PROPER STEPS HAVE BEEN TAKEN TO BE SURE THAT THEY WILL REMAIN DE-ENERGIZED UNTIL ALL WORK IS COMPLETED. FAILURE TO DO SO MAY RESULT IN DEATH, BODILY INJURY OR ELECTRICAL SHOCK.**

---

## Section 6: Document References

In addition to this Instruction Book, the following Instruction Books and drawings are commonly included in any low-voltage assembly shipment. Please inspect the packet attached to the outside, or within an empty cell, for all pertinent documentation before contacting an Eaton service representative for replacements.

<b>2A97855</b>	Magnum DS Structure Section View Type DS Low-Voltage Metal-Enclosed Switchgear
<b>4A37896</b>	Magnum DS Structure Base Plan
<b>9253C18</b>	Shipping Split Bus Information
<b>9253C21</b>	Installation Space Requirements

In addition, the following documents may be included depending upon optional equipment contained within the assembly:

<b>4A37898</b>	Installation Guidelines for Users of Magnum DS Low-Voltage Rear/Front Access Switchgear Assemblies for Seismic Applications
<b>IB 2C12060H08</b>	Instructions for Installation, Operation and Maintenance of Magnum DS, DSX and DSL Low Voltage Power Circuit Breakers
<b>IB 2C12063H02</b>	Instructions for Installation, Operation and Maintenance of Magnum SB Insulated Case Low Voltage Power Circuit Breakers
<b>IB 32-693A</b>	Instructions for Field Testing of Ground Fault Systems Utilizing Eaton Magnum DS Circuit Breakers
<b>IB 32-698C</b>	Instructions for C-HRG "Safe-Ground" Low-Voltage High Resistance Pulsing Ground System
<b>IB 52-01-TE</b>	Instructions for Eaton Type CM52 Network Protectors 800 to 4500 Amperes
<b>MN01301001E</b>	Instructions for Installation, Operation and Maintenance of Series NRX Low Voltage Power (Air) Circuit Breakers

Also, supporting documentation and instructions for auxiliary components and devices contained within the assembly will be forwarded with any shipment. The accuracy of claims made within documents by other manufacturers is not the responsibility of Eaton but the device manufacturer.

There are numerous supporting documents which are not listed here due to the wide variety of components contained within any given assembly. For a full selection of available documents, see the Technical Documents section of [www.Eaton.com](http://www.Eaton.com).



**Notes:**

This Instruction Booklet is published solely for information purposes and should not be considered all-inclusive. If further information is required, you should consult an authorized Eaton sales representative.

The sale of the product shown in this literature is subject to the terms and conditions outlined in appropriate Eaton selling policies or other contractual agreement between the parties. This literature is not intended to and does not enlarge or add to any such contract. The sole source governing the rights and remedies of any purchaser of this equipment is the contract between the purchaser and Eaton.

**NO WARRANTIES, EXPRESSED OR IMPLIED, INCLUDING WARRANTIES OF FITNESS FOR A PARTICULAR PURPOSE OR MERCHANTABILITY, OR WARRANTIES ARISING FROM COURSE OF DEALING OR USAGE OF TRADE, ARE MADE REGARDING THE INFORMATION, RECOMMENDATIONS, AND DESCRIPTIONS CONTAINED HEREIN.**

In no event will Eaton be responsible to the purchaser or user in contract, in tort (including negligence), strict liability or otherwise for any special, indirect, incidental or consequential damage or loss whatsoever, including but not limited to damage or loss of use of equipment, plant or power system, cost of capital, loss of power, additional expenses in the use of existing power facilities, or claims against the purchaser or user by its customers resulting from the use of the information, recommendations and description contained herein.

**Eaton Corporation**  
Electrical Sector  
1111 Superior Ave.  
Cleveland, OH 44114  
United States  
877-ETN-CARE (877-386-2273)  
Eaton.com

© 2011 Eaton Corporation  
All Rights Reserved  
Printed in USA  
Publication No. IB01900002E / TBG000585  
June 2011