

Installation guidelines for users of Magnum DS Low-Voltage Front-Access Switchgear Assemblies for seismic applications

A representative Type Magnum DS® Low-Voltage Front-Access Switchgear Assembly was attached to a seismic table and shaken to simulate the effects of an earthquake. The test exceeded the requirements of the 2012 International Building Code (IBC), the 2013 California Building Code (CBC), and OSHPD Seismic Pre-certification (OSP). The following guidelines were developed as a result of that test program, and they apply to standard and arc-resistant switchgear:

- When Magnum DS Front-Access Switchgear is subjected to an earthquake, it pulls on its foundation. The importance of an adequate foundation cannot be over emphasized; in fact, proper mounting is the single most important factor in withstanding a seismic event. The foundation must be level and continuous under the entire switchgear assembly. The foundation must be designed to withstand the reaction loads imposed on it by the equipment. The foundation must be designed to hold a quantity of two ½-13 SAE Grade 5 bolts per section or four ½-13 SAE Grade 5 bolts per section if not mounting switchgear to a wall or six ½-13 SAE Grade 5 bolts per back-to-back section if mounting switchgear back-to-back. The anchoring system must be strong enough to prevent “pull-out” of these bolts. The wall behind the switchgear must be designed to hold a quantity of two ½-13 SAE Grade 5 bolts per section. The anchoring system must be strong enough to prevent “pull-out” of these bolts. Both anchoring systems, wall, and foundation should be put into place prior to switchgear installation to reduce effort associated with anchoring. Welding to embedded steel members is acceptable, provided the weld strength is equivalent to that of four SAE Grade 5 bolts specified. For nuclear installations, weld per AWS D1.1, alternatively, welding procedures and personnel qualifications may be performed IAW ASME BPVC Section IX and the inspections be performed IAW AWS D1.1, and/or D1.3 and/or D9.1. See foundation drawings provided for the specific project to identify anchoring locations.
- Magnum DS Front-Access Switchgear is supplied with wall braces that must be used to anchor the rear of the switchgear to a wall (see **Figure 4**).
- When Magnum DS is subjected to an earthquake, it moves. The amount of motion depends on the magnitude of the earthquake. Eaton Pow-R-Way® and non-segregated phase bus ducts, and their associated switchgear flanges have been seismically qualified as a system. If other types of top entry, i.e., conduits, are necessary, attachments must be capable of accommodating a 3-inch front-to-back and side-to-side (6 inches peak-to-peak) cabinet motion.
- Center of gravity**
For seismic calculations, the following dimensions should be used to locate the approximate center of gravity for Magnum DS switchgear. They are applicable to all types of line-ups:

Vertical	60 inches
From left-to-right	Center of line-up
From front	One-half the depth of the switchgear

Enclosure weights are found on the equipment drawings provided for the specific project. Add breaker weights to enclosure weight.
- When a switchgear assembly is separated into groups of vertical sections for shipment, the user must be sure to install all of the inter-unit tie bolts (see drawing 9253C18). Failure to join the shipping groups together properly could result in damage to the equipment during an earthquake.
- It is recommended that incoming power cables be lashed together at least every 4 feet within the switchgear.
- The drawout Magnum DS power circuit breakers should always remain in the connected position or they should be secured remote from the switchgear.
- The user should provide storage areas to secure mobile pieces of equipment (such as breaker lifting trucks, spare breakers, hand trucks, etc.) away from the switchgear so it is not damaged by being bumped during an earthquake. When the optional top-of-gear traveling circuit breaker lifter is provided, it must be secured in place with the hardware provided when not in use. Refer to the operating instructions provided with the switchgear for the details of this procedure.



Powering Business Worldwide

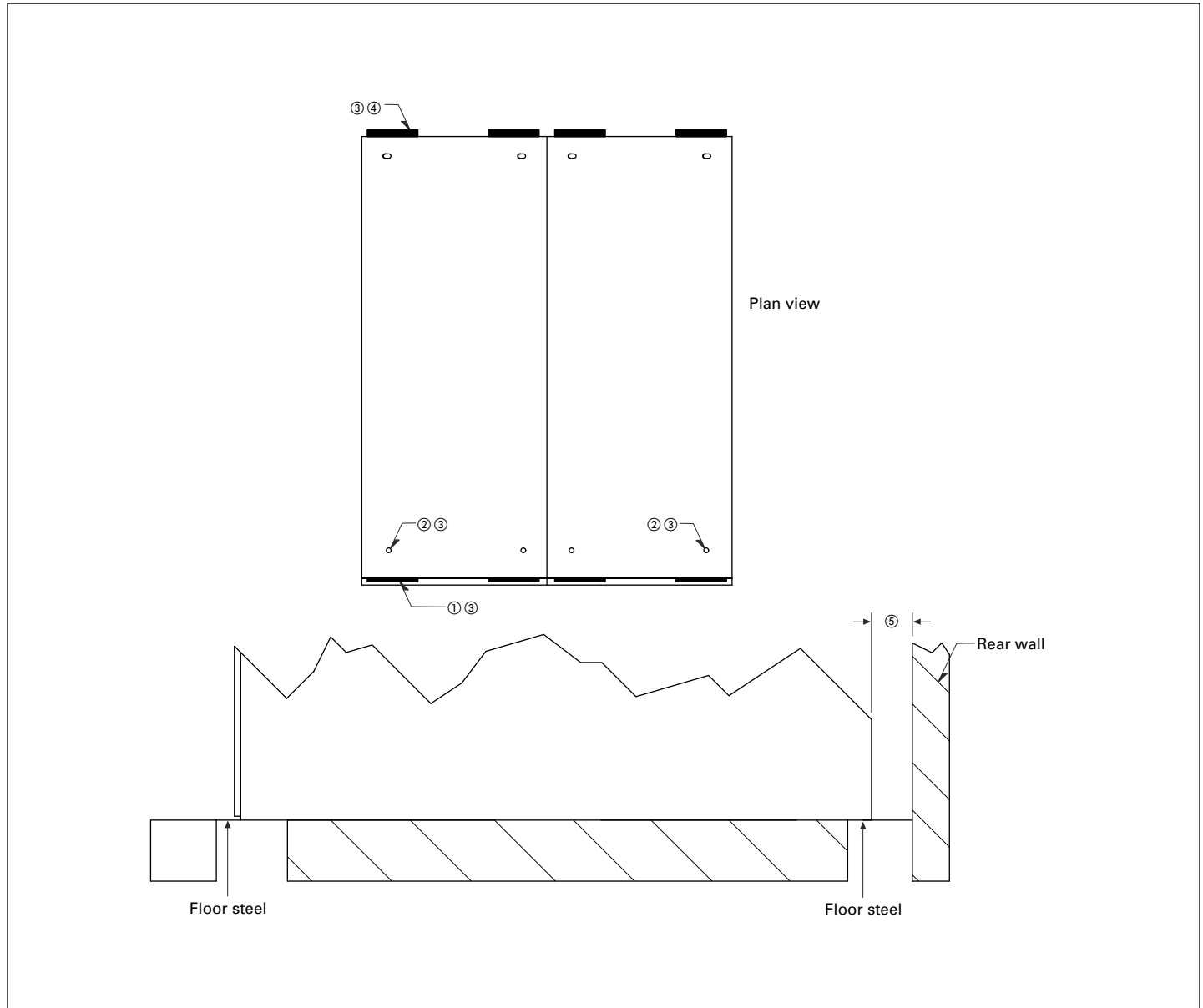

Figure 1. Welding of indoor structures to imbedded floor steel—front-access Magnum switchgear

- ① 0.19 inches (4.8 mm) weld, 4.00 inches (101.6 mm) long at two places on front of each section starting 0.50 inches (12.7 mm) from each edge of structure. See **Figure 3** for front access wall brace weld instructions.
- ② Internal bracket on each end of line up to be plug welded to floor steel.
- ③ For nuclear installations, weld per AWS D1.1, alternatively, welding procedures and personnel qualifications may be performed IAW ASME BPVC Section IX and the inspections be performed IAW AWS D1.1, and/or D1.3 and/or D9.1.
- ④ 0.19 inches (4.8 mm) weld, 4.00 inches (101.6 mm) long at two places on rear of each section starting 0.50 inches (12.7 mm) from each edge of structure if wallmount brace is not being used.
- ⑤ Sufficient clear space, between the wall and the rear of the switchgear, should be provided to allow for proper attachment of the switchgear to the pad.

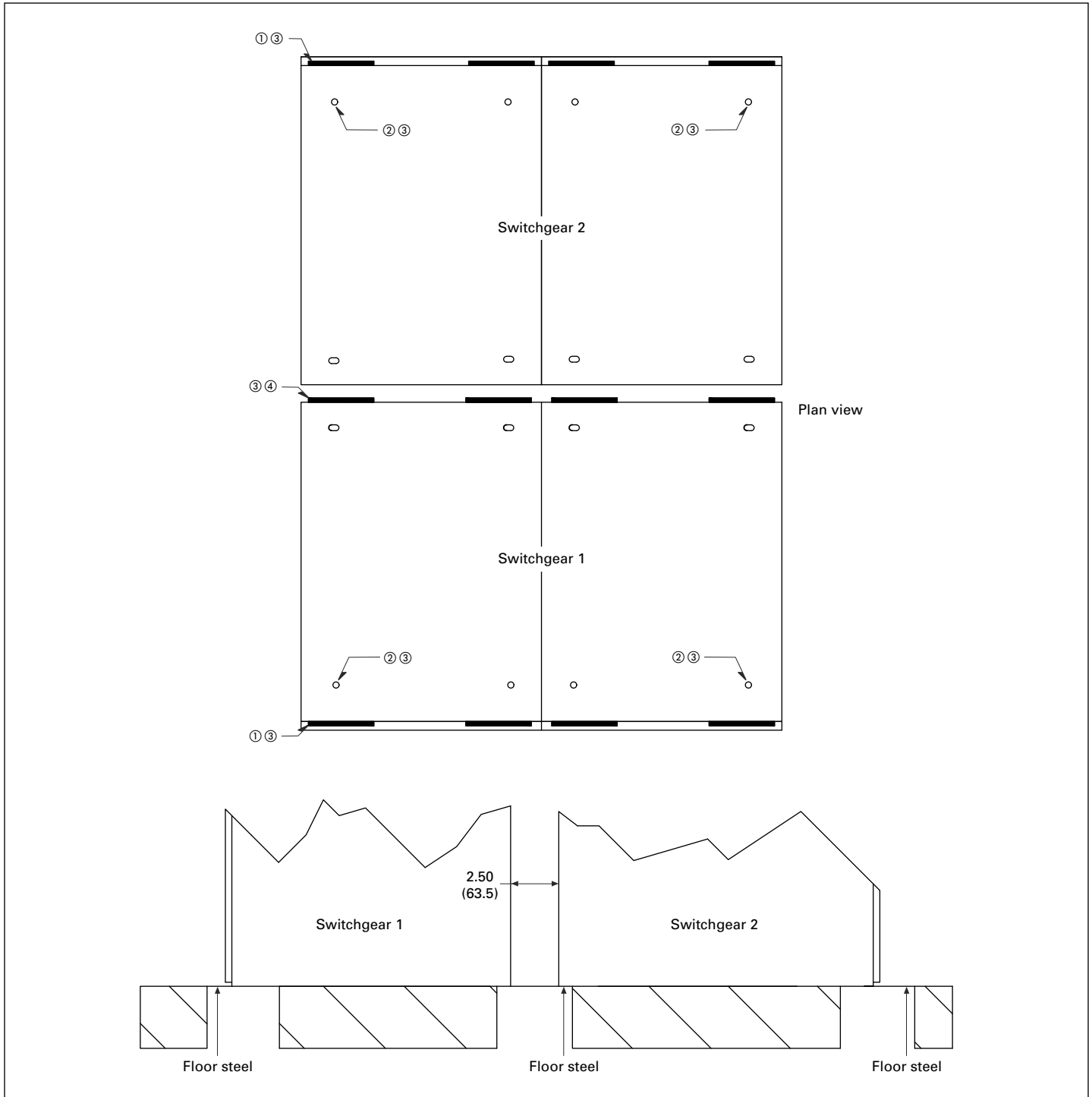

Figure 2. Welding of indoor structures to imbedded floor steel—front-access back-to-back Magnum switchgear

- ① 0.19 inches (4.8 mm) weld, 4.00 inches (101.6 mm) long at two places on front of each section starting 0.50 inches (12.7 mm) from each edge of structure.
- ② Internal bracket on each end of line-up to be plug welded to floor steel.
- ③ For nuclear installations, weld per AWS D1.1, alternatively, welding procedures and personnel qualifications may be performed IAW ASME BPVC Section IX and the inspections be performed IAW AWS D1.1, and/or D1.3, and/or D9.1.
- ④ 0.19 inches (4.8 mm) weld, 4.00 inches (101.6 mm) long at two places on rear of each section on Switchgear 1 only, starting 0.50 inches (12.7 mm) from each edge of structure where indicated.

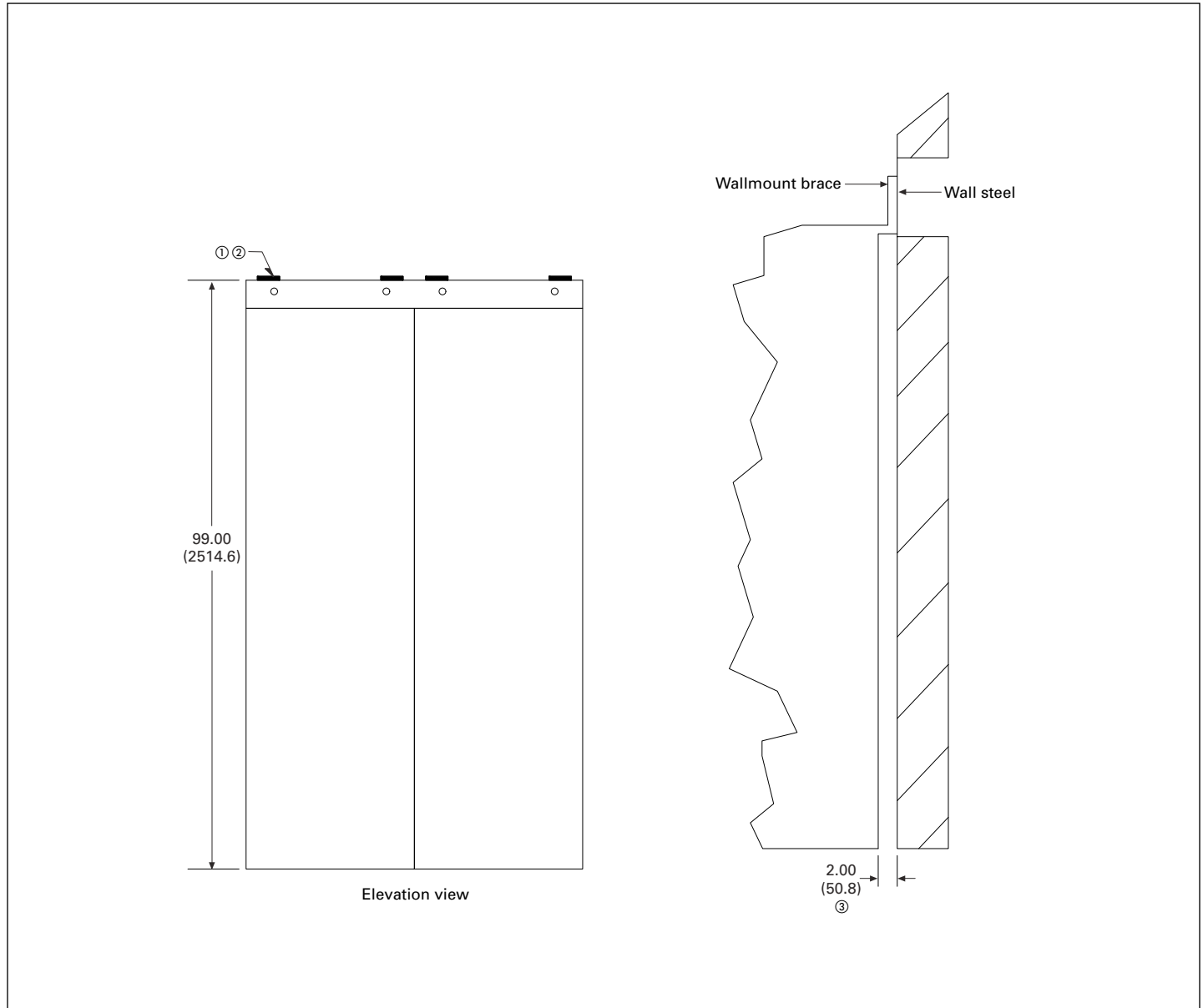

Figure 3. Welding of indoor structures to imbedded wall steel—front-access Magnum switchgear

- ① 0.19 inches (4.8 mm) weld, 4.00 inches (101.6 mm) long at two places on top of each section starting 0.50 inches (12.7 mm) from each edge of structure. See **Figure 1** for front-access front compartment bottom pan weld instructions.
- ② For nuclear installations, weld per AWS D1.1, alternatively, welding procedures and personnel qualifications may be performed IAW ASME BPVC Section IX and the inspections be performed IAW AWS D1.1, and/or D1.3 and/or D9.1.
- ③ A distance of 2.00 inches (50.8 mm), between the wall and the rear of the switchgear, is required to properly secure Front-Access Switchgear when using the rear wallmount brace.

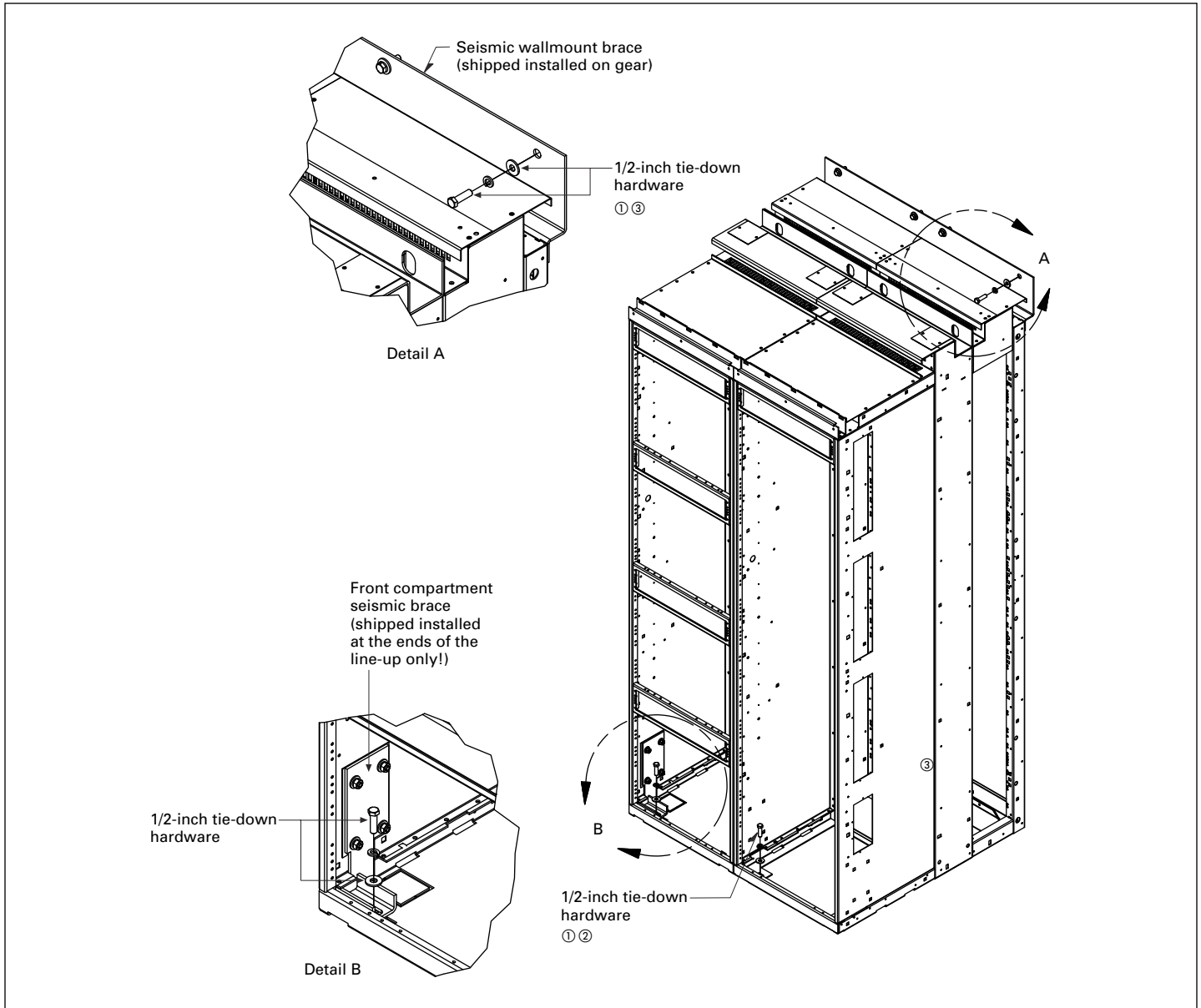

Figure 4. Magnum switchgear front-access rear frame seismic wall brace and front compartment seismic brace information

- ① Secure enclosure to pad and/or wall with Grade 5 hardware.
- ② Front compartment must be secured to pad for both rear frame wallmount and rear frame floormount applications.
- ③ A distance of 2.00 inches (50.8 mm), between the wall and the rear of the switchgear, is required to properly secure Front-Access Switchgear when using the rear wallmount brace.

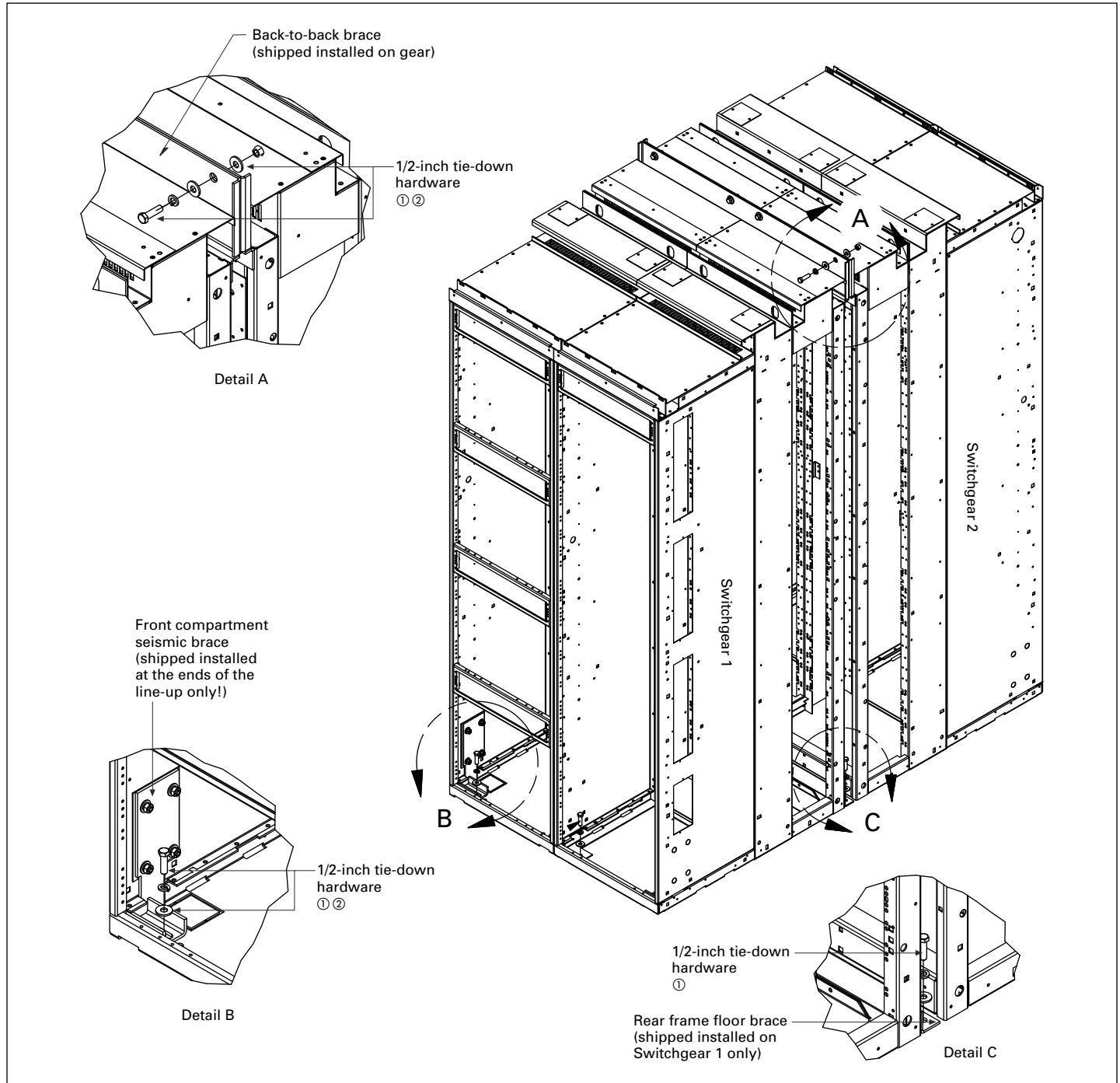

Figure 5. Magnum switchgear front-access back-to-back seismic brace information

- ① Secure each enclosure to pad and/or to adjacent back-to-back switchgear line-up with Grade 5 hardware.
- ② Front compartments of both switchgear line-ups must be secured to pad for back-to-back applications.

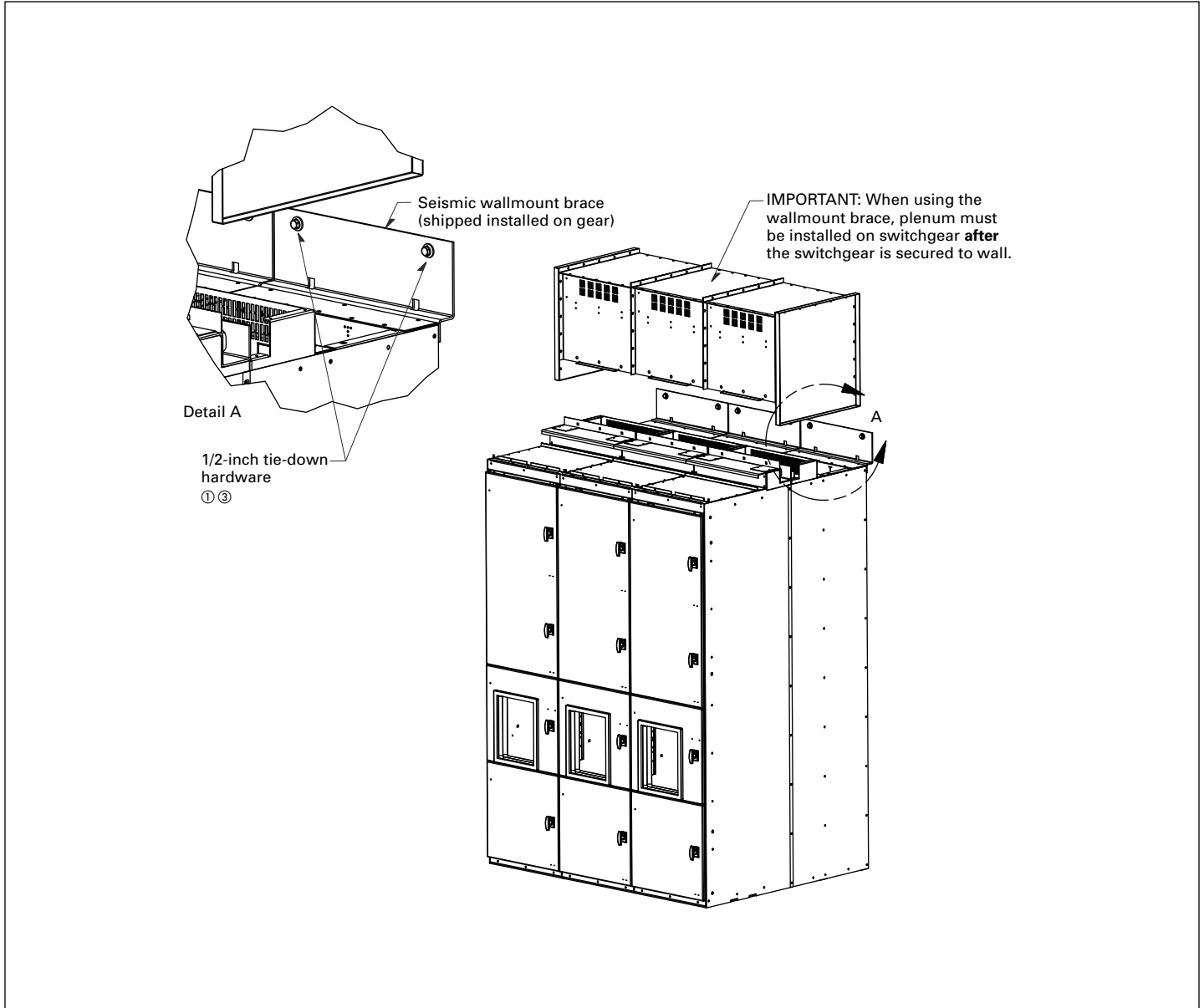

Figure 6. Magnum switchgear front-access rear frame seismic wall brace arc-resistant specific information

- ① Secure enclosure to pad and/or wall with Grade 5 hardware.
- ② Front compartment must be secured to pad for both rear frame wallmount and rear frame floormount applications (see Detail B on **Figure 4**).
- ③ A distance of 2.00 inches (50.8 mm), between the wall and the rear of the switchgear, is required to properly secure Front-Access Switchgear when using the rear wallmount brace.

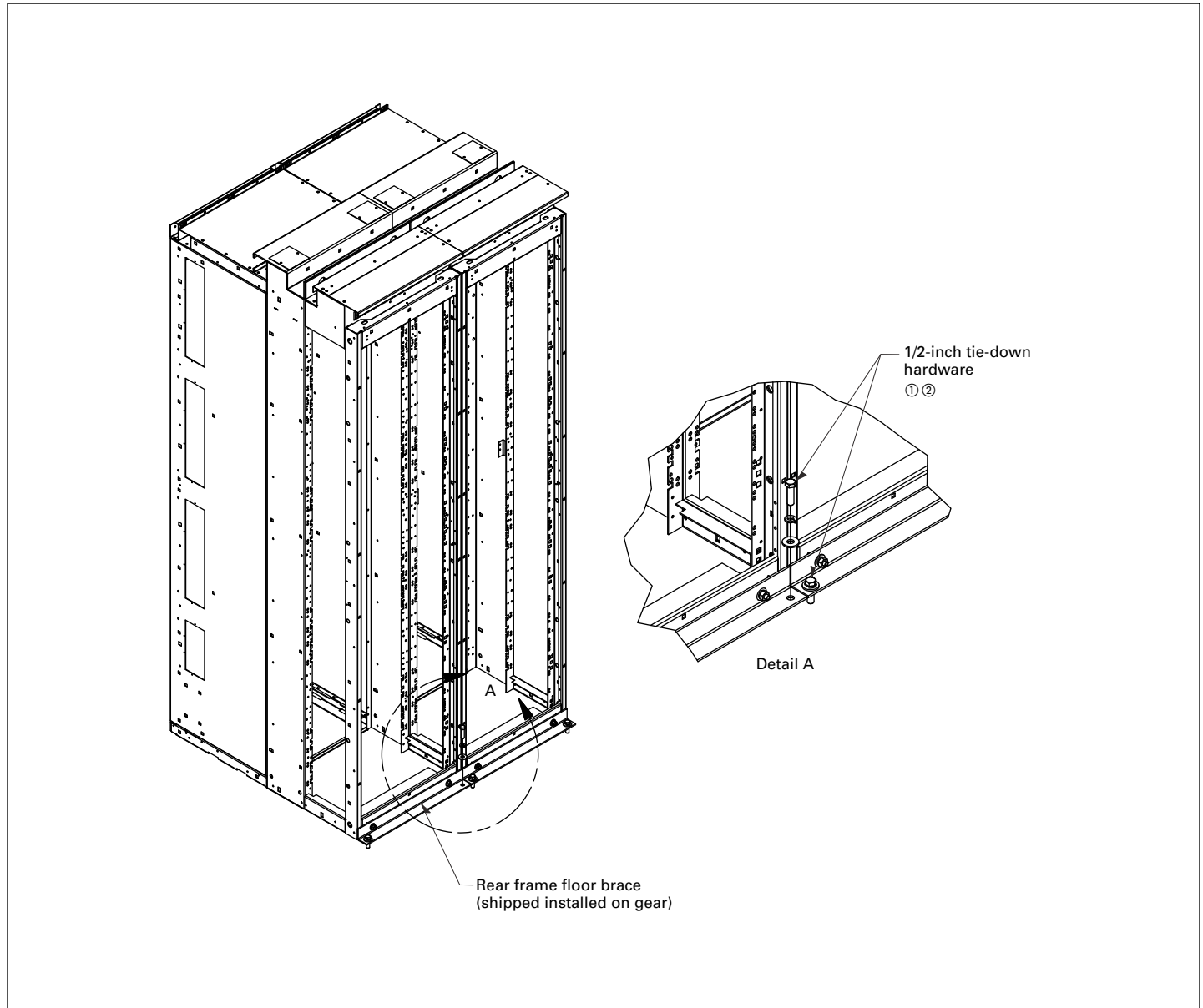

Figure 7. Magnum switchgear front-access rear frame seismic floor brace information

- ① Secure enclosure to pad with Grade 5 hardware.
- ② Sufficient clear space, between the wall and the rear of the switchgear, should be provided to allow for proper attachment of the switchgear to the pad.

Eaton
1000 Eaton Boulevard
Cleveland, OH 44122
United States
Eaton.com

© 2016 Eaton
All Rights Reserved
Printed in USA
Publication No. IL019116EN / Z18392
July 2016