

Pow-R-Line XD switchboards

Contents

Description	Page
Safety measures	2
Pre-installation: receiving, handling, and storage	3
Pre-installation preparation	5
Considerations for seismic qualified installations	6
Electrical connection of switchboard sections	8
Energizing switchboard	15
Maintenance	15
Appendices	19





Powering Business Worldwide

Safety measures

This publication contains instructions on the installation of Eaton brand Pow-R-Line XD™ low-voltage distribution switchboards. Any person or persons who designs, purchases, installs, operates, or maintains new systems using these products must understand the equipment, its markings, and its limitations.

Hazardous voltages in distribution switchboards and all other electrical equipment pose a potential hazard to life and property. Please follow instructions, labeling, and applicable codes and standards for installation, maintenance, and operation of this equipment and its components. Only "Qualified Persons" should install and/or service this equipment. NFPA® 70—National Electrical Code® defines a "Qualified Person" as "One who has skills and knowledge related to the construction and operation of electrical equipment and installations and has received safety training on the hazards involved."

Standard symbols have been established for recognition of potentially hazardous situations and conditions. Please review and understand the critical warning symbols shown below. These symbols will appear on safety labels affixed to the product. Installers should always read and understand these labels before working on equipment.

Symbol	Meaning
	The addition of either symbol to a "Danger" or "Warning" safety label indicates that an electrical hazard exists that will result in personal injury if the instructions are not followed.
	This is the safety alert symbol. It is used to alert you to potential personal hazards. Obey all safety messages that follow this symbol to avoid possible injury and death.

Eaton's liability for any errors or omissions in this document is limited to the documentary correction of errors. Eaton will not be responsible in any event for errors or omissions in this document or for any damages, incidental or consequential (including monetary losses), that might arise from the use of this document or the information contained in it. Information in this publication is not intended for use as a training manual for non-qualified personnel. The information or statements in this publication concerning the suitability, capacity, or performance of the switchboard(s) may not cover all configurations of this custom-built product. Eaton has made all reasonable efforts to ensure that the instructions in this document are adequate and free of material errors and omissions. Eaton will, if necessary, explain issues that may not be covered by the document. The information contained in the Instruction Leaflet is subject to change without notice.

Introduction

This instruction manual is designed to supplement other industry standards including all local, state, and federal codes and safety regulations, such as OSHA, NFPA 70 (National Electrical Code), NFPA 70E (Standard for Electrical Safety Requirements for Employee Workplaces), NEMA® PB2.1—General Instructions for Proper Handling, Installation, Operation and Maintenance of Deadfront Distribution Switchboards Rated 600 V and Less, other workplace electrical installation requirements, and all safety rules.

Safety

Due to the weight and size of switchboards and dangers from electrical hazards, every precaution should be taken to maintain safe working conditions when handling this equipment. Due to the custom nature of switchboards and the site variables, every potential situation cannot be anticipated. Safety must always be the overriding factor.

Always follow all instructions and all safety guidelines published by OSHA and other industry and local, state, and federal agencies.

 **DANGER**

"DANGER" INDICATES AN IMMINENTLY HAZARDOUS SITUATION THAT, IF NOT AVOIDED, WILL RESULT IN DEATH OR SERIOUS INJURY.

 **WARNING**

"WARNING" INDICATES A POTENTIALLY HAZARDOUS SITUATION THAT, IF NOT AVOIDED, CAN RESULT IN DEATH OR SERIOUS INJURY.

 **CAUTION**

"CAUTION" INDICATES A POTENTIALLY HAZARDOUS SITUATION THAT, IF NOT AVOIDED, CAN RESULT IN MINOR OR MODERATE INJURY.

CAUTION

"CAUTION" USED WITHOUT THE SAFETY ALERT SYMBOL INDICATES A POTENTIALLY HAZARDOUS SITUATION THAT, IF NOT AVOIDED, CAN RESULT IN PROPERTY DAMAGE.

Pre-installation: receiving, handling, and storage

Receiving

Upon delivery, use the packing list to confirm the number of items against what was received to ensure that the shipment is complete. Any discrepancies should be noted on the freight bill before signing. Report any shortages or damage to the freight carrier immediately.

Larger items, such as indoor traveling lifters, are shipped in separate cartons or boxes. Other loose and unmounted items may be packed in the same box as the lifter. These items, such as shipping split hardware, should be logged in and set aside in a safe location until the assembly has been set in its final position.

Immediately upon receipt of the switchboard, the plastic covering should be carefully removed and a thorough inspection of each section should be made to detect any damage incurred during shipment. Any damage should be noted on the bill of lading (freight bill) and the consignee receiving the equipment should notify the freight carrier. **FAILURE TO NOTIFY THE FREIGHT CARRIER OF DAMAGE IN A TIMELY MANNER MAY RESULT IN THE CONSIGNEE ASSUMING THE COSTS ASSOCIATED WITH REPAIR OR REPLACEMENT OF DAMAGED EQUIPMENT.**

After inspection, it is recommended that a plastic covering be used to protect the equipment from dust, dirt, moisture, and damage until ready for installation.

The switchboard should remain attached to its shipping skid until it has been moved into its final installation position.

Handling

⚠ WARNING

SWITCHBOARD IS TOP-HEAVY. USE CARE IN HANDLING.

Switchboards are top-heavy. Switchboard sections may weigh more than 2000 pounds. Before moving or lifting, verify that the equipment used to handle the switchboard is within safe limits of its lifting capacity.

Switchboard shipping lengths will vary. Each shipping section is bolted with lag bolts to heavy wooden skids that extend beyond all sides of the switchboard.

Use of lifting means

Lifting means are a part of each switchboard shipping length. Lifting a switchboard by crane is the recommended method for moving this equipment. At least four (4) lift points (two forward, two rearward) are to be utilized to lift PRLXD switchgear shipping sections. These lift points are identified with labels. See **Figure 1**.

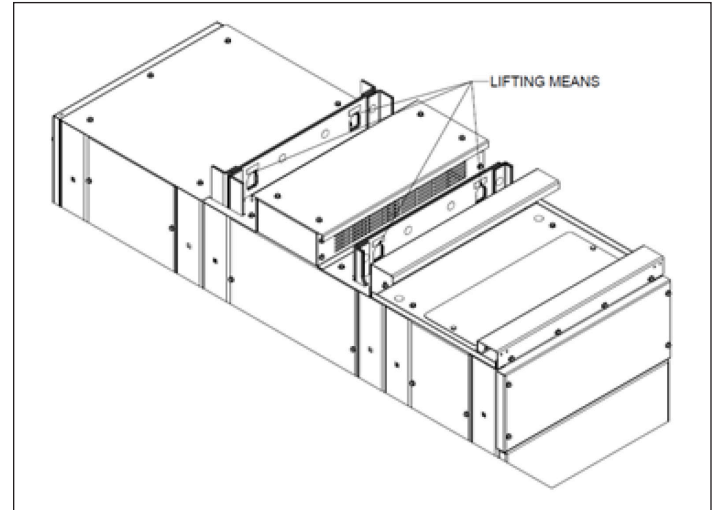

Figure 1. Typical indoor lifting means

DO NOT pass cables or chains through the holes in the lifting means. Use cables or chain with hooks or shackles rated for the load and weight of the switchboard shipping length to be lifted. The angle of the lifting cables or chains is not to be any less than 30 degrees from horizontal with 45 degrees or larger preferred.

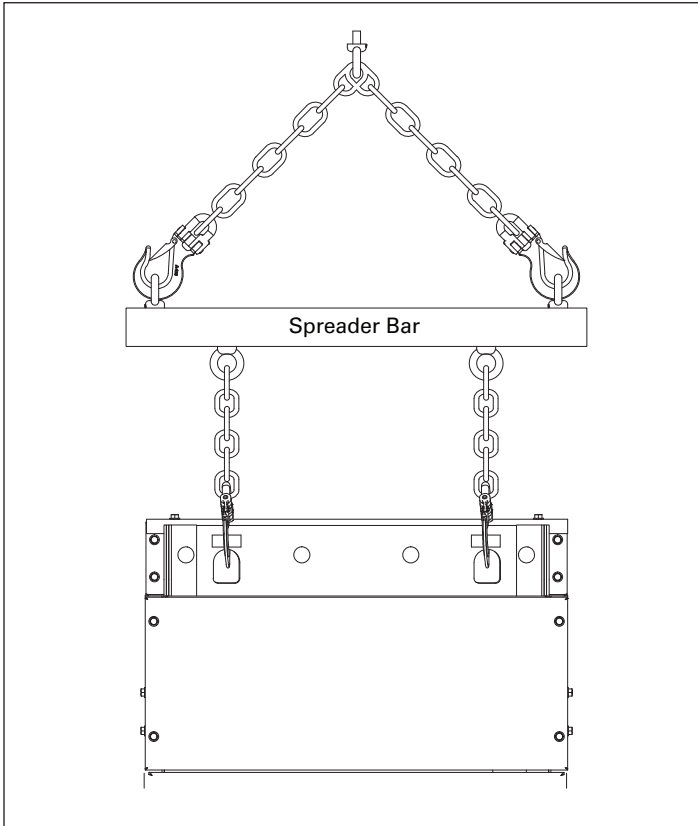

Figure 2. Front view

Prepare a sling and a spanner or spreader (see **Figure 2** and **Figure 3**). Eaton does not provide chain, cables, shackles, hooks, spanner, or spreader.

Chains/cables must be securely attached to hooks, eyes, and shackles, and the spanner/spreader. Prior to lifting, check the security of the rigging assembly. Use the crane to bring the assembly taut without raising the switchboard from the floor.

Check the security of the rigging again. Make any necessary adjustments before moving the equipment.

Slowly lift equipment to the minimum height from the floor required to safely relocate it. Move the equipment to approximately 2 inches above its resting place. Safely make a visual inspection of the rigging. If necessary, return the switchboard to its original resting place to make any modifications necessary to the rigging.

Forklifts

A forklift may be used for handling switchboards. Only personnel trained for that equipment should operate forklifts.

Be sure that the ground surface is solid, and follow all safety recommendations for operating the forklift. Be aware of wet or slick floors and surfaces, which can affect stopping and turning. Check labeling on the switchboard packaging material for additional information.

Verify that the forklift load and lifting ratings are within safe limits for the weight of the switchboard being lifted.

Do not lift switchboard from the front. Damage to components, such as breakers, fusible switches, and metering, can result.

⚠ CAUTION

SWITCHBOARD IS TOP-HEAVY. USE CARE IN HANDLING.

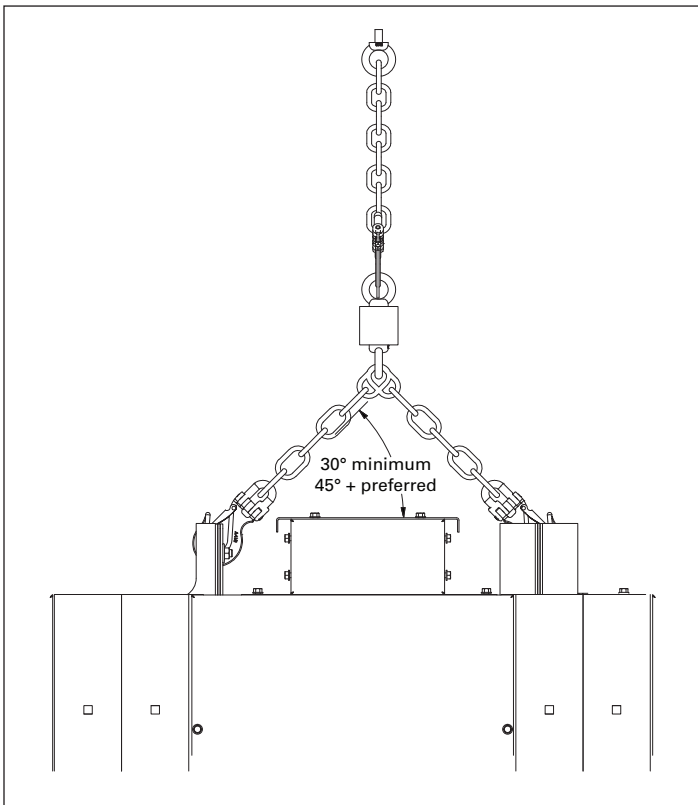

Figure 3. Side view

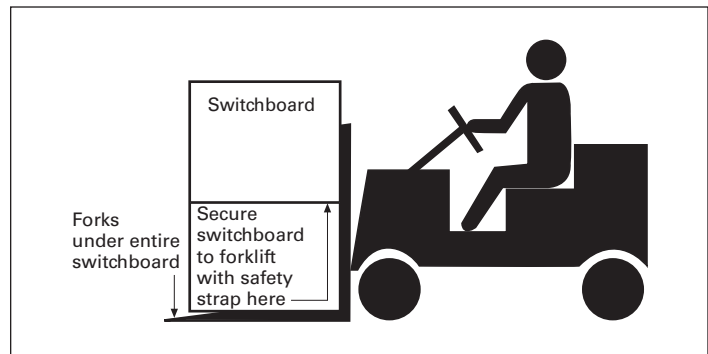

Figure 4. Forklift

Note: Always use caution when moving switchboards, which are top-heavy equipment.

The forks or blades of the forklift must run through the entire switchboard shipping length and be extended to the outermost sides of the wooden shipping skids (see **Figure 4**).

Secure the switchboard with a safety strap, belt, or leash approved for this purpose. Take care in positioning the strap to ensure stability of the equipment and confirm that it is not in an area that will damage components.

Slowly lift equipment to the minimum height from the floor required to safely relocate it.

Rollers

Rollers should only be used on solid and flat surfaces, such as a finished floor. Only use rollers that are suitable for this purpose.

Storage

Switchboards, which cannot be immediately installed and energized, should be stored in an indoor dry, clean, and heated environment.

Do not store in areas where conditions such as dampness, changes in temperature, cement dust, or a corrosive atmosphere are present.

Should the storage area be prone to moisture condensation, take precaution by making sure that the switchboard is covered, and install temporary heating equipment. Approximately 250 watts per vertical section are required for average conditions.

Switchboards should be placed on solid, level surfaces for storage. Switchboard sections must remain in an upright position at all times. Laying switchboard sections on their back or side can result in permanent damage to components and the switchboard structure.

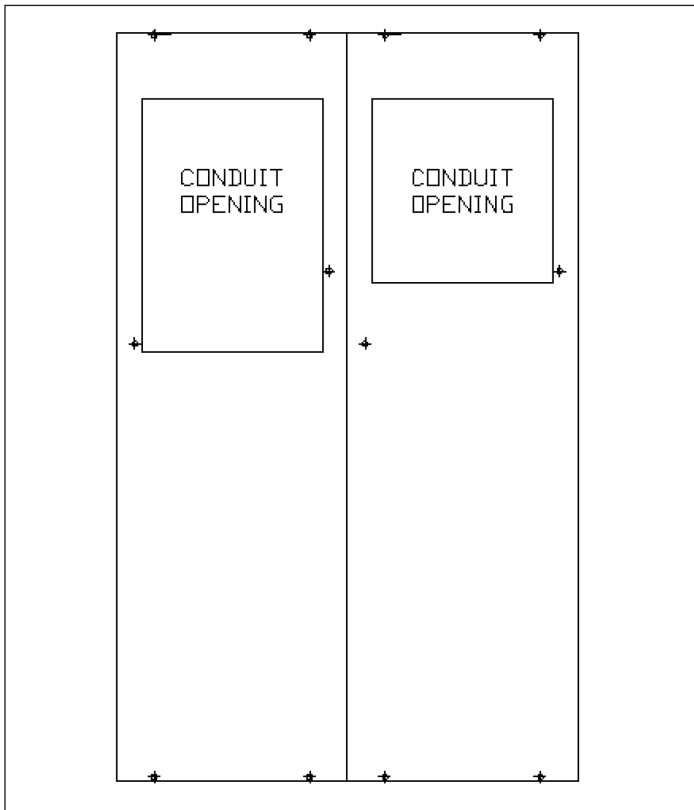

Figure 5. Conduit space drawing—floor plan

Note: Used for reference only. See manufacture's switchboard drawings for actual space.

Pre-installation preparation

The permanent location of switchboards must be on a smooth, solid, and level (no more than ± 0.125 inches per every 3 feet) foundation. Alignment is verified in the factory prior to shipment.

An uneven foundation can cause misalignment of sections, units, doors, and other parts.

If the gear is to be placed on a housekeeping pad that does not extend out front of the gear far enough for operators to stand on, you may violate height rules relative to the National Electrical Code (NEC®) and utility meter heights where applicable.

When embedded anchors or channel sills are used, materials and attachments must be adequate to support the structure(s). Switchboard sections must be aligned and level over the length of the installation.

From manufacturer's drawings, determine the layout of the electrical distribution equipment for each location. Verify and confirm that the available equipment space and equipment location(s) are in compliance with the minimum working space clearances per the NEC.

Refer to the manufacturer's switchboard drawings for available conduit area in each section before installing the finished grade flooring (see **Figure 5**). Conduits must be installed in conduit area shown to ensure compliance with NEC wire bending space requirements.

Note: Conduit areas may vary in each section of a multi-section switchboard lineup.

The preferred method of anchoring the switchboard is by fastening the switchboard to steel channels that are properly and permanently embedded in a concrete floor or by using anchors designed for this purpose.

Conduits, floor, and/or wall openings, such as busway or other penetrations, should be located relative to the space shown on the manufacturer's drawings.

Refer to the National Electrical Code for installations in damp locations for additional requirements.

The entire area around the switchboard should be thoroughly cleaned of all debris.

Considerations for seismic qualified installations

Switchboards that are “seismic qualified” require additional considerations. Because electrical equipment is installed as part of a system, pre-engineering layouts are critical in seismic applications.

When Eaton switchboards are marked as “seismic qualified,” anchoring the switchboard is critical. Experienced engineers in seismic requirements should select methods and techniques of attachment and tested anchoring systems. Embedded concrete anchors or steel attachments must be adequate to resist the forces established by the local building code. Bolts of the proper grade of steel must be correctly sized and torqued. The embedded anchors must be correctly installed in accordance with the method specified by the anchor manufacturer. Refer to *seismic instructions* in TD01508002E provided by Eaton for more information.

Conduit layout in concrete for cables entering and/or exiting the bottom must be designed and installed to prevent damage from an earthquake. If top entry is necessary, seismic fittings or flexible conduit is needed.

Consult applicable local building codes and regulatory agencies for other specific requirements for seismic installations. Contact Eaton for additional information.

Installation

Use caution and appropriate equipment and practices when moving switchboard into its final position.

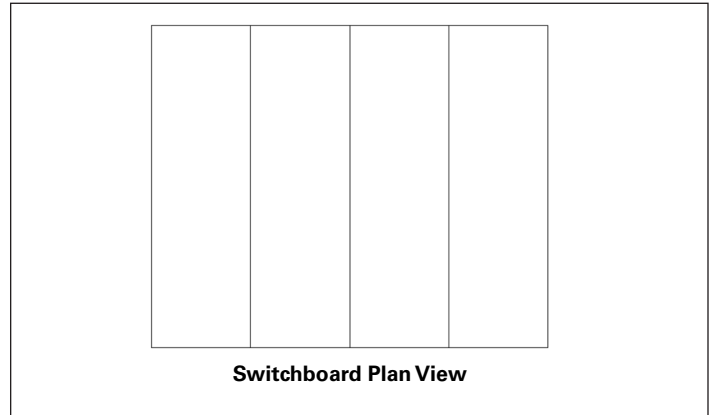

Figure 7. Example of front- and rear-aligned switchboard

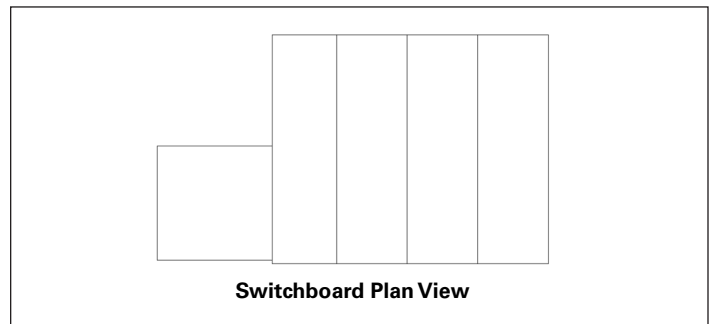

Figure 8. Example of front (only) aligned switchboard

Sections may contain factory cross bus and/or cable to connect power between switchboard structures and other components. Installers should note the location and orientation of all splice plates and/or cables as reference for installation once sections are joined.

If supplied, remove splice plates and associated hardware, again noting the orientation for reinstallation once switchboard is in place. If additional hardware is needed to complete these connections, extra hardware will be provided. For shipping purposes, it will typically be secured inside one of the structures. Keep bus and hardware in a clean and protected environment to guard against damage until reinstallation. Protect any factory-installed cables (wire) used to connect components between sections from damage when moving switchboard sections into place.

Use caution and appropriate equipment and practices when moving switchboard into its final position.

WARNING
SWITCHBOARD IS TOP-HEAVY. USE CARE IN HANDLING.

Exercise caution while maneuvering top-heavy switchboard sections into place. Switchboard sections must always remain in the upright position during installation. Use care when moving the switchboard so as not to damage the section, including the structural base and frame. Some switchboards house sensitive components, which can be damaged by rough handling.

CAUTION
SWITCHBOARD IS TOP-HEAVY. USE CARE IN HANDLING.

Determine the switchboard orientation with the use of manufacturer’s drawings and markings on the switchboard sections.

Switchboards may be shipped in one or more sections joined by the manufacturer.

The drawing supplied with the switchboard will indicate the correct orientation of sections by section number. Each section will have a label with the UL listing mark designating “Deadfront Distribution Switchboard Section ___ of ___.” The manufacturer will fill in the blanks prior to shipment. An example: The first section of a three-section switchboard will read “Section 1 of 3.” Section 2 of 3 would be mounted adjacent per the manufacturer’s drawings (see **Figure 6**).

	Deadfront switchboard section ____ of ____
--	---

Figure 6. Label illustration

Multi-section switchboards are designed to be front- and rear-aligned or front (only) aligned. Drawings provided by the manufacturer and located in the switchboard will show footprint details. Orientation, as shown on the drawings, must be maintained (see **Figure 7** and **Figure 8**).

Prior to moving the switchboard sections into their permanent position, make note of all obstacles including conduit stubs. Implement a plan for safe transition and appropriate means to accommodate these obstructions. Take note of conduits entering through the bottom and at the top of the switchboard, to ensure appropriate clearances from structure, cross bus, ground, and components.

Refer to the National Electrical Code (NEC) for required switchboard clearances.

When unpacking the switchboard, exercise care not to scratch or mar the finish. Repair all scratches with touch-up paint, which is available from Eaton. Remove shipping skids and all packaging material. Remove any temporary shipping braces or spacers.

Where two or more switchboard sections are to be joined together, they should first be aligned and all sections leveled.

Once aligned and leveled, attach switchboard sections together.

Attaching switchboard sections

The manufacturer has provided hardware with the equipment to join switchboard sections. The hardware includes 3/8 x 1 inch hex bolts, washer, and preinstalled nut plates (see **Figure 9**), in the front and cage nuts in the rear.

Holes are provided on the side of each switchboard section for this purpose. For non-Seismic applications, three holes are located on the side of each section toward the front and back (see **Figure 10**). For Seismic applications, an additional three holes and hardware are provided in the front of the cable compartment for additional security (for a total of nine bolts on each side).

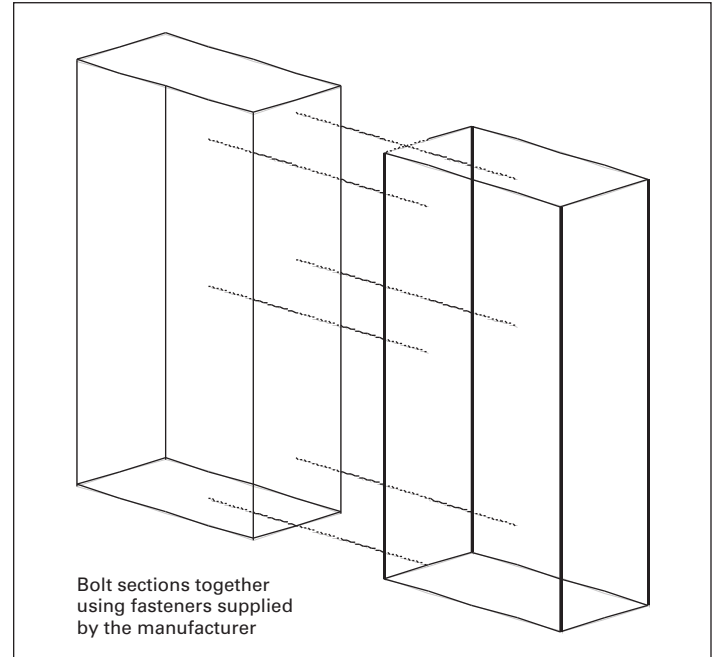

Figure 11. Joining switchboard sections

Join sections by using the hex bolts and nut plates through the holes provided (see **Figure 11**). While maintaining the level and alignment of the structures, torque each connection to the values shown in **Appendix A, Table 1**.

Once the switchboard structures are attached, visually inspect the board for foreign objects and visually inspect the structure for proper clearances of live parts.

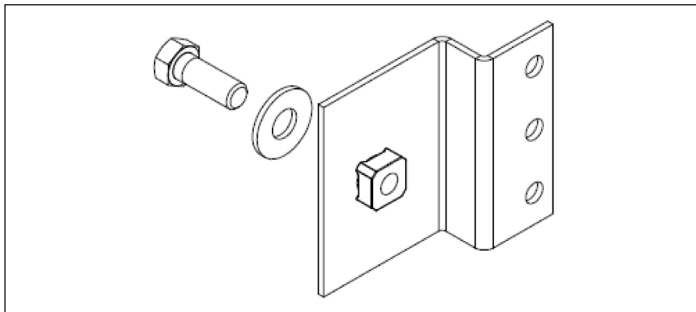

Figure 9. Hardware

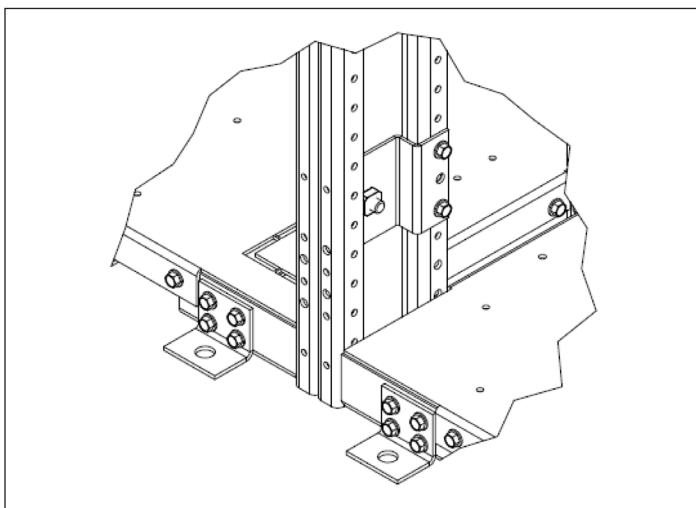

Figure 10. Switchboard section connection

Electrical connection of switchboard sections

Several methods may be used to make electrical connections within switchboards. More than one of these methods may be used in a section and/or switchboard lineup. These include bus splice plates and busway connections. Consult the manufacturer's drawings for details for each switchboard section.

Remove structure covers as needed to access switchboard. Retain all cover mounting hardware and covers for reassembly. Protect hardware and parts from moisture, debris, and damage.

Splice plates

Splice plates are short pieces of bus bar that join the main bus running horizontally through multiple section switchboards. See **Figure 12**.

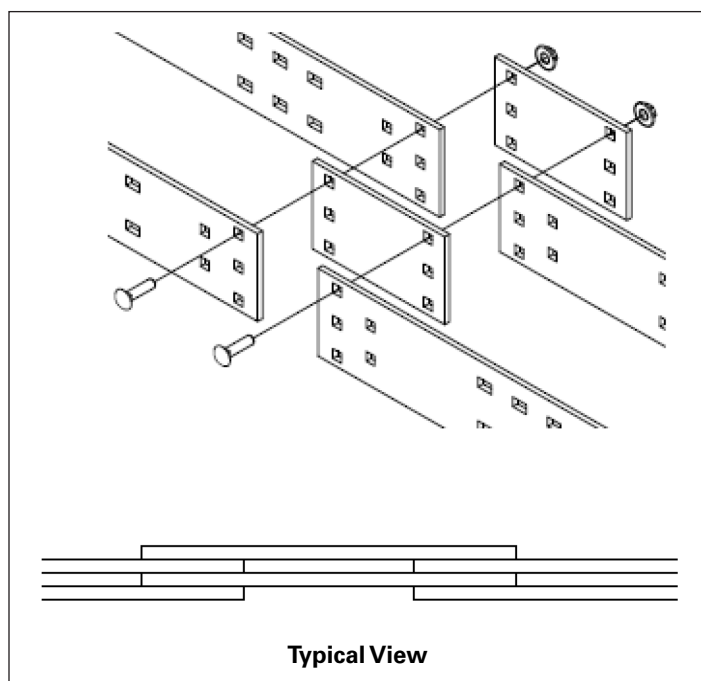

Figure 12. Splice plates

For larger amperage switchboards, multiple splice plates are to be used on the same phase. Clearances must be maintained. If you are unsure about the correct installation, contact Eaton before installing the splice plates.

Splice plates are used to attach the main horizontal bus between switchboard sections or shipping splits. While maintaining the correct phase orientation and sequence, install splice plates with the carriage bolts and hex nuts with captive Belleville washers supplied by the manufacturer. Refer to Appendix A, **Table 1** for torque values.

Carriage bolts must align with the corresponding square holes in the special washer provided. If multiple splice plates are used, install in the same sequence as shipped from the manufacturer. The neutral (when furnished) and ground bus should be connected in the same manner.

Inspect splice plates and main fixed horizontal bus prior to installation. If there is any suspected damage, contact the manufacturer immediately for replacements. **NEVER ENERGIZE ANY SWITCHBOARD WITH DAMAGED BUS OR COMPONENTS.**

It is recommended that the head of the carriage bolt be mounted from the front of the switchboard with the hex nut with Belleville washer positioned to the rear.

Repeat the process until all holes in the horizontal bus are connected with bolts and nuts for each shipping split. Inspect connections to ensure that there is no foreign material at the connection point and that all connections are properly aligned and bolts are seated.

Torque all connections to torque requirements on labels affixed to each switchboard and as shown in **Appendix A, Table 1**.

Installation of incoming switchboard connections

⚠ DANGER

DE-ENERGIZE SWITCHBOARD—HAZARDOUS VOLTAGE. WILL CAUSE SEVERE INJURY OR DEATH.

DO NOT work on electrical equipment while it is energized. Verify that power entering the equipment is de-energized at the source.

Power is normally brought into a switchboard either by cable or by busway (bus duct).

Remove structure covers as needed to access switchboard. Retain all cover mounting hardware and covers for reassembly. Protect hardware and parts from moisture, debris, and damage.

Note: As a minimum, all switchboard connections are rated for use with 75 °C or higher rated conductors. When wire is used with temperature ratings above 75 °C, it shall be sized based on the ampacity of wire rated 75 °C.

Wire/cabling

When cable connections are used, either lug provisions, mechanical set screw lugs, or compression lugs are typically supplied (see **Figure 13**). See factory drawing for specific lug terminations and wire ranges. Some utilities make their own service entrance connections. In these cases, a lug landing pad is typically supplied in lieu of lugs. These are designed to the specific utility's requirements. Refer to the manufacturer's drawings for specifics covering this connection.

Once the conductors are pulled, the cables should be formed in the space provided. Clearly identify and segregate conductors by phase and neutral. Care should be taken in forming insulated cables to ensure that no insulation is forced permanently against the edges of any metal parts.

Using appropriate tools, the installer must strip the conductor insulation sufficiently to fill the entire barrel of the connector with bare, uninsulated conductor. Conductor must be stripped without damage to the conductor strands. Bare strands should be of equal length (flush) on the end cut.

Do not strip off more insulation than needed. Exposure of bare conductor outside lug can compromise clearances.

The connector and conductor should be free of all foreign debris.

Never clip cable/wire strands in order to fit within connectors. If cable/wire does not match the rating of the connector, contact the manufacturer.

Use an antioxidant compound, if required. Insert bare conductor into lug so the bare conductor fills the full length of the lug body. Tighten lug, and then torque to levels indicated on the switchboard label.

If compression lugs are used, use a crimping tool approved for that specific lug manufacturer and lug size. Follow instructions provided by the manufacturer of the crimp tool.

Install the lug on the lug pad using the existing hardware. Torque hardware using information provided on switchboard labeling. Refer to **Appendix A, Table 1** for torque values.

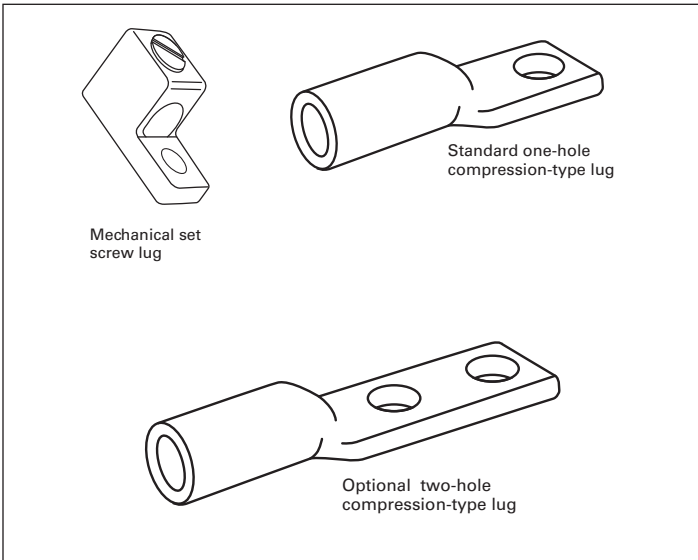

Figure 13. Screw and compression lugs

Effective July 2019

Power cable lashing

Where power cables will be connected, each switchboard assembly is provided with either crimp or mechanical lug landings arranged so that the lugs are pointed up or down at a 45 degree angle to reduce the cable bending required for installation.

The lashing of cables are required for all of the following conditions:

1. All 800 ampere frame breakers.
2. All breaker frames with short circuit ratings above 65 kA.

If cable lashing is required, follow the methods given in **Figure 14**.

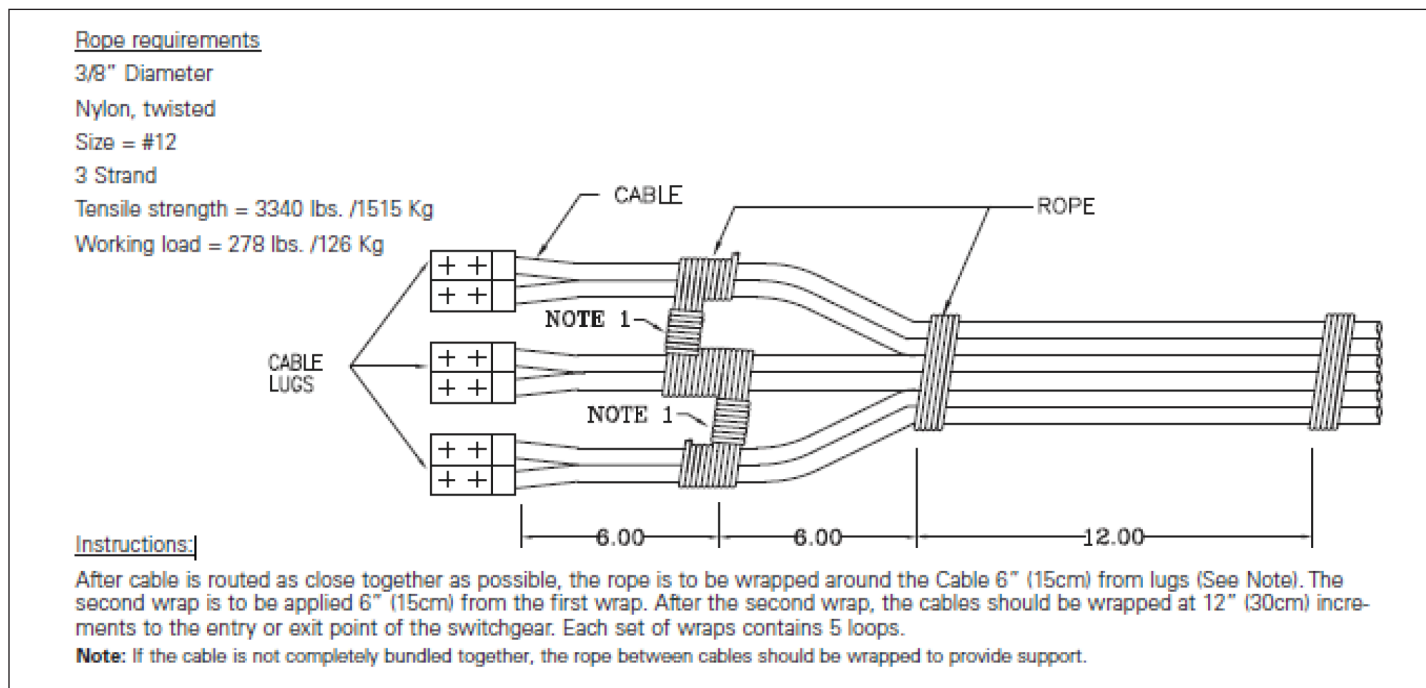

Figure 14. Cable lashing instructions

Busway

A switchboard may include one or more provisions for connection to busway. Busway can feed the switchboard, be fed from the load side of an overcurrent device within the switchboard, or both.

Switchboards with busway connection(s) contain flange connection "tie-bar(s)" assembled in the appropriate section. The tie-bars will accept the corresponding busway flange extension. Consult switchboard and busway drawings for specifics. The tie-bars are a transition between the switchboard conductors and the busway flange extension, and are assembled as part of the switchboard section.

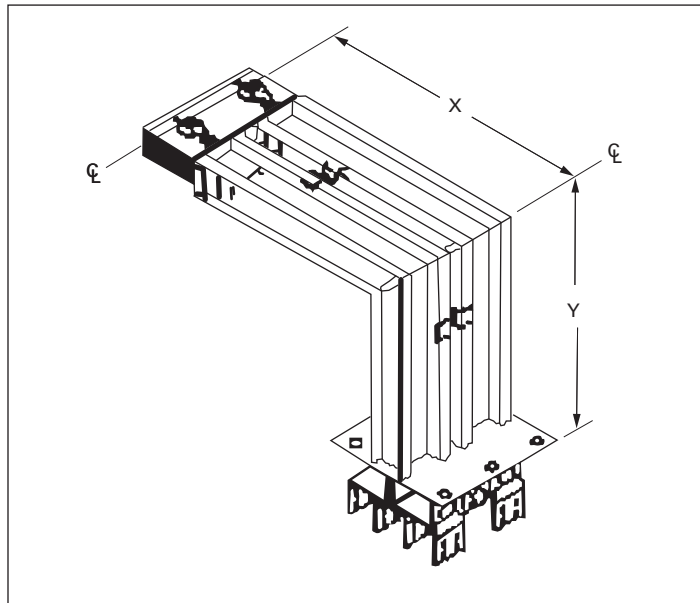

Figure 15. Downward elbow right flange

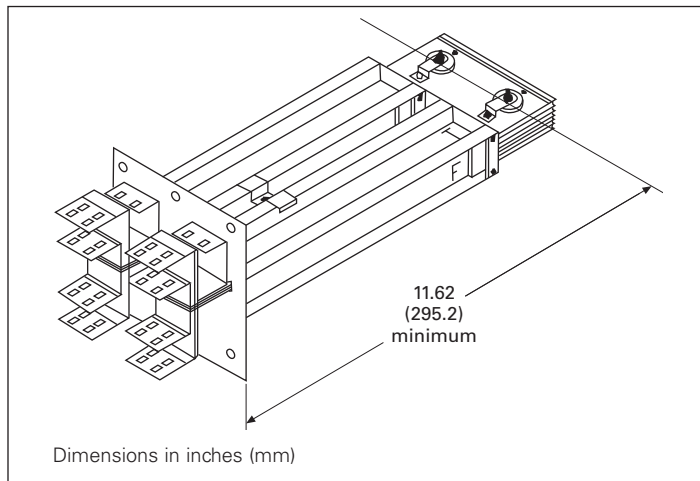

Figure 16. Standard flange

The switchboard flange has a corresponding piece shipped with the busway run. The busway installer attaches the two flange pieces together prior to energization (see **Figure 15** and **Figure 16**).

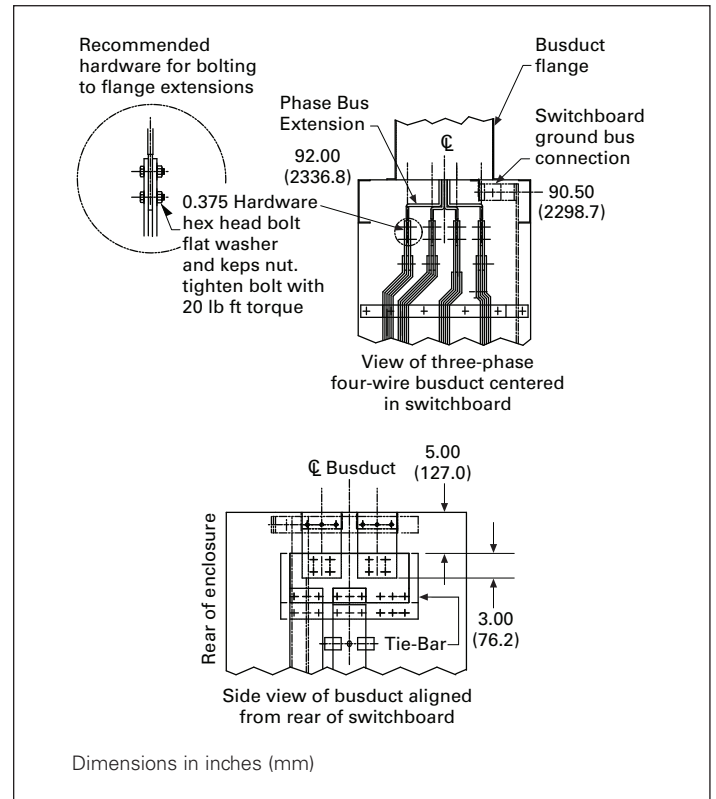

Figure 17. Busway/busduct

The bus assembly is completely formed and drilled for connections, including phase bussing and neutral, if needed. Additionally, grounding connections are supplied.

Busway typically enters a switchboard section through the top. However, busway may attach from the bottom, back, or side of the switchboard in special configurations (see **Figure 17**).

Temporary bracing may be provided to support the busway assembly in the switchboard during shipment. All temporary bracing must be removed after connections are completed.

The switchboard structure should NOT be used to support any busway run or flange and extension.

Bolts and hex nuts with captive Belleville washers are supplied by the manufacturer with the switchboard to connect the switchboard installed flange and the busway flange. Follow instructions shipped with the switchboard and with busway flange.

When a busway connection is supplied on an outdoor switchboard, sealing the busway connection is critical. Upon completing the necessary bus connection, the installer is responsible for sealing the connection point where the busway flange connects to the chimney top cover or side/rear cover. A tube of RTV 732 silicone sealant and a roll of gasketing material are provided with the switchboard for this purpose.

For installation instructions on busway runs, please refer to NEMA publication BU 1.1-2000, *General Instructions for Handling, Installation, Operation and Maintenance of Busway Rated 600 V or Less*.

Pre-energizing procedures and inspection

Before energizing any switchboard, perform a comprehensive inspection to make certain that the switchboard is ready to be energized. This includes the following steps:

1. Verify that the switchboard is not energized.
2. Visually inspect the switchboard and remove all foreign materials, such as tools, scraps of wire, and other debris from all switchboard sections.
3. Remove and discard all packing materials and temporary shipping braces from the switchboard.
4. Any accumulation of dust and dirt should be removed with a vacuum cleaner. Use a lint-free cloth to remove dust and dirt on other surfaces. Never use compressed air as this may blow contaminants into electrical and/or electronic components. Never use solvents or other chemicals to clean surfaces or components.
5. Visually inspect all ventilation points to ensure that there is no blockage or debris. Remove any debris that is present.
6. Verify that all field bus and wire connections have the proper torque per instructions on the switchboard and on components.
7. All factory connections are made using calibrated power tools. However, vibrations do occur in transit and handling. Verify factory connections by checking at least 10% of the total factory connections for tightness. If this spot check reveals loose connections, proceed to check all factory connections. These connections include bus hardware connections, circuit breaker and switch terminals, contactors, metering, and other connections, including the incoming terminals.
8. Visually inspect switchboard insulators, bus bar, and conductors for damage. **DO NOT ENERGIZE IF DAMAGE FOUND.** Contact Eaton.
9. If fusible switch type overcurrent devices are used, verify that proper fusing has been selected and installed. Eaton does not typically supply switchboards with these fuses.

Overcurrent devices

Overcurrent devices are typically shipped in either the open (OFF) or “tripped” position. Manually close, and then open these devices to ensure that they are functioning properly. At the completion of this process, be sure that the overcurrent device is in the OFF or “tripped” position.

Inspect overcurrent devices for any visible damage. If damage is found, **DO NOT ENERGIZE** the switchboard. Contact Eaton.

Circuit breakers

Some circuit breaker types provide the ability to adjust trip settings. When shipped, settings are typically at the minimum rating. There are two types of trip units included in this group: adjustable thermal-magnetic and electronic trip units.

Thermal-magnetic trip units may have an adjustable magnetic setting. Use the engineering study recommendations, if available, to adjust to the proper setting. Low magnetic settings feeding high inrush loads, such as motors, could nuisance trip on startup. For specifics on breaker types, consult the circuit breaker instruction leaflets shipped with the switchboard.

Electronic trip units have several settings depending on the breaker ordered. Electronic trip units may include long-time (L), short-time (S), instantaneous (I), and ground fault (G) settings. These trip units are available in combinations LS, LSI, LSG, and LSIG. Check the electrical drawings, engineering study, or the engineer’s recommendations for these trip unit settings. For details on each type, refer to the Eaton circuit breaker and electronic trip unit instruction leaflets shipped with the switchboard.

For certain breakers with electronic trip units, a portable test kit is available from Eaton. An auxiliary power module is included in the test kit. This auxiliary power module powers the electronic trip unit when the board is de-energized and allows testing. The kit includes complete instructions and test times for testing long-time, short-time/instantaneous operations, and optional ground fault operation of the circuit breakers.

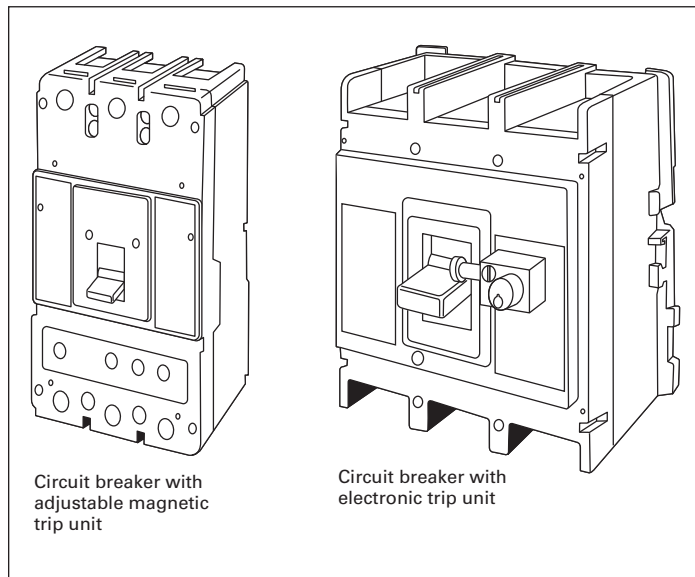

Figure 18. Circuit breakers

Overcurrent devices with ground fault protection

This switchboard may contain overcurrent devices with ground fault protection (GFP). The National Electrical Code may require ground fault protection for this installation. Other GFP applications may be used, including multi-level ground fault protection. Refer to the switchboard drawings and electrical construction drawings for usage and placement within the switchboard.

Ground fault protection may be installed integral to overcurrent device(s) or as a separate system. Separate systems typically are connected to a shunt tripping mechanism on an overcurrent device.

Visibly inspect connections on GFP systems, neutral sensors, and ground connections. Refer to manufacturer’s instructions for details.

Prior to shipment, the manufacturer has preset the ground fault protection at minimum set points. Adjust settings per engineered electrical plan drawings. If this information is not readily available, contact the design engineer or other qualified persons responsible for the specifics of the installation and system design.

When testing PRLXD switchgear with integral ground fault systems, please refer to *System ground fault Instruction Leaflet IB015002EN*. Prior to testing the GFP system, remove the neutral disconnect link(s) on the switchboard to isolate the neutral of the system from the supply and ground.

Confirm that the neutral connection has been run from the supply to the service equipment per the National Electrical Code.

All ground fault protection systems shall be performance tested when first installed on site. The test shall be conducted in accordance with instructions outlined in Article 230.95 of the National Electrical Code. This testing shall be conducted by a qualified person(s). A written record of this testing shall be made and shall be available for the Authority Having Jurisdiction (AHJ).

The interconnected system shall be investigated in accordance with the following instructions. Determine the location of the sensors around the bus of the circuit protected by the ground fault system. This can be accomplished visually with knowledge of which bus is involved. Identify all grounding points of the system to verify that ground paths do not exist that would bypass the ground fault sensors. The installed system is to be tested for correct response by application of full scale current into the equipment to duplicate a ground fault condition, or by equivalent means. It is recommended that this be performed by a qualified testing organization. Record the test date and results on the form provided in Appendix C of this Instruction Manual. Those in charge of the site’s electrical installation should retain the completed form and make it available to the AHJ.

Due to the varied types of devices and ground fault protection systems available, detailed testing instructions can vary. For detailed instructions, identify the specific type of device and ground fault protection system provided. Then refer to the separate instructions for that specific type of device.

Current transformers

Switchboards containing metering and monitoring equipment may contain current transformers (CTs) integral to the switchboard. Ensure that the load side of the CTs are connected or are shorted together with terminal block shorting means. Remove shorting means for normal CT operation with metering equipment. For additional information and instructions, refer to instruction leaflet shipped with the switchboard.

Preparing switchboard for insulation/megger testing

⚠ CAUTION
FAILURE TO SHORT OR DISCONNECT DURING SWITCHBOARD TESTING WILL RESULT IN FAILURE OF ELECTRONIC COMPONENTS.

Devices installed with control power fusing

Devices that require control power fusing can be easily damaged beyond repair if not disconnected during the testing phase. These devices include, but are not limited to, customer metering equipment, electronic breaker trip units, motor operators, and communication equipment.

⚠ WARNING
DISCONNECT POWER AT SOURCE BEFORE REMOVING OR INSTALLING FUSES. HAZARDOUS VOLTAGE WILL CAUSE SEVERE INJURY OR DEATH.

Prior to testing the switchboard, turn off all control power devices in the switchboard to prevent damage to components. The control power may be turned off by using the control power switch or by removing the fuses. Components that use power supplies include customer metering and certain breaker accessories, and these must be isolated before testing.

The following label will appear on the equipment:

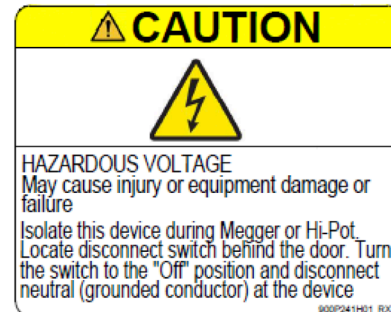

⚠ CAUTION
DO NOT TEST A CIRCUIT BREAKER WHILE IT'S IN SERVICE AND ENERGIZED.

⚠ CAUTION
TESTING OF A CIRCUIT BREAKER THAT RESULTS IN THE TRIPPING OF THE CIRCUIT BREAKER SHOULD BE DONE ONLY WHEN THE SWITCHBOARD IS DE-ENERGIZED.

⚠ CAUTION
FAILURE TO DISCONNECT CONTROL POWER DURING SWITCHBOARD TESTING WILL RESULT IN FAILURE OF ELECTRONIC COMPONENTS.

Failure to disconnect control power during switchboard testing will result in failure of electronic components and void manufacturer's warranty.

Surge protective devices (SPDs)

Prior to testing the switchboard, disconnect line and neutral connections to all SPD units in the switchboard. Keep hardware in a clean and protected environment to guard against damage until reinstallation.

⚠ CAUTION
FAILURE TO DISCONNECT LINE AND NEUTRAL DURING TESTING WILL CAUSE THE SPD SURGE PROTECTION SYSTEM TO FAIL AND WILL VOID THE WARRANTY ON THE DEVICE.

Failure to disconnect line and neutral during testing will cause the SPD surge protection system to fail and will void the warranty on the device. After testing, reinstall all connections.

The following label will appear on the equipment:

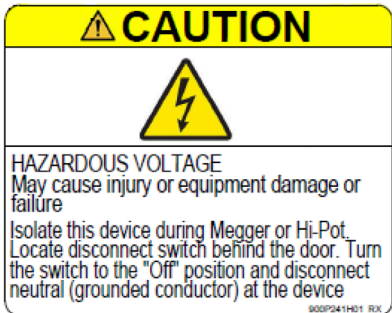

Pre-energizing switchboard insulation testing

Exercise extreme care to prevent the equipment from being connected to the power source while tests are being conducted.

Prior to energizing the switchboard, perform a Megger or DC test of the switchboard's insulation. With the neutral isolated from the ground and the switches and/or circuit breakers open, conduct electrical insulation resistance tests from phase to phase, phase to ground, phase to neutral, and neutral to ground. Retain results for use to compare to results produced in the future. A form for recording test results is provided in the appendix of this document. Prior to testing, remove all control power fusing and connections to products, which will be damaged in this test. See above.

⚠ WARNING
TO PREVENT DAMAGE TO GROUND FAULT CONTROL CIRCUITS, METERING CIRCUITS, OR OTHER CONTROL CIRCUITS WHEN MEGGERING SWITCHBOARD, ISOLATE CIRCUITS FROM SWITCHBOARD SYSTEM BEFORE BEGINNING THE MEGGER OPERATION. BE SURE TO RECONNECT THOSE CIRCUITS AFTER MEGGER TESTS ARE COMPLETED.
NOTE: SOME GROUND FAULT CIRCUITS MAY NOT BE FUSED; THEREFORE, ISOLATION OF THOSE CIRCUITS REQUIRES DISCONNECTING WIRING FROM BUS BARS.

DO NOT USE AC dielectric testing.

⚠ WARNING
DO NOT USE AC DIELECTRIC/MEGGER TESTING.

A test resulting in readings at or above 1 megaohm is satisfactory.

Post-testing

After testing, and with the switchboard de-energized, reconnect all devices, control fusing, and disconnects removed prior to testing. Reattach surge protective devices (SPDs).

Securing the switchboard

Reinstall all side covers, deadfront plates, doors, and trim parts on the switchboard using hardware supplied by the manufacturer. Take caution that conductors are not pinched between parts when installing the deadfront, cover plates, side sheets, and filler plates. All parts should be aligned and secured when installed. Do not leave holes or gaps in the deadfront construction. Clean up any debris in and around the switchboard.

Energizing switchboard

WARNING

HAZARDOUS VOLTAGE WILL CAUSE SEVERE INJURY OR DEATH.

WARNING

ONLY THOSE PROFESSIONALS TRAINED AND QUALIFIED ON ELECTRICAL DISTRIBUTION SWITCHBOARDS SHOULD INSTALL AND/OR SERVICE THIS EQUIPMENT.

Extreme hazards can exist when energizing electrical distribution equipment and switchboards. Take all precautions necessary to protect people and property when energizing the equipment. Short circuits and ground faults may exist as a result from inadequate installation. Short circuits and ground faults within the switchboard can cause catastrophic damage, injury, and death.

1. Prior to energizing the switchboard, turn OFF all overcurrent devices and loads internal to the switchboard plus mains in downstream equipment.
2. Verify phase sequencing on loads, such as motors, which can be damaged or destroyed by incorrect phase connections.
3. If provided, use remote operators to close and energize switchboard, overcurrent devices, and loads.
4. Beginning with the main(s), turn ON each overcurrent device.

Maintenance

It is essential to maintain the equipment in satisfactory condition.

To ensure continued quality service, a systematic maintenance schedule is vital. Facility operation and local conditions vary to such an extent that the schedule must be prepared to suit the conditions. The maintenance schedule for individual devices, such as circuit breakers, meters, fusible switches, and so on, should be based upon recommendations contained in the individual instruction leaflet for each device. Inspection and test operations should be coordinated with an overall testing program to result in the least operating inconvenience and system shutdowns.

DANGER

HAZARDOUS VOLTAGE WILL CAUSE SEVERE INJURY OR DEATH. DE-ENERGIZE SWITCHBOARD PRIOR TO SERVICING.

WARNING

ONLY THOSE PROFESSIONALS TRAINED AND QUALIFIED ON ELECTRICAL DISTRIBUTION SWITCHBOARDS SHOULD INSTALL AND/OR SERVICE THIS EQUIPMENT.

Prior to performing any maintenance on the switchboard, first de-energize the switchboard at the source. Use lockout/tagout precautions as prescribed in OSHA, NFPA 70E, and other safety manuals.

The switchboard should be given a thorough maintenance check annually.

Exercise extreme care to prevent the equipment from being connected to the power source while tests are being conducted.

Switchboard insulation resistance testing

Maintenance before cleaning

Prior to cleaning, perform an initial Megger or DC test of the switchboard insulation, between phases and ground. Inspect for symptoms that may indicate overheating or weakened insulation. Record test readings. Refer to NEMA publication AB-4, *Guidelines for Inspection and Preventative Maintenance of Molded-Case Circuit Breakers Used in Commercial and Industrial Application*.

Prior to testing, remove all control power fusing and connections to products, which will be damaged in this test. This includes all components with control wire fusing, surge protective devices, metering equipment, and so on.

Switchboard insulation resistance testing

Maintenance after cleaning

After cleaning, perform a second Megger or DC test of the switchboard insulation between phases and ground.

Prior to testing, remove all control power fusing and connections to products, which will be damaged in this test. This includes all components with control wire fusing, transient voltage surge suppression, surge protective devices, metering equipment, and so on.

⚠ WARNING
TO PREVENT DAMAGE TO GROUND FAULT CONTROL CIRCUITS, METERING CIRCUITS, SURGE PROTECTIVE DEVICE (SPD), OR OTHER CONTROL CIRCUITS, WHEN MEGGERING SWITCHBOARD, ISOLATE CIRCUITS FROM SWITCHBOARD SYSTEM BEFORE BEGINNING THE MEGGER OPERATION. BE SURE TO RECONNECT THOSE CIRCUITS AFTER MEGGER TESTS ARE COMPLETED.
NOTE: SOME GROUND FAULT CIRCUITS MAY NOT BE FUSED; THEREFORE, ISOLATION OF THOSE CIRCUITS REQUIRES DISCONNECTING WIRING FROM BUS BARS.

⚠ WARNING
TO PREVENT DAMAGE TO GROUND FAULT CONTROL CIRCUITS, METERING CIRCUITS, SURGE PROTECTIVE DEVICE (SPD), OR OTHER CONTROL CIRCUITS, WHEN MEGGERING SWITCHBOARD, ISOLATE CIRCUITS FROM SWITCHBOARD SYSTEM BEFORE BEGINNING THE MEGGER OPERATION. BE SURE TO RECONNECT THOSE CIRCUITS AFTER MEGGER TESTS ARE COMPLETED.
NOTE: SOME GROUND FAULT CIRCUITS MAY NOT BE FUSED; THEREFORE, ISOLATION OF THOSE CIRCUITS REQUIRES DISCONNECTING WIRING FROM BUS BARS.

DO NOT USE AC dielectric testing.

DO NOT USE AC dielectric testing.

⚠ WARNING
DO NOT USE ALTERNATING CURRENT (AC) DIELECTRIC/ MEGGER TESTING. DAMAGE TO COMPONENTS WILL OCCUR.

⚠ WARNING
DO NOT USE ALTERNATING CURRENT (AC) DIELECTRIC/ MEGGER TESTING. DAMAGE TO COMPONENTS WILL OCCUR.

Cleaning

While the switchboard is de-energized, remove dust and debris from bus bars, connections, supports, and enclosure surfaces. A vacuum cleaner with a long nozzle will be of assistance. Wipe clean with a lint-free cloth. Do not use solvents to clean equipment, as damage to surfaces can occur.

Should the switchboard be exposed to adverse conditions, such as airborne contaminants, more frequent inspections and cleaning may be required.

A test resulting in readings at or above 1 megaohm is satisfactory. Compare these test readings with prior readings and retain with previous testing for future comparisons. Trends of lowered insulation resistance are signs of potential problems. A Switchboard Inspection Log form is provided in **Appendix B** to record readings.

Bus and cable connections

1. Inspect bus bar and cables for visible damage.
2. Visually inspect connections for overheating and damage.
3. All bus bar and cable connections should be checked and torqued in accordance with labeling on the switchboard. Refer to **Appendix A, Table 1** for torque values.
4. Inspect for broken wire strands and pinched or damaged insulation on cable connections.

⚠ WARNING
DO NOT USE COMPRESSED AIR TO CLEAN OR BLOW OUT DEBRIS OR DUST IN SWITCHBOARDS.

Insulation

All bus bar and structure insulation in the switchboard, including bus supports, bus shields, bus bracing, insulating barriers, and so on, should be visually checked for damage. Replace damaged parts. The life of insulation material is dependent on keeping the material dry and clean.

Do not use compressed air in cleaning. Use of compressed air to clean or blow out debris in switchboards may imbed the contaminants within overcurrent devices, metering equipment, and other components. Damage to insulation and other surface materials can occur.

Overcurrent devices

Maintenance instructions and field-testing for overcurrent devices are included with the instruction leaflet for each device within a family. One instruction leaflet per frame or family type was included with this installation booklet inside the switchboard. Refer to the leaflet on each device. If leaflets are missing, contact Eaton for replacement.

Circuit breakers

Visually inspect circuit breakers for signs of discoloration, cracking, scorching, overheating, or broken parts. Exercise the breaker operating mechanism, making sure it is opening and closing. A breaker showing signs of any one of these issues should be replaced. Refer to NEMA publication AB-4, *Guidelines for Inspection and Preventative Maintenance of Molded-Case Circuit Breakers Used in Commercial and Industrial Applications*.

Fusible overcurrent devices

Visually inspect the switching mechanism and fuse connections. Visually inspect the fusible devices for signs of discoloration, cracking, scorching, overheating, or broken parts. Replace any worn parts or the entire switch.

Fuse replacement

DANGER

HAZARDOUS VOLTAGE WILL CAUSE SEVERE INJURY OR DEATH. DE-ENERGIZE BOARD PRIOR TO SERVICING FUSIBLE DEVICES.

Be sure the switch mechanism is turned to the OFF position before attempting to remove fuses. Visually inspect the switch contacts, blades, and mechanism to ensure that the mechanism is in the OPEN/OFF position.

Check fuses to ensure that they are of the proper class, ampere, voltage, and interrupting rating. Ensure that non-current-limiting fuses are not used as replacements for current limiting fuses. Never attempt to defeat rejection mechanisms that are provided to prevent the installation of the incorrect class of fuse.

Meters, controllers, surge equipment, and other devices

Individual devices should be maintained according to the specific instructions supplied for each device. Remove dust and dirt from exterior with a dry lint-free cloth. Unless specifically instructed in the individual device instruction leaflet, do not attempt to open sealed cases or containers.

WARNING

NEVER USE COMPRESSED AIR TO CLEAN OR BLOW OUT DEBRIS OR DUST IN SWITCHBOARDS.

Secondary wiring

Check all wiring connections for tightness, including those at the current and potential transformers, if present, and at all terminal blocks. Check all secondary wiring connections to ensure that they are properly connected to the switchboard ground bus, where indicated. Look for broken wire strands and pinched or damaged insulation.

Ventilation

Check all grills and ventilation ports for obstructions and accumulations of dirt. Clean ventilation ports, if necessary. For switchboards installed outdoors, inspect the air space under the switchboard to be sure that it is clean and clear of debris, leaves, and obstructions.

Records

It is essential to maintain the equipment in satisfactory condition.

Maintain a permanent record of all maintenance activities and testing for future reference (see **Appendix B**).

The condition of each switchboard should be recorded as a guide for anticipating the need for any replacement parts or components or special attention at the next regular maintenance period. It is recommended that a series of inspections be made at quarterly intervals until the progressive effects of local conditions can be analyzed to determine a regular schedule.

Switchboard events and service interruptions

Short-circuits, ground faults, and overloads

WARNING

DO NOT ATTEMPT TO RE-ENERGIZE SWITCHBOARD OVERCURRENT DEVICES AFTER ELECTRICAL EVENTS, SUCH AS SHORT CIRCUITS, GROUND FAULTS, AND OVERLOADS, UNTIL THE CAUSE OF THE EVENT HAS BEEN IDENTIFIED AND CORRECTED.

A thorough assessment, identification, and correction of the event origin must be completed. An additional assessment of the conductor insulation and other insulating materials should be made. Replace all damaged insulation materials, conductors, and overcurrent devices. Original switchboard parts, insulators, insulation material, and overcurrent devices must be replaced with renewal parts from Eaton (see "Renewal parts," **page 18**).

Do not attempt to re-energize switchboard overcurrent components after electrical events, such as short circuits, ground faults, and overloads, until the cause of the event has been identified and corrected.

After the event has been rectified, test equipment per the maintenance process described in this publication.

Physical damage

Any physical damage to the switchboard that occurs after the switchboard is installed must be corrected. A thorough inspection, which includes the exterior enclosure and deadfront, plus interior components in the damaged portion of the switchboard, should be conducted. Replace all damaged parts and components. Ensure that there are no gaps in the switchboard enclosure that could cause exposure to live parts. Contact Eaton for renewal parts and assistance.

After the physical damage has been corrected, test equipment per the maintenance process described in this publication.

Effective July 2019

Water damage

⚠ DANGER

WET SWITCHBOARDS PRESENT A HAZARDOUS CONDITION AND MAY CAUSE INJURY OR DEATH. DE-ENERGIZE POWER TO ALL EQUIPMENT BEFORE SERVICING.

DO NOT WORK ON SURFACES OR FLOORS WHERE THERE IS STANDING WATER.

⚠ DANGER

DO NOT WORK ON SWITCHBOARDS OR ENTER AREAS THAT HAVE STANDING WATER. DE-ENERGIZE ALL EQUIPMENT IN AREAS WITH STANDING WATER.

DO NOT WORK ON WET ENERGIZED ELECTRICAL EQUIPMENT.

Major accumulation of water or moisture on any part of the switchboard can cause catastrophic damage to the switchboard. If a switchboard has been submerged by more than 2 inches or where running or standing water has had contact with current-carrying parts, it has sustained significant damage.

⚠ WARNING

SWITCHBOARD COMPONENTS, INCLUDING CIRCUIT BREAKERS, FUSIBLE SWITCHES, METERING, AND SO ON, SUBJECTED TO WATER OR MOISTURE MAY BE RENDERED UNSAFE. REPLACEMENT IS REQUIRED.

The switchboard and its components may be damaged beyond repair and may need replacement.

1. **Do not attempt to clean or repair water-damaged equipment or components.**
2. **De-energize the switchboard at its source.**
3. **Do not energize.**
4. **Contact Eaton for replacement.**

Minor accumulations of moisture, such as condensation, over a short period of time, may be corrected using heat.

De-energize switchboard.

Apply approximately 250 watts per vertical section for a sufficient period of time until the moisture disappears, then remove all heat sources and materials used for drying.

Inspect for damage to components and any corrosion. If any damage or corrosion is present, contact Eaton. **DO NOT RE-ENERGIZE SWITCHBOARD.**

After the switchboard has dried completely, remove all materials and tools from the equipment. Inspect all connections for damage and torque. Conduct switchboard insulation resistance testing described in this publication. Reinstall all covers.

Renewal parts

Switchboards can be complex assemblies with unique parts to fit the specific application and need. The manufacturer offers expertise with renewal part identification. To ensure safety and to maintain UL listing, it is essential that only new parts and components from Eaton be used.

When ordering renewal parts or when requesting information on the switchboard, it is essential to include as much information as possible.

Each switchboard will have a nameplate and other identification marks with details that will help expedite information requests and orders. The following may be required to help identify parts and information requests:

- GO or General Order Number
- Item number
- Description of the equipment
- Supply voltage
- Equipment ratings
- Catalog number or style number of part, if available
- Description of the part
- Drawing numbers
- Rating of part(s)

Electrical distribution equipment has a limited life span. As such, the manufacturer cannot guarantee the availability of obsolete equipment or parts. Equipment replacement may be recommended.

Appendices

Appendix A

Table 1. Torque values for copper or aluminum bus bar connections

Bolt size	Torque (lb in)	Torque (lb ft)
#10	30	2.5
1/4"	65	5.4
5/16"	130	10.8
3/8"	240	20.0
1/2"	600	50.0

Note: For other torque values, refer to the instruction leaflet for the specific component.

Appendix B

Switchboard maintenance, testing, and inspection logs

Refer to the "Maintenance" section of this document on **page 15** for detailed information.

DANGER

HAZARDOUS VOLTAGE WILL CAUSE SEVERE INJURY OR DEATH. DE-ENERGIZE BOARD PRIOR TO SERVICING FUSIBLE DEVICES. ONLY "QUALIFIED PERSONS" SHOULD INSTALL AND OR SERVICE THIS EQUIPMENT.

WARNING

TO PREVENT DAMAGE TO GROUND FAULT CONTROL CIRCUITS, METERING CIRCUITS, SURGE PROTECTIVE DEVICE (SPD), OR OTHER CONTROL CIRCUITS, WHEN MEGGERING SWITCHBOARD, ISOLATE CIRCUITS FROM SWITCHBOARD SYSTEM BEFORE BEGINNING THE MEGGER OPERATION. BE SURE TO RECONNECT THOSE CIRCUITS AFTER MEGGER TESTS ARE COMPLETED.

NOTE: SOME GROUND FAULT CIRCUITS MAY NOT BE FUSED; THEREFORE, ISOLATION OF THOSE CIRCUITS REQUIRES DISCONNECTING WIRING FROM BUS BARS.

WARNING

DO NOT USE ALTERNATING CURRENT (AC) DIELECTRIC/ MEGGER TESTING. DAMAGE TO COMPONENTS WILL OCCUR.

Table 2. Initial insulation resistance test record

Date	All overcurrent devices open						
	Phase-to-phase connections			Phase-to-ground connections			Neutral-ground connection
	A-B	A-C	B-C	A—Ground	B—Ground	C—Ground	

Date	All overcurrent devices closed						
	Phase-to-phase connections			Phase-to-ground connections			Neutral-ground connection
	A-B	A-C	B-C	A—Ground	B—Ground	C—Ground	

Notes:

Date	All overcurrent devices open						
	Phase-to-phase connections			Phase-to-ground connections			Neutral-ground connection
	A-B	A-C	B-C	A—Ground	B—Ground	C—Ground	

Date	All overcurrent devices closed						
	Phase-to-phase connections			Phase-to-ground connections			Neutral-ground connection
	A-B	A-C	B-C	A—Ground	B—Ground	C—Ground	

Notes:

Date	All overcurrent devices open						
	Phase-to-phase connections			Phase-to-ground connections			Neutral-ground connection
	A-B	A-C	B-C	A—Ground	B—Ground	C—Ground	

Date	All overcurrent devices closed						
	Phase-to-phase connections			Phase-to-ground connections			Neutral-ground connection
	A-B	A-C	B-C	A—Ground	B—Ground	C—Ground	

Notes:

Date	All overcurrent devices open						
	Phase-to-phase connections			Phase-to-ground connections			Neutral-ground connection
	A-B	A-C	B-C	A—Ground	B—Ground	C—Ground	

Date	All overcurrent devices closed						
	Phase-to-phase connections			Phase-to-ground connections			Neutral-ground connection
	A-B	A-C	B-C	A—Ground	B—Ground	C—Ground	

Notes:

Table 3. Switchboard inspection log

Date	Checklist	✓	Notes and actions taken
	Cleaning		
	Bus and cable connections		
	Insulation inspection		
	Overcurrent device inspection		
	Meters		
	Controllers		
	Surge protective devices		
	Other protective devices		
	Secondary/control wiring		
	Clean ventilation		

Date	Checklist	✓	Notes and actions taken
	Cleaning		
	Bus and cable connections		
	Insulation inspection		
	Overcurrent device inspection		
	Meters		
	Controllers		
	Surge protective devices		
	Other protective devices		
	Secondary/control wiring		
	Clean ventilation		

Date	Checklist	✓	Notes and actions taken
	Cleaning		
	Bus and cable connections		
	Insulation inspection		
	Overcurrent device inspection		
	Meters		
	Controllers		
	Surge protective devices		
	Other protective devices		
	Secondary/control wiring		
	Clean ventilation		

Note: Refer to the "Maintenance" section on **page 15**.

Eaton
1000 Eaton Boulevard
Cleveland, OH 44122
United States
Eaton.com

© 2019 Eaton
All Rights Reserved
Printed in USA
Publication No. MN015002EN / Z22981
July 2019



Eaton is a registered trademark.
All other trademarks are property
of their respective owners.