

# AutoVAR 300 automatically switched capacitor bank

## Installation, operation, and maintenance manual



### Contents

Description	Page
Installation overview . . . . .	2
Positioning . . . . .	4
Electrical system connections . . . . .	5
Controller setup procedure . . . . .	6
Startup and commissioning . . . . .	6
Controller setup procedure . . . . .	7
Troubleshooting . . . . .	11
Options . . . . .	13
Maintenance . . . . .	14
Drawings, major components, and spare parts list . . . . .	18



*Powering Business Worldwide*

**⚠ WARNING**  
FAILURE TO INSTALL THE AUTOVAR IN ACCORDANCE WITH THESE INSTRUCTIONS MAY CAUSE DAMAGE TO THE EQUIPMENT AND/OR PERSONAL INJURY.

**⚠ WARNING**  
INCOMING POWER SHOULD BE DISCONNECTED BEFORE MAKING ANY WIRING CONNECTIONS.

**⚠ WARNING**  
AFTER ALL RIGGING, SETTING, AND WIRING HAS BEEN COMPLETED AND BEFORE THE POWER TO THE AUTOVAR IS ENERGIZED, THE INTERIOR OF THE UNIT SHOULD BE CLEARED OF ANY METAL EQUIPMENT, METAL SHAVINGS, TOOLS, AND OTHER DEBRIS.

**⚠ WARNING**  
WHEN THE FRONT DOOR IS OPENED WITH THE MAIN DISCONNECTS CLOSED, THE POWER DISTRIBUTION BLOCKS, CAPACITOR FUSES, CAPACITOR CONTACTOR UPPER TERMINALS, AND CONTROL TRANSFORMER FUSES ARE ENERGIZED AT LINE VOLTAGE. ONLY QUALIFIED PERSONNEL SHOULD HAVE ACCESS TO THE CABINET INTERIOR.

**⚠ WARNING**  
AFTER DE-ENERGIZING THE UNIT, WAIT ONE (1) MINUTE BEFORE OPENING THE FRONT DOOR.

## Installation overview

The installation of the AutoVAR consists of the following steps:

1. Setting the cabinet(s) in place.
2. Connecting the assembly to the electrical system.
3. Installing the current transformer on the system (checking CT polarity) and terminating secondary in the unit.
4. Programming the controller.
5. Starting and ensuring proper operation.

## Current transformer installation instructions

**⚠ WARNING**  
FOLLOW ALL SAFETY PRECAUTIONS AND REGULATIONS FOR WORKING ON ELECTRICAL SYSTEMS RATED UP TO 600 V. ALWAYS WEAR APPROPRIATE PERSONAL PROTECTIVE EQUIPMENT (PPE). FOLLOW ALL LOCK-OUT TAG-OUT PROCEDURES.

**⚠ WARNING**  
FAILURE TO FOLLOW THESE INSTRUCTIONS CAN RESULT IN MALFUNCTION OF THE EQUIPMENT.

- A current transformer (CT) is required for operation of an automatically switched capacitor bank.  
If an order for the CT was placed on Eaton to supply a current transformer with the order, it is included within your unit. Unless specified otherwise, Eaton will supply our standard CT, which is a multi-ratio multi-tap split core CT rated from 300 A to 3000 A with 5 A secondary output and is rated for 600 V insulation class.  
If supplied, the low-voltage CTs are 600 V insulation class.
- The CT is to be installed on “A-phase” of the main service entrance and wired to the terminal block TB1, terminals 1 and 2 of the capacitor bank. See **Figure 3**.
- The CT should always be installed upstream of the loads and capacitor bank.
- CT shall not be installed on the feeder feeding the capacitor bank.
- CT polarity must be observed accurately for proper functioning of the capacitor bank. H1 should always face the source (utility) side. See **Figure 1**.
- CT rating determined by the mains service entrance rating. If exact rating is not available, select the next higher appropriate rating.
- If only the transformer rating is known, use the following formula to calculate the maximum current:

$$\text{Current for CT rating} = \frac{\text{transformer kVA} \times 1000}{1.732 \times \text{line voltage}}$$

**Table 1. Terminal connections for appropriate CT current rating**

CT secondary terminals	CT ampere rating
X1-X5	3000
X1-X4	2500
X1-X3	2200
X2-X5	2000
X2-X4	1500
X2-X3	1200
X1-X2	1000
X3-X5	800
X4-X5	500
X3-X4	300

The CT secondary rating for all the taps is 5 A. To calculate the CT ratio, use the CT primary ampere rating and divide by 5 to get the CT ratio.

For example, for X1-X5 the CT ratio is 600 (=3000/5).

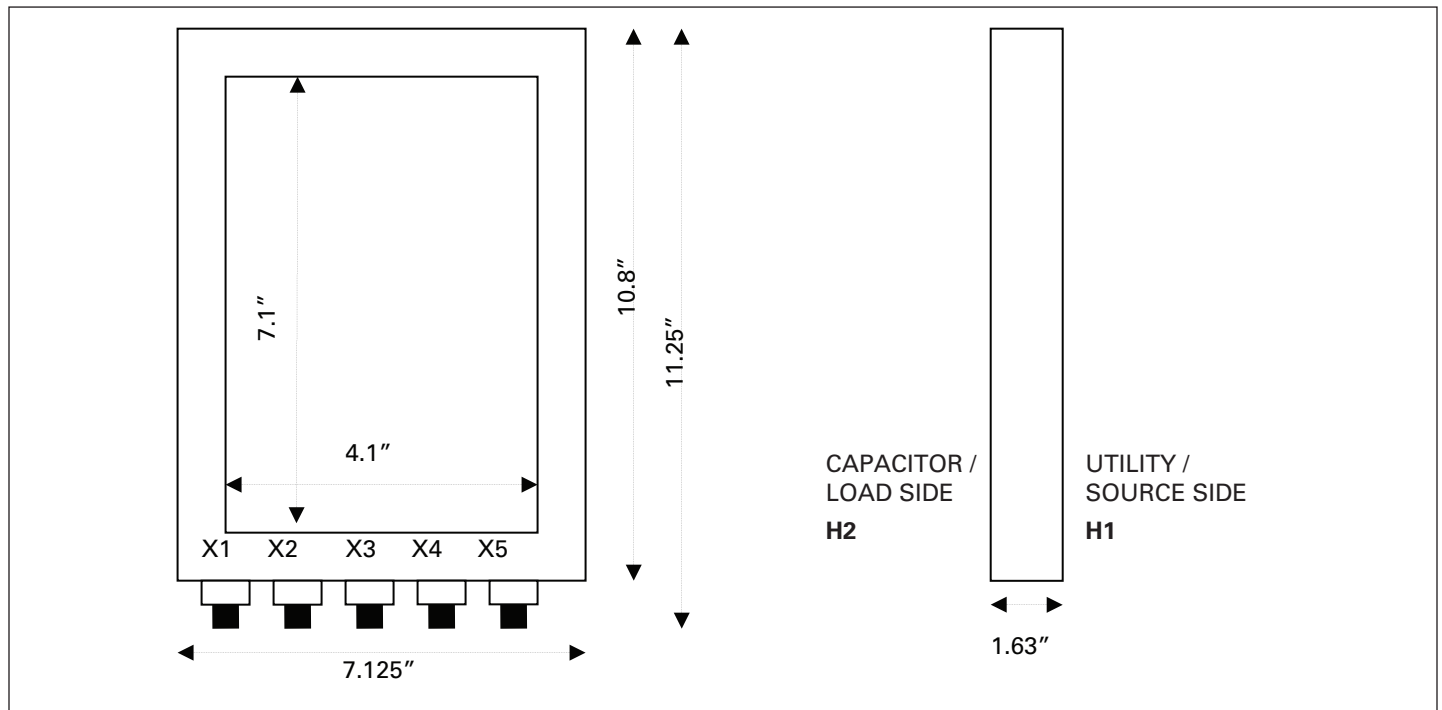
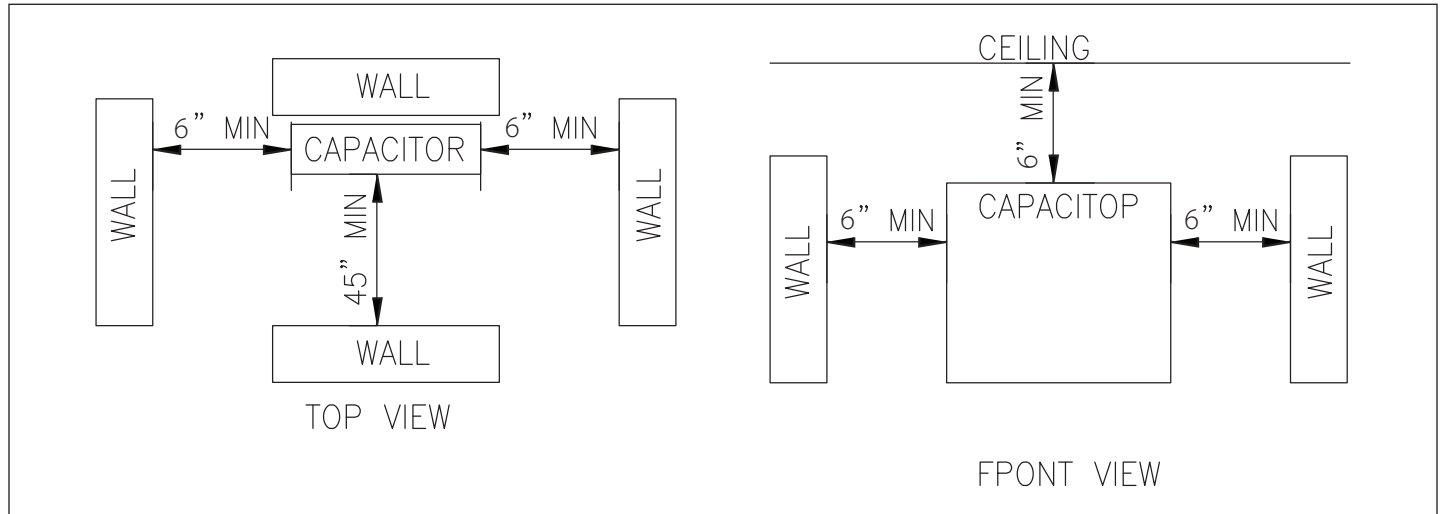

**Figure 1. CT placement schematic**

## Positioning

Position the unit so that:

1. Natural ventilation is not impeded.
2. Ambient temperature does not exceed 104 °F (40 °C).
3. Spacing complies with the National Electrical Code® (NEC®).



**Figure 2. Position of the unit**

**Note:** No more than three barriers, including the floor or overhead, shall restrict free air circulation when units are placed side by side. A minimum distance of 12 inches should be maintained between the two enclosures.

### Electrical system connections

When connecting the unit to the power system, the ground lug must be grounded and all applicable NEC codes must be followed.

The AutoVAR must be connected as shown in **Figure 3**. The lugs that accommodate the incoming conductors are located on the bus bars on the right side of the cabinet. If the unit is supplied with a disconnect, the incoming conductors are connected directly to the disconnect's line lugs. The lugs shall be torqued as indicated on these devices.

### Fused disconnects

Fused disconnects should be sized no less than 165% of the rated capacitor current.

### Circuit breaker

The circuit breaker should be sized no less than 135% of the rated capacitor current.

**Note:** Rated capacitor current =  $(1000 \times \text{kvar}) / (\sqrt{3} \times \text{voltage})$  (amps)

Where: Voltage = line-to-line voltage

kvar = Three-phase kvar rating of capacitor (nameplate rating)

Example: 500 kvar capacitor, 480 V system:

Rated capacitor current =  $(500 \times 1000) / (\sqrt{3} \times 480) = 601 \text{ A}$

The breaker shall be rated to carry the 601 A x 135% or 811 A continuously in its operating environment. In this case, therefore, a 1000 A 100% rated breaker will be required as a minimum.

### Conductor ampacity

NEC Article 460 specifies that the ampacity of capacitor conductors be rated at 135% of rated capacitor current. Our UL® listed units require that only 90 °C copper conductors be used at their 75 °C ampacity rating to supply the units. The ampacity should be derated as necessary for ambient temperature (see NEC).

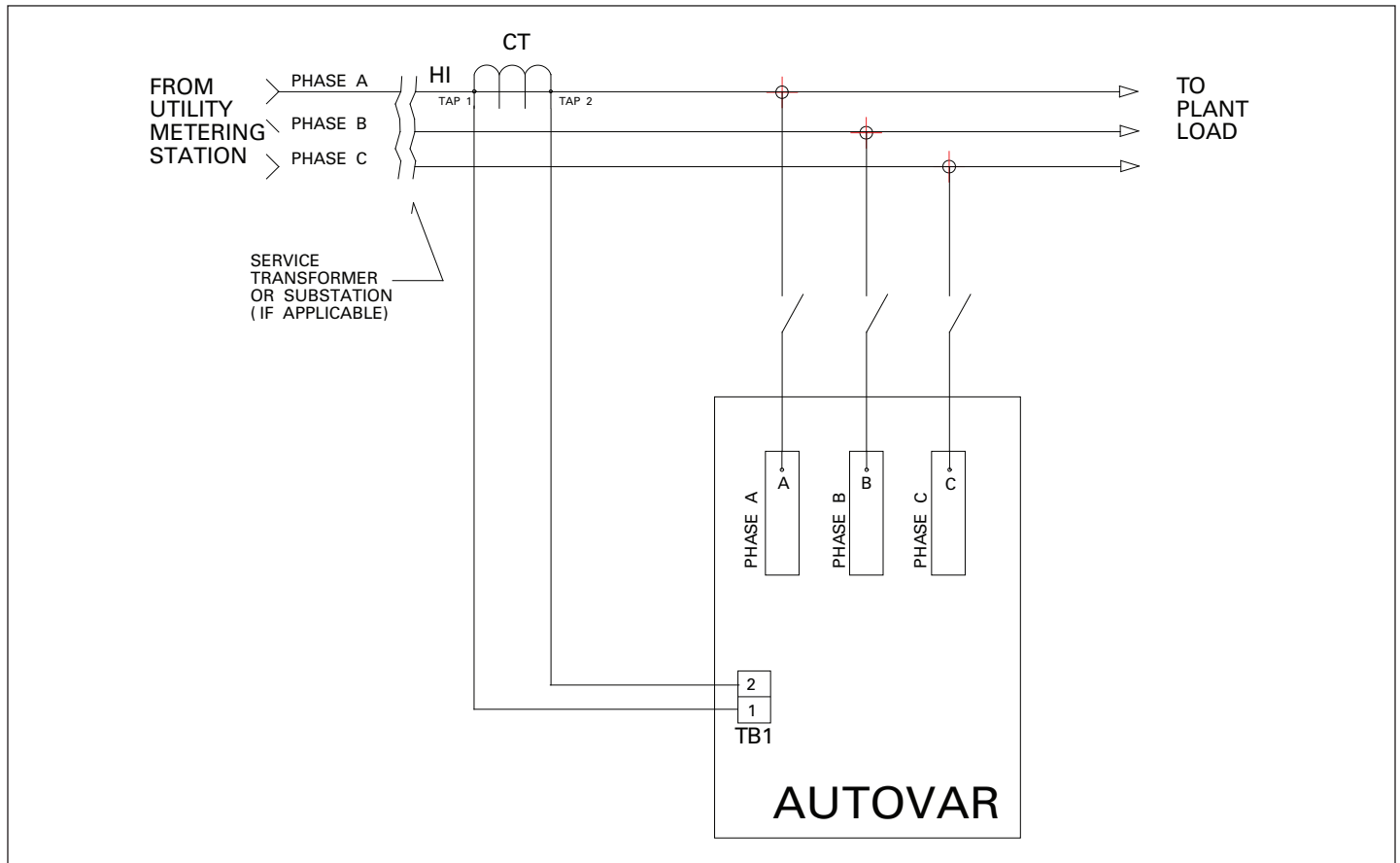

**Figure 3. Connection schematic**

**Note:** Refer to the CT tap setting, **Table 2**, on **page 6**.

## Controller setup procedure

### Current transformer placement and connection

**⚠ WARNING**

**THE CT TERMINALS MUST ALWAYS BE SHORT-CIRCUITED DURING INSTALLATION, REMOVAL, OR AT ANY OTHER TIME WHEN THE CT MAY BECOME OPEN CIRCUITED. THE CT IS SHORTED BY "JUMPERING" ANY TWO "X" TAPS OF THE CT TOGETHER. A CT SHORTING TERMINAL BLOCK (CAN BE PROVIDED AS OPTIONAL) MUST BE INSTALLED NEAR THE LOCATION OF THE CT.**

**A CT JUMPER MUST BE USED WITH ANY FUTURE ADJUSTMENTS TO THE CT OR ANY REMOVAL OF THE CT CONNECTIONS AT THE CONTROLLER.**

### CT tap setting

The CT is the current sensor required by the controller and is installed around the Service Entrance. The CT tap settings (CT ratio) therefore are to be selected so that it can handle the maximum load current that it will see. The easiest way to size the CT is to size it to the same ampacity as the service entrance rating.

If the maximum load current (MLC) of the plant is not known but the transformer kVA rating is known, then use the following formula:

$$\begin{aligned} \text{Maximum load current} &= (\text{kVA} \times 1000) / (\sqrt{3} \times \text{V}) && \text{(Amps)} \\ &= (\text{kVA} \times 577) / (\text{V}) && \text{(Amps)} \end{aligned}$$

Where: kVA = kVA of service transformer  
V = line-to-line voltage

Example: 480 V 1000 kVA entrance XFMR  
MLC = (1000 x 577)/480 = 1200 A

Once the maximum load current is known, the CT tap setting is determined by comparing the actual MLC to the values in the third column of **Table 2**. The taps corresponding to the closest higher value should be used.

**Table 2. CT tap setting**

**3000:5 Multi-ratio CT (039010-0006V)**

Tap 1	Tap 2	MLC amps: 5 amps (CT ratio)
X1	X5	3000:5
X1	X4	2500:5
X1	X3	2200:5
X2	X5	2000:5
X2	X4	1500:5
X2	X3	1200:5
X1	X2	1000:5
X3	X5	800:5
X4	X5	500:5
X3	X4	300:5

### CT placement

The placement of the CT is critical to the proper operation of the AutoVAR. **Improper location and phasing of the CT causes more startup problems than any other error.**

As shown in **Figure 3**, the CT must be placed upstream of the AutoVAR power connections preferably on phase A of the main incoming bus. In other words, place the CT so that it "sees" the *entire* plant load, including the AutoVAR and any other capacitors. The high side of the CT (marked "H1") must face the utility source.

After the CT has been placed on the main incoming bus, the interconnects from the CT secondary should be terminated on the terminal strip (TB) pins #1 and #2 (located on the inside left panel of the capacitor cabinet). The CT shorting strap may then be removed.

### CT cabling and connections

CT wires should be minimum #12 AWG up to 100 ft of wire length and #10 AWG up to 150 ft. CT wires will be routed separately than the power conductors and if not routed in a metal conduit, will be of shielded type cable. The length and gauge of wire is applicable for up to ANSI C57 B-0.5 burden. CT lead resistance will be kept to a minimum and calculated at expected overload capacity of up to 120%.

If CT signal is shared with other equipment, ensure that the VA burden does not exceed the CT accuracy requirement and CT leads first land on the PFC controller.

If the CT ratio does not accurately match the expected full load current, please contact the factory.

**The AutoVAR electrical connections are now complete.**

## Startup and commissioning

### ON/OFF switch

Ensure the ON/OFF switch located on the door is in the OFF position. The upstream or (optional integral) disconnect or circuit breaker can now be closed to energize the unit. Once energized, turn the ON/OFF switch to the ON position and the unit is ready to begin operation as indicated by the illuminated light within the ON/OFF switch.

### Blown fuse indicator lights

The indication lights on the door are blown fuse indicator lights that turn on when a power fuse inside the unit clears.

### Manual operation

Refer to the controller operation section on **page 7** for energizing the capacitor bank in manual mode.

**You are now ready to set the controller.**

## Controller setup procedure

Instructions henceforth are only applicable for the factory standard (default) controller. For Option C controller, please refer to the separately included instructions on Modbus enabled controller.

## Eaton BLR-CX Plus quick commissioning guide



Figure 4. Digital display

### Screen legends

INFO	Capacitor database
AUTO	Automatic mode
MANUAL	Manual mode
SETUP	Setup mode
ALARM	Blinking during alarm
NT	Second target-pf is active
EXPORT	Export of active energy
1-12	Capacitor stage number indication

## Operation

Operation of BLR-CX Plus is done by 4 keys.



Figure 5. Operational keys

Submenus are scrolled through by pushing the ▲ (up) key or ▼ (down) key.

Pressing ► (↵ right / Enter) key allows selection, entering the edit mode or accepts the edited values.

In edit mode, the ◀ (left / esc) key or ▶ (↵ right / Enter) key scroll left and right to allow setting of the appropriate digit.

Outside of edit mode, the ◀ (left / esc) key exits to the next higher level.

Press and hold the ◀ (left / esc) key for approximately 3 seconds to silence any alarms.

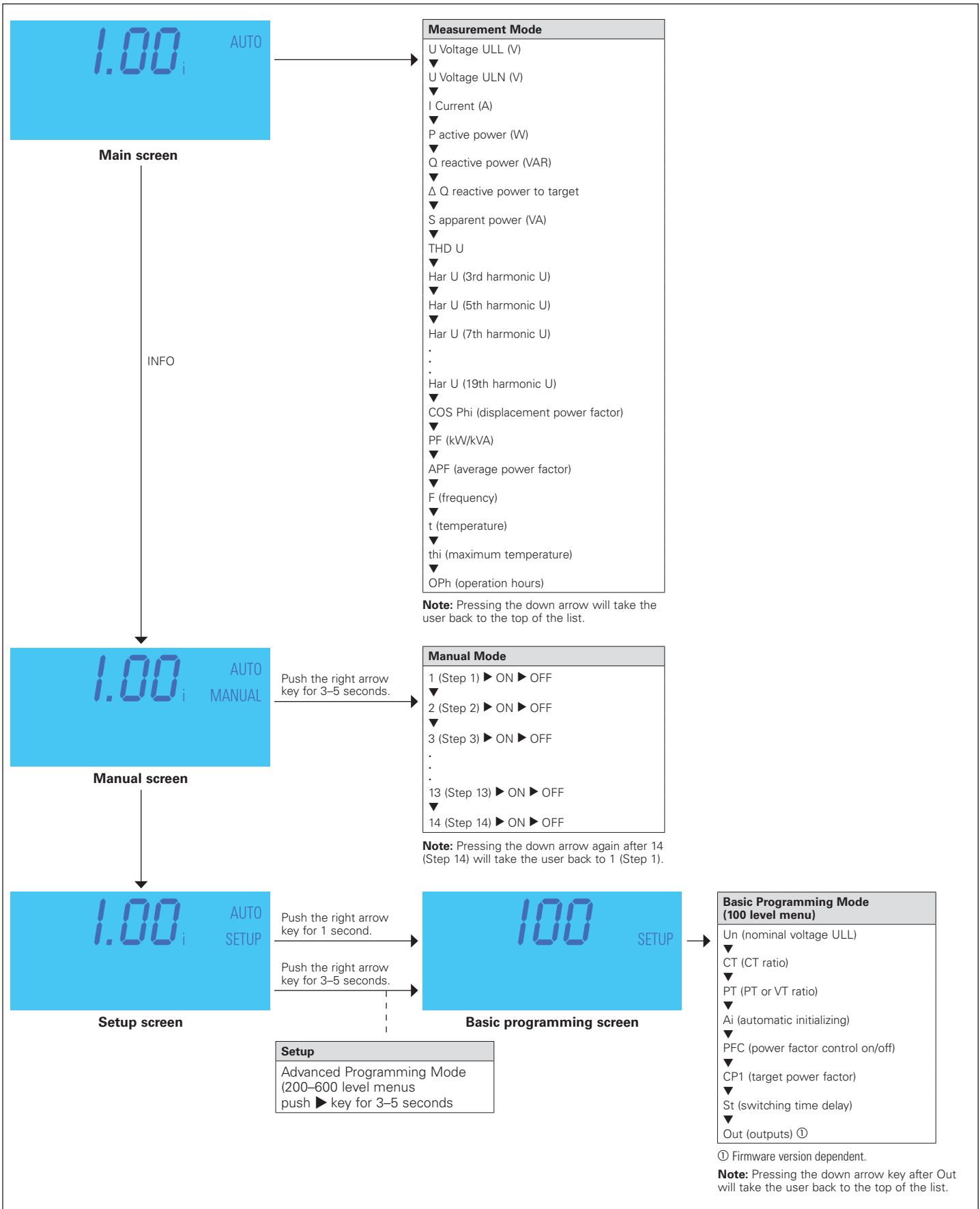

Figure 6. Menu map



## Programming the controller

### Step 1

**Upon power on the controller displays the existing power factor value "X.XX i" and enters the Automatic Control mode.**

The "i" at the end indicates an inductive power factor and would be appropriate for most installations. A "c" at the end indicates capacitive power factor and suggests reactive power export and may not be appropriate. Refer to the troubleshooting section for resolution steps.

### Step 2

Next step is to set up the basic parameters in the controller.

From the main screen, press the ▼ (down) key to step through the "INFO", "MANUAL" and to "SETUP" mode. When "SETUP" is shown, press the ► (↔ right /Enter) key to enter the Menu 100. Press the ► (↔ right /Enter) key and program and or verify the following values.

Un Nominal voltage (factory programmed, customer may verify)

**Ct CT-ratio (factory set to 600, which corresponds to 3000:5 current transformer ratio. Changing the CT ratio will change the capacitor step sizes in 402 and those values will have to be re-programmed.**

Pt PT-ratio (factory programmed)

Ai Start of automatic initialization (factory programmed)

PFC PF-control ON/OFF/ HOLD (factory programmed)

#### **CP1 Target-PF (customer to program)**

St Switching time delay (factory programmed, customer may verify)

Out Output type of each stage (Auto/Alarm/Fixed Off/Fixed On) (factory programmed, customer may verify)

Once the Menu 100 is programmed, press the ◀ (left / esc) key three times to return to the main screen that displays the existing PF.

## Overview

BLR-CX Plus is factory preset to the default values shown in **Table 3**. Customer to program and verify the values set to meet the specific conditions of each installation.

### Step 3

The next step is to verify the measured values.

From the main screen, press the ► (↔ right / Enter) key to enter the Measurement mode. See menu map for a list of designated parameters.

Press the ◀ (left / esc) key to return to the main screen that displays the existing PF.

### Step 4

The final programming step is to verify the working of the capacitor bank. This is done by activating the controller in manual control mode and cycling through all the available steps.

**Note:** The steps will switch on only after the factory set capacitor stage discharge time has elapsed.

After each manual operation of the stage, the PF should change in the right direction (for example, 0.70 i >> 0.78 i >> 0.85 i...).

If the PF changes in the right direction, the capacitor bank has been correctly commissioned. If not, please refer to the troubleshooting section.

To switch the controller in manual control mode, press the ▼ (down) key to step through the "INFO" mode to "MANUAL" mode. Press and hold the ► (↔ right /Enter) key for approximately 3 seconds until "1" displays, indicating the stage number 1 is available for control.

**Note:** In manual mode, the controller freezes the stages in their existing state (ON, OFF, or HOLD). Therefore, it is important to ensure that at the end of this Step 4, the controller is returned back to the automatic control mode by pressing the ◀ (left / esc) key to return to the main screen that displays the existing PF.

After activating all available steps, one should make note of the displayed PF value as that reading should be greater than or equal to the target PF desired. If the displayed PF with the electrical system fully loaded and all steps energized is less than the target PF, then the selected capacitor bank is not sized adequately to raise the PF to the desired value. The customer should either upgrade the capacity of the capacitor bank or the target PF value should be decreased to prevent "PF alarms".

**Menu structure**

The following table provides an overview about the basic and advanced programming parameters of BLR-CX Plus.

Menu 100 is the Basic Menu. Menu 200 through 800 is for advanced users only and requires a PIN access (242). The settings in these submenus should only be accessed and changed after consulting with Eaton. Menu 700 is Modbus setting menu. It is only available on capacitor banks with the “C” suffix.

**Table 3. Programming mode detailed menu map**

Menu	Function	Default	Customer settings
<b>100 Quick start setup</b>			
Un	Nominal voltage (phase-phase)	208 V / 240 V / 480 V / 600 V	
Ct	CT-Ratio	600 (corresponds to 3000:5 CT ratio)	
Pt	VT-ratio	1.7 (240 V unit) 3.7 (480 V unit) 4.7 (600 V unit)	
Ai	Start automatic initializing	N	
PFC	Start/Stop/Hold PF-control	On	
CP1	Target-PF 1	0.95i	
St	Switching time delay	60 s	
Out	Type of each step (1, 2, 3...12)	Auto (for each step installed in unit), Fixed Off (for unused controller outputs)	
<b>200 Setup measuring system</b>			
201	Nominal voltage (phase-phase)	208 V / 240 V / 480 V / 600 V	
202	CT-ratio	600 (corresponds to 3000:5 CT ratio)	
203	VT-ratio	1.7 (240 V unit) 3.7 (480 V unit) 4.7 (600 V unit)	
204	Tolerance nominal voltage	20%	
205	Voltage measuring	Y = L-L	
206	Phase-offset	90	
207	Start automatic initializing	N	
208	Synchronization to frequency	60 (60 Hz unit)	
209	Temperature offset	0 °C	
<b>300 Setup control system</b>			
301	Switching threshold	55%	
302	Target-PF 1	0.95i	
303	Target-PF 2	0.95i	
304	Target-PF 2 at KW-export	N	
305	Switching time delay	60 s	
306	Switching time delay for fine control	10 s	
307	Fine control active	N (for units with equal stage sizes), Y (for units with multiple stage sizes)	
308	Automatic Stage detection	N	
309	Block defective Capacitors	N	
310	Start/Stop/Hold PF-control	On	
311	Control algorithm	1	
312	Reactive-power offset	0	
313	Asymmetrical switching time delay	1	
314	Switch-off capacitors in leading condition	N	
315	Distribute sw. operations	N	
316	Detect faulty stages	Y	
<b>400 Setup capacitor database</b>			
401	Discharge time	60 s	
402	Capacitor size: step 1...max. 12	Varies (see equipment drawings for step size, typically 25, 50, or 100 kvar capacitive)	

Menu	Function	Default	Customer settings
<b>400 Setup capacitor database, continued</b>			
403	Type of exit: step 1...max. 12	Auto (for each step installed in unit), Fixed Off (for unused controller outputs)	
404	Switching operations: step 1...max. 12	0	
405	Operations hours counter: step 1...max. 12	0 h	
406	Fan relay as stage output	N	
<b>500 Setup alarm system</b>			
501	Reset alarms manually	N	
502	THD-U threshold	6%	
503	Disconnect capacitors when THD >	N	
504	THD alarm delay	120 s	
505	Stop control if I=0	N	
506	Service alarm	N	
507	Max. operations per step	262 k	
508	Max. operation hours of BLR-ACX-V	65.5 k	
509	Max. operation hours per step	65.5 k	
510	THD-I threshold	20%	
511	Digital input logic	Y	
512	Temp. threshold level 1 (fan control, type of exit: AL)	40 °C	
513	Temp. threshold level 2, disconnect capacitors	55 °C	
514	Control alarm (target cannot be reached)	Y	
515	Faulty stages alarm	Y	
516	Stage power loss alarm	Y	
517	Flashing display	N	
518	Digital input function	CP2	
519	I-Low alarm suppr.	Y	
520	Switch off active stages if digital input alarm	N	
521	I-Low alarm	Y	
522	I-High alarm delay	10 s	
523	Switch-off interval	60 s	
<b>600 Reset</b>			
601	Reset to default values	N	
602	Reset capacitor database to default	N	
603	Reset operation hours	N	
604	Reset average PF	N	
605	Reset max. temperature	N	
606	Reset alarm	N	
607	Info firmware	—	
608	Change password	242	
609	Restart first setup	N	
<b>700 Modbus</b>			
—	Baud rate	19.2 k	
—	Parity and stop bits	EVEN	
—	Slave address	1	
<b>800 System</b>			
801	Backlight during commissioning mode	N	
802	Backlight delay time	0.25 h	

## Troubleshooting

### ⚠ CAUTION

**WHILE ATTEMPTING ANY TROUBLESHOOTING STEPS THAT REQUIRE ACCESS INTO THE CAPACITOR BANK, ALWAYS FOLLOW ALL SAFETY PRECAUTIONS AND REGULATIONS FOR WORKING ON ELECTRICAL SYSTEMS. ALWAYS WEAR PROPER PPE AND FOLLOW APPROPRIATE LOCK OUT AND TAG OUT PROCEDURES.**

### Automatic control mode

The controller should display status "Auto," which indicates that the controller is working in automatic mode. This is the desired mode of operation. If "Auto" is not displayed, then the power factor control is not working. Reasons for this are:

- Manual mode is active
- Control mode has been switched off
- Temperature is too high (if temperature input is provided)
- Current from the CT is less than 15 mA
- Voltage is out of range
- Harmonic level of voltage is too high

### Alarms and description

The controller has an extended alarm system. When an alarm is active, the sign ALARM in the display blinks and an error code is shown on the screen. Possible error codes are shown in the table below.

Alarm	Description
<i>U</i> ALARM	The measured voltage is out of the set tolerance.
<i>I LO</i> ALARM	Measuring current is less than 15 mA (please check CT signal and verify that CT shorting pin has been removed).
<i>I HI</i> ALARM	Measuring current is too high.
<i>PFC</i> ALARM	Target cannot be reached.
<i>HRU</i> ALARM	The set THD voltage threshold has been exceeded.
<i>HRRL</i> ALARM	The set THD current threshold has been exceeded.
<i>STEP</i> ALARM <i>FLTY</i> ALARM	One or more steps are defective. The defective steps are blinking together with the ALARM sign.
<i>SPL</i> ALARM <i>/II</i> ALARM	One or more steps have less than 70% of original size. Number of step and alarm text are blinking alternately.
<i>THI</i> ALARM	Over temperature alarm. Threshold level 2 exceeded. The steps will be switched-off step-by-step.
<i>OPH</i> ALARM	The set operating hours of the controller have been exceeded.
<i>OPC</i> ALARM <i>/II</i> ALARM	The maximum switching cycles threshold of at least one stage has been exceeded.
<i>OPH</i> ALARM <i>/II</i> ALARM	The set operating hours of at least one stage have been exceeded.
<i>AI/RBRT</i> ALARM	The Automatic initialization has been aborted due to an error. The control is switched off.

### Current and voltage monitoring

The controller is equipped with current and voltage monitoring to ensure it is within its operating parameters. The controller will show "I LO" alarm if there is no measured current or the magnitude sensed is less than 15 mA. If the current is greater than 6 A, the controller will show "I Hi alarm".

If either of these alarms are displayed, check the CT current path, verifying that the correct CT ratio is selected, the CT is in the correct position, and the current input and shorting jumpers at the terminal block are removed.

The allowed range of voltage depends on nominal voltage. When nominal voltage is out of range, "U Alarm" is shown. If this alarm is seen, then the setting of nominal voltage has to be adjusted. Nominal Voltage is measured and entered phase to phase.

### Capacitor stage database

A step fault ("STEP / FLTY") or step low ("SPL") alarm indicates problems with the sensed capacitor size. To check the capacitor stages, switch the controller into the INFO mode by pressing the ▼ (down) key. In the INFO submenu, by pressing the ▲ (up) or ▼ (down) key, the steps can be chosen and once the steps are indicated in the display, pressing the ► (↵) (right/enter) key displays the information for the selected steps.

CC C INFO	▼ INFO	▼ OC INFO	▼ i INFO
50 kvar ⓘ	99.9% ⓘ	10.12 k ⓘ	AUTO ⓘ
actual power of step	percentage actual to nominal power	number of operations	step type

It's possible to have capacitive steps as well as inductive steps. Ensure the steps show capacitive ("C") kvar.

### High temperature alarm

1. Replace dust filters (Catalog Number **AUTOVAR6FX8**).
2. Verify proper operation of fans.
3. Verify that measured ambient temperature does not exceed 40 °C (104 °F).
4. Check for external sources of heat such as direct sunlight.

### PFC alarm

Possible reasons could be:

1. Insufficient capacitance available or target PF set too high.
2. Capacitor stages deteriorated.
3. Capacitor stages sensed or set incorrectly (both in terms of type (inductive or capacitive) and value (100 kvar instead of 50 kvar).

### PF value incorrect, decreases as steps are added or shows X.XX "c"

1. CT polarity is incorrect.
2. CT leads are swapped.
3. CT is not mounted on A phase.

Adjust the Phase-Offset menu parameter according to the following chart.

CT installed phase (with respect to incoming AutoVAR bus)	CT polarity	Controller phase-offset
A	Straight	90
A	Reverse	270
B	Straight	330
B	Reverse	150
C	Straight	210
C	Reverse	30

**PF value shows unity or does not change even after steps are engaged**

1. Location of CT is incorrect. Ensure that the CT is connected electrically ahead of the capacitor bank (at the service entrance panel or switchgear) and is not connected on the feeder that supplies power to the capacitor bank.
2. Steps have failed.

**Incorrect measurement values**

1. Check that CT and PT ratios are programmed correctly in Menu 100.
2. Check that Nominal voltage is programmed correctly in Menu 100.

**Controller not switching on additional steps and does not reach target PF**

This usually happens when the amount of capacitance available does not match the amount of kvar required. This can happen especially in low load situations when the amount of kvar required is very low compared to the smallest available step size (for example, total kvar required is 12 kvar and the smallest step size available is 60 kvar). The controller will not bring on any step to prevent overcompensation.

1. Check that the sensed and programmed capacitor step sizes are set and match the actual value.
2. Check that the setting in 314 is set to N.
3. Check the amount of shortfall kvar (▲Q) in the measurement menu and program this value in menu 312.
4. If all above fails, one may need to install smaller kvar size steps to allow the controller to switch them during low demand.

**BLR-CX Plus controller technical data**

Description	Specification
Measuring and supply voltage	Connection: Single-phase Range: 90–550 Vac, 45–65 Hz Protection: Max. 6 A Power consumption: 6 VA Transformer factor: Adjustable 1.0 to 350.0
Current measurement	Connection: Single-phase Range: 5 mA–5 A Transformer factor: Adjustable 1 to 9600
Stage outputs Option -xxR	6 or 12 Stage outputs Type: Relay, normally-open, potential-free Supply: Common, max. 10 A Switch capacity per relay: 250 Vac / 5 A 400 Vac/ 1 A 48 Vdc / 1 A 110 Vdc / 0.2 A Type: Transistor, normally-open, open collector output Supply: Common, max. 1.2 A Switching capacity per transistor: 100 mA/8–48 Vdc
Temperature measurement	NTC: Under the housing cover Accuracy: ± 5 °C
Alarm output Default Option -nc	Type: Relay, normally-open, potential-free Switching capacity: 5 A / 250 Vac Type: Relay, normally-closed, potential-free Switching capacity: 5 A / 250 Vac
Digital input	Logic: Adjustable, high- or low-active Input signal: 90–250 Vac
Service Interface	For service purpose only
Modbus Default Option -MB	Unassembled protocol: Modbus-RTU Interface: RS-485 Common-mode range: –7 to +12 V Differential-mode range: –12 to +12 V Output current: –60 to +60 mA

**BLR-CX Plus controller technical data, continued**

Description	Specification
Ambient temperature	Operating: –20 to +70 °C Storing: –40 to +85 °C
Humidity	Range: 0 to 95 % Condensation: Not allowed
Overvoltage category	300 VLN / 519 VLL CAT III/519 V – 550 V CAT II Degree of contamination = 2
Standards	IEC 61010-1, IEC 61000 6-2, IEC 61000 6-4: Level B, IEC 61326-1, UL 61010
Compliance and listing	CE, c NRTL us (c UL us), EAC
Connections	Type: Screw terminals, pluggable Cross section: Max. 4 mm <sup>2</sup>
Housing	Front: Plastic housing (UL94 V-0) Back: Metal cover
Protection class	Front: IP41 Back: IP20
Weight	Approx. 0.6 kg
Dimensions	Device: H x B x T: 144 x 144 x 58 mm Cut-out: H x B: 138 (+0.5) x 138 (+0.5) mm

**Retrofit installations with BLR-CX Plus controller**

Please retain and follow all instructions and safety precautions during and after installation.

1. Compare voltage and current ratings of BLR-CX Plus with data of mains and installation.
2. Mount the relay in the control panel with the two mounting clips.
3. Connect protection GROUND to PE connection of metal case.
4. BLR-CX Plus is to be connected according to the wiring diagram.
5. Ensure that the short-link for CT input signal is removed.
6. Typical wiring diagram of the controller is shown below. This may not match the existing installation. Please consult Eaton for retrofitting this into existing Eaton capacitor banks.

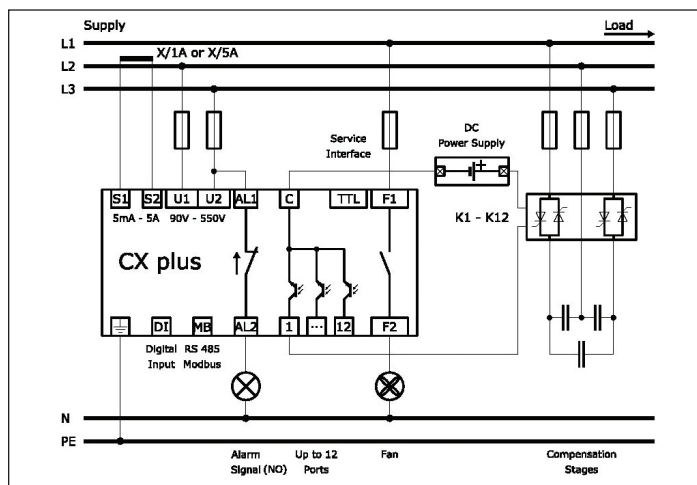

Figure 7. Connection diagram: CX plus— 12T

## Troubleshooting

Symptom	Correction
No control power	<p>Check primary control fuses (three fuses located in fuse holder) and secondary fuse located on control transformer.</p> <p>Check disconnect or circuit breaker is ON.</p> <p>Check GFCI located on control panel inside cabinet.</p> <p>Check the reactor thermal switches status (open if operated, closed if healthy).</p>
Displayed power factor is obviously wrong or decreases as stages engage	<p>CT secondary current is too low (check CT tap setting and plant load).</p> <p>CT polarity is incorrect or leads are reversed.</p>
Stages do not engage and target power factor has not been reached	<p>Confirm that an inductive power factor is being displayed (i.e., "i.73", not "c.73").</p> <p>Confirm that the required reactive power is at least 60% of the smallest step size available for switching.</p> <p>Confirm availability of capacitor stages and there is no stage alarm.</p> <p>Confirm "AUTO" is being displayed on the controller.</p>
Blown fuse lights on front cabinet are lit (with no blown fuses)	Check 3 primary control fuses (on control panel) if check system voltage matches the nameplate voltage.
Displayed power factor does not change as stages engage	Review "Current transformer placement and connection" section.
Controller troubleshooting	Refer to "Controller setup procedure" section.

### Fuse (clearing)

Capacitor fuses may clear for many reasons. An occasional cleared fuse may be the result of a switching 'spike', lightning strike, or other electrical disturbance. However, frequent fuse clearing may be a sign of a more serious problem. Please contact your Eaton representative or Eaton's Technical Resource Center at 1-800-809-2772, option 4, sub-option 2 for assistance if frequent fuse clearing occurs.

### Temperature control

The controller is fitted factory default with an ambient temperature alarm and trip option. The controller is also fitted with a non-reversing temperature sticker that helps monitor the highest reached temperature inside the cabinet.

The alarm and trip options are field adjustable and are set at the values shown in the controller set point table on **page 11**.

When the cabinet temperature exceeds the trip set point, the controller will stage wise shut down all the stages until the cabinet temperature falls below the trip set point, at point which the controller will resume the control of the stages.

If the PFC unit appears not to bring on any stages or is otherwise inoperable, check the temperature indicator on the back of the controller and verify that the temperature is within the specified limits of the unit.

## Options

### Remote alarm relay (option code A)

Remote alarm relay provides a single Normally Open volt-free 250 V / 5 A contact wired to a terminal block for customers' use.

### Communications controller (option code C)

Selecting option code C provides the user with our advanced controller that is equipped with Modbus® RTU RS-485 communications capability and additional advanced features.

### HOA switches (option code H)

The HOA switches provide external control of the capacitor stages. The following switch positions are available:

- Hand—turns stage on
- Off—turns stage off
- Auto—controller activated stages

### Circuit breaker (option code M)

The trip settings on the circuit breakers shall be set in accordance with the NEC and coordination requirements within the facility.

### IQ Meter (option code Q)

The IQ 250 Meter provides an electronic panel meter to those who wish to monitor various electrical parameters of the capacitor bank. The IQ Meter cannot display the system parameters and thus should not be used for displaying the system parameters such as power factor, power, voltage, current, etc. For operation of the IQ Meter, please refer to the IQ manual.

### Custom options (option code S)

Non-standard options including remote shutdown command, external interlock, etc. Consult with factory.

### Weather-resistant (option code W)

Allows the enclosure ingress protection rating to be NEMA 3R.

## Maintenance

The AutoVAR requires very little maintenance to operate reliably. However, please follow the Startup and Maintenance Schedule included.

**De-energize unit before withdrawing tray to access dust filter.**

### NOTICE

**IF ANY LARGE NONLINEAR LOADS (ADJUSTABLE SPEED DRIVES, VFDS, DC DRIVES, BATTERY CHARGERS, ETC.) ARE INSTALLED IN THE PLANT AFTER INSTALLATION, PLEASE CONTACT YOUR EATON SALES REPRESENTATIVE TO ENSURE THAT THE CAPACITOR WILL NOT BE ADVERSELY AFFECTED.**

Dust filters—Strata density panel air filters UL Class 2—  
1-inch x 28-inch x 8-inch.

The dust filter is located inside the door at the bottom.

**Dust filters should be replaced at least quarterly as suggested in our preventive maintenance guidelines and more often should the unit be located in a polluted environment.**

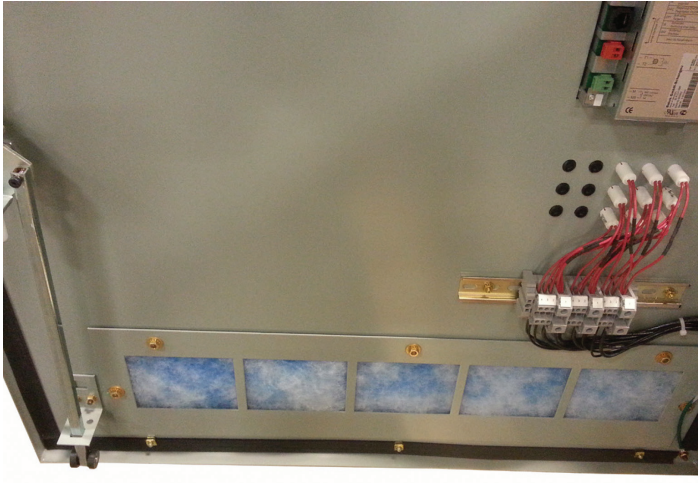

Figure 8. Dust filter location

Table 4. Low-voltage capacitor bank startup inspection and maintenance schedule

CUSTOMER:	UNIT SERIAL NUMBER:		P		Touch-up Paint		Service Schedule Years From Installation Date													
	C	F	Check for Open/Damage Fuse	R	Replace parts or component	15	12.5	10	7.5	5	2.5	5	7.5	10	12.5	15	17.5	20		
Qtr: Every 3 months Semi: Every 6 months Ann: Every 12 months	I	L	Inspection of Component/Equipment	S	Apply Silicone Caulk (Outdoor Unit)															
	O		Torque Connections	V	Verify Operation															
	Routine																			
Component	Start-up	Quarterly	Semi-Annually	Annually																
Date of Service:																				
Service Performed By:																				
Air Filters	I	R																		
Alarm Indication	V			V																
Bus Connections	O				O				O						O					O
Bushings	I				I,C															
Cable Terminations	O				I				O						O					O
Capacitor	I				I					T						T				T,R
Control & Timing Relays	V									T						T				T,R
Controller	V				V					T						T				T,R
Corrosion / Condensation	I				I,P															
CT Circuit	V				V															
Enclosure	I,S,P				I,P															S
Fans	V				I,V					T										R
Fuses	T				F															R
Insect Screens	I,C								C											C
Insulators and Supports	I,C				I,C															
Power & Control Cables	I				I															T
Reactor	I				I,C															T
Contactors	V				V															T
Test CT Polarity (optional)	T																			T,R

**Table 5. Low-voltage AutoVAR commissioning checklist**

**Note:** Form and photograph of installation must be completed and returned to Eaton Power Factor Correction Product Line (pfcwarranty@eaton.com) for activation of extended warranties, if purchased.

Project information	
Name of qualified individual	
Company name for qualified individual	
Customer name	
Customer location (city and state or province)	
Unit catalog number	
Unit general order number	
Unit serial number	
Current transformer information	
CT installation location (example switchboard main breaker)	
CT primary tap selected	A
CT secondary rating	A
CT ratio for controller (example 600 = 3000/5)	
Physical clearances for ventilation	Measured values
Top clearance (please specify units)	
Left side clearance (please specify units)	
Right side clearance (please specify units)	
Clearance between cabinets, if applicable (please specify units)	
Environmental considerations	
Installation type (indoor or outdoor)	
Measured ambient temperature, please specify C or F with measured value	
Sources of particulate buildup	
Sources of heat (e.g., direct sunlight)	

**Suggestion:** Attach a photograph of your installation here.



**Table 5. Low-voltage AUTOVAR commissioning checklist, continued**

<b>Inspection (for each item, please note 'Acceptable' or list any deficiencies)</b>	
Air filter(s)	
Bushings	
Capacitor cells	
Corrosion/condensation	
Enclosure	
Vents/screens	
Insulators and supports	
Power and control cables	
Reactor(s), applicable only to filtered units	
<b>Fastener torque</b>	
Bus connections	
Cable terminations	
<b>Testing</b>	
Control power fuses	
Contactors fuses	
CT ratio and polarity (test is optional)	
<b>Controller settings</b>	
System nominal voltage	V
CT ratio	
VT/PT ratio	
Automatic initialization (verify that this is set to No or Off)	
CP1 (Cos Phi 1)—target power factor, please specify number and I or C	
Switching time delay	
If CT ratio has been changed from factory default, have the capacitor step sizes in the 402 menu been re-set accordingly?	
If any modifications have been made to parameters in the advanced menus (with the exception of 402), please note the modifications	
<b>Verification</b>	
Does each contactor function properly during operation in the controller's manual mode?	
Does the power factor measured by the controller go in the correct direction when the contactors are closed in the manual mode?	
Does the voltage measured by the controller match the system voltage, within 10%?	
Does the current measured by the controller match the system current, within 10%?	
Does the controller show ALARM or EXPORT condition?	
Do the fans run?	
Do the push-to-test cleared fuse indicator lamps on the capacitor enclosure door glow brightly when pushed?	

## Drawings, major components, and spare parts list

Approximate dimensions in inches (mm).

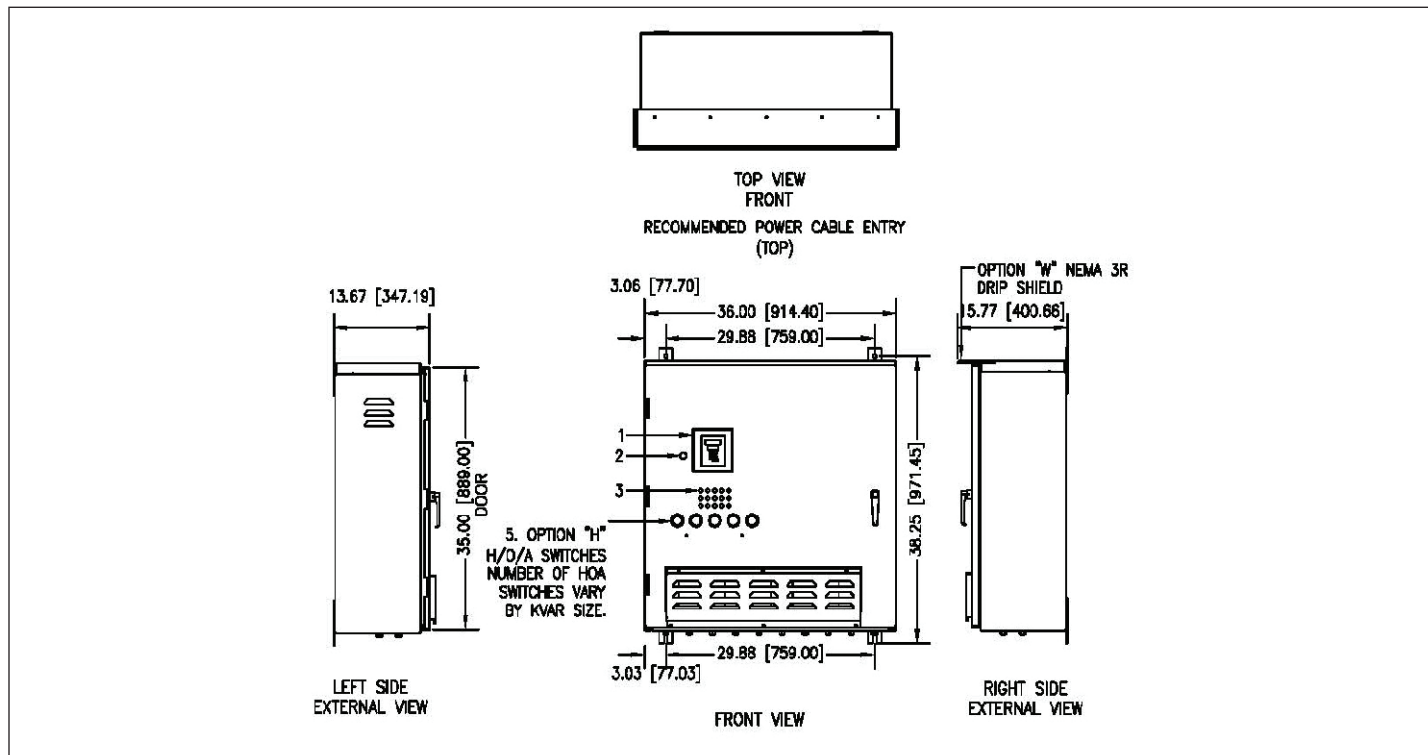

Figure 9. AutoVAR 300—Enclosure J, 36 inches

### Legend

1. Controller
2. ON/OFF switch
3. Blown fuse indicating lights
4. Circuit breaker
5. HOA (HAND/OFF/AUTO) switches

**AutoVAR 300 automatically  
switched capacitor bank  
Installation, operation, and maintenance manual**

This instruction manual is published solely for information purposes and should not be considered all-inclusive. If further information is required, you should consult an authorized Eaton sales representative.

The sale of the product shown in this literature is subject to the terms and conditions outlined in appropriate Eaton selling policies or other contractual agreement between the parties. This literature is not intended to and does not enlarge or add to any such contract. The sole source governing the rights and remedies of any purchaser of this equipment is the contract between the purchaser and Eaton.

**NO WARRANTIES, EXPRESSED OR IMPLIED, INCLUDING WARRANTIES OF FITNESS FOR A PARTICULAR PURPOSE OR MERCHANTABILITY, OR WARRANTIES ARISING FROM COURSE OF DEALING OR USAGE OF TRADE, ARE MADE REGARDING THE INFORMATION, RECOMMENDATIONS, AND DESCRIPTIONS CONTAINED HEREIN.** In no event will Eaton be responsible to the purchaser or user in contract, in tort (including negligence), strict liability or otherwise for any special, indirect, incidental or consequential damage or loss whatsoever, including but not limited to damage or loss of use of equipment, plant or power system, cost of capital, loss of power, additional expenses in the use of existing power facilities, or claims against the purchaser or user by its customers resulting from the use of the information, recommendations and description contained herein.

**Eaton**  
1000 Eaton Boulevard  
Cleveland, OH 44122  
United States  
Eaton.com

© 2019 Eaton  
All Rights Reserved  
Printed in USA  
Publication No. IM02607003E / Z23002  
July 2019



Eaton is a registered trademark.

All other trademarks are property  
of their respective owners.