

# Power Xpert Multi-Point Meter— high-density metering



## Introduction

Eaton's Power Xpert™ Multi-Point Meter is an ANSI C12.20 revenue class Web enabled electronic submetering device that can be mounted in panelboards, switchboards, or enclosures. When mounted in a panelboard or a switchboard, the Power Xpert Multi-Point Meter provides customers with an integrated power distribution and energy metering solution that saves space, reduces installation labor, and lowers total cost.

The Eaton Power Xpert Multi-Point Meter (PXMP Meter) offers a highly modular approach to high-density metering applications in electrical power distribution systems. The PXMP Meter is compatible with most three-phase industrial, commercial, and single-phase residential low voltage electrical power systems. The PXMP is equipped with two Modbus® RTU communication ports for local display and remote serial communications. The PXMP also has optional pulse input and digital output modules along with one standard digital output and three digital inputs. The PXMP Energy Portal Module is Web enabled, making it suitable for use with Ethernet networks and modems.

## Typical submetering applications

The Power Xpert Multi-Point Meter is ideally suited to handle submetering in low voltage power distribution equipment applications such as distribution boards in multi-tenant buildings, comprehensive main and feeder metering in commercial/industrial switchboards or medium voltage distribution equipment with the use of voltage and current transformers.

The Power Xpert Multi-Point Meter provides a cost-effective solution for residential or commercial metering installations. Typical installations include:

- High-rise buildings
- Government institutions
- K-12, universities and campuses
- Office buildings
- Medical facilities
- Apartment and condominium complexes
- Airports
- Shopping malls
- Industrial sites
- Mixed-use facilities

## Product description

The Power Xpert Multi-Point Meter can measure up to any of the following number of circuits:

- Sixty single-phase, two-wire (single-pole)
- Thirty single-phase, three-wire (two-pole)
- Twenty three-phase, four-wire (three-pole)

The circuits listed above can be mixed provided that the total number of current sensors does not exceed 60. The meter provides current; voltage; power factor; demand and active, reactive, and real power (VA, VAR, kW); and active, reactive, and real energy (VA, VAR, kWh) measurements for each load. The unit also provides up to two years at 15-minute intervals or eight years at one-hour intervals of demand data logging storage in non-volatile memory for up to 60 submeters.



Powering Business Worldwide

The Power Xpert Multi-Point Meter can be used with three different ratings of current sensors: 100 mA, 10 mA, or 333 mV. Switchboard/panelboard applications will use the 100 mA current sensors, which are highly accurate, self-protecting in the event of an open circuit condition under load and are supplied with an integral plug-in connector. The PXMP automatically detects the rating of the current sensor that is connected.

The PXMP can also use 10 mA current sensors that were previously installed for IQMESII retrofit applications. Additionally the PXMP can use 333 mV split core current sensors for retrofit applications where metering has not previously existed. The 10 mA and 333 mV current sensors are also self-protecting in the event of an open circuit condition under load.

## Features

- Monitors power and energy for up to 60 current sensors; space-saving modular design allows measurement from 1 to 60 circuits
- Built-in communication interfaces
- Monitors single-phase and three-phase loads from 120 to 600 Vac
- Monitors current, voltage, power factor, frequency, power, and energy
- Stores extensive energy profile data for each metering point; can be used to identify coincidental peak demand contribution
- LEDs provide status of unit communication activity and verify sensor connections
- Meets rigid ANSI C12.20 accuracy specifications for revenue meters
- Three standard digital inputs and eight pulse inputs per optional module to monitor WAGES (water, air, gas, electric, or steam)
- One standard digital output and eight digital outputs per optional module for alarm indication
- Three types of meter modules to support 10 mA, 100 mA, or 333 mV sensors
- Can be directly mounted in a UL Listed panelboard, switchboard, or enclosure
- 256 MB of memory in meter base for up to two years of 15-minute interval data (eight years of one-hour interval data) for eight demand values up to 60 submeters

## Communication capabilities

With the Power Xpert Multi-Point Meter's built-in communication capabilities, remote meter reading and monitoring functions can be integrated into both new and retrofit applications.

- Standard Modbus® RTU
- Optional Modbus TCP / BACnet/IP / SNMP / HTTP / SMTP / NTP / SFTP communications

## Software compatibility

The Power Xpert Multi-Point Meter:

- Can be used as part of an electrical energy monitoring and cost allocation system
- Can be remotely monitored via onboard Web pages with Eaton's optional Energy Portal Module
- Is compatible with third-party software platforms and interface devices

## Configuration

- The Power Xpert Multi-Point Meter is fully configurable using Power Xpert Multi-Point configuration software that can be downloaded free from the Eaton website at [www.eaton.com/meters](http://www.eaton.com/meters)
- Each Power Xpert Multi-Point Meter module can be configured for up to six metering points in any combination of single-phase and three-phase metering points corresponding to the voltage wiring of the meter base
- Power Xpert Multi-Point configuration software simplifies system commissioning and startup; PXMP configuration software supports both online and offline configurations

## Easy to install

- UL Listed for mounting inside panelboards (e.g., PRL4), switchboards, and NEMA 12 enclosures
- Quick connect terminals for current sensors, Modbus communications, and bus voltages make wiring the unit quick and easy

**Table 1. Features**

| Description   | Main/Aggregate      | Channel Data        | Tenant  |
|---|---------------------|---------------------|---------|
| <b>Instrumentation</b>                              |                     |                     |         |
| Current, per phase                                  | ■ ①                 | ■                   | —       |
| Voltage, per phase (L–L, L–N)                       | ■                   | ■                   | —       |
| Frequency   | —                   | ■                   | ■       |
| Minimum/maximum readings, V                         | Per phase           | —                   | —       |
| Minimum/maximum readings, W, VAR, VA                | Total and per phase | —                   | —       |
| Minimum/maximum readings, PF, F                     | Total               | —                   | —       |
| <b>Power</b>  |                     |                     |         |
| Real, reactive, and apparent power (W, VAR, VA)     | Total and per phase | Total and per phase | Total   |
| Power factor  | —                   | Average             | Average |
| <b>Demand</b>                                       |                     |                     |         |
| Block interval (fixed, sliding)                     | ■                   | —                   | —       |
| Real, reactive, and apparent power demand           | Total and per phase | —                   | —       |
| Minimum/maximum readings, PF, W, VAR, VA            | Total and per phase | Total               | —       |
| <b>Energy</b>                                       |                     |                     |         |
| Real, reactive, and apparent energy (Wh, VARh, VAh) | Total               | —                   | Total   |
| Real, forward and reverse, and total (Wh)           | ■                   | —                   | ■       |

① Main only.

**Mounting dimensions**

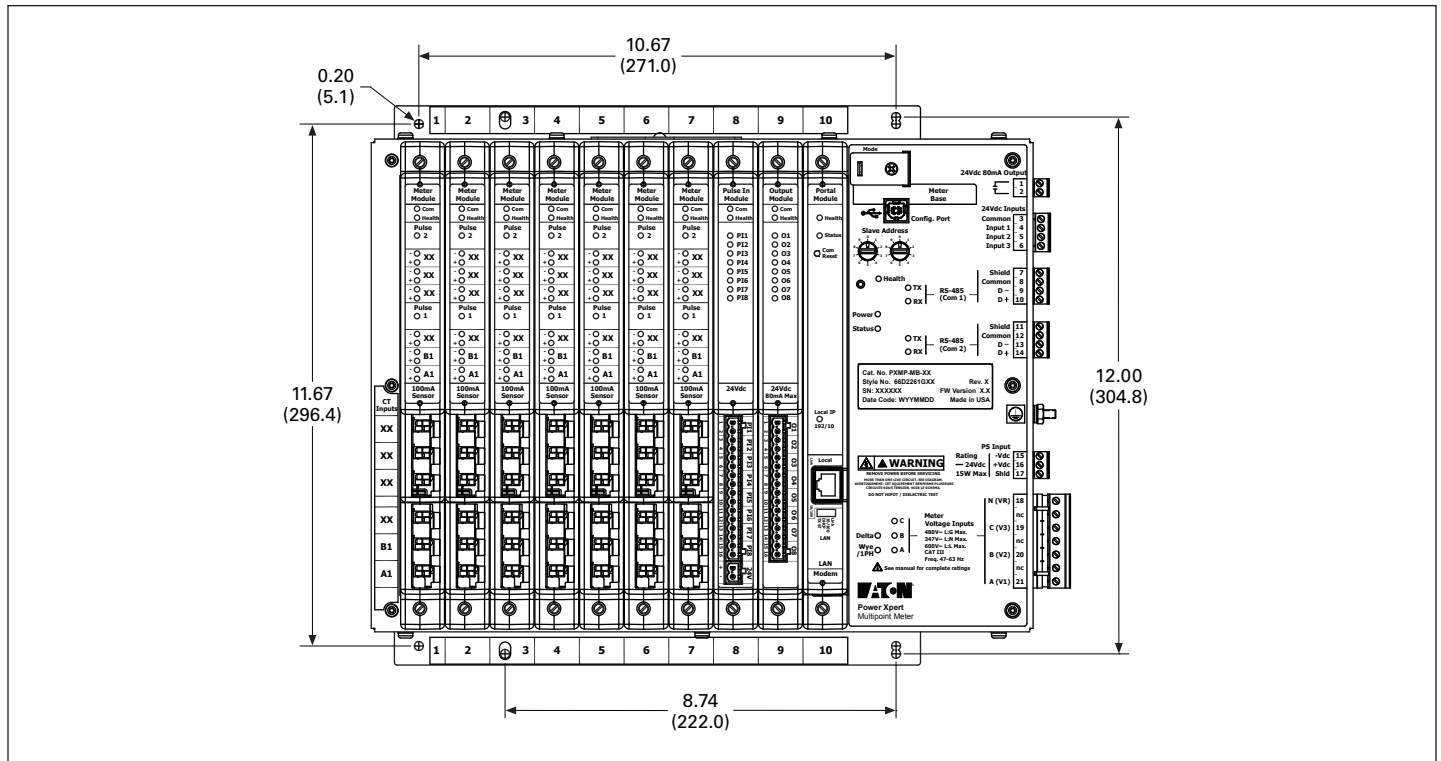

**Figure 1. Single Unit—Front View**

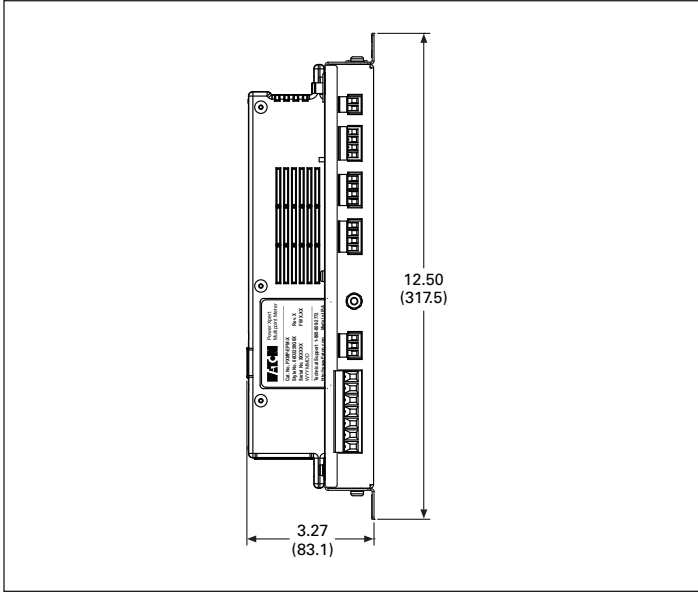

Figure 2. Single Unit—Side View

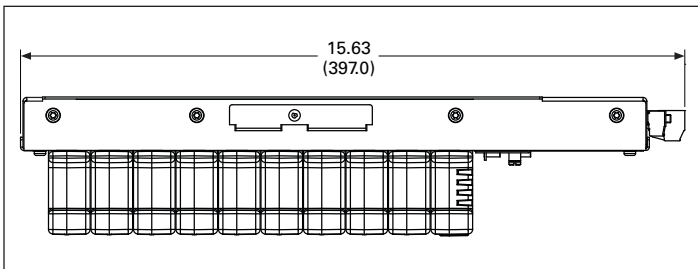

Figure 3. Single Unit—Top View

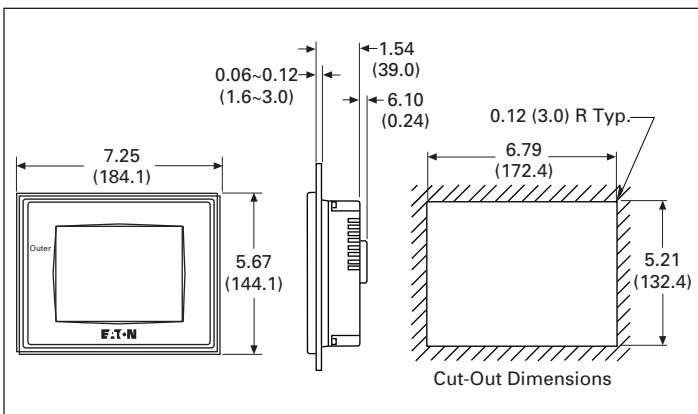

Figure 4. PXMP Color Touchscreen Display

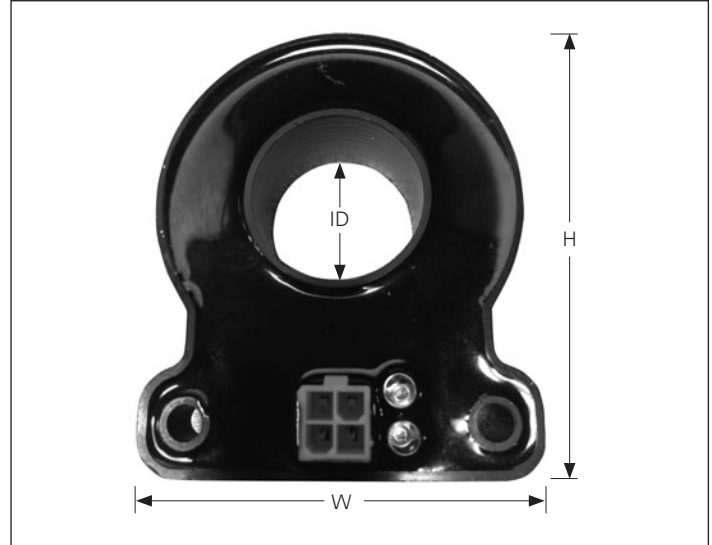

Figure 5. Current Sensor Dimensions

Table 2. Current Sensor Dimensions in Inches (mm)

| Sensor     | H           | W           | ID          |
|------------|-------------|-------------|-------------|
| PXMP-CS125 | 2.66 (67.6) | 1.66 (42.1) | 0.53 (13.5) |
| PXMP-CS250 | 2.96 (75.2) | 2.42 (61.5) | 1.12 (28.4) |
| PXMP-CS400 | 3.64 (92.5) | 3.03 (73.2) | 1.74 (44.2) |

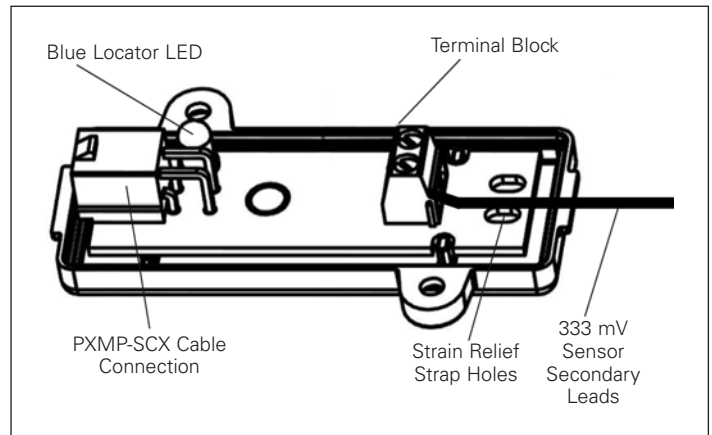

Figure 6. Open Interface Module (PXMP-IM333MV)

### Wiring for PXMB-MB

**Note:** For all voltage connections—Fuses should be sized in accordance with best practices to protect the instrumentation wire.

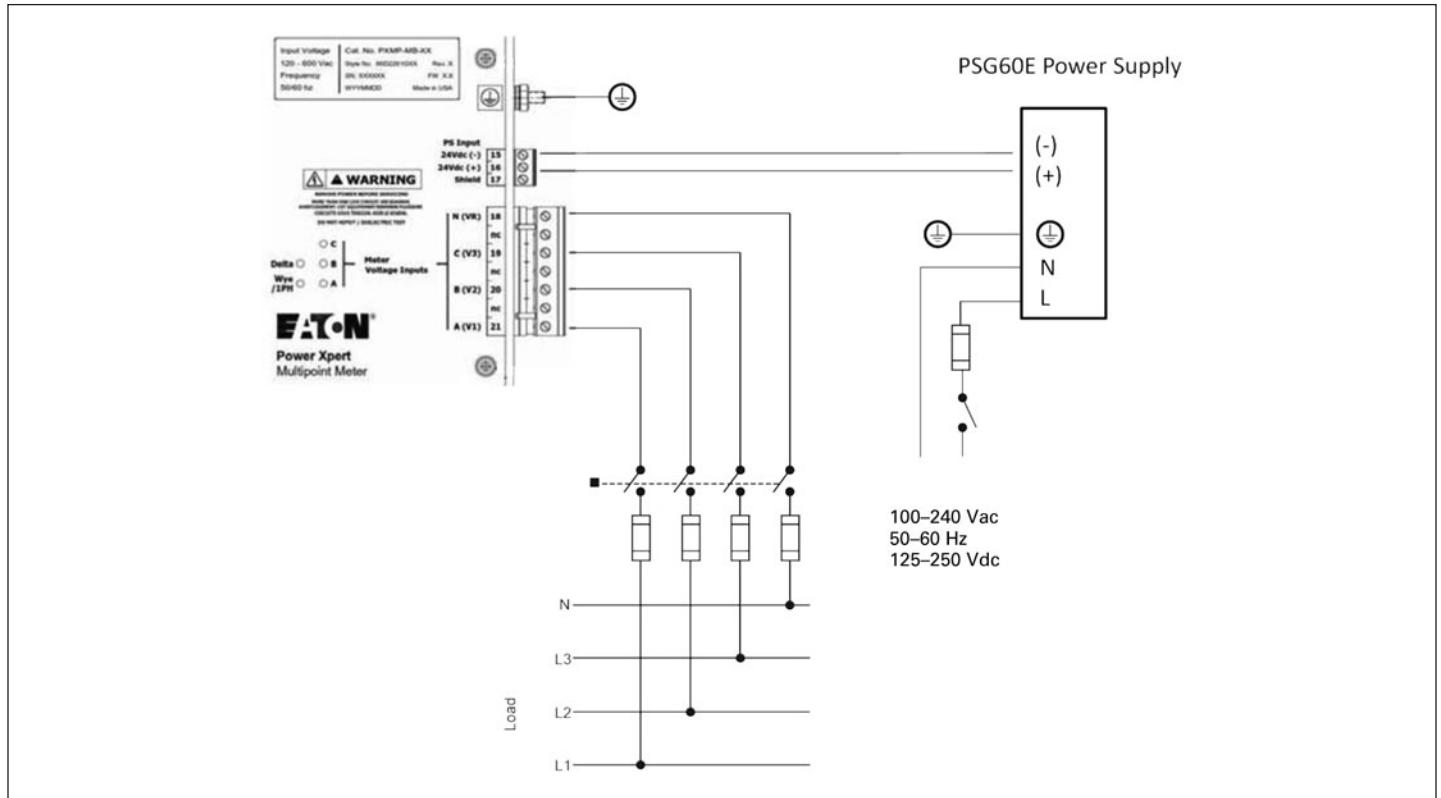

Figure 7. Four-Wire Wye Voltage Connection Inputs

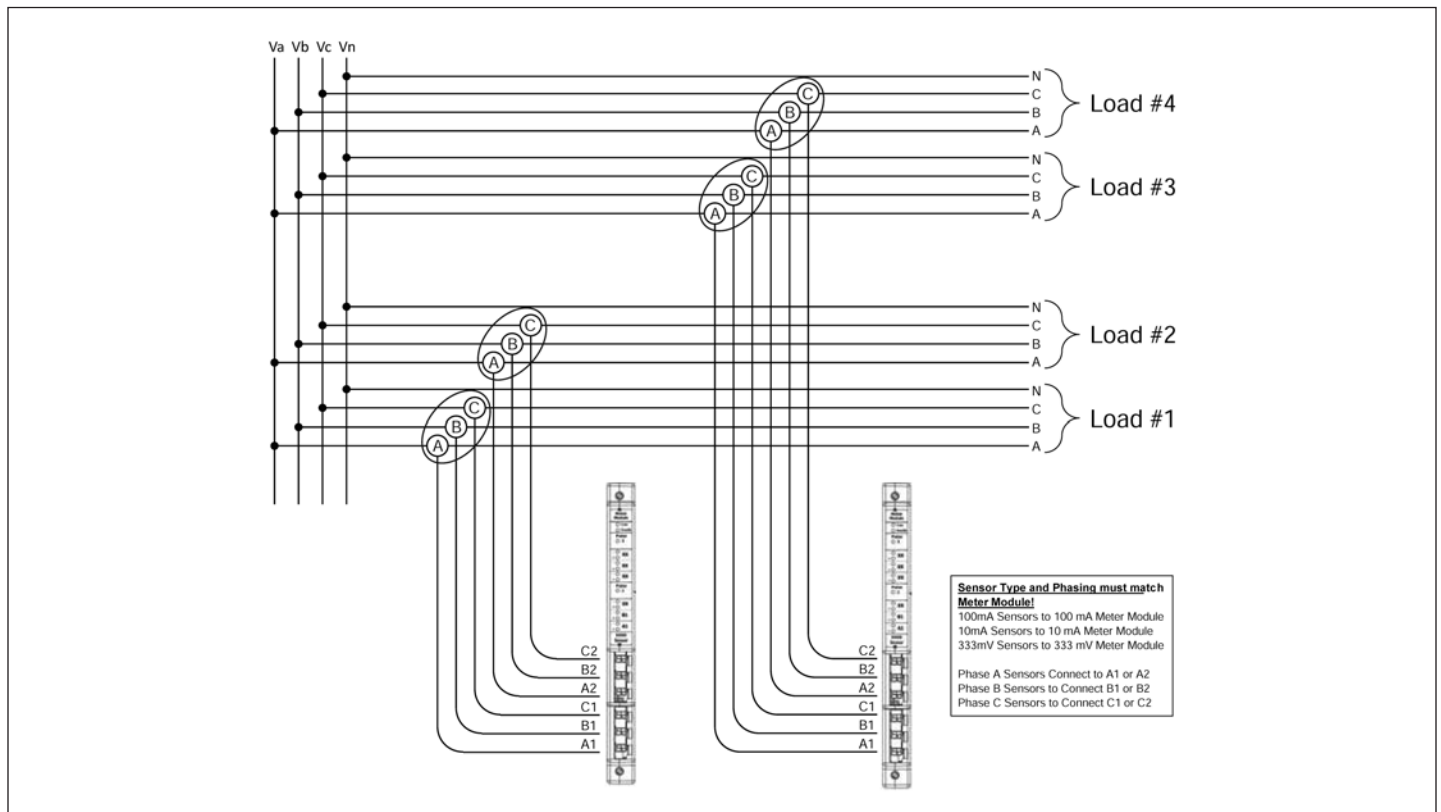

Figure 8. Three-Phase, Four-Wire Service Current Sensor Connections

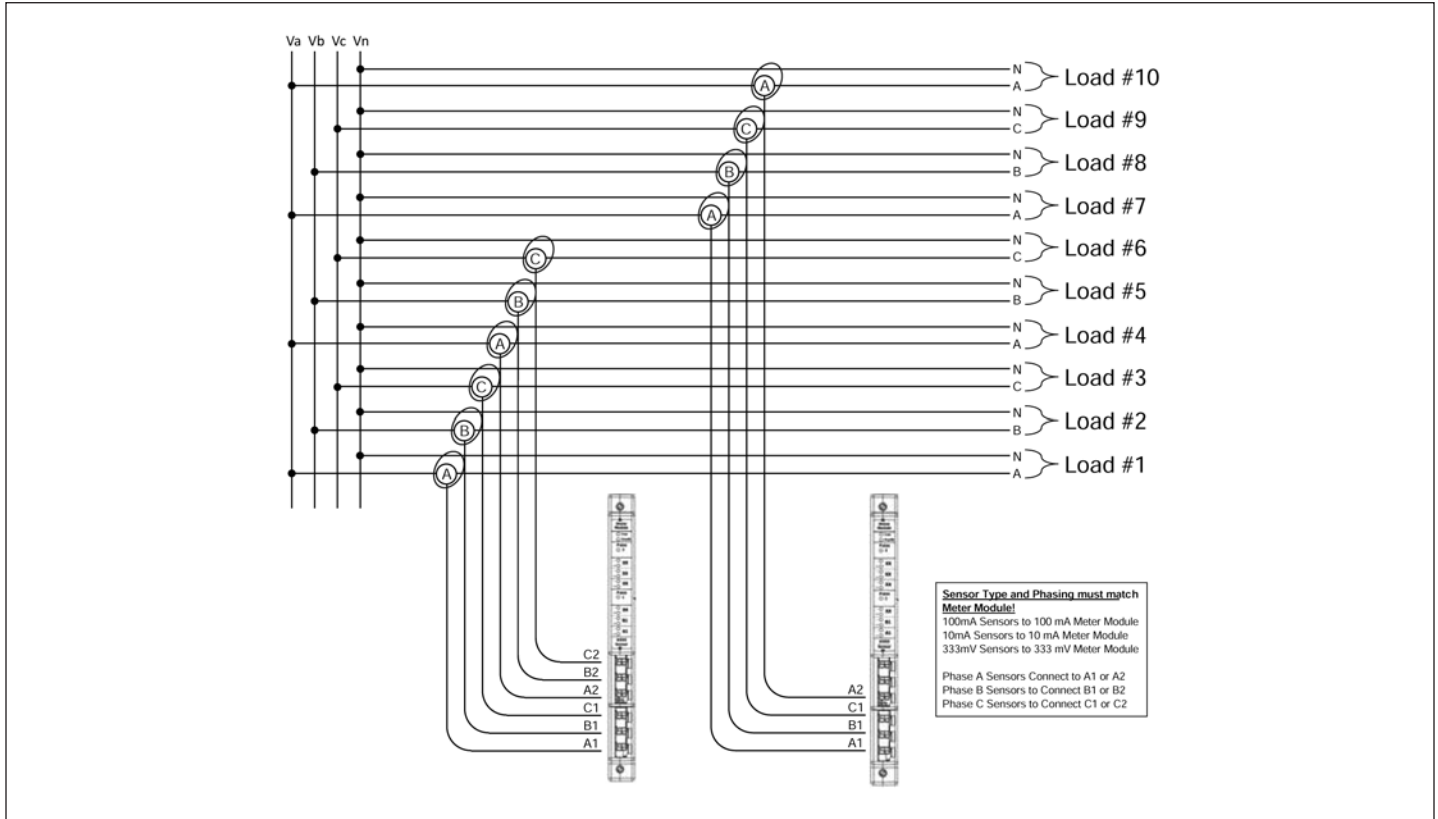

Figure 9. Three-Phase, Four-Wire Service (Ten Single-Phase, Single-Pole) Current Sensor Connections

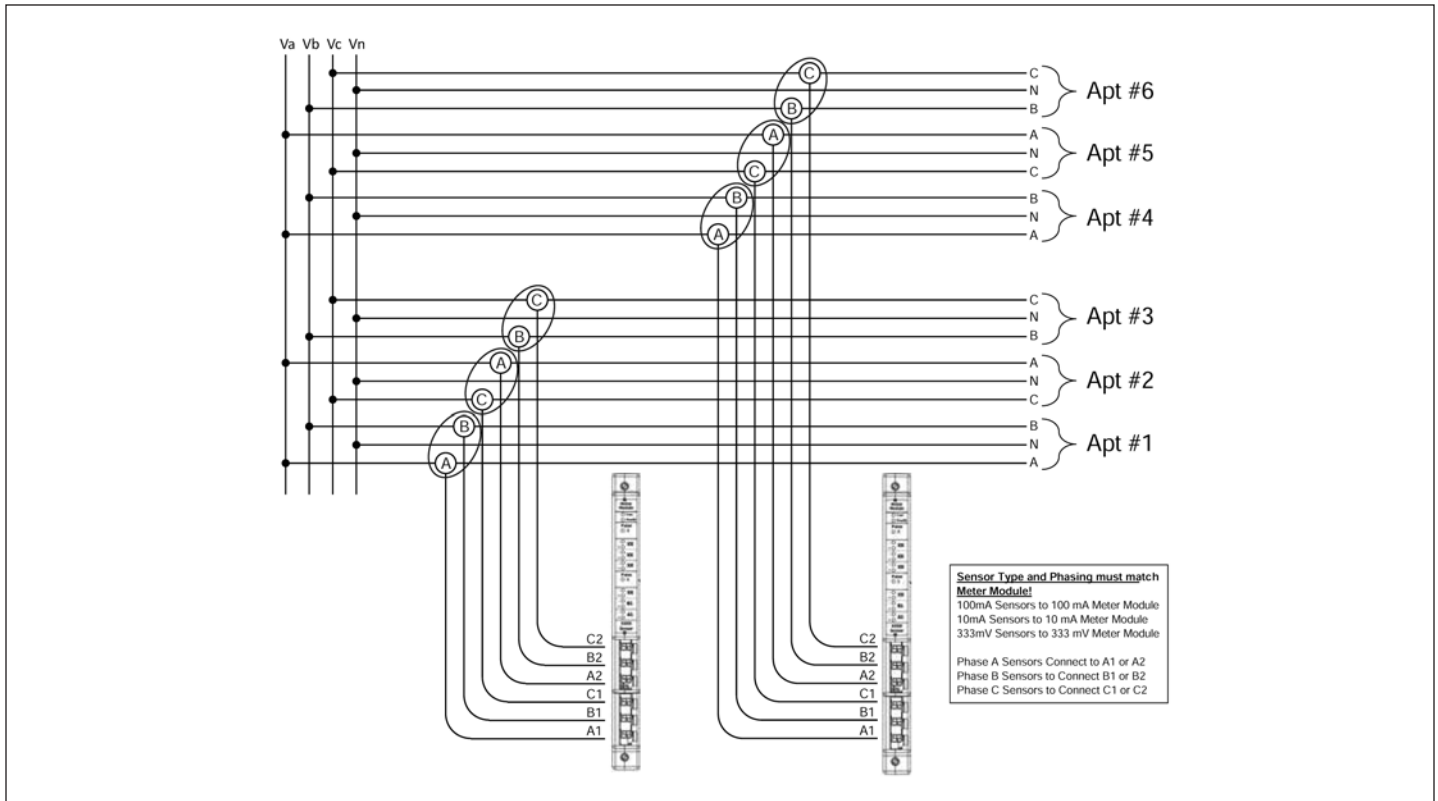

Figure 10. Network 120/208 Three-Wire Apartment Service Current Sensor Connections

### Wiring for PXMB-MB-AB

**Note:** For all voltage connections—Fuses should be sized in accordance with best practices to protect the instrumentation wire.

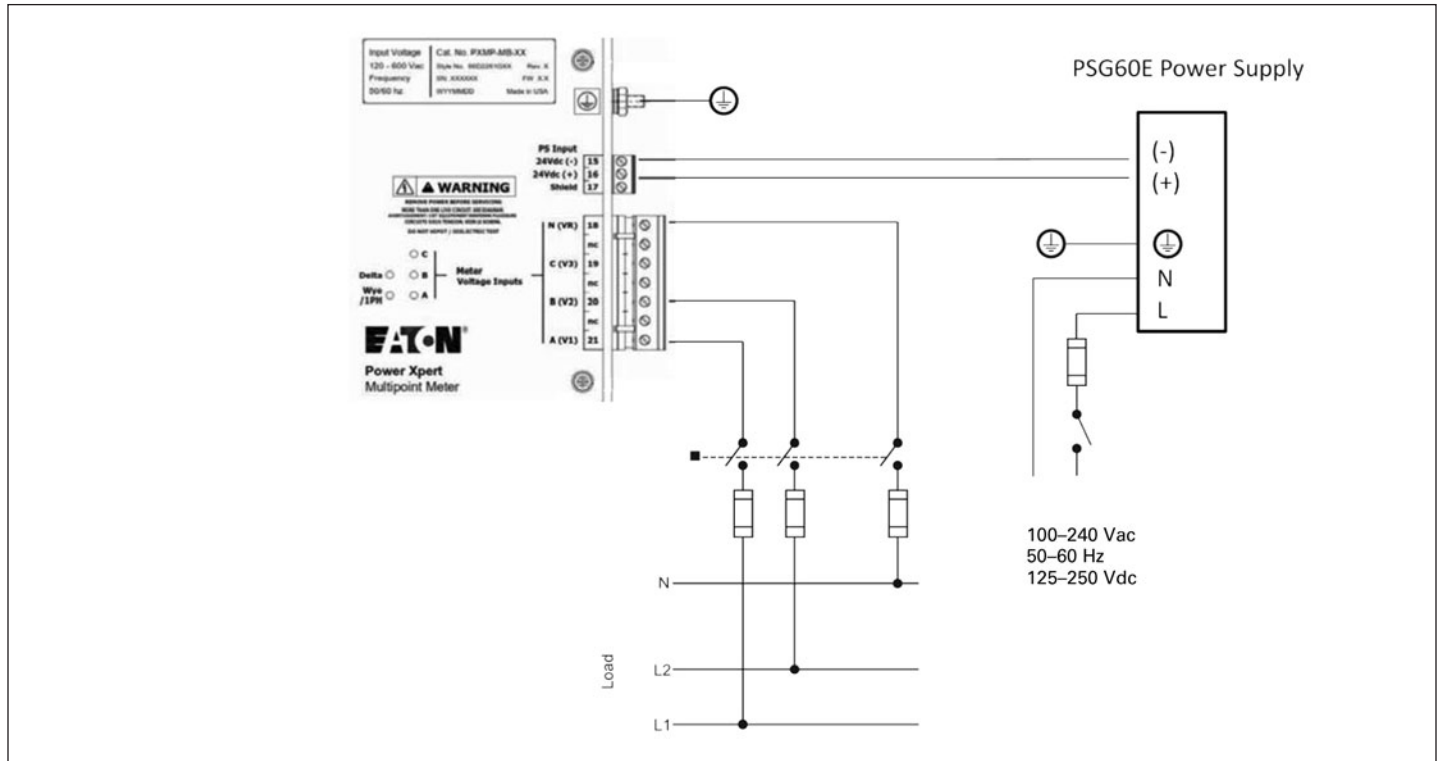

Figure 11. Single-Phase, Three-Wire 120/240 Voltage Connection Inputs

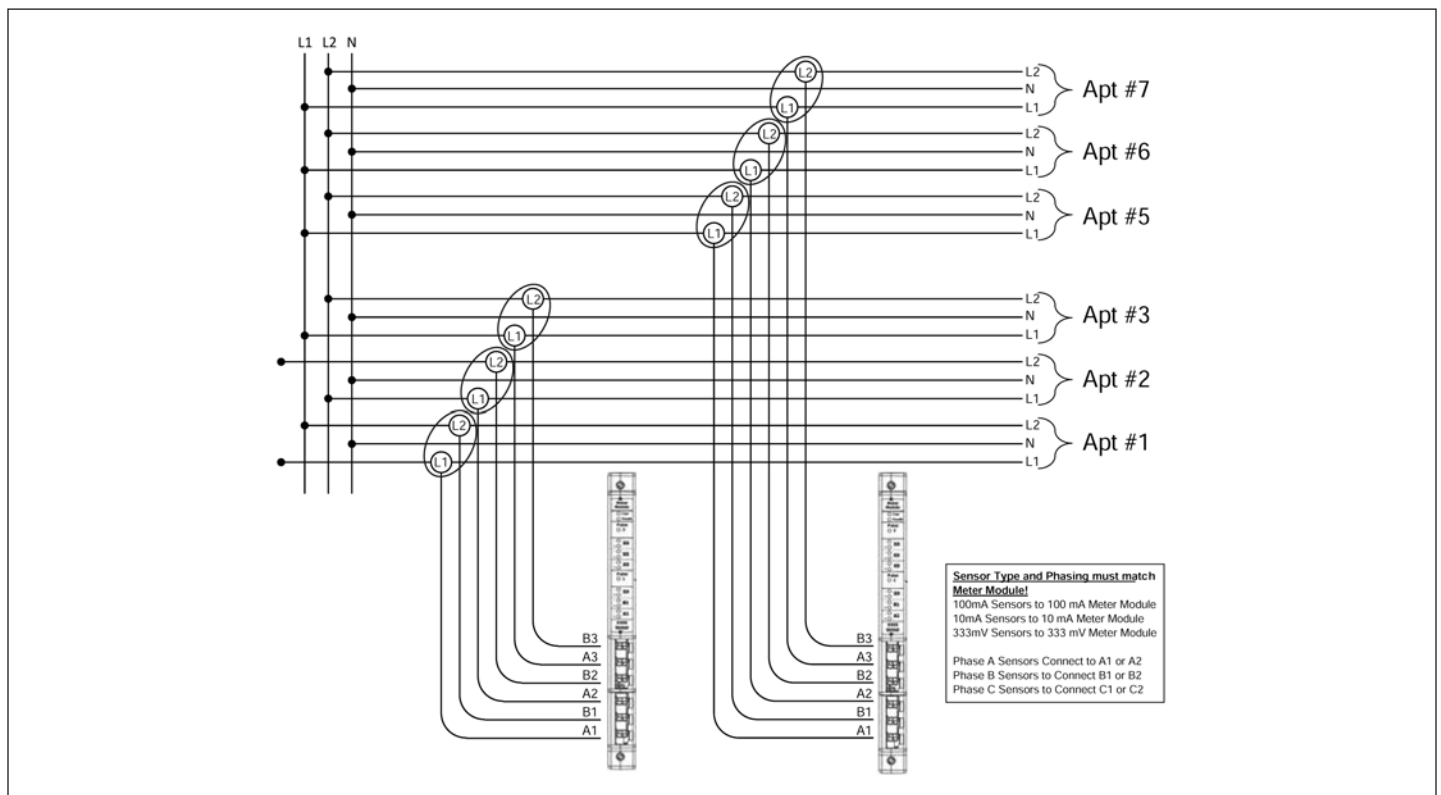

Figure 12. 120/240 Single-Phase, Three-Wire Service Current Sensor Connections

## Specifications

### Environmental

The PXMP Meter and current sensors must be housed in a NEMA or UL enclosure that keeps the internal environment within the PXMP's environmental specification ranges and provides suitable fire and mechanical protection in the end product installation.

- Temperature range: –20 to +70°C (–4 to +158°F)
- Storage temperature range: –40 to 85°C
- Humidity: 5–95% noncondensing environment
- Pollution degree: II
- Elevation: 0 to 9843 ft (0 to 3000m)
- Housing: IP20
- CE Mark
- EMC EN61326

### Emissions conducted and radiated

- FCC part 15 class B
- CISPR 11 class B

**Table 3. Electromagnetic Immunity**

| Standard     | Description               | Level |
|--------------|---------------------------|-------|
| EN61000-4-2  | ESD                       | 3     |
| EN61000-4-3  | RF radiated               | 3     |
| EN61000-4-4  | Electrical fast transient | 3     |
| EN61000-4-5  | Surge                     | 3 ①   |
| EN61000-4-6  | RF conducted              | 3     |
| EN61000-4-11 | Volt sag/swell/variation  | —     |

① 24 Vdc PXMP inputs are for a local bus that is surge level 2. PXG60E AC mains connection will support level 3.

### Product safety

- IEC/EN61010-1
- UL 61010-1 File E185559
- CNL evaluation to CAN/C22.2 No 1010.1.92

### Accuracy

- ANSI C12.20—Accuracy Class 0.5% with either CSXXX or PXMPCSXXX sensors
  - Measurement Canada Approval Pending

### External circuit group specifications

#### PXMP-MB (-AB) meter base

##### Discrete output

- Quantity 1—solid-state relay Form A NO Bidirectional FET
- Polarity of external source is not important
- Isolation circuit to ground 2 kV/1 min.
- Maximum external source voltage 28 Vdc
- Line-to-line TVS clamp across switching element at 32 Vdc
- Solid-state relay on resistance 35 ohms maximum
- Maximum load current 80 mA
- Minimum pulse width 20 milliseconds
- Fixed 25 milliseconds for pulse initiator function
- Maximum pulse rate 25 Hz
- Wiring to two-position removable terminal plug
  - 12–18 AWG (3.31–0.82 mm<sup>2</sup>), wire ferrules recommended
  - T1 (polarity not important)
  - T2 (polarity not important)

##### Discrete inputs

- Quantity 3, common circuits inputs 1–3
- Group isolation 2 kV
  - No input-to-input circuit isolation
- All inputs per module share a common external 24V (±10%) supply
  - 24V externally sourced between common and inputs
  - Design to interface with external dry contact
  - Input impedance ~2.2K ohms
  - Input current draw ~10 mA per input
- Minimum pulse width 10 milliseconds
- Maximum pulse rate 20 Hz
- Wiring to four-position removable terminal plug
  - 12–18 AWG (3.31–0.82 mm<sup>2</sup>), wire ferrules recommended
  - T3—Common (connect ext. 24 common here)
  - T4—Input 1 (dry contact to 24V hot)
  - T5—Input 2 (dry contact to 24V hot)
  - T6—Input 3 (dry contact to 24V hot)

#### COM1 and COM2 RS-485 serial ports

- No D+/D– biasing reliance on fail-safe driver and biasing at Master
- Baud rate configurable between 9600–115K baud (default)
- Use cable designed for RS-485 communications
  - Low L:L capacitance
  - Impedance of ~100–120 ohms
  - Shield—Mylar for high frequency; Braid for low frequency
  - Separate common and shield for best noise immunity
  - Maximum cable length is 4000 ft (1219.2m) with 32 nodes at 19.2K baud increased data rates will reduce maximum cable distance
  - 2000 ft (609.6m) with 32 total nodes at 115.2K baud
- Isolation 300V to ground due to TVS diode clamps
- Modbus RTU slave protocol, address defined by rotary switch



- Green Rx and Red Tx LEDs per channel
- Data + > Data—during idle marked, logic 1 state
- End of Line Termination resistance should match cable impedance (typ. 100–120 ohms)
- Four-position removable terminal plug 18–22 AWG (0.82–0.33 mm<sup>2</sup>) typical, wire ferrules recommended
  - COM1
    - T7—Shield
    - T8—RS-485 common
    - T9—Data –
    - T10—Data +
  - COM2
    - T11—Shield
    - T12—RS-485 common
    - T13—Data –
    - T14—Data +

#### PXMP-MB power supply input

- 24 Vdc ±20%
- 15W maximum load
- 1 kV isolation barrier internal to PXMP-MB
- Externally fuse circuit to protect wire
- Green power OK LED
- Three-position terminal block 16–12 AWG (1.31–3.31 mm<sup>2</sup>), wire ferrules recommended
  - T15—24 Vdc – (common)
  - T16—24 Vdc + (Hot)
  - T17—Shield (optional) capacitively referenced to chassis ground for enhanced EMC performance

#### Meter voltage inputs

- Overvoltage CAT III
- Maximum voltage rating
  - 480VL:G (corner grounded delta)
  - 347VL:N
  - 600VL:L
- Frequency rating 47–63 Hz
- Metering range (temporary transitions)
  - 30–700VL:N
  - 30–700VL:L
- Abuse withstand rating 1000V sustained
- High pot withstand rating 2500V/1min
- Input impedance 4M ohms
- Fuse inputs rated to protect wiring to mains. External fuses must be installed between the meter voltage terminal and the mains disconnect switch to the main lines to protect the lines. 600V 1 A BUSS type KTK-R-1 Fast Acting or equivalent fuses are recommended.
- Wiring to removable terminal plug 10–18 AWG (5.26–0.82 mm<sup>2</sup>), wire ferrules recommended
  - T18—N (VR)
  - T19—C (V3)
  - T20—B (V2)
  - T21—A (V1)

#### PXMP meter modules (PXMP-MMs)

Compatible with all PXMP Meter Base slots 1–10 LED indicators:

- Health and status green, blink to show activity
- Pulse energy output one red per group of three loads
- Load energy direction red/green pair per load

All variations support six load inputs.

Current sensor connection is one 2 x 2 connector per load.

Compatible with PXMP-SCXX sensor cables, total cable length to the sensor should not exceed 30 ft (1.94m).

Note that -AB suffix only affects what voltage channels the loads are paired with for metering purposes.

PXMP-MM10MA supports the CSXXX series of 10 mA maximum secondary output current transformers.

PXMP-MM100MA supports the PXMP-CSXXX series of 100 mA maximum secondary output current transformers.

PXMP-MM333MV supports 333 mV maximum secondary output current transformers with the use of the PXMP-IM333MV interface module.

#### PXMP digital output module (PXMP-DOM)

- Compatible with all PXMP-MB slots 1–10
- LED indicators
  - Health and status green, blink to show activity
  - Output On/Off status one green per output
  - Eight individual solid-state relay outputs
- Each circuit rated for 24 Vdc (±20%) with an 80 mA load maximum
- 24 Vdc is externally sourced
- Group isolation to ground 2 kV
- Each circuit has its own separate common, circuit-to-circuit isolation 120V
- 16-position removable terminal plug
- 12–18 AWG (3.31–0.82 mm<sup>2</sup>), wire ferrules recommended

#### PXMP pulse input modules (PXMP-PIMs)

- Compatible with all PXMP-MB slots 1–10
- LED indicators
  - Health and status green, blink to show activity
  - Input On/Off status one green per pulse input
- Eight pulse inputs to external dry contacts
- Maximum pulse rate is 20 Hz
- Minimum pulse width is 20 milliseconds
- External circuit groups rated for 24 Vdc (±20%)
  - All circuits share the same electrical common
- External supply connects to the module with a two-position removable terminal plug
- The supply is internally fanned out to all circuits
- Group isolation limited to 300V to ground due to TVS diode clamp
- Input impedance ~2.2K causing a 10 mA load per input when energized
- External circuit groups connect with a 16-position removable terminal plug
  - Terminals support 12–18 AWG (3.31–0.82 mm<sup>2</sup>), wire ferrules recommended

**PXMP energy portal module (PXMP-EPM)**

- Only functionally compatible with PXMP-MB slot 10
- LED indicators
  - Top health and status green, blink to show activity
  - Com. reset button—reset to defaults
  - Local IP 192/10
  - RJ45 front-facing Ethernet configuration port LEDs
    - Link (Tx/Rx blink)
    - 10/100 speed
- LED four-stack for bottom LAN/WAN Ethernet port
  - Link (Tx/Rx blink)
  - 10/100 speed
  - DHCP/Fixed
  - TX active
- Config. Ethernet RJ45 Cat5 STP/UTP
  - 10Base-T/100Base-Tx
  - Auto crossover capability supported
  - Java Web browser interface
- Bottom facing LAN/WAN Ethernet port
  - RJ45 Cat5 STP/UTP 10Base-T/100Base-Tx
  - STP required for full electromagnetic immunity
  - Auto crossover capability supported
  - Supports Modbus TCP and Java Web browser interface
- Bottom-facing telephone modem interface
  - Modem type V92/56K baud
  - RJ11 field interface

**Table 4. Power Xpert Multi-Point Meter System—Hardware Specifications**

| Components   | Field Circuit                                 | Power Source   | Rated Voltage | Rated Current  | Circuit Impedance | Isolation              | Note 1  | Note 2  |
|--------------|---|----------------|---------------|----------------|-------------------|------------------------|---|---|
| PXMP-MB      | Digital output                                | External       | 24 ±20% ①     | 0.080A maximum | 35 ohms maximum   | 2.0 kV                 | —   | —   |
| PXMP-MB-AB   | Digital input                                 | External       | 24 ±20% ①     | 0.01A          | 2.22K             | 2.0 kV                 | Opto drops supply by 2V   | Group are electrically common   |
|              | COM1 RS-485                                   | Internal       | 5V ①          | —              | 50–60 ohms        | 300V                   | TVS diode clamped to PE   | —   |
|              | COM2 RS-485                                   | Internal       | 5V ①          | —              | 50–60 ohms        | 300V                   | TVS diode clamped to PE   | —   |
|              | Power supply input                            | External       | 24 ±20% ①     | 0.7A maximum   | N/A               | 1.0 kV                 | Installation Class II input   | 15W maximum   |
|              | Voltage inputs A (V1)/ B (V2)/ C (V3)/ N (VR) | External mains | 480V L:G ②    | 0.12 mA        | 4M ohms           | N/A                    | Installation Class III  | High pot 2500V/1 minimum  |
| 347V L:N ②   |   |                | 0.09 mA       | 4M ohms        | N/A               | Installation Class III | High pot 2500V/1 minimum  |   |
| 600V L:L ②   |   |                | 0.09 mA       | 4M ohms        | N/A               | Installation Class III | High pot 2500V/1 minimum  |   |
| PXMP-MM100MA | CT secondary                                  | External       | N/A           | 100 mA         | 14.6 ohms         | N/A                    | 20% over-range  | See sensor for primary isolation  |
| PXMP-MM10MA  | CT secondary                                  | External       | N/A           | 10 mA          | 67 ohms           | N/A                    | 20% over-range  | See sensor for primary isolation  |
| PXMP-MM333MV | CT secondary                                  | External       | 0.333V ②      | N/A            | 50,000 ohms       | N/A                    | 20% over-range  | See sensor for primary isolation  |
| PXMP-DOM     | Digital output                                | External       | 24 ±20% ①     | 0.080A maximum | 10 ohms maximum   | 2 kV group             | 120V isolation circuit-to-circuit   | Isolation dependent on external source  |
| PXMP-PIM     | Pulse input                                   | External       | 24 ±20% ①     | 0.01A          | 2.22K ohms        | 300V to ground         | TVS diode clamped to PE; group isolated, all circuits common to 24V external source | Note: Opto creates 2.2V drop sourced by 2.2K ohms; isolation dependent on external source |
| PXMP-EPM     | Ethernet 100 Bt                               | Internal       | —             | N/A            | N/A               | 1 kV                   | —   | —   |
|              | POT modem                                     | Internal       | —             | N/A            | N/A               | —                      | —   | —   |

① DC.

② AC RMS.

## Catalog information

The Power Xpert Multi-Point Meter, current sensors, and other accessories can be ordered from Eaton distributors. Refer to the following catalog numbers when ordering.

**Table 5. Power Xpert Multi-Point Meter Products**

| Product Description  | Catalog Number         |
|--|------------------------|
| <b>Meter Bases and Meter Modules with ABCN Voltage Inputs</b>                |                        |
| PXMP meter base—three-phase with ABCN voltage inputs                         | <b>PXMP-MB</b>         |
| PXMP meter module with six 100 mA inputs for use with PXMP current sensors   | <b>PXMP-MM100MA</b>    |
| PXMP meter module with six 10 mA inputs for use with IQMESII current sensors | <b>PXMP-MM10MA</b>     |
| PXMP meter module with six 333 mV inputs for use with 333 mV current sensors | <b>PXMP-MM333MV</b>    |
| <b>Meter Bases and Meter Modules with ABN Voltage Inputs</b>                 |                        |
| PXMP meter base—single-phase, three-wire with ABN voltage inputs             | <b>PXMP-MB-AB</b>      |
| PXMP meter module with six 100 mA inputs for use with PXMP current sensors   | <b>PXMP-MM100MA-AB</b> |
| PXMP meter module with six 10 mA inputs for use with IQMESII current sensors | <b>PXMP-MM10MA-AB</b>  |
| PXMP meter module with six 333 mV inputs for use with 333 mV current sensors | <b>PXMP-MM333MV-AB</b> |
| <b>IO Modules</b>  |                        |
| PXMP meter pulse input module with eight inputs                              | <b>PXMP-PIM</b>        |
| PXMP meter digital output module with eight outputs                          | <b>PXMP-DOM</b>        |
| <b>Communication Module</b>  |                        |
| PXMP meter energy portal module  | <b>PXMP-EPM</b>        |
| <b>Current Sensor Kits</b>   |                        |
| KIT, PXMP CS125 sensor, quantity of 3  | <b>PXMP-CS125-3</b>    |
| KIT, PXMP CS250 sensor, quantity of 3  | <b>PXMP-CS250-3</b>    |
| KIT, PXMP CS400 sensor, quantity of 3  | <b>PXMP-CS400-3</b>    |
| <b>Current Sensor Cable Kits</b>   |                        |
| KIT, PXMP sensor cable, 4 ft (1.2m), quantity of 3                           | <b>PXMP-SC4-3</b>      |
| KIT, PXMP sensor cable, 6 ft (1.8m), quantity of 3                           | <b>PXMP-SC6-3</b>      |
| KIT, PXMP sensor cable, 8 ft (2.4m), quantity of 3                           | <b>PXMP-SC8-3</b>      |
| KIT, PXMP sensor cable, 12 ft (3.7m), quantity of 3                          | <b>PXMP-SC12-3</b>     |
| <b>Current Sensor Extension Cable Kits</b>                                   |                        |
| KIT, PXMP sensor extension cable, 8 ft (2.4m), quantity of 3                 | <b>PXMP-SCE-8-3</b>    |
| KIT, PXMP sensor extension cable, 16 ft (4.9m), quantity of 3                | <b>PXMP-SCE-16-3</b>   |
| <b>Interface Modules</b>   |                        |
| PXMP current sensor interface module for 333 mV, kit X 3                     | <b>PXMP-IM333MV-3</b>  |

**Note:** Total sensor lead length must not exceed 28 ft (8.5m).

The Pulse Input Module (PXMP-PIM) can be used to totalize pulse outputs from water meters, gas meters, steam meters, or even old electrical meters with KZ pulse outputs. The PXMP-PIM can also be used for status monitoring in applications where status indication updates of 6 seconds over Modbus satisfies the application requirement.

Support products for the Power Xpert Multi-Point Meter include the HMI display, IMPCABLE, and power supplies as described in **Table 6**.

**Table 6. Power Xpert Multi-Point Meter Support Products**

| Product Description                                      | Catalog Number     |
|--|--------------------|
| Communication cable, 1000 ft (305m), 600V insulation     | <b>IMPCABLE</b>    |
| PXMP meter display—6-inch color touchscreen (with cable) | <b>PXMP-DISP-6</b> |
| Power supply—single-phase 90–264 Vac, 24 Vdc at 2.5A     | <b>PSG60E</b>      |
| Power supply—three-phase 360–575 Vac, 24 Vdc at 2.5A     | <b>PSG60F</b>      |
| Power supply—three-phase 600 Vac, 24 Vdc                 | <b>PSS55D</b>      |

**Table 7. Meter Selection**

| Meter Module    | Meter Base  |                                   | Typical Applications  |   |   |                                 |
|-----------------|---|-----------------------------------|---|---|---|---------------------------------|
|                 | Three-Phase Application or Single-Phase with ABCN | Single-Phase Application with ABN | New Switchboards PXMP Current Sensors, Solid Core, PXMP-CSXXX, Ampere Ratings | Retrofit Existing IQMESII Sensors, Solid Core, CS-XXX, Ampere Ratings | Enclosed PXMP 333MV Sensors, Split Core, CS-SP-X-XXXX-333MV, Ampere Ratings | Enclosed PXMP Interface Modules |
| PXMP-MM100MA    | PXMP-MB   | —                                 | 125, 250, 400   | —   | —   | —                               |
| PXMP-MM333MV    | PXMP-MB   | —                                 | —   | —   | 100, 200, 300, 400, 600, 800, 1000, 1200, 1600, 2000 ①                      | PXMP-IM333MV                    |
| PXMP-MM10MA     | PXMP-MB   | —                                 | —   | 5, 50, 70, 125, 200, 400  | —   | —                               |
| PXMP-MM100MA-AB | —   | PXMP-MB-AB                        | 125, 250, 400   | —   | —   | —                               |
| PXMP-MM333MV-AB | —   | PXMP-MB-AB                        | —   | —   | 100, 200, 300, 400, 600, 800, 1000, 1200, 1600, 2000 ①                      | PXMP-IM333MV                    |
| PXMP-MM10MA-AB  | —   | PXMP-MB-AB                        | —   | 5, 50, 70, 125, 200, 400  | —   | —                               |

① For applications requiring more than 2000A current sensors, use a CS005 with 5A CT in conjunction with PXMP-MM10MA.

**Eaton**  
1000 Eaton Boulevard  
Cleveland, OH 44122  
United States  
Eaton.com

© 2013 Eaton  
All Rights Reserved  
Printed in USA  
Publication No. TD150006EN / Z14371  
October 2013



Eaton is a registered trademark.

All other trademarks are property of their respective owners.