

Power Xpert® Multi-Point Meter Quick Start Guide



Contents

Description	Page
Product Overview	2
Ordering Information	2
Material Selection – Example	4
Meter Base	5
Meter Base Assembly	5
Voltage Inputs	6
Meter Modules	7
Current Sensors	9
Sensor Orientation	9
Pulse Input Module	11
Digital Output Module	11
Energy Portal Module	12
Touch Screen Display	13
Communication Ports	14
PXMP Configuration Software	14

Product Overview

The Eaton Power Xpert® Multi-Point Meter (PXMP Meter) offers a highly modular approach to high density metering applications in electrical power distribution. The PXMP Meter is compatible with most 3-phase industrial, commercial, and single-phase residential low voltage electrical power systems. Typical applications include feeder and branch circuit load monitoring found in switch and panel boards, however higher level metering is possible with interposing load sensors and potential transformers. The modularity of the PXMP Meter allows this metering system to be customized to suit each metering installation based on the number and type of circuits to be metered. Up to ten different PXMP Meter Modules (PXMP-MMxxxx) can be mixed and matched within a PXMP Meter Base (PXMP-MB) to accommodate a total of up to 60 poles of metering channels from a variety of 1, 2, 3 pole loads.

Various meter modules can be mixed and matched in a single PXMP Meter Base with support for split core sensors, solid core sensors, or both based on the circuits that need to be metered. In addition, PXMP Pulse Input Modules (PXMP-PIM) can be installed into a PXMP Meter base for pulse metering from other electricity, gas, water, air, or steam meters.

Output modules are available for either remote control over Modbus or automatic control by the PXMP Meter based on customer configured threshold triggers. A PXMP Energy Portal Module (PXMP-EPM) is available that can make metered data available to individual tenants via an embedded WEB server. The Energy Portal module also supports a variety of protocols including Modbus TCP, SMTP, SNMP, FTP, HTTP, and more. In addition to Ethernet, the Energy Portal Module supports an optional dial up telephone connection for interface with remote billing software. A Touch Screen Display is available for local display of metered data from any circuit.

Ordering Information

The PXMP Meter system offers the flexibility to be used in a variety of applications and can be customized, using the modular components, to fit most installations. **Table 1** lists the modular components available for the PXMP Meter system.

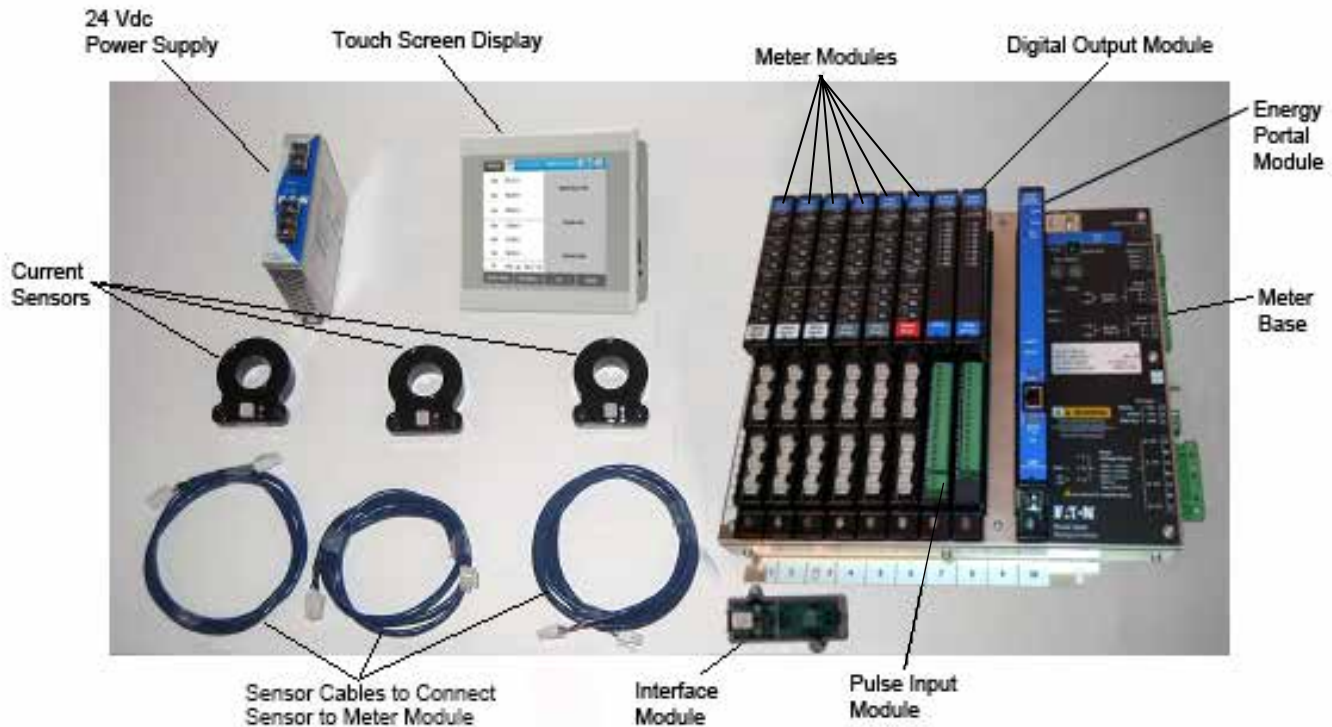

Figure 1. Components of the PXMP Meter System.

Table 1. PXMP Meter System – Modular Components.

Catalog Number	Description
PXMP-MB Meter Bases	
PXMP-MB*	PXMP Meter Base - 3PH/1PH 2W w/ ABCN Voltage Inputs
PXMP-MB-AB**	PXMP Meter Base - 1PH 3W w/ ABN Voltage Inputs
PXMP-MMXXXX Meter Modules	
PXMP-MM10MA	PXMP Meter Module w/ 6 10 mA Inputs
PXMP-MM100MA	PXMP Meter Module w/ 6 100 mA Inputs
PXMP-MM333MV	PXMP Meter Module w/ 6 333 mV Inputs
PXMP-MM10MA-AB	PXMP Meter Module w/ 6 10 mA Inputs - 1 PH 3W
PXMP-MM100MA-AB	PXMP Meter Module w/ 6 100 mA Inputs - 1 PH 3W
PXMP-MM333MV-AB	PXMP Meter Module w/ 6 333 mV Inputs - 1 PH 3W
PXMP-PIM	PXMP Meter Pulse Input Module w/ 8 Inputs
PXMP-DOM	PXMP Meter Digital Output Module w/ 8 Outputs
PXMP-EPM Energy Portal Modules	
PXMP-EPM	PXMP Meter Energy Portal Module
PXMP-EPM-M	PXMP Meter Energy Portal Module w/ Modem
PXMP-CSXXX Current Sensors with 100 mA Max. Outputs	
PXMP-CS125-3	PXMP CS125 Sensor (100 mA output) - Kit x 3
PXMP-CS250-3	PXMP CS250 Sensor (100 mA output) - Kit x 3
PXMP-CS400-3	PXMP CS400 Sensor (100 mA output) - Kit x 3

* = PXMP-MB only supports PXMP-MM10MA-AB, PXMP-MM100MA-AB, and PXMP-MM333MV-AB.
** = PXMP-MB-AB only supports PXMP-xxxxxxx-AB modules.

Catalog Number	Description
CSXXX - Current Sensors with 10 mA Max. Outputs	
CS070	Current Sensor Module 70 Amps (10 mA output) - Kit x 6
CS125	Current Sensor Module 125 Amps (10 mA output) - Kit x 3
CS200	Current Sensor Module 200 Amps (10 mA output) - Kit x 3
CS400	Current Sensor Module 400 Amps (10 mA output) - Kit x 3
CS005	Current Sensor Module 5 Amps (10 mA output) (For use with 5 Amp CTs) - Kit x 3
Sensor Cables for PXMP-CSXXX and PXMP-IMXXX	
PXMP-SC4-3	PXMP Sensor Cable, 4 Ft. (1.22 m) - (male/male) Kit x 3
PXMP-SC6-3	PXMP Sensor Cable, 6 Ft. (1.8 m) - (male/male) Kit x 3
PXMP-SC8-3	PXMP Sensor Cable, 8 Ft. (2.44 m) - (male/male) Kit x 3
PXMP-SC12-3	PXMP Sensor Cable, 12 Ft. (3.66 m) - (male/male) Kit x 3
PXMP-SC28-3	PXMP Sensor Cable, 28 Ft. (8.5 m) - (male/male) Kit x 3
Sensor Cable Extensions	
PXMP-SCE8-3	PXMP Sensor Extension Cable, 8 Ft. (2.44 m) - (male/female) Kit x 3
PXMP-SCE16-3	PXMP Sensor Extension Cable, 16 Ft. (4.88 m) - (male/female) Kit x 3
(Current Sensor) Interface Modules	
PXMP-IM333MV-3	PXMP Current Sensor Interface Module (for 333 mV) -Kit x 3
PXMP-IM100MV-3	PXMP Current Sensor Interface Module (for 100 ma) -Kit x 3
PXMP-DISP Display	
PXMP-DISP-6-XV	6-inch Color Touch-Screen Interface, Preloaded and Optimized for Use with the PXMP-MB (-AB)
PXMP-DISP-6-TM	6-inch Color Touch-Screen Interface, Preloaded and Optimized for Use with the PXMP-MB (-AB), limited menu items - designed for tenant use.
PXMP-DISP6XV-DAT	Replacement cable - PXMP-DISP-6-XV
PX-PMBH-XV	PXM-DISP-6 to PXM-DISP-6-XV adapter plate
24 Vdc Power Supplies	
PSG60E	85-264 Vac 1-PH / 120-375Vdc Input, 24Vdc @2.5A (60W) Output
PSG120E	85-264 Vac 1-PH / 120-375Vdc Input, 24Vdc @5A (120W) Output
PSG240E	85-264 Vac 1-PH / 120-375Vdc Input, 24Vdc @10A (240W) Output
PSG480E	85-264 Vac 1-PH / 120-375Vdc Input, 24Vdc @20A (480W) Output
PSG60F	320-575 Vac 3-PH / 450-800Vdc Input, 24Vdc @2.5A (60W) Output
PSG120F	320-575 Vac 3-PH / 450-800Vdc Input, 24Vdc @5A (120W) Output
PSG240F	320-575 Vac 3-PH / 450-800Vdc Input, 24Vdc @10A (240W) Output
PSG480F	320-575 Vac 3-PH / 450-800Vdc Input, 24Vdc @20A (480W) Output

For more information on PSG Series DC Power Supplies go to; www.eaton.com > Products & Solutions > Electrical > Products & Services > Automation & Control > Power Supplies and Temperature Controllers > PSG series DC Power Supplies

Material Selection – Example

The application below (details described in upper left section of the drawing) is to monitor various 3-phase and single-phase breakers in an Eaton IFS Switchboard (see Figure 2). The required PXMP hardware layout is shown and the required modules per slot are listed on this drawing. Individual selection steps are listed at the bottom of the page.

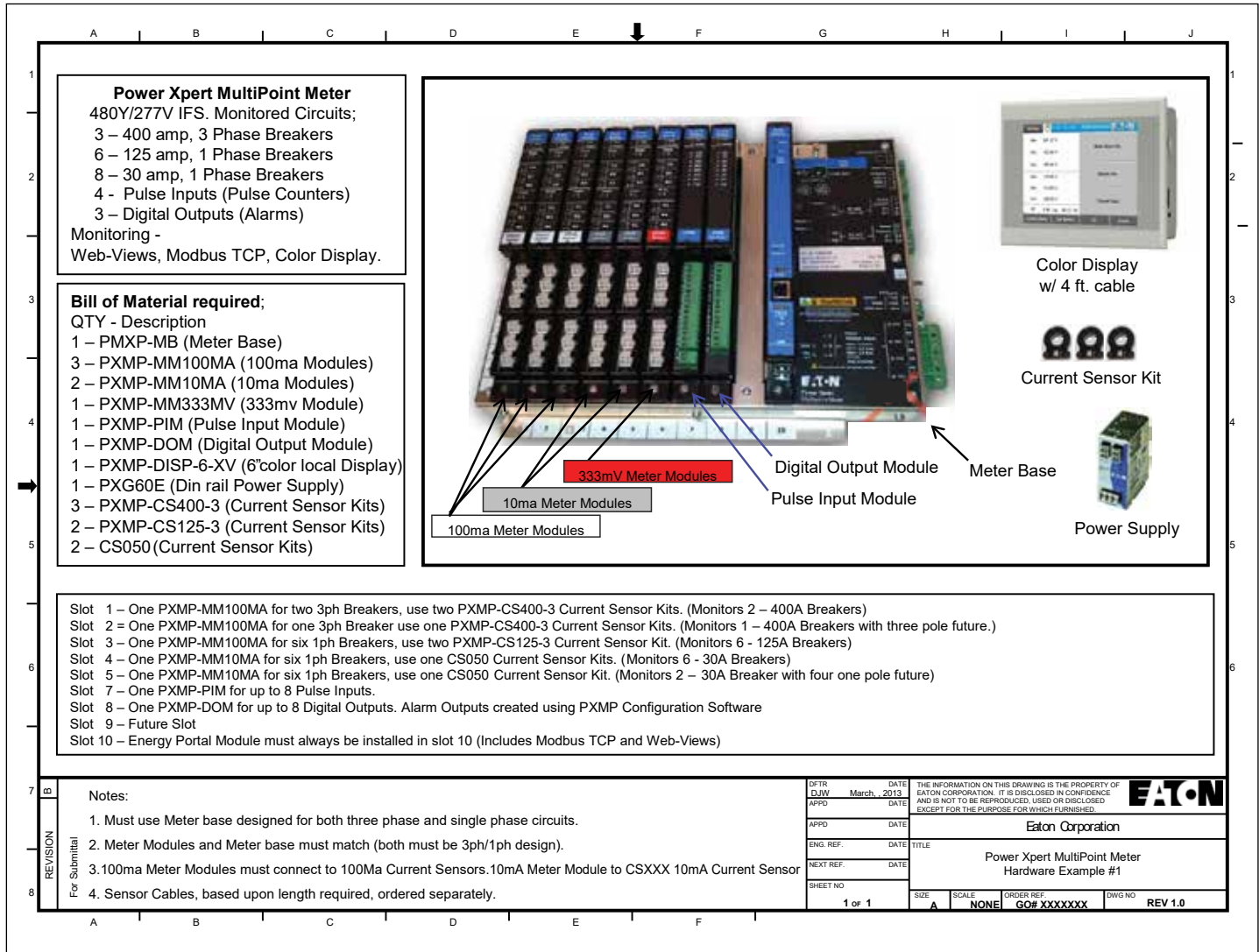

Figure 2. Example PXMP Meter Configuration.

- Step 1. Select the PXMP-MB; 3-phase and single-phase monitoring required - Use PXMP-MB Base.
 - Step 2. Select the PXMP Meter Modules (PXMP-MMxxxx). Match 3-phase/single-phase modules to (3-phase/single-phase) PXMP-MP meter base.
- Note:** Modules can be either 100 mA, 10 mA and or 333 mV rated.
- Step 3. Select the number of PXMP-MMxxxx; two 3-phase per module or six single-phase per module.
 - Step 4. Select the current sensor type; (match current sensors to PXMP-MMxxxx).

Note: Use 100 mA CS w/ 100 mA module, 10 mA CS w/ 10 mA module, 333 mV CS w/ 333 mV module.

- Step 5. Select the Modbus TCP - use PXMP-EPM (Ethernet Comms and Web-Views).
 - Step 6. Select the sensor cable extensions - add PXMP-SCx-3 cables between PXMP-MMxxxx and current sensors as needed.
- Note:** CSxxx sensors include 48" (1.22 m) cables. 333 mV sensors require an interface module.
- Step 8. Select the local display - use PXMP-DISP-6-XV (provided with a 72" (1.8 m) cable, connects to PXMP-MB port).
 - Step 9. Select the power supply - use PXG60E (Din rail mount 120 to 24 Vdc).

Meter Base

Both PXMP Meter Base assembly models are shipped without modules. The front of the base has a label indicating 10 positions or slots (1-10), where modules can be mounted. Each position is covered with a metal slot cover secured to the assembly with screws. The slot covers protect the backplane of the PXMP-MB assembly. Slot covers are removed to insert modules, but should be left in place if the slot is not being used. The ten slots provided are multi-purpose. They can accommodate any combination of PXMP-MMxxxx (10 mA, 100 mA, or 333 mV), PXMP-PIM, or PXMP-DOM.

Note: The PXMP-MB (3-phase 4-Wire Wye, 3-phase 3-Wire Delta (grounded), and single-phase Metering) can be used on 3-phase, 2-phase, and single-phase applications. The PXMP-MB-AB (120/240 V, single-phase 3-Wire service) can ONLY be used on single-phase applications. The PXMP-MB-AB base has a yellow label on the lower left of base (see Figures 3 and 4).



Figure 3. PXMP-MB (White Label).



Figure 4. PXMP-MB-AB (Yellow Label - Shown with Three Modules Installed).

Meter Base Assembly

The PXMP-MB assembly includes a solid-state relay output that can be configured as a Pulse Initiator output assigned to any one of the tenant meters or to the aggregate sum of the tenant meters. An external 24 Vdc power supply is required to drive the load limited to 80 mA maximum. The PXMP-MB assembly also includes three digital status inputs that can be used to indicate conditions such as a demand synch pulse or a rate alert. These digital inputs require external 24 Vdc voltage +/- 20% to operate.

The Mode DIP switches are located behind the metal door cover at the top left corner of the black label face of the PXMP-MB assembly panel. These Mode switches are used to secure the PXMP Meter in one of three levels of hardware enforced security modes. Note the tab on the base that can be used to seal the door shut for security purposes.



Figure 5. PXMP-MB Assembly Components and LEDs.

The PXMP-MB assembly includes the following LED indicators:

- Three LEDs marked A, B, and C, adjacent to the Meter Voltage Input connector, indicate if voltage is applied to the meter phase inputs and is within the expected range.
- Two LED's are marked Delta or Wye/1PH and used to indicate the active metering mode configuration.
- Red and green TX and RX LED's adjacent to Com 1 and Com 2 provide visual indication of Transmit and Receive activity on the communication ports.
- A Health LED indicates that the PXMP-MB main microprocessor is functioning correctly.
- A Power LED indicates that 24 Vdc is applied to the 24 Vdc input to the PXMP-MB.
- A Status LED indicates that communication activity between the PXMP-MB and PXMP-MMxxxx.

Voltage Inputs

Metering voltage inputs connect to the right side of the PXMP-MB and PXMP-MB-AB assemblies. Inputs are marked A (V1), B (V2), C (V3), and N (VR) on both the PXMP-MB and PXMP-MB-AB assemblies. If connecting to a Delta system, the unused N (VR) terminal should be connected to chassis ground. A cover for the voltage terminal is provided as a barrier to hazardous terminal access.

Note: On the PXMP-MB-AB, even though the voltage input label on the assembly lists the "C" connection, it will never be used in PXMP-MB-AB applications.

When commissioning a PXMP Meter, ensure that the phasing is consistent between the voltage input terminal and the load current sensor input connections on the PXMP-MMxxxx. If a current sensor is plugged into a connection point on the PXMP-MM that is assigned to a different phase voltage, metering errors will result due to the current and voltage phasing mismatch (see Sections 4.3.4 - Current Sensor Installation and 6 - Configuring and Commissioning of IM150001EN for detailed information).

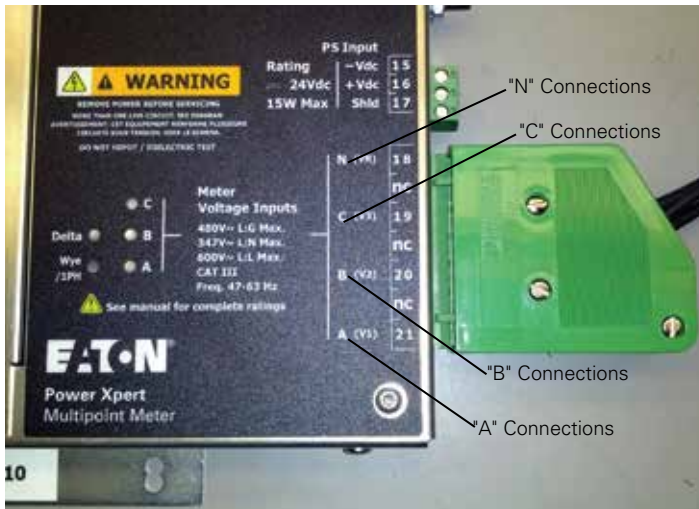

Figure 6. A, B, C, and N Connections on the PXMP-MB Assembly Meter Voltage Input.

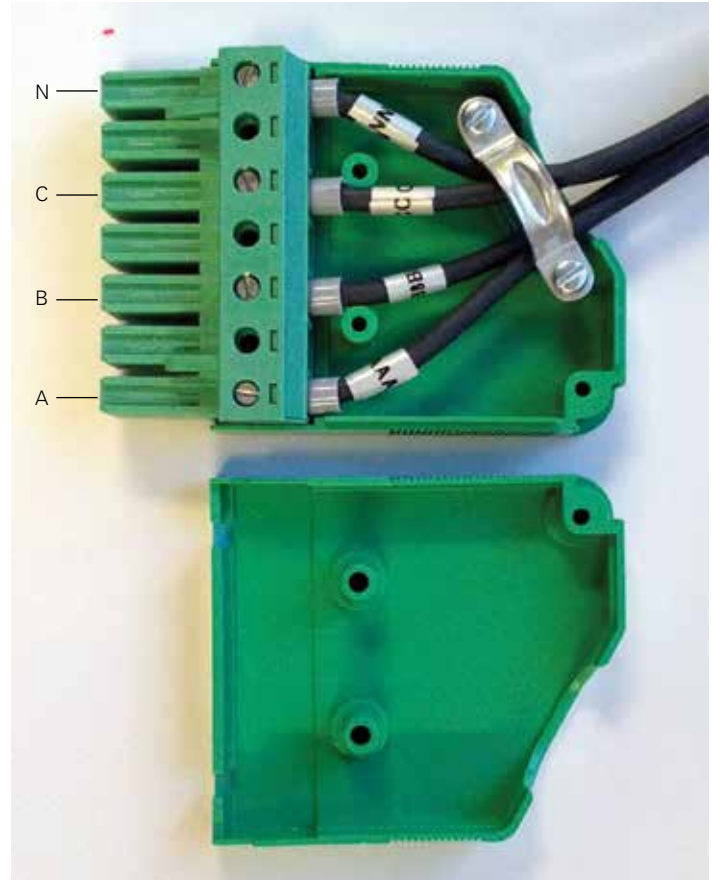

Figure 7. Meter Voltage Input Terminal Plug and Cover.

Meter Modules

Each PXMP-MM has six 2 x 2 female receptacles for current sensor connections. Each 2 x 2 receptacle can be considered to be in one of six rows of connection points for the PXMP-MMxxxx that are normally installed in slots one through nine. Each horizontal row is paired with the phase voltage indicated on the phase assignment label to the left. For the PXMP-MB assembly, the bottom row of three connectors is always Phase A, the second row from the bottom is always Phase B, and the third row from the bottom is always Phase C. The same applies to the upper set of three connectors. Note the PXMP-MB CT inputs label is WHITE and the PXMP-MB-AB CT Inputs label is YELLOW to help distinguish between these two PXMP-MB designs. For the PXMP-MB-AB assembly, the bottom row is always Phase A1, then working upwards Phase B1, Phase A2, Phase B2, Phase A3, and Phase B3 at the top.

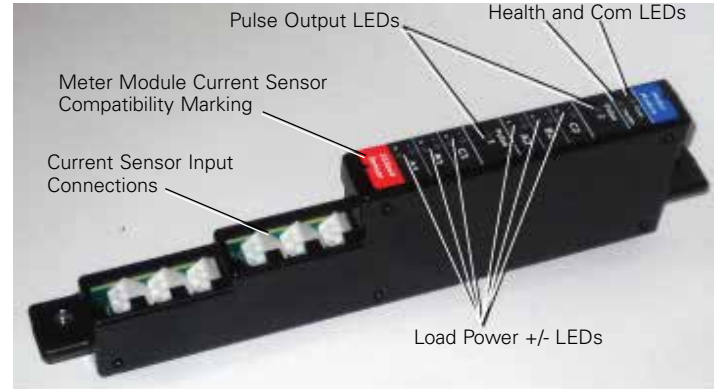

Figure 9. Typical PXMP-MM.

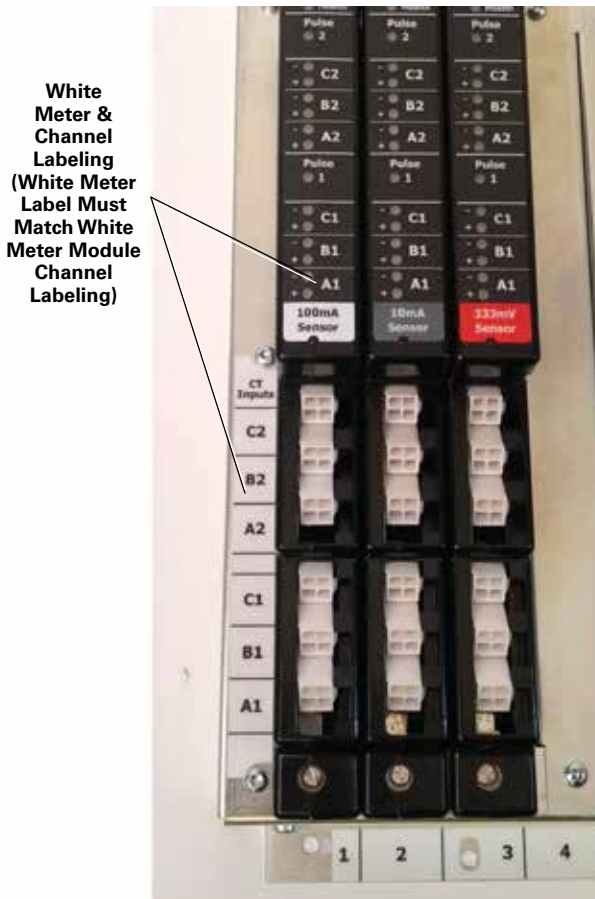

Figure 8. PXMP-MB Examples.

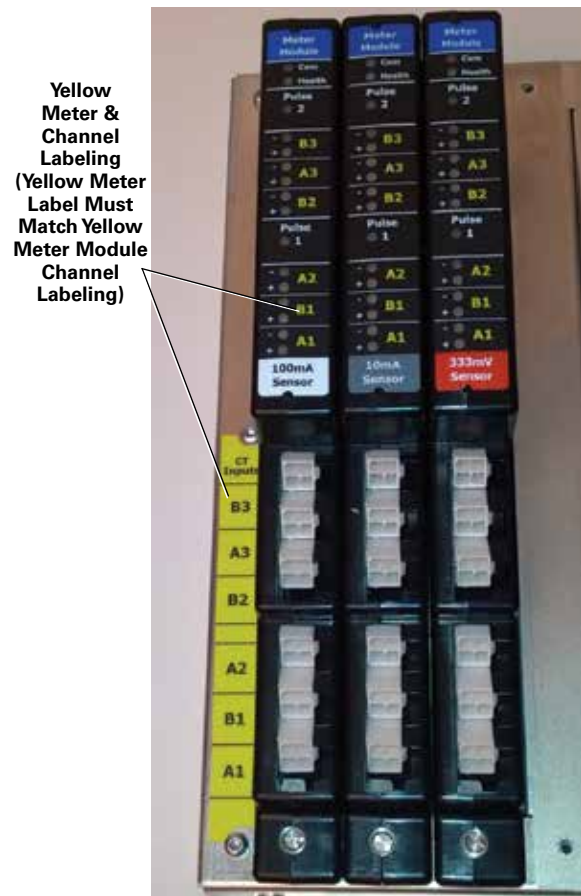

Figure 10. .PXMP-MB-AB Examples.

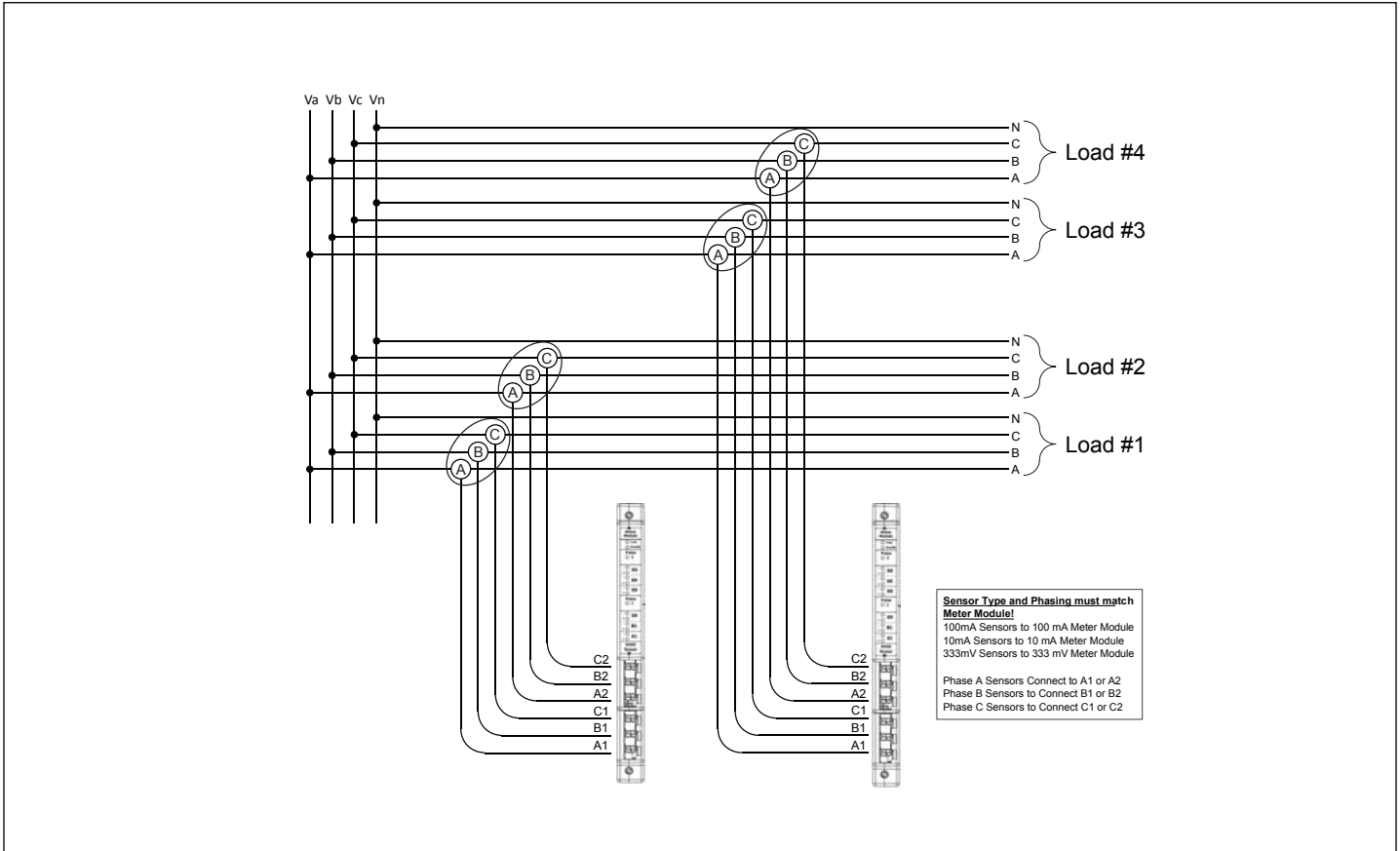

Figure 11. Typical Wiring – 3-Phase 4-Wire Wye.

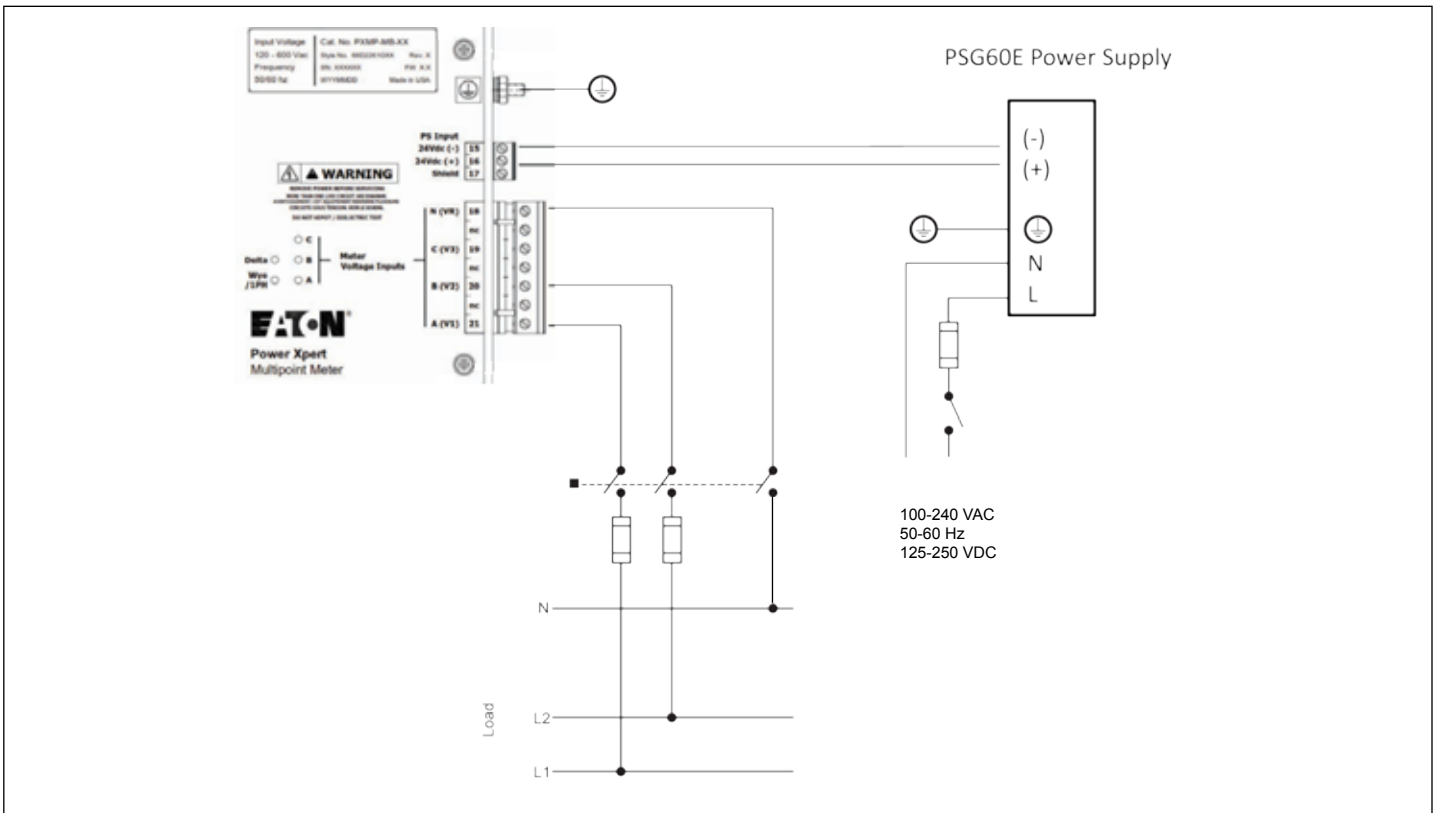

Figure 12. Typical Wiring – Single-Phase 3-Wire 120/240.

Current Sensors

Three different types of current sensors can be used with the PXMP Meter based on secondary output type and range. The PXMP Meter is compatible with direct connection to 100 mA, 10 mA, and 333 mV maximum rated secondary current sensors. All single CT applications require that the CT provides Double/Reinforced Insulation 600V, CATIII. By using interposing current transformers such as the CS005, current transformers with 1 or 5 Amp outputs can be interfaced. Each current sensor is slightly different. Some require special mounting.

The PXMP-MMxxxx are directly compatible with Eaton's CSXXX 10 mA and PXMP-CSXXX 100 mA current sensors. The CSXXX current sensors have an integral yellow 4 ft (1.22 m) cable while the PXMP-CSXXX current sensors require a separate PXMP-SC sensor cable that is in available 4/6/8/12 ft. (1.22/1.83/2.44/3.66 m) lengths to help cleanly match the application dimensions. Generic 333 mV output current sensors must use the PXMP-IM333MV Interface Modules and a PXMP-SC Sensor Cable to interface with a PXMP-MM. In a PXMP Meter System, the CSXXX 10 mA secondary output sensors should be connected only to a PXMP-MM10MA 10 mA Meter Module. The 10 mA sensor cables are yellow in color, ~ 48 in. (1.22 m) long and are built integral with the sensor. Eight and 12 ft. (2.44 and 3.66 m) extensions are available to extend the distance between the sensor and the Meter. Do not exceed 28 ft (8.53 m) total length.



Figure 13. PXMP-CSXXX Current Sensor - 100 mA.



Figure 14. PXMP Current Sensor Cable.



Figure 15. 10 mA CS125 Solid Core Current Sensor with Integral

48 in. (1.22 m) Cable.

Sensor Orientation

The orientation of the sensor relative to the load current flow is important for proper metering. Current sensing is directional. Sensors should be mounted on the insulated load cables facing the load current back to front as shown by the arrow on top of the sensor or similar direction marking. An incorrect orientation results in an incorrect energy reading.

Two LED indicators per load circuit on the PXMP-MM will indicate the power polarity. Note that the green LED on the PXMP-MM indicates current flow towards the load. The red LED indicates current is flowing from the load towards the source. Normally, a red LED indicates that the sensor is mounted backwards. The red LED would be correct if the circuit being monitored is a generator not a load. If there is not adequate current flow, the sensor cable is disconnected or the PXMP-MB assembly is powered down, or if the meter voltage inputs are disconnected then these indicators will be off.

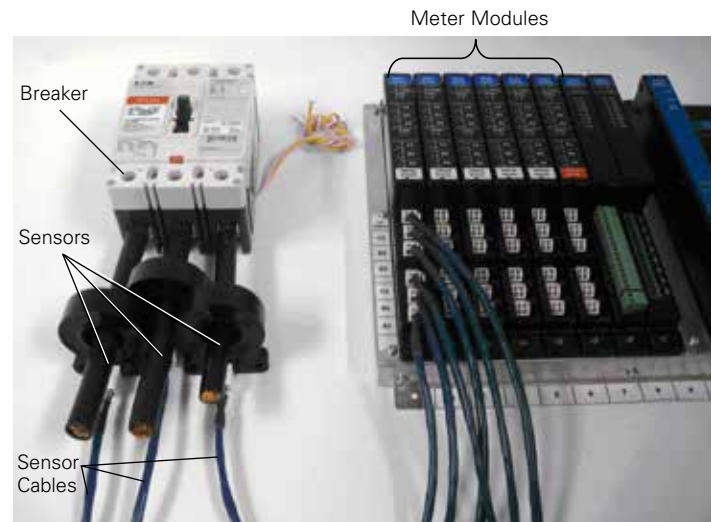

Figure 16. Typical Wiring Arrangement of Sensor Connected to Meter Module.

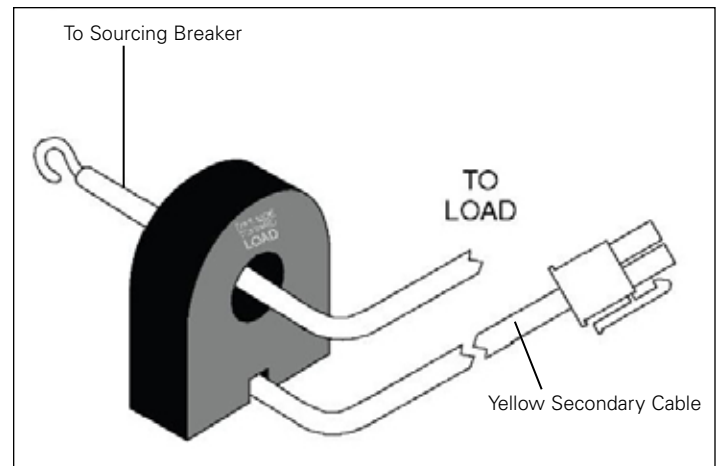

Figure 17. CS050/125/200/400 Current Sensors – Load Orientation.

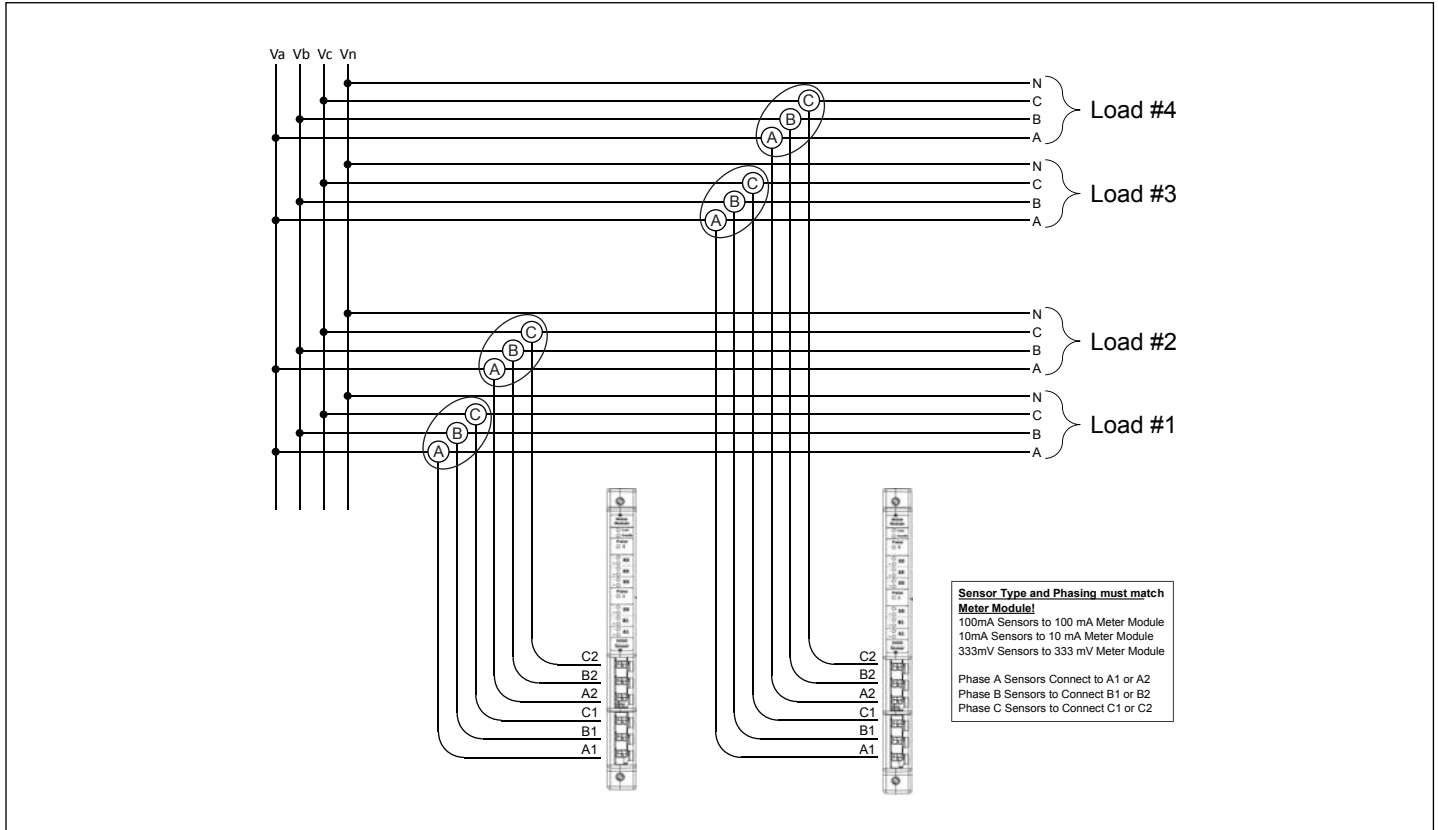

Figure 18. 3-Phase 4-Wire Service Using Two 3-Phase Current Sensors.

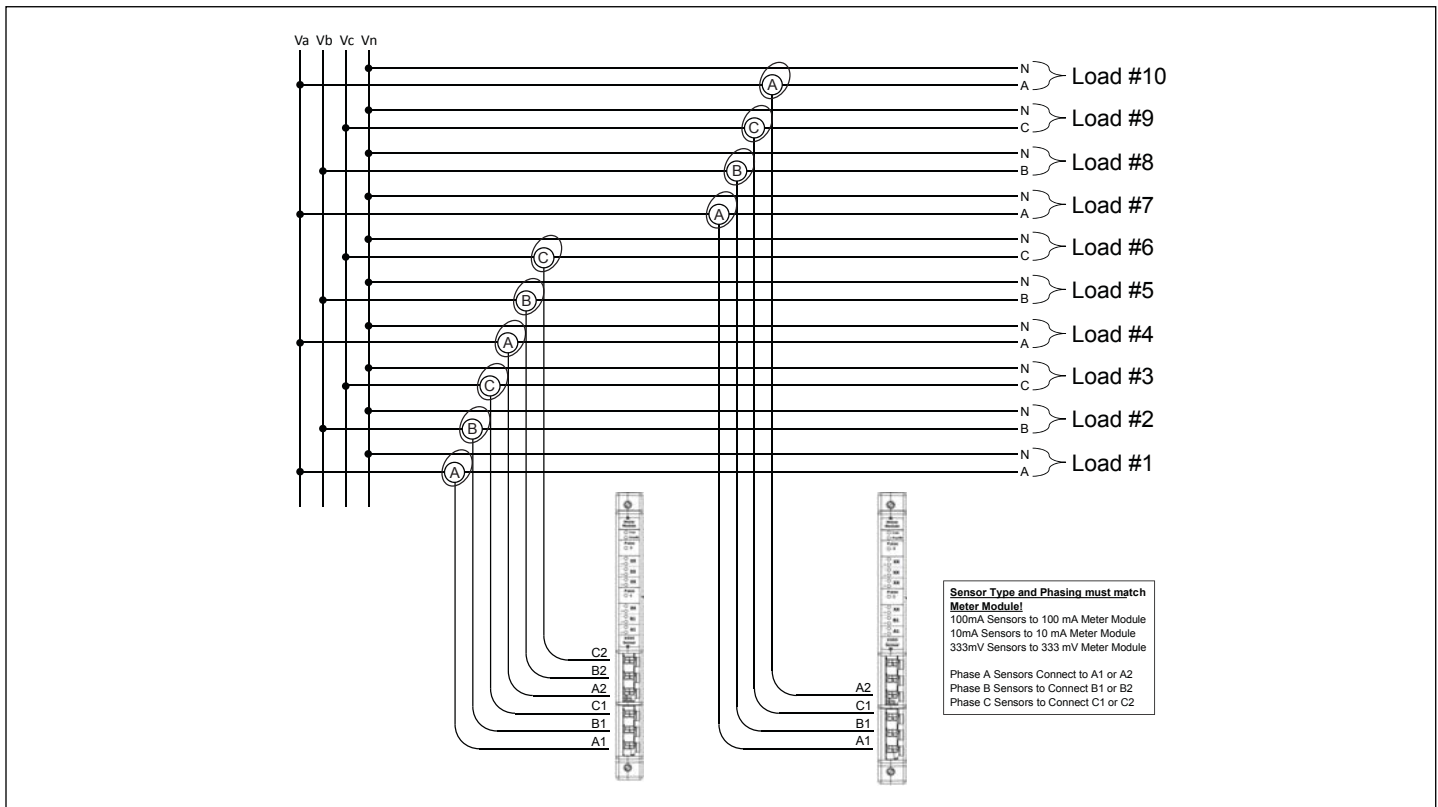

Figure 19. 3-Phase 4-Wire Service Using Ten Single-Phase, 1 Pole Current Sensors.

Pulse Input Module

The PXMP-PIM has terminals for eight digital inputs. Eight front facing LEDs on the Pulse Input Module flash when digital inputs transition.

- LED On = Contact closed, current flowing into input;
- LED Off = Contact open; no current flowing;

The PXMP-PIM has a 2-position, 24 V power supply terminal that must be connected to an external 24 Vdc power supply. The same 24 V power supply that is used for the PXMP-MB assembly can be used for the PXMP-PIM.

Input of the source pulse must be a dry contact. Each PXMP-PIM has a 2.2 K ohm input impedance drawing approximately 10 mA per closed input. All the commons are tied together internally.

Metering of ten, 3-phase tenants, for example, would require five PXMP-MMxxxx to meter ten, 3-phase loads (two tenants per meter module).



Figure 20. PXMP-PIM.

Digital Output Module

The PXMP-DOM provides outputs from the PXMP-MB logic to external circuit groups. These outputs are used for control or to indicate alarm conditions. A typical installation might be for building automation systems.

The PXMP-DOM can be controlled remotely over Modbus, or driven by logic from the PXMP-MB, based on customer configuration.

The PXMP-DOM requires an external power source of 24 Vdc +/- 20% V. Each solid state relay can support a maximum load of 80 mA. Each Solid state relay circuit is electrically

The PXMP-DOM plugs into the PXMP-MB with captive screws. These screws, when tightened, ground the module to the PXMP-MB and to the earth ground. The PXMP-DOM has eight front-facing LEDs to display the status of each output. Other LEDs indicate COM Status and Health.

External 24 Vdc source should be dedicated for local PXMP use only, do not connect to a CAT III source.



Figure 22. PXMP-DOM.

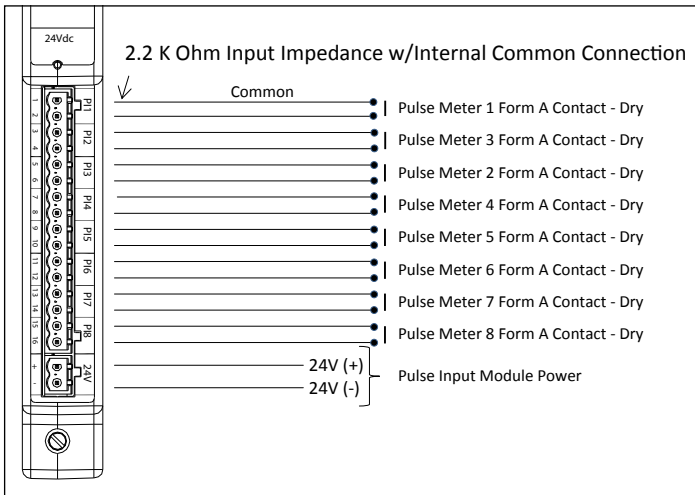

Figure 21. PXMP-PIM Wiring.

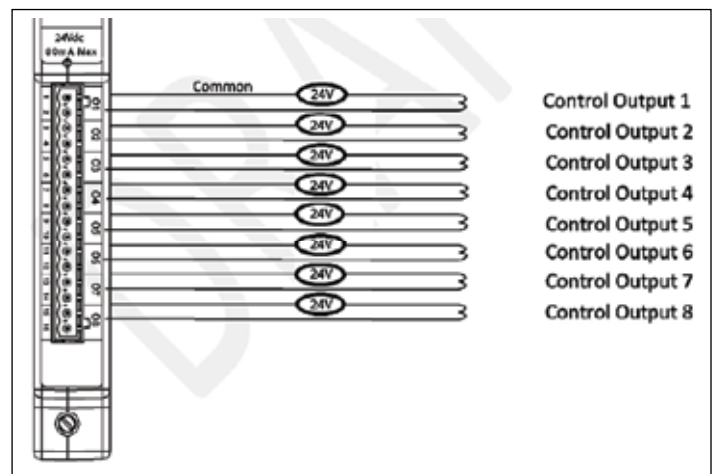

Figure 23. PXMP-DOM Wiring.

Energy Portal Module

The PXMP-EPM adds sophisticated Web enabled metering capability to the PXMP Meter. A typical application would be for storing the results of metering utilities (electric, gas, water, or steam), for serving an apartment complex, tenant by tenant.

Stored data for each tenant is then available over Ethernet with the support of an embedded HTML5 interface that is pre-loaded in the PXMP-EPM. This module can be ordered as PXMP-EPM-M which supports internal dial up telephone modem with RJ11 connection at the bottom of the module for interface with remote billing software in applications where network connections are not possible or practical.

Once the PXMP-EPM is configured with an IP address, the user interface can be accessed over a Local Area Network (LAN). Metering data can be viewed for each tenant, as well as an aggregated sum of the tenant meters. This feature allows for E-Allocation, or the limiting of energy consumption tenant by tenant.

The PXMP-EPM comes standard with a front facing Ethernet RJ-45 configuration port and a LAN/WAN RJ-45 Ethernet jack on the bottom end.

The Energy Portal Module plugs into the tenth slot of the PXMP-MB assembly. It will not function properly in any other slot. The PXMP-EPM is secured with captive screws that, when tightened, ground the PXMP-EPM to the Meter Base and to the earth ground. For configuration and application details please refer to the "PXMP Energy Portal Web Interface and User Manual" (MN150003EN).

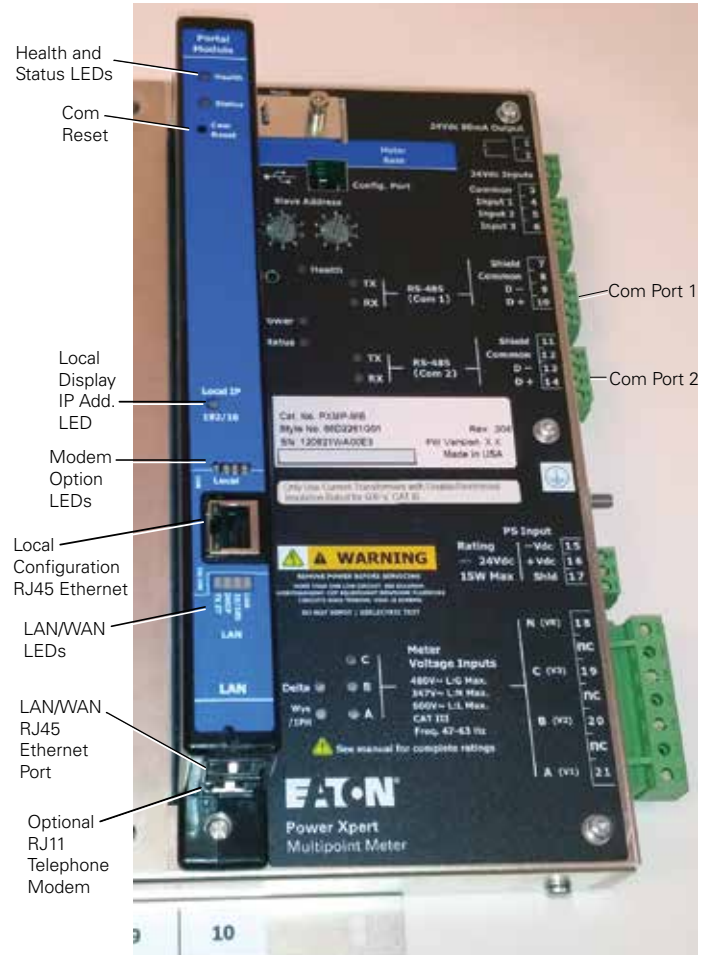

Figure 24. PXMP-EPM.

Touch Screen Display

The Eaton PXMP-DISP-6-XV, is an Eaton XV-102-H4-57TVRL-10 pre-loaded with software for use exclusively with the PXMP-MB(-AB). A 6 ft (1.8 m) communication cable is used to connect the PXMP-DISP-6-XV DB9 port to the PXMP-MB(-AB) RS-485 COM 2 port, enabling the PXMP-DISP-6-XV to be mounted up to 6 ft (1.8 m) away from the PXMP-MB(-AB).

The display provides the User with the ability to locally view meter readings to help troubleshoot problems that may arise, and view power system metering data when a computer is not handy or available.

The optional display is for system monitoring purposes only and cannot be used to set-up the PXMP Meter. Set-up of the meter must be done using the PXMP Configuration Software (see MN150002EN).

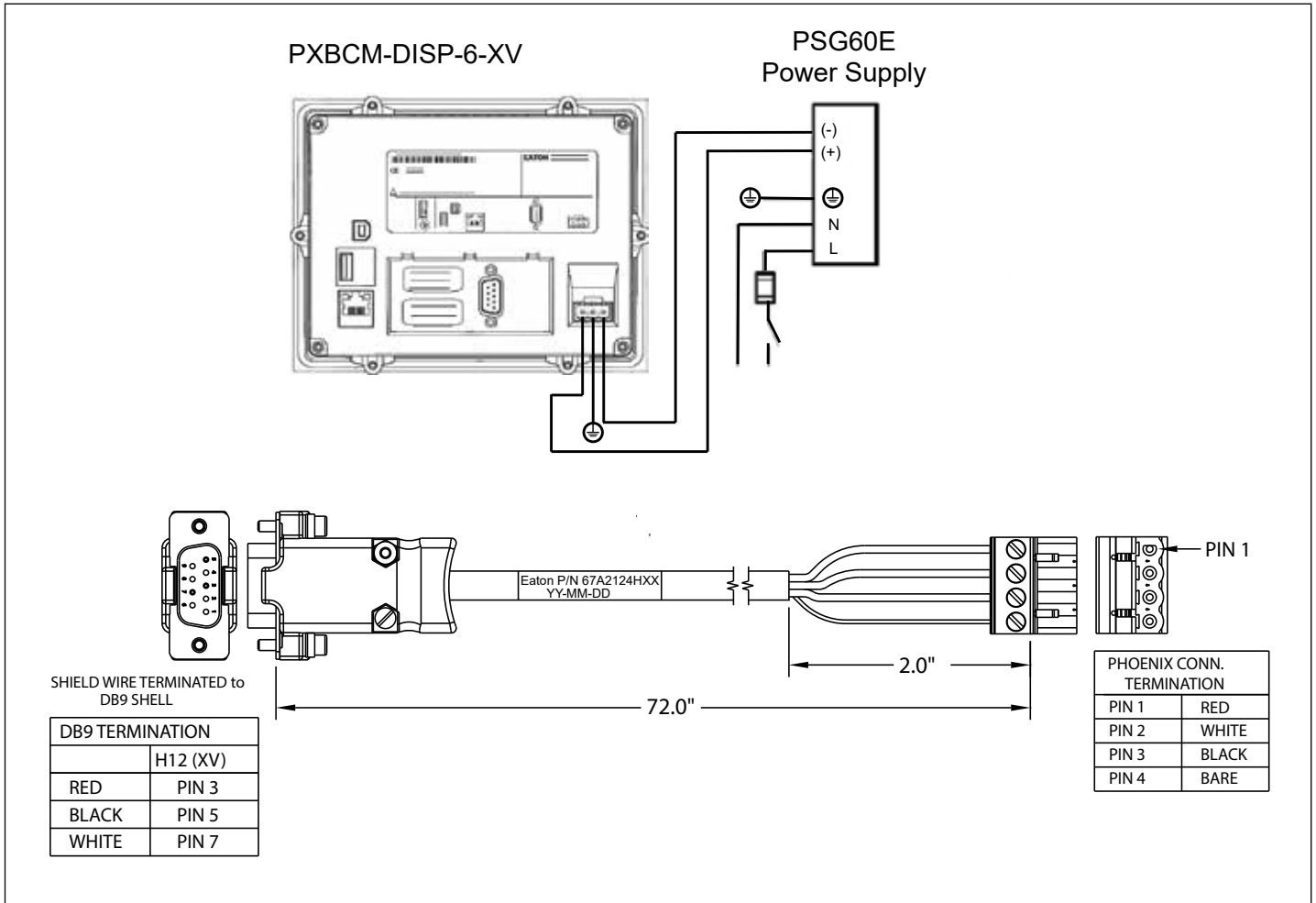

Figure 25. PXMP Touch Screen Display and Wiring Information.

Communication Ports

The PXMP Meter provides two Com ports with RS485 serial interfaces supporting Slave Modbus RTU protocol. Com 1 and Com 2 provide two RS-485 serial communication ports supporting Modbus Slave RTU protocol.

Two rotary switches are used to select Modbus Slave Addresses 01 to 99. The Modbus Slave Address selected applies to both RS-485 COM Ports.

The default configuration settings for the RS-485 COM ports: 115.2k Baud Rate, 8 bit Word length, No Parity, and 1 Stop Bit. The RS-485 COM port configuration settings can be changed using the PXMP Configuration Software.

The PXMP Configuration Software can be used to adjust these communication settings.

The slave port connectors include a Data+ (D+), Data- (D-), Common, and Shield terminals. Eaton recommends the use of RS-485 wiring that includes a twisted pair for data, a conductor for common, and a separate shield for optimal signal integrity and noise immunity. There are some variations on RS-485 wiring. If the PXMP-MB assembly is to be inserted into a daisy-chain that does not have an independent common and shield, the common and shield terminals can be jumpered externally on the terminal block so that the RS485 common will connect via the shield between nodes.

PXMP Configuration Software

The PXMP Configuration Software is a JAVA application provided free of charge by Eaton to support the configuration and commissioning of the PXMP Meter. This utility is included on a CD provided with each PXMP-MB. The software can also be downloaded from Eaton's website www.eaton.com/pxmp. Please refer to the PXMP Configuration Software Manual MN150002EN for details.

For local configuration of a PXMP Meter, the software can be run on a laptop computer equipped with JAVA 1.7 or higher. For instructions on the use of the PXMP Configuration Software Manual MN150002EN.

To simplify PXMP configuration, a Wizard is provided that guides the operator through a complete configuration process. The software supports both online and offline configuration sessions. To conduct an online session, connect the laptop to the USB port on the PXMP-MB using a standard USB cable with a Type B USB connector to interface with the meter. Start the software and it will automatically connect to the PXMP Meter. Configuration can also be done over an RS-485 Modbus communications link to either of the PXMP Meter's Com ports 1 or 2.

When launched, the PXMP Configuration Software presents the User with a screen that allows the base information for the electrical system to be entered.

After the base electrical system information has been entered, the PXMP Configuration Software allows the User to enter the information for each slot in the PXMP-MB assembly.

In addition to device configuration, to verify correct device configuration and commissioning, the software can also be used in Monitor Mode to view the metering data for each tenant meter.

The PXMP Configuration Software is not intended for use as a permanently installed software solution and does not provide cost allocation functionality. Note also that the USB port is intended for temporary configuration setup, commissioning, and debugging purposes only.



Figure 26. PXMP Communication Ports.



Figure 27. Configuration Software Screen.



Figure 28. PXMP Configuration Software Meter Configuration Screen.

Additional Information

Detailed information on applications and options can be found in the Power Xpert Multi-Point Meter User Guide (IM150001EN). The guide can also be found at <http://www.eaton.com/pxmp>.

This Information Booklet is published solely for information purposes and should not be considered all-inclusive. If further information is required, you should consult an authorized Eaton sales representative.

The sale of the product shown in this literature is subject to the terms and conditions outlined in appropriate Eaton selling policies or other contractual agreement between the parties. This literature is not intended to and does not enlarge or add to any such contract. The sole source governing the rights and remedies of any purchaser of this equipment is the contract between the purchaser and Eaton.

NO WARRANTIES, EXPRESSED OR IMPLIED, INCLUDING WARRANTIES OF FITNESS FOR A PARTICULAR PURPOSE OR MERCHANTABILITY, OR WARRANTIES ARISING FROM COURSE OF DEALING OR USAGE OF TRADE, ARE MADE REGARDING THE INFORMATION, RECOMMENDATIONS, AND DESCRIPTIONS CONTAINED HEREIN. In no event will Eaton be responsible to the purchaser or user in contract, in tort (including negligence), strict liability or otherwise for any special, indirect, incidental or consequential damage or loss whatsoever, including but not limited to damage or loss of use of equipment, plant or power system, cost of capital, loss of power, additional expenses in the use of existing power facilities, or claims against the purchaser or user by its customers resulting from the use of the information, recommendations and description contained herein.

Eaton
Electrical Sector
1000 Eaton Boulevard
Cleveland, OH 44122
United States
877-ETN-CARE (877-386-2273)
Eaton.com

© 2019 Eaton
All Rights Reserved
Printed in USA
Publication No. IB150001EN / TBG001089
July 2019