

Power Xpert Meter 2000 Series

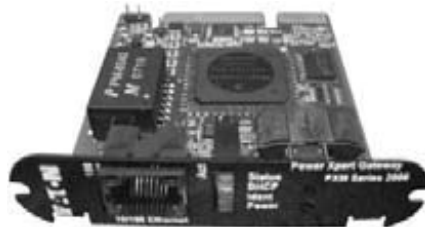

General Description

The Power Xpert® Meter 2000 Series power quality instrument monitors the most critical aspects of an electrical distribution system. This premier power quality metering instrument uses the latest in advanced technology to make it simple to use, powerful, scalable and highly flexible. The Power Xpert Meter 2000 offers the same level of intuitive user interface design as the Power Xpert Meter 4000/6000/8000, presenting critical electrical distribution system information in a simple to navigate and easy-to-understand information architecture.

The embedded Web server displays comprehensive power quality data using standard Internet browsers and allows for device configuration from the browser. The embedded Web server presents real time, historical, and event information in a browser style graphical format to help the user interpret information such as current loading, voltage and power levels, power factor, energy usage, I/O status, power quality measurements, as well as harmonic plots. The embedded Web server also allows for waveform capture and view to visualize steady-state harmonic content which is critical for power quality analysis.

The Web server provides the energy and demand readings required to help manage the cost of energy.

Applications

Identify power quality problems to help:

- Protect motors from damage.
- Preserve the integrity of processes and batches.
- Prevent blown capacitor bank fuses.
- Protect transformers and conductors from overheating.

Monitor circuit loading to help:

- Avoid overloads and nuisance overload trips.
- Maximize equipment utilization.
- Manage emergency overloads.

Manage energy utilization to help:

- Reduce peak demand charges and power factor penalties.
- Identify excessive energy consumption.

EATON

Powering Business Worldwide

Metered/Monitored Parameters

Note: See **Table 3**.

- Volts: L-L, L-N, Avg. L-L, Avg. L-N.
- Phase and neutral currents.
- Power: real, reactive and apparent.
- Frequency.
- Power factor: apparent.
- Energy: real, forward, reverse, sum.
- Demand: peak with date and time.
- % THD.
- Minimum and maximum values.
- Harmonics.
- Individual Harmonics.
- Demand comparisons.
- Phasors.

Accuracy

Note: Under typical operating conditions.

- Currents: 0.1% reading.
- Voltage: 0.1% reading.
- Energy, and demand power: 0.2% in accordance with ANSI C12.20.
- Frequency: +/- 0.03 Hertz.
- Power factor: 0.2% reading.

Communications

Multiple communications ports including:

Standard

- RS-485 Modbus RTU Slave port.
- 10/100Base-T Ethernet network port.

Communication Protocols Supported

- Modbus RTU
- Modbus TCP
- BACnet/IP
- Ethernet TCP/IP
- HTTP, HTTPS
- NTP (Network Time Protocol)
- SMTP (Simple Mail Transfer Protocol)
- SNMP (Simple Network Management Protocol) v1, v3
- DNP 3.0

Physical Characteristics

Format

- Power Xpert Meter 2000 with integral display.
- Power Xpert Meter 2000 transducer only (no display) meter module.
- NEMA rating: NEMA 12, IP42 front of panel rating.

Meter with Integral Display Dimensions

- Height: 4.85 inches (123.2 mm).
- Width: 4.85 inches (123.2 mm).
- Depth:
 - 3.96 inches (100.5 mm) behind panel surface
 - 1.01 (25.6 mm) projection in front of panel surface

Listings/Certifications

- UL/cUL Electrical and Electronic Measuring and Test Equipment 22CZ.
- Accuracy: IEC/EN60687 0.2 class, ANSI C12.20 0.2 Class.
- ANSI C62.41 Burst.
- CE Mark.

Power Xpert Meter 2000 Embedded Web Server

The Power Xpert Meter 2000 embedded Web server offers Eaton® customers a new level of accessibility to the critical information required to manage their electrical distribution system. The Web server includes real-time information in both numeric and graphical visual formats to help monitor parameters such as current loading, voltage and power levels, power factor, THD, and more. The Web server also provides energy and demand readings with graphic usage plots to help analyze energy usage patterns. Energy readings include kWh, kvarh, delivered and received and kVAh with time.

The Power Xpert Meter 2000 embedded Web server supports graphical trend charts of key measurements such as current, voltage, power and energy. The trend chart supports a zoom feature that allows the user to view data over predefined ranges from as little as 16 hours to as much as 4 years. The trend chart includes zoom in/out buttons and a horizontal slider bar control to manage scrolling forward and backward through the data. Trend charts of basic readings include minimum, maximum and average readings. Trend charts of interval by interval energy data also display peak demand.

Waveform Recording

The Power Xpert Meter 2000 can record waveforms at up to 512 samples per cycle.

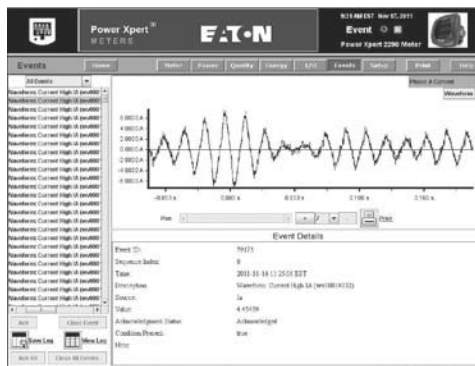

Waveform captures are automatically stored on the FTP server in the IEEE standard COMTRADE file format. This allows users to view and analyze the waveforms in any standard free-of-charge or commercial COMTRADE file viewer.

Historical Trend Logging

The Power Xpert Meter 2000 records historical data for graphical viewing from the embedded Web server. Graphical views of historical data support pan and zoom. Over 100 standard metering parameters are logged as part of the standard meter functionality including min./max. and average for each parameter. The averages are calculated over the interval period.

Energy Profile Data

The Power Xpert Meter 2000 records Real and Reactive energy forward, reverse, net and absolute sum, as well as Apparent energy (kVAH). These readings are stored on a fixed 5 minute interval. Up to 4 status inputs can be configured as energy accumulators for counting KYZ pulse inputs.

Demand Comparisons

Demand usage patterns can be analyzed with the month-to-month, week-to-week comparison chart built into the meter. Raw data can be exported as a .csv file with the "Save Table" option to other applications for further analysis and graphing.

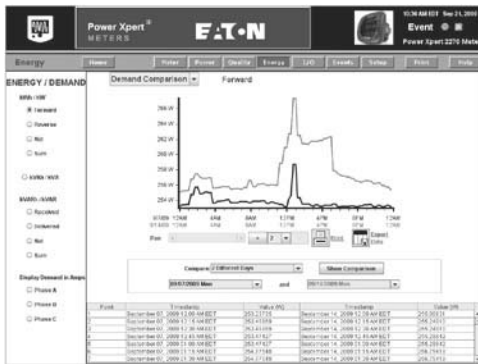

Event Triggers

The Power Xpert Meter 2000 has two levels of configurable event triggers:

- On-board meter limits (PXM 2260/2270/2280/2290).
- On-board gateway card limits.

The on-board meter limits can be set for any measured parameter, for up to 16 limits. If either of the 16 limits are exceeded, an alarm condition will be present and illuminate one of the LEDs on the meter faceplate. The on-board meter out of limits can also be used to energize a relay output, if so equipped.

The on board gateway limits can trigger an alarm off of any measured parameter on any of the PXM 2000 model series. These triggers permit pickup, reset and pickup delay to be configured by the user.

Event Logging

The Power Xpert Meter 2000 embedded Web server allows the user to view a list of triggered events. In addition, a separate system log records system operations such as resets.

Email

The Power Xpert Meter 2000 contains the ability to send emails based on an event that has been triggered or cleared along with the option to send an event or data log file. The Power Xpert Meter 2000 also has the ability to send a configurable periodic email with energy and event information.

Inputs and Outputs

Power Xpert Meter 2000 is available with a standard KYZ output and optional digital I/O cards which includes:

- 2 Relay Outputs/2 Status Inputs.
- 4 KYZ Pulses/4 Status Inputs.
- 4 Analog Outputs 0 – 1 mA.
- 4 Analog Outputs 4 – 20 mA.

Inputs can also be configured for demand synch and pulse counting. Inputs selected for pulse counting can be scaled. Accumulated pulse recordings are maintained in profile memory. Outputs can be used for alarm annunciation.

Ratings

- Application to any PT ratio, no PTs required to 600 Vac.
- CT ratios to any CT ratio.
- CT inputs available as 5 or 1 amp secondary.
- Separate Source Control Power Input:
 - 90 – 265 Vac or 100 – 370 Vdc
 - Low voltage 18 – 60 Vdc

Displayed Information

- Monitored information is available locally through the display, the Web browser or system power management software.
- True rms values through 40th harmonic.
- ANSI C12.20 Class .2% revenue metering specification.

Power Xpert Meter 2000 Web Browser Views

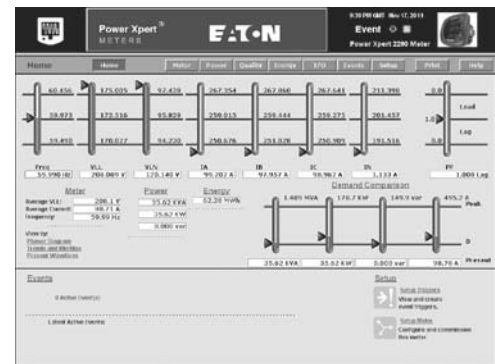

Power Xpert Meter 2000 Web Browser

Power Xpert Meter 2000's embedded Web server offers Eaton customers a new level of accessibility to the critical information required to manage the electrical distribution system. The embedded Web server includes real time circuit information in both numeric and graphical formats to help monitor parameters such as current loading, voltage and power levels and power factor. The Web server also provides the energy and demand readings required to help manage the cost of energy. Readings include kWh, kvarh, delivered and received and kVAh. The Web server also includes critical information regarding Power Quality such as harmonic distortion.

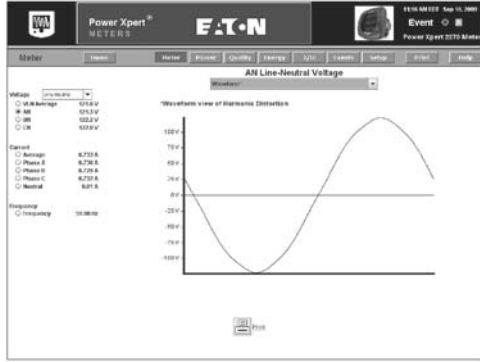

Real-Time Visualization of Harmonic Content

The Web server offers a waveform view to visualize steady-state harmonic content of the voltage and current to spot power quality problems.

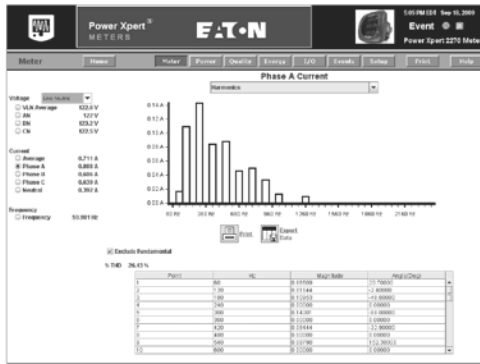

Harmonic Spectral Plot

The harmonic spectral plot displays harmonics up to the 40th order. A detailed table also includes individual magnitudes and angles of current and voltage harmonics, at each frequency. Individual and total THD are displayed for diagnostic purposes.

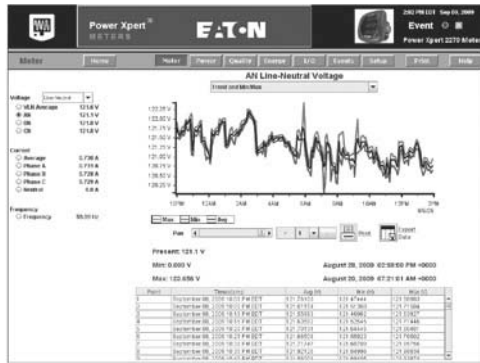

Historical Trend Plot

Graphical Trending of Data

The Power Xpert Meter 2000 embedded Web server supports graphical trend charts of key circuit measurements such as current, voltage, power and energy. The trend chart supports a zoom feature that allows the user to view data over a short period of 16 hours or a longer period of 48 months. The trend chart has a horizontal slider bar control to manage scrolling forward and backward through the data. Trend charts of basic readings include minimum, maximum and average readings. Trend charts of energy data also display demand values.

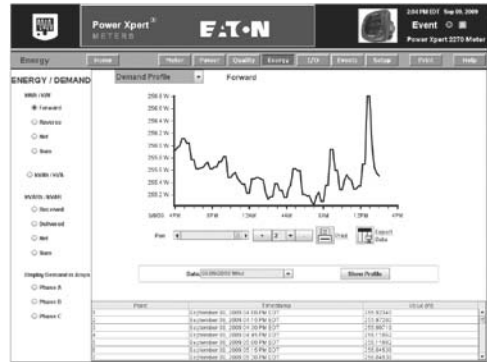

Energy Demand Profile

Energy Managers can view load profile data compared against the peak demand.

Web Server Device Configuration

Special software is not required to configure a Power Xpert Meter 2000. The embedded Web server includes a comprehensive device configuration engine.

Discrete Contact Inputs

The optional I/O expansion cards offers 2 or 4 digital inputs that are useful for a variety of applications such as:

- Pulse Counting of KYZ or other utility pulses such as air, water or gas.
- Demand interval timing taken from a master utility meter end of interval pulse.

Names can be configured for each input for ease of use.

Relay Outputs

The optional I/O card includes two 5 A form C relay outputs rated for 240 Vac or 30 Vdc or 4 Form A solid-state outputs. These outputs can be used for applications such as:

- Alarm annunciation.
- KYZ pulse output.

Alarm outputs can be driven from triggers based on metering values.

Analog Outputs

The optional IO card includes either four 4 – 20 mA outputs or 0 – 1 mA outputs. These outputs can be used for applications such as:

- Input to BMS or PLC systems for tracking a measured meter parameter.

Standard Communications Card

The standard communications card provides one Ethernet connection and 10/100Base-T port (copper only) that can be used for the following applications:

- Monitoring, managing and configuring the meter remotely using a standard Web Browser interface.
- Alarm notifications via email, SMTP.
- Providing Modbus TCP/IP, RTU, and BACnet/IP communications to BMS systems.
- Providing SNMP communications to NMS systems.
- Synchronizing with an NTP server.
- Asset management.
- Updating firmware on the meter.

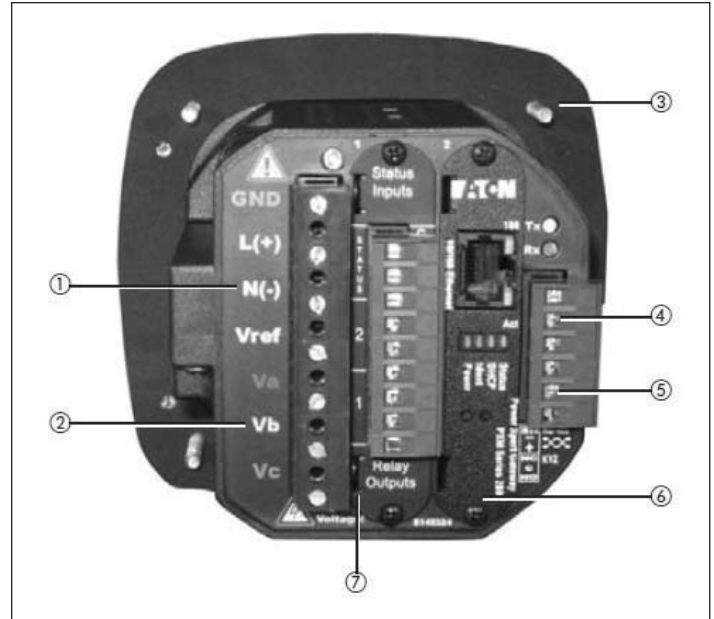

Figure 1. PXM 2000 Rear View

- ① Power Supply Inputs
- ② System Voltage Inputs
- ③ NEMA 12 Gasket
- ④ RS-485
- ⑤ KYZ Out
- ⑥ Meter Gateway Card
- ⑦ I/O Slot

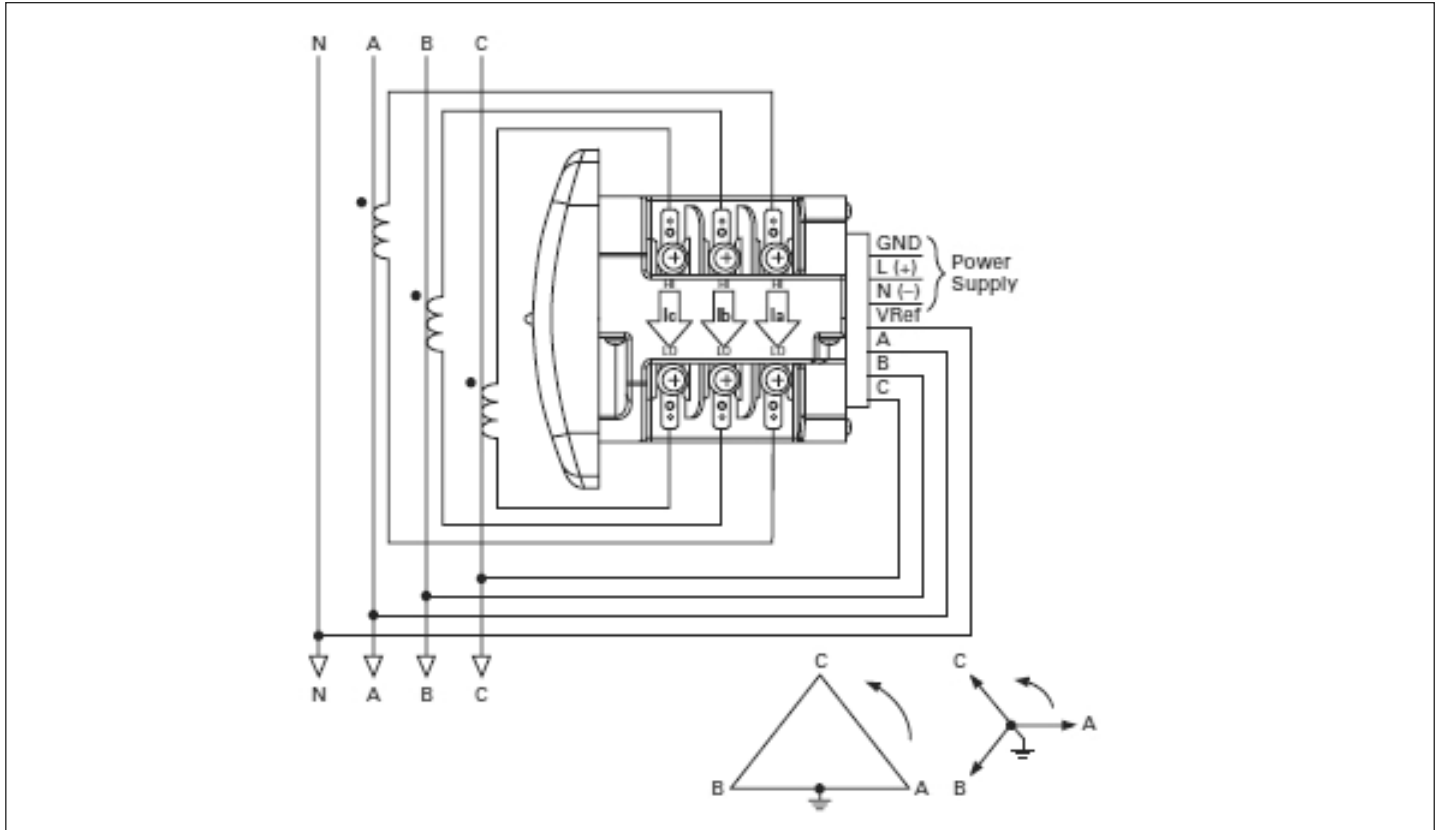

Figure 2. Service: WYE or Delta, 4-Wire with No PTs, 3 CTs

Note: Based upon the voltage rating, you may need a control power transformer for the control power.

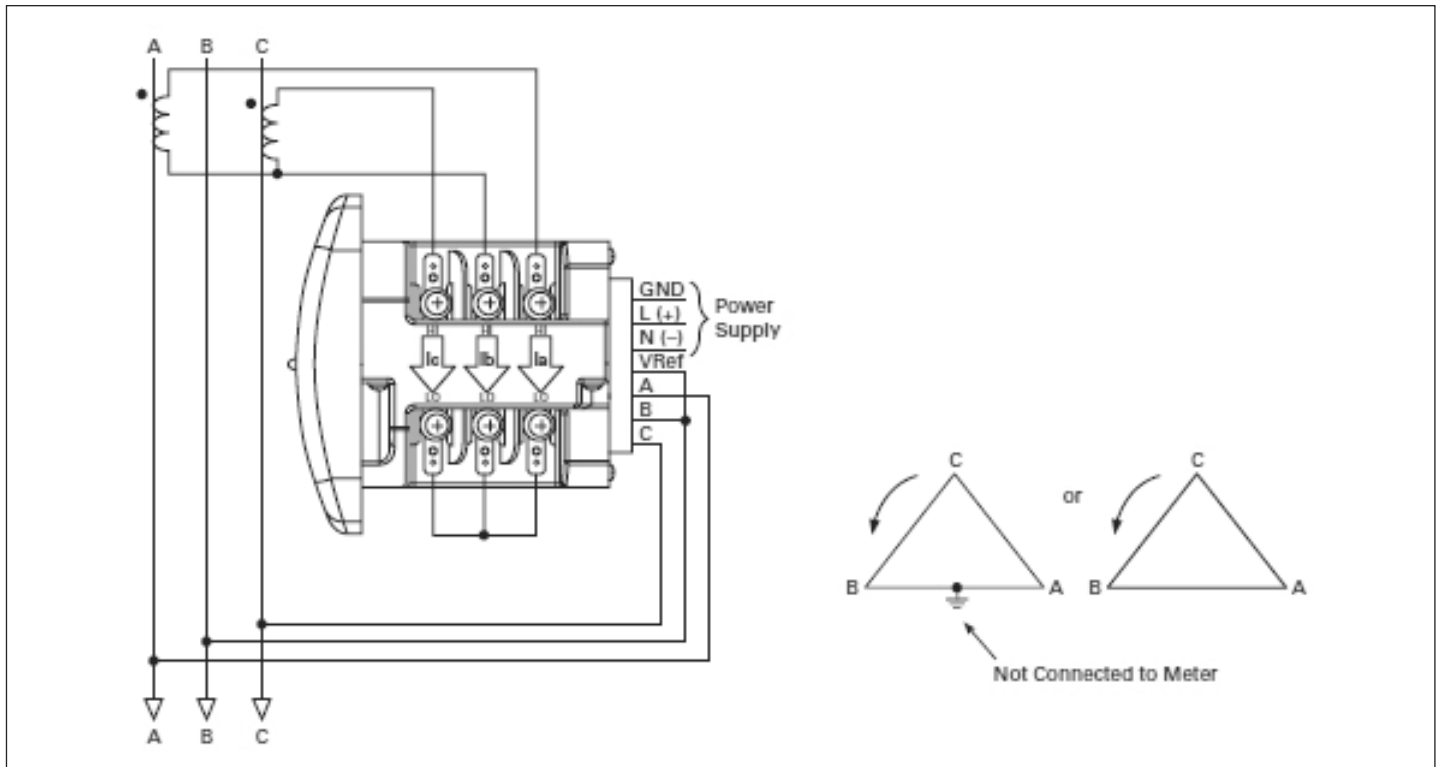

Figure 3. Service: Delta, 3-Wire with No PTs, 2 CTs

Note: Based upon the voltage rating, you may need a control power transformer for the control power.

Power Xpert Meters Configuration and Wiring Examples

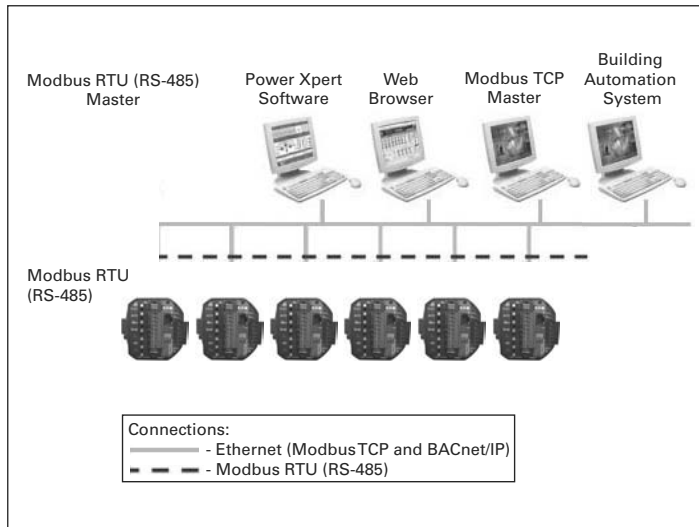

Figure 4. Web Enabled – Advanced System Functionality



Figure 5. IT Configuration Examples – Accessories – I/O Cards (Option)

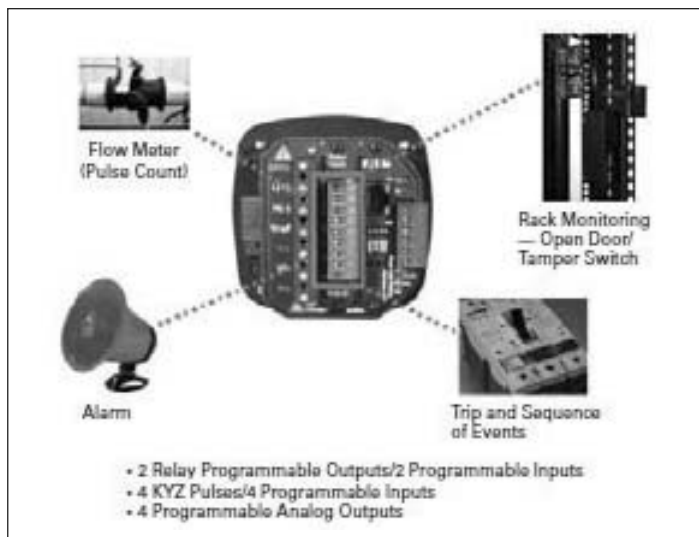

Figure 6. Accessories – I/O Cards (Option)

PXM 2000 Dimensions

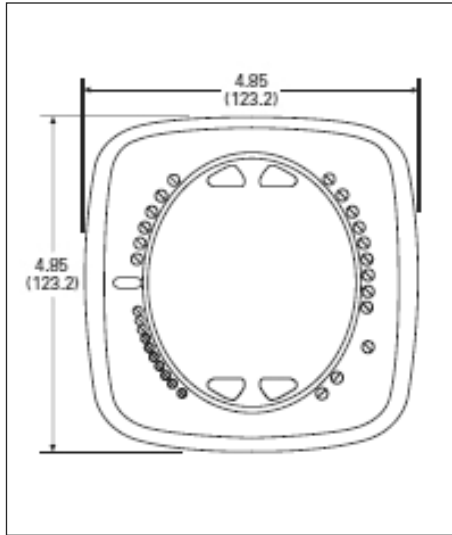

Figure 7. PXM 2000 Display Front View

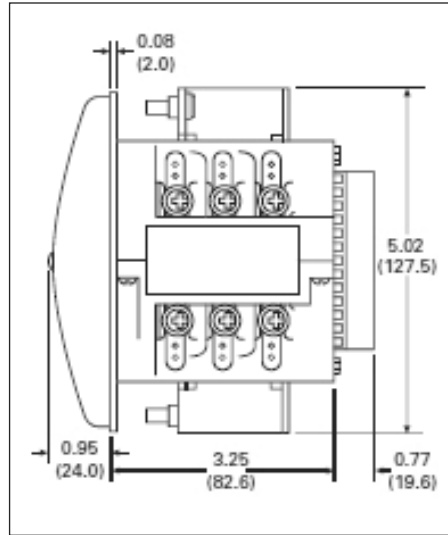

Figure 8. PXM 2000 Meter/Display Side View

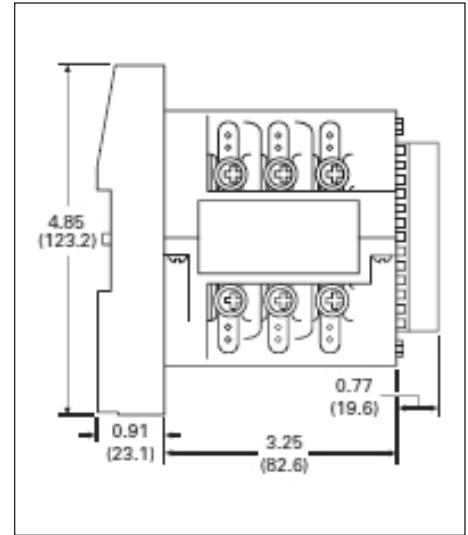

Figure 9. PXM 2000 Transducer Only Side View

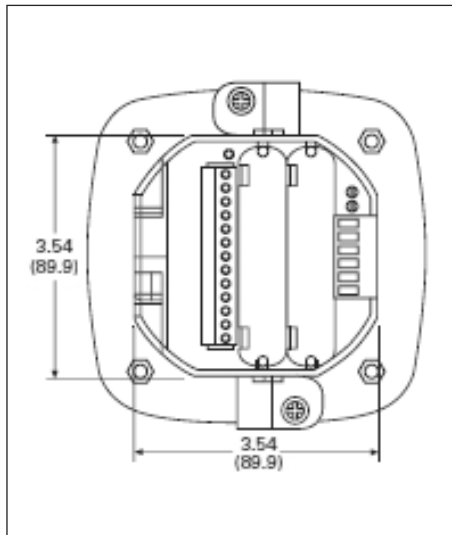

Figure 10. PXM 2000 Rear View

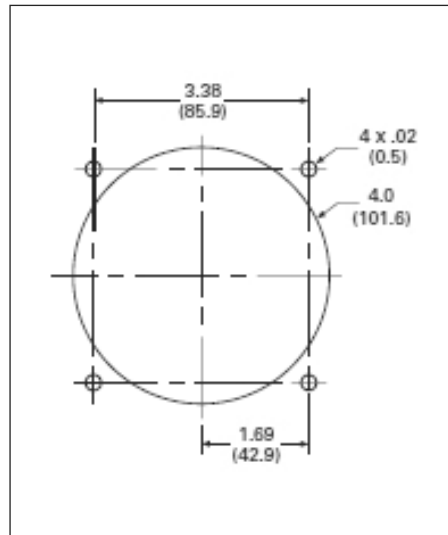

Figure 11. ANSI Mounting Panel Cutout

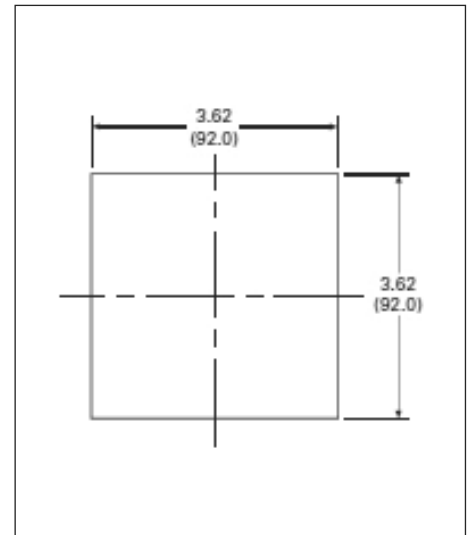

Figure 12. DIN Mounting Cutout

Ordering Information

To order a Power Xpert Meter 2000, the catalog number should be determined using the chart shown in **Table 1**. The chart illustrates how to include the desired factory options as part of a catalog number. Option cards that are selected at time of order entry will be installed at the factory. Option cards are also field installable for future upgrades.

Power Xpert meter modules include panel mounting brackets.

Example 1: PXM2270MA65145 (PXM 2270 Meter/Display 60 Hz, 5 Amp, 90 – 265 Vac/dc W/4AO).

Example 2: PXM2250MA65105 (PXM 2250 Meter/Display 60 Hz, 5 Amp, 90 – 265 Vac/dc).

Table 1. Power Xpert Meter 2000 Catalog Numbering System

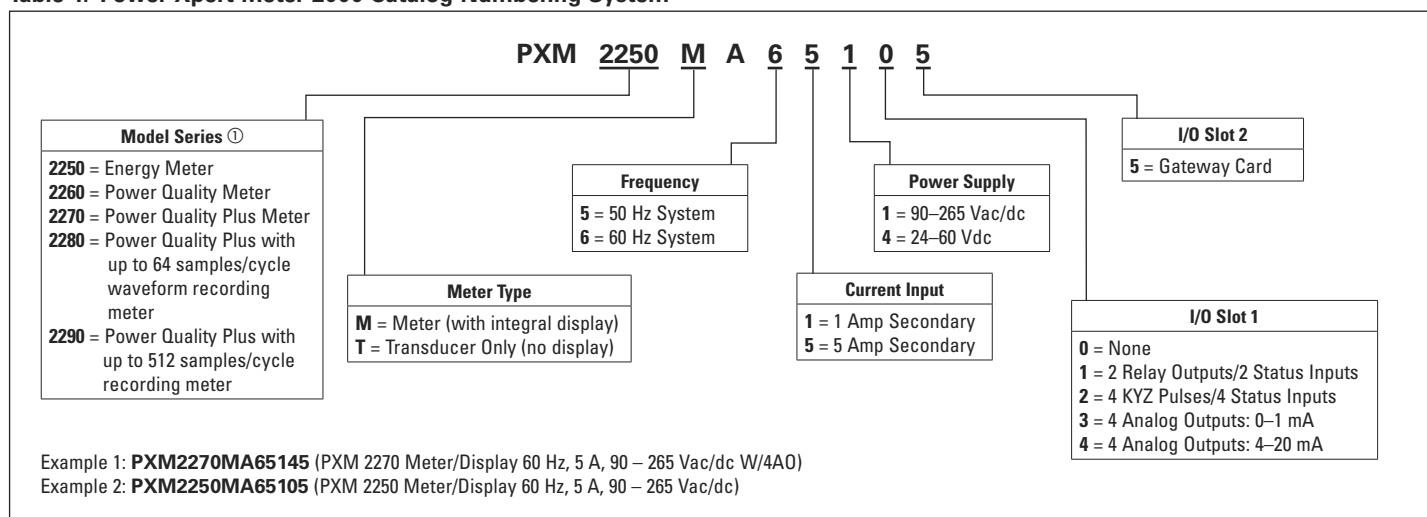

① Refer to **Table 3** for model-specific features.

Table 2. Power Xpert Meter 2000 Accessories

Description	Catalog Number
Panel Mounting Bracket Assembly for Retrofitting a PXM 2000 to an IQ Analyzer/IQ DP4000/IQ Data Cutout	IQ250-PMAK
PXM 2000 Gateway Card Kit to Upgrade an IQ 250/260 to a PXM 2000	PXM2000-GCK

Table 3. Power Xpert Meter 2000 I/O Cards

Description	Catalog Number
PXM 2000 I/O Card-2 Relay Outputs/2 Status Inputs	IQ250/260-I01
PXM 2000 I/O Card-4 KYZ Pulses/4 Status Inputs	IQ250/260-I02
PXM 2000 I/O Card-4 Analog Outputs - 0–1 mA	IQ250/260-I03
PXM 2000 I/O Card-4 Analog Outputs - 4–20 mA	IQ250/260-I04

PXM 2000 Series Electronic Power Meter Technical Information

Current Inputs

- Class 10: 5 amp nominal, 10 amp maximum.
- Class 2: 1 amp nominal, 2 amp maximum.
- Fault current withstand:
 - 100 amps for 10 seconds
 - 300 amps for 3 seconds
 - 500 amps for 1 second
- Continuous current withstand: 20 amps for screw terminated or pass-through connections.
- Programmable current: full scale to any CT ratio.
- Burden: 0.005 VA per phase maximum at 11 amps.
- Pickup Current: 0.1% of Nominal
 - Class 10: 5 mA
 - Class 2: 1 mA
- Connections:
 - Pass-through Wire Gauge Dimension: 0.177 Inches (4.5 mm)
 - Quick Connect: 0.25-Inch (6.35 mm) Male Tab

Voltage Inputs

- Range:
 - Line-to-Neutral 20 – 576 Vac
 - Line-to-Line 0 – 721 Vac
- Programmable voltage range: full scale to any PT ratio.
- Supported Systems:
 - 3 element Wye, 2.5 element Wye
 - 2 element Delta, 4-wire Delta systems
- Input impedance: 1 meg ohm/phase.
- Burden: 0.36 VA/phase maximum at 600 V; 0.014 VA at 120 volts.
- Connection: 7-pin 0.400-inch pluggable terminal block, AWG #12 – 26 (0.129 – 3.31 mm²).

Isolation

- All inputs and outputs are galvanically isolated to 2500 volts.

Environmental Ratings

- Operating temperature: -20°C to +70°C.
- Storage temperature: -20°C to +70°C.
- Operating humidity: to 95% RH non-condensing.
- Faceplate rating:
 - NEMA 12
 - Mounting gasket included

Sensing Method

- Voltage, current: true rms.
- Power: sampling at over 400 samples per cycle on all channels.
- Harmonics Resolution: 40th order.

Update Rate

- Watts, Var and VA: 100 msec at 60 Hz.
- All other parameters: 1 second at 60 Hz.

Power Supply

- AC/DC voltage option: 90 – 265 Vac at 50/60 Hz or 100 – 370 Vdc, universal AC/DC supply.
- DC voltage option: 18 – 60 Vdc.
- Burden: 10 VA Maximum.

Serial Communications Format

- Connection type: RS-485 (through back plate).
- Com port baud rate: 9600 – 57,600 bauds.
- Com port address: 01 – 247.
- Data format: 8-bit, no parity.
- Protocols: Modbus ASCII, RTU or DNP 3.0.

Network Communications Format

- Connection type: RJ-45 10/100Base-T Ethernet Network port.
- Protocols: Ethernet TCP/IP, Modbus TCP, BACnet/IP, HTTP, HTTPS, NTP, SMTP, SNMP

KYZ Pulse

- Contacts: 1 Form A.
- On resistance, maximum: 35 ohms.
- Peak switching voltage: 350 Vdc.
- Continuous load current: 120 mA.
- Peak load current: 350 mA (10 ms).
- Off-state leakage current at 350 Vdc: 1 uA.
- Opto-isolation: 3750 Vac.

Dimensions and Shipping

- Weight: 2 lbs. (0.91 kg).
- Basic Unit: H 5.00 x W 4.90 x L 5.00 Inches (H 127.0 x W 124.5 x L 127.0 mm).
- PXM 2000 Series: mounts in 3.62-inch (92.0 mm) DIN and ANSI C39.1 round cut-outs.
- Shipping container dimensions: 6-inch cube.
- Tolerance: +/-0.1 inches (2.54 mm).

Compliance

- IEC/EN60687: 0.2% accuracy.
- ANSI C12.20: 0.2% accuracy.
- ANSI C62.41: burst.
- UL/cUL: Electrical & Electronic Measuring & Test Equipment 22CZ.
- CE.

Power Xpert Meter 2250

- Measures basic meter parameters.
- 256 MB for data logging.
- Ethernet.
- On-board gateway card limits/alarms.

Power Xpert Meter 2260

Features of PXM 2250 plus:

- Harmonics.
- On-board meter hardware limits to activate optional relay outputs.
- Visual indication of limits exceeded at meter face.
- 512 MB for data logging.

Power Xpert Meter 2270

Features of PXM 2260 plus:

- Harmonics, including individual.
- Waveform view to visualize steady-state harmonic content.
- 768 MB for data logging.

Power Xpert Meter 2280

Features of 2270 plus:

- Up to 64 samples per cycle waveform recording.
- Configuration of total, pre- and post-event cycles.

Power Xpert Meter 2290

Features of 2280 plus:

- Up to 512 samples per cycle for waveform recording.

Table 4. Power Xpert Meters 2250/2260/2270/2280/2290 – Features and Benefits

Feature	Power Xpert Meter					Benefit
	2250	2260	2270	2280	2290	
General						
Embedded Web Server	•	•	•	•	•	Use a standard Web browser to monitor and manage the meter over the network.
Firmware Flash Update Support	•	•	•	•	•	Enables you to flash the meter with the latest firmware updates.
Power, Energy and Demand						
Voltage, Current: per Phase Minimum, Maximum, Average, Trend Graph Analysis, Export, Print	•	•	•	•	•	Review voltage and current trends, export, print and analyze parameters right on the meter or external software.
Demand: Forward, Reverse, Net Sum, Profile, Export, Print, Plot Comparisons Month-to-Month, Week-to-Week	•	•	•	•	•	Plot two months or two weeks for vivid demand comparison, receive emails with trend logs.
Power, Apparent, Real, Reactive, Power Factor	•	•	•	•	•	Review power usage and power factor and avoid potential PF penalties.
Energy: Forward, Reverse, Net, Sum	•	•	•	•	•	Keep track of your energy usage, identify peaks to conserve energy usage, receive emails with trend logs.
Power Quality Analysis						
Statistical Analysis (min, max, average)	•	•	•	•	•	Review statistical trends, identify past and future problem areas.
Sampling Rate, Maximum Samples/Cycle	400	400	400	400	400	High sampling rate resulting in high accuracy.
Security						
Secure 2 Level User Access Privileges	•	•	•	•	•	Define appropriate security access level per user.
Communications						
Modbus TCP	•	•	•	•	•	Easy integration with standard protocol to power management and other software.
Modbus RTU	•	•	•	•	•	Integrate meters to existing Modbus networks, daisy chain several (1 – 32) meters together.
BACnet/IP	•	•	•	•	•	Easily integrate into existing building management systems without the need for external protocol adapters
HTTP, HTTPS	•	•	•	•	•	Communicate to the meter over the Internet via standard Web browser.
SNMP (Simple Network Management Protocol)	•	•	•	•	•	Communicate with the meter via Simple Network Management Protocol; hook to existing NMS system.
SMTP (Simple Mail Transfer Protocol)	•	•	•	•	•	Send e-mail messages via standard Simple Mail Transfer Protocol.
NTP (Network Time Protocol)	•	•	•	•	•	Network Time Protocol support enables the meter to synchronize its time over the network.
DNP 3.0	•	•	•	•	•	Easy integration with DNP networks (serial).
Trend Measurements CSV File Export	•	•	•	•	•	Easily export trend measurements to third-party applications, in standard CSV file format.

Table 4. Power Xpert Meters 2250/2260/2270/2280/2290 — Features and Benefits (Continued)

Feature	Power Xpert Meter					Benefit
	2250	2260	2270	2280	2290	
Logs						
Trend Logging	•	•	•	•	•	Log trend information for easy statistical analysis.
Load Profile	•	•	•	•	•	Review the load profile graph to get a better understanding of your electrical load versus time.
Event Logging	•	•	•	•	•	Log events for retrospective event analysis.
Memory and Storage						
Memory, MB	256	512	768	768	768	Store trend data and events for historical analysis.
Harmonics						
Harmonic levels		40th	40th	40th	40th	Allows you to identify potential harmful harmonics.
Total Harmonic Distortion (THD)		•	•	•	•	Review the total harmonic distortion level directly on the meter.
Individual Harmonics			•	•	•	Provides simple metric for power quality viewable from the embedded Web server.
Waveform						
Waveform Display			•	•	•	A single-cycle waveform view on a PC, through embedded Web server, to visualize steady-state harmonic content to identify power quality issues.
Waveform Recording				64	512	Ability to record waveforms up to specified samples/cycle.
I/O						
I/O 2 Relay Outputs/2 Status Inputs 4 KYZ Pulses/4 Status Inputs 4 Analog Outputs 0-1 mA 4 Analog Outputs 4-20 mA	Opt.	Opt.	Opt.	Opt.	Opt.	The Power Xpert Meter 2000 I/O Cards are extremely flexible and can be used in a large variety of different applications. Digital inputs and relay outputs can be programmed to interact during various conditions defined by the user. Various third-party devices, such as alarms, pulse meters, trip units and sensors, can be easily integrated to the Power Xpert Meter 2000. Triggers and events can be tied to the meter's standard functions such as e-mail, logs and trends. Analog outputs can be programmed to output meter parameters to BMS or PLC systems.

Note: These specifications are subject to change without notice and represent the maximum capabilities of the product with all options installed. This is not a complete feature list. Features and functionality may vary depending on selected options, firmware version and product model. Please refer to the technical data sheet and User Manual for detailed specifications.

Eaton Corporation
 Electrical Sector
 1111 Superior Ave.
 Cleveland, OH 44114
 United States
 877-ETN-CARE (877-386-2273)
 Eaton.com/meters

© 2011 Eaton Corporation
 All Rights Reserved
 Printed in USA
 Publication No. TD02601017E / TN
 December 2011



Eaton and Power Xpert are registered trademarks of Eaton Corporation.

All other trademarks are property of their respective owners.