

# Power Xpert® Meter 2000 Gateway Card Kit

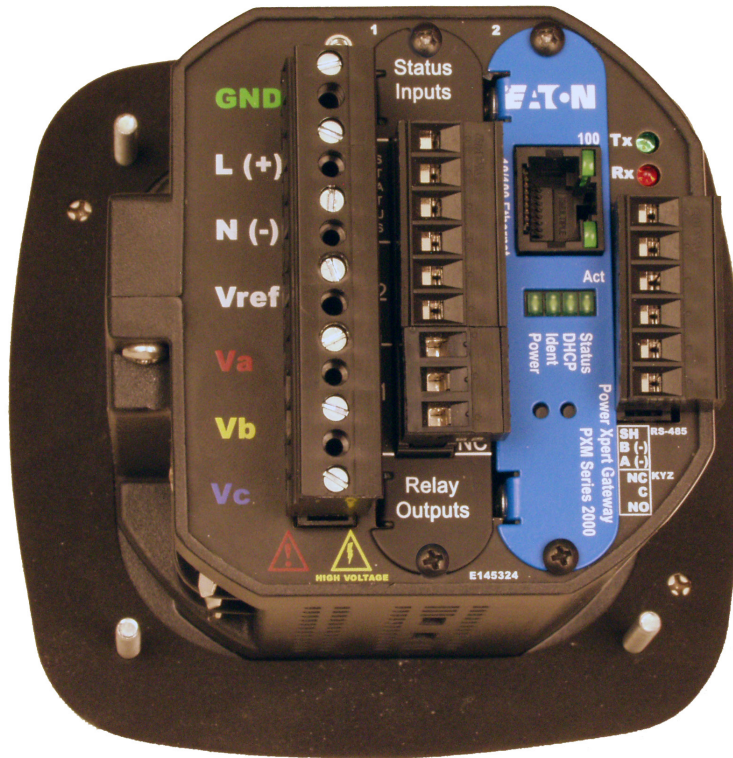

## Table of Contents

Remove the Meter From Service . . . . .	2
Disconnect Power Connections, CTs, and Modbus . . . . .	2
Remove Meter from Panel. . . . .	2
Locate the Meter on the Bench. . . . .	2
Install the Gateway Card. . . . .	3
Check Meter Firmware . . . . .	4
Connect to the Meter for Firmware Upgrade . . . . .	4
Upgrade the Firmware. . . . .	4
Configure the Gateway Card . . . . .	5
Check Gateway Card Indicators . . . . .	5
Configure Network Access for the Gateway Card using a Local PC. . . . .	5
Verify the IP Address . . . . .	7
Network Access. . . . .	7
If You Need to Restart The Gateway Card . . . . .	7
Additional Information . . . . .	8
Reinstall the Meter . . . . .	8



Powering Business Worldwide

## Remove the Meter From Service

Turn power off at the breaker feeding the meter. There may be more than one breaker. Use local safety procedures such as "Lock out/Tag out" to ensure the breaker(s) is not inadvertently energized.

Ensure the high power connections on the meter are de-energized.

- Current sensing wires may be connected directly to the load by simply passing the current carrying conductors (load or Current Transformers) directly through the meter. There is no physical connection to the meter.
- Current sensing wires may be connected directly to the meter by attaching the current carrying conductors to "current gills" or quick connect terminals on the meter.

Then remove or disconnect the current sensing wires from the meter.

### **⚠ WARNING!**

**USE CAUTION TO ENSURE THE CURRENT THROUGH THE CTS IS OFF OR SUITABLE PROTECTION IS IN PLACE TO PREVENT CONTACT WITH THE LEADS FROM THE CT.**

**ENSURE THE CONTROL OR LOGIC POWER TO THE METER IS DE-ENERGIZED. THE VOLTAGE AT THESE TERMINALS IS THE LOCAL AC VOLTAGE.**

### Disconnect Power Connections, CTs, and Modbus

1. Remove the large 13 position connector on the back of the meter.
2. If the installation is being done on an operational meter, this connector must be removed before installing the Gateway Card. Removing this connector will remove power to the meter. The Gateway Card is not designed to be hot-pluggable (installed with power on).
3. If an extra 13 position connector is not available, make note of where the wires are connected to the 13 pin connector. You will need this information when re-connecting the wires. Then remove the wires from the 13 position connector and replace the connector into the meter.

**Figure 1. 13 and 6 position connectors**

13 position  
connector

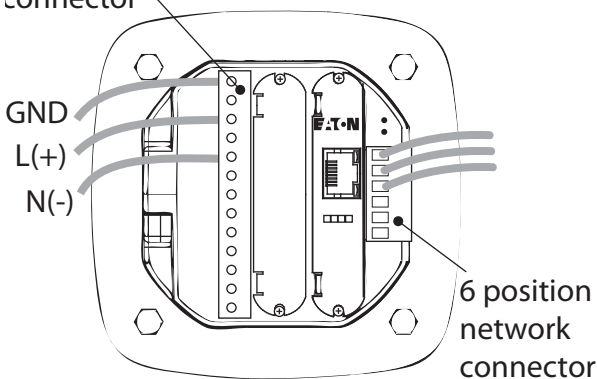

### Remove Meter from Panel

When removing the meter keep the mounting hardware (screws, washers, etc.) in a safe place for use when re-installing the meter.

For ANSI installations remove the four nuts and washers.

**Figure 2. Removing the four nuts and washers**

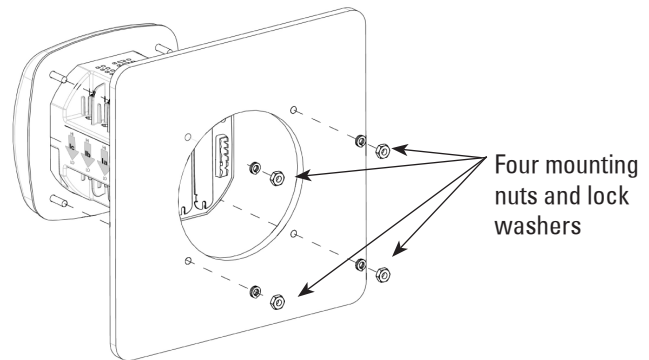

For DIN installations remove the two screws and mounting brackets.

**Figure 3. Removing the DIN mounting brackets**

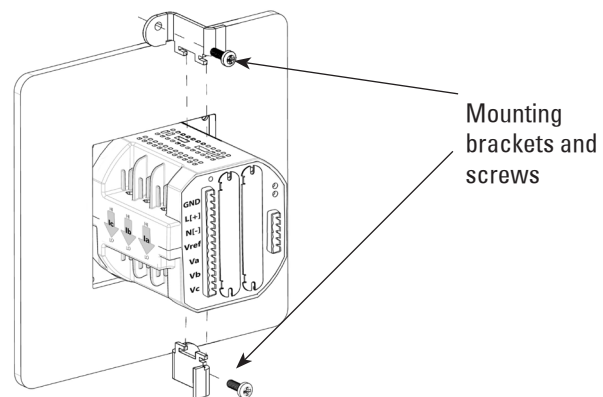

For DIN rail installations pull down on the mounting clips to release the meter.

**Figure 4. Transducer version of meter mounted on DIN rail**

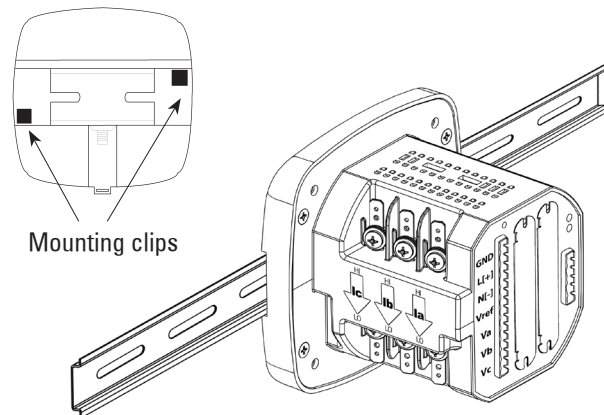

### Locate the Meter on the Bench

The installation procedure requires local power and an active Ethernet connection. To provide power to the meter, it may be useful

to build an Aux cable to GND, L(+) and N(-) using a 13 position connector. This is particularly useful if installing many Gateway Cards.

The Gateway Card must be installed in slot 2. If slot 2 is occupied, remove the card in slot 2 and place it into slot 1. Otherwise, remove the option card cover over slot 2. Retain the screws.

### Install the Gateway Card

**CAUTION!**

**USE LOCAL ELECTROSTATIC DISCHARGE PROTECTION OR TOUCH A SUITABLY GROUNDED METAL SURFACE TO DISCHARGE ANY STATIC ELECTRICAL CHARGE. FAILURE TO FOLLOW THESE GUIDELINES COULD CAUSE DAMAGE TO THE GATEWAY CARD.**

1. Remove the Gateway Card from the protective wrap.
2. Locate the MAC address printed on the card. Record it here.  
MAC Address: \_\_\_\_\_

The MAC address is on a small label and consists of 14 letters and numbers. It looks something like: 0020808500EF

3. Another MAC address label is included in that kit and should be applied to the flat area on top of the meter (above the meter's information label).

**Figure 5. Area for MAC address label**

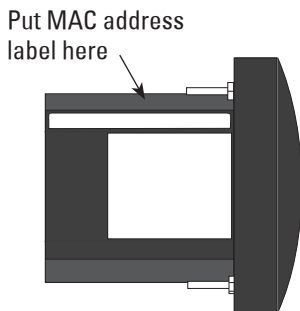

4. Verify the switch settings on the card. All switches should be in the off position.

**Figure 6. Card Switches Shown in the Off Position**

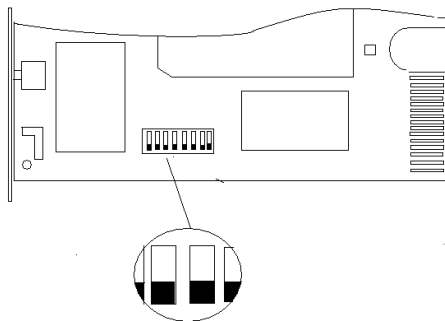

5. Insert the Gateway Card into meter slot 2 using the meter's built-in card guides (see the following figure). Use care to correctly locate the card in the guides. Slide the card carefully into the meter until it stops. Gently push on the card until it "clicks" into place.

**Figure 7. Install Gateway Card into slot 2**

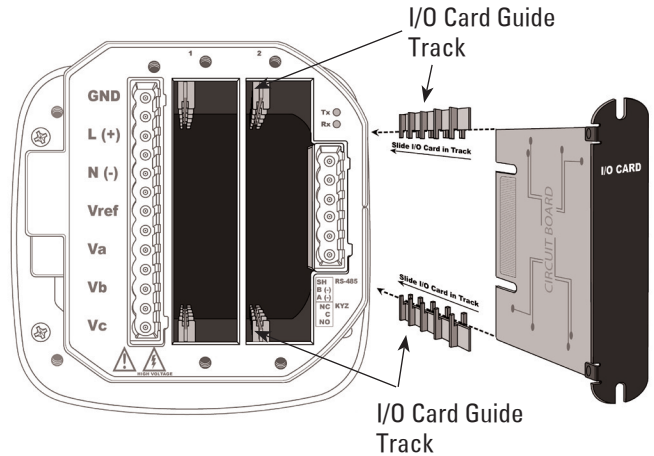

6. Secure the card by replacing the screws removed while removing the cover.
7. If available, connect the building Ethernet cable to the jack on the Gateway Card. Otherwise use a local Ethernet equipped PC and the seven-foot Ethernet cable shipped with this kit.
8. If available, connect the Modbus connector (6 position connector) that is attached to the Modbus network.
9. Attach the power cord. If an AUX power cord was assembled then insert the connector into the socket. Otherwise connect GND, L(+) and N(-) to the 13 position connector as indicated in the figure on page 2.
10. Apply power to the power cord.
11. There are four indicator LEDs on the Gateway Card labeled: **Status**, **DHCP**, **Ident**, and **Power**. When power is first applied all the lights should be off for a few seconds and then the **Power** light will illuminate. This indicates the card has power and is running.
12. There are two lights (LEDs) located on the Ethernet cable jack. If the Ethernet cable has an active Ethernet connection the light labeled Act may be flickering. The light labeled 100 will be lit if the Ethernet connection is active at 100 Mbps.

Figure 8. Location of LEDs

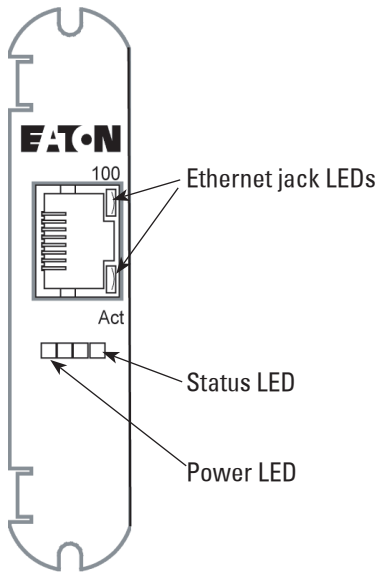

### Check Meter Firmware

If the meter firmware is lower than version 14, you must upgrade the firmware. You can check the firmware version of a powered meter from the front panel.

1. Press MENU.
2. Press the down button until **INF** is flashing (line A).
3. Press ENTER.
4. An initial three-line display of values appears. After a few seconds, a second set of values appears. The firmware version number is in the middle line.
5. If the meter firmware version is 14 or greater, you do not need to upgrade the firmware and can proceed to *Configure the Gateway Card* on page 5.
6. If you must upgrade the firmware, continue on with this procedure.
7. Press MENU.
8. Press the down button until **CFG** is flashing (line A).
9. Press ENTER.
10. Press the down button until **PD+** is flashing (line A).
11. Press ENTER.
12. The **Ad-** (address) screen appears. Record the address:
13. Address \_\_\_\_\_
14. Press ENTER. The **BAUD** screen appears. Record the baud rate:
15. Baud rate: \_\_\_\_\_
16. Press MENU twice.

### Connect to the Meter for Firmware Upgrade

This procedure requires an RS-232 to RS-485 serial adapter, as you must connect to the meter through the RS-485 port.

1. Place the CD that accompanied your upgrade kit into the PC's CD/DVD drive.
2. Install the Eaton Meter Configuration Software (double-click EatonMCSSetup.exe in the root folder of the Eaton Meter Configuration Software CD).
3. After installation, launch the Configuration Software.

4. Click the **Connect** icon on the title bar or **Connection > Quick Connect**.
5. Make sure the **Serial Port** radio button is selected.
6. Enter the **Device Address** you previously recorded.
7. Select **Baud Rate** you previously recorded from the pull-down menu.
8. Select the port you are using from the pull-down menu. The **Available Ports/All Ports** radio buttons determine which port selections the menu displays.
9. Select **Modbus RTU** from the **Protocol** pull-down menu.
10. Select **Flow Control: None**.
11. Select **Echo Mode: No Echo**.

Figure 9. Connection screen

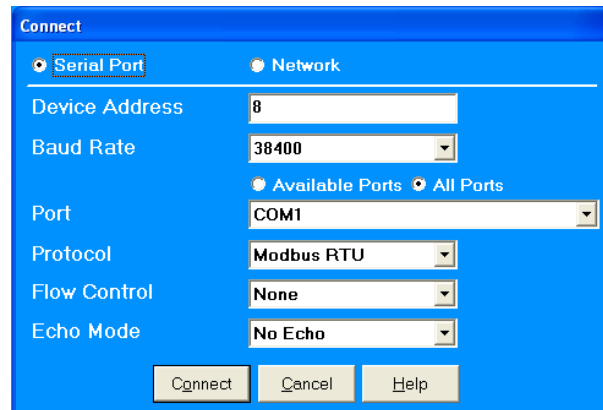

12. Click the **Connect** button. You will see the **Device Status** screen.

Figure 10. Device Status Screen

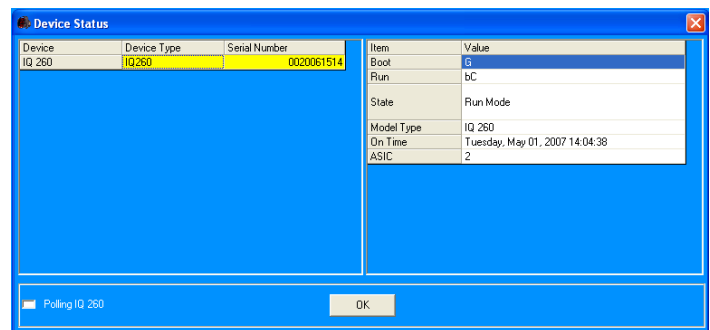

### Upgrade the Firmware

1. At the Eaton Meter **Configuration** screen, select **Tools > Flash Me**. You will see the following screen.

Figure 11. Firmware Update Dialog Box

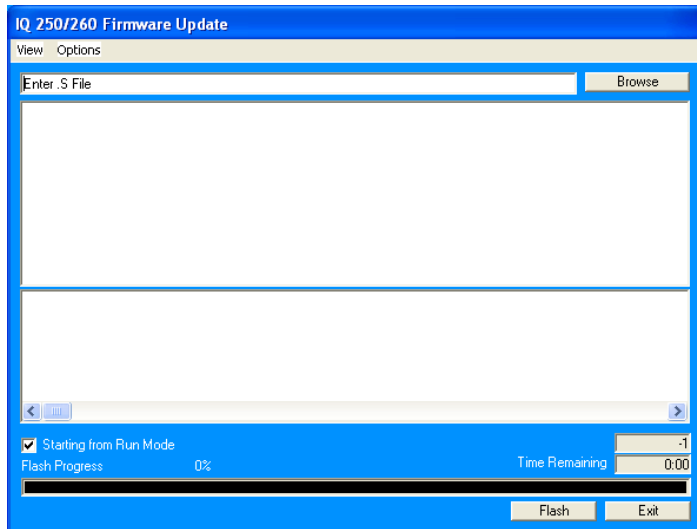

2. Click **Browse** to locate the firmware update file on the CD.
3. Click **Flash** to update the firmware.
4. When the update is complete, click **Exit** to close the screen.

**Note:** If Flash Update fails, you will see a message to that effect. Check Device Status to see if your meter is in Boot Mode.

- If the meter is in Boot Mode, clear the **Starting from Run Mode** box in the **Flash Me** screen and try flash updating the firmware again.
- If the meter’s status is not displayed in the **Device Status** screen, the meter may be stuck in Boot Mode. If you are certain the communication settings are correct for the meter, try connecting to the meter using the following defaults:

Address	001
Baud Rate	9600
Protocol	Modbus RTU

Once you connect to the meter, you can try flash upgrading again. This concludes the firmware update. You can now proceed to configure the Gateway Card.

### Configure the Gateway Card

An Ethernet connection is used for configuring the meter’s Gateway Card communication settings via a web browser. You may need to contact your network administrator for some network and configuration information. In preparation, you will need to decide if the meter will be manually assigned a fixed (static) IP address or will be automatically assigned a fixed IP address by a DHCP server somewhere on the network. With either method the assigned network address must not change once the meter has been deployed. Changing the IP address will cause loss of communication until the associated client PCs change the corresponding meter’s IP addresses.

Discuss with your network administrator whether you should manually configure the meter with a static IP address (the default) or whether the DHCP server will assign one. For the DHCP server to provide a fixed IP address, your network administrator will need to know the MAC address assigned to the meter.

### CAUTION

**EATON STRONGLY RECOMMENDS USING A FIXED IP ADDRESS (THE DEFAULT) IF AN EATON PXS SYSTEM WILL BE ACCESSING THE METER. OTHERWISE,**

### **SHOULD THE IP ADDRESS CHANGE (AFTER A POWER OUTAGE, FOR EXAMPLE), PXS WILL NO LONGER BE ABLE TO ACCESS DATA FROM THE METER.**

Is DHCP going to be used to assign the IP address to your meter?  
 Yes  No

**If Yes:**

Provide the MAC address (previously noted on page 3) to the network administrator and record the fixed IP address the network administrator will assign to your meter in the DHCP server here:

IP Address: \_\_\_\_\_

The card will be configured remotely. Skip to the section entitled *Verify the IP address*

**If No:**

Record the following information provided by the network administrator here:

IP Address: \_\_\_\_\_

Subnet Mask: \_\_\_\_\_

Default Gateway: \_\_\_\_\_

Primary DNS Server IP Address \_\_\_\_\_

Secondary DNS Server IP Address \_\_\_\_\_

### Check Gateway Card Indicators

First, ensure power is applied to the meter.

There are four indicator LEDs on the Gateway Card labeled: **Status**, **DHCP**, **Ident**, and **Power**. When power is first applied all the lights should be off for a few seconds and then the **Power** light will illuminate. This indicates the card has power and is running.

### Configure Network Access for the Gateway Card using a Local PC

Your network administrator either provided an IP address, a subnet mask, and a default gateway (which you entered in the previous section) or has decided to assign an address via DHCP. This information must be entered into the Gateway Card using a local PC, such as a laptop.

This method requires a PC with the following:

- an Ethernet port
- an Ethernet cable (a seven-foot cable is provided in the kit)
- a Java-enabled web browser, such as Microsoft Internet Explorer versions 7, 8, or 9.
- an installed version 6 or greater JAVA J2SE JRE (Java Runtime Environment). If not already installed, when you connect to the meter you’ll be given the option to navigate to the Sun Java website and download the JRE.

1. On the PC, launch the **Java Control Panel** screen (available through the Windows **Control Panel**).
2. On the **General** tab, click the **Settings** button under **Temporary Internet Files**.

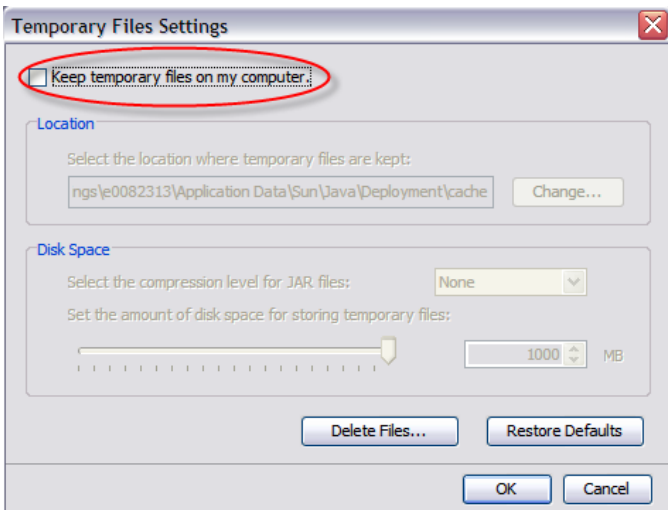

Figure 12. Settings Button



3. Ensure the Keep Temporary Files on My Computer check box is cleared.

Figure 13. Keep Temporary Files on My Computer check box



4. Connect the PC to the Gateway Card through the seven-foot Ethernet cable shipped with the kit.

There are two green lights (LEDs) located on the Gateway Card's Ethernet port. If the Ethernet cable is connected to an active Ethernet port on the PC both lights should be illuminated (the light labeled **Act** may be flickering reflecting network activity).

5. The card's default Ethernet IP address is 192.168.1.1. Set the PC's address to an address on the same subnet, such as 192.168.1.100.

To do this, use the following steps:

1. Click Window's **Start**.
2. Choose either **Settings > Control Panel** (Windows 2000) or **Control Panel** (Windows XP).
3. In the **Control Panel**, click **Network Connections** and right-click **Local Area Connection**. Select **Properties** from the shortcut menu.
4. Click the **Properties** button.
5. In the **Properties** dialog box, select **Internet Protocol (TCP/IP)** and click the **Properties** button.
6. In the **Internet Protocol (TCP/IP) Properties** dialog box, select **Use the following IP address** and enter the following in the **IP address** field: **192.168.1.100**
7. Click **OK** throughout the various dialog boxes.

6. Launch your Java-enabled web browser and navigate to the following IP address: **192.168.1.1**

If an information screen appears stating the certificate cannot be verified and asking if you want to run anyway, select **run**.

Java will load and then the meter's **Home** page will appear.

Figure 8. Loading Page

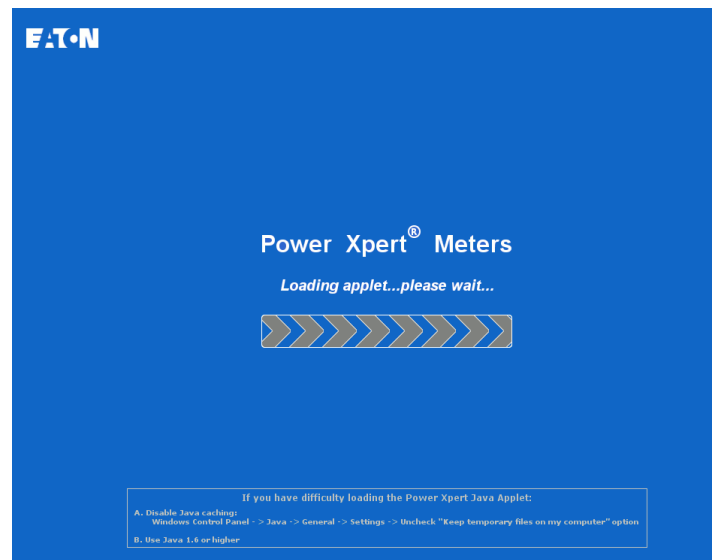

7. Click the **Setup** button or the **Setup Meter** link. The **Setup** page will appear.

Figure 9. Meter Home Page

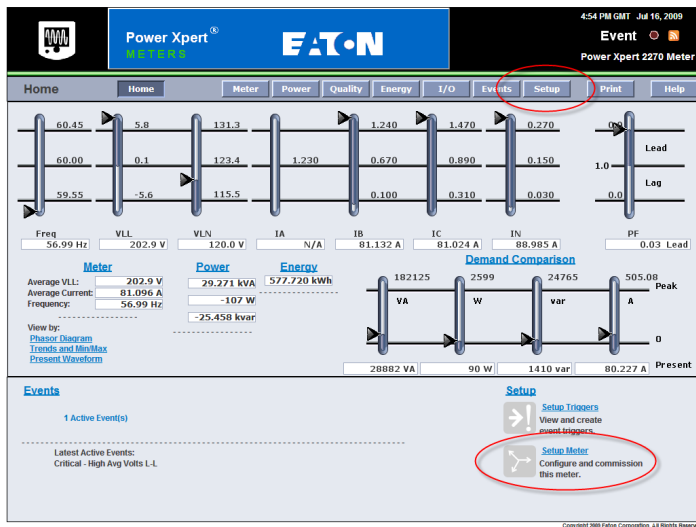

8. Locate and click the open icon to the left of the Quick Setup folder. The folder opens to show two subfolders: Meter and Network.

Figure 10. Opening the Quick Setup Folder

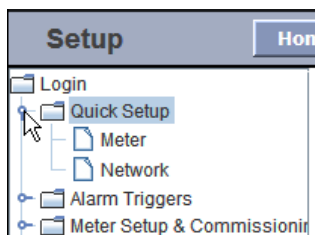

9. Click the Network folder.

10. Click the Edit button.

Figure 11. Edit Button (on the right of the page)

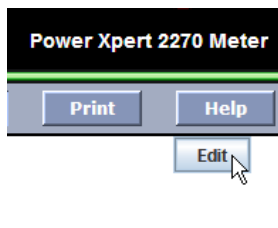

11. A Login dialog box appears.

12. The default Username is admin and the default Password is admin. Log in using these credentials.

Figure 12. Login dialog

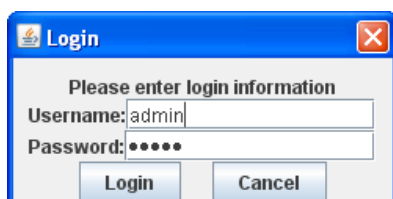

13. Configure the card for the settings specified by your network administrator. You can also enter such optional information as the meter's location, who to contact in case of problems, etc.

14. When you've completed configuration, click the OK button.

15. The new IP address will take effect shortly after clicking OK. Communication with the PC will then be lost. You can continue to configure the meter after it is connected to your LAN.

16. Refer to the *PXM 2000 Meter User and Installation Guide (IM02601001E)* for additional configuration details.

17. Disconnect the Ethernet cable to the PC and connect the meter to the LAN.

**Note:** Remember to reconfigure the PC's network settings for your LAN.

**Verify the IP Address**

1. If the meter has power the display should be showing normal data, such as voltage, current, etc.
2. Push the MENU button on the face of the meter. The main menu screen appears.
3. Push DOWN repeatedly until IP blinks.
4. Push ENTER and the meter's IP address appears, which should appear something like the following:

010.222.051.066

In this example the IP address is 010.222.051.066. This should match the address the network administrator provided for this meter.

5. Push MENU to return to the main menu.

**Network Access**

Once the network IP address is known, most meter functions and configuration can be done via the network. Use a networked client PC running version 6 or greater of the JAVA J2SE JRE and a Java enabled browser such as Internet Explorer version 7, 8, or 9 to navigate to the meter's IP address. See the meter's complete user's manual for additional information.

**If You Need to Restart The Gateway Card**

You can restart the Gateway Card through a momentary push-button switch accessed through a small hole in the face plate of the Gateway Card. Although this is not used in normal operations, this switch allows you to restart the Gateway Card in the meter.

The Gateway Card restart push-button switch is located behind the hole in the card face plate closest to the LED labelled DHCP. This switch is used to restart just the Gateway Card (not the meter) should it be necessary to recover from some abnormal condition.

Momentarily press the switch by pushing a small device into the hole to activate the switch.

**Note:** It may take around five minutes before the meter pages begin to display values.

Figure 13. Reset Switch

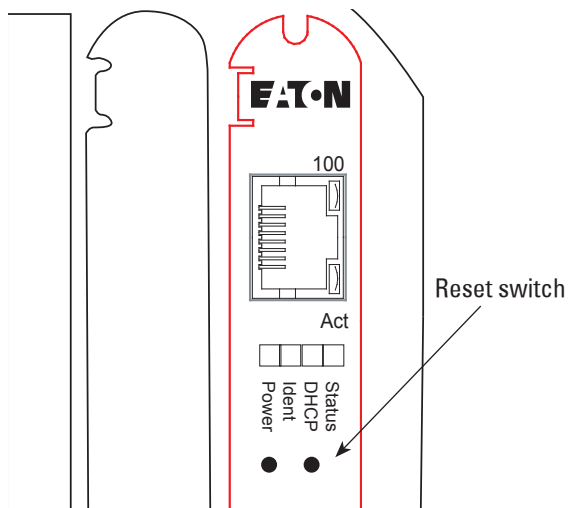

### Additional Information

Detailed information on applications and options can be found in the *PXM 2000 Meter User and Installation Guide (IM02601001E)* on the CD shipped with the meter. The guide can also be found at <http://www.eaton.com/powerxpert>.

### Reinstall the Meter

Refer to the meter documentation for a more detailed description of installing and wiring the meter. The following is merely an overview of the steps you'll need to perform.

1. Turn power off to the 13 position connector. If an AUX cable was used then remove the 13 position connector. Else, disconnect the GND, L(+), and L(-) wires from the 13 position connector. See the figure on page 2.
2. If a Modbus network was connected remove the six position network connector.
3. Return the meter to the mounting panel using any hardware removed in previous steps. See the figures on page 2.
4. Reconnect the current sensing (CT or direct connections) wires.
5. If an AUX cable was not used, reconnect the wires to the 13 position connector. Otherwise plug the wired connector into the meter.
6. Reconnect the Modbus network using the six position Modbus connector.
7. Insert the Ethernet cable into the socket on the new Gateway Card. Be sure to route the cable away from any high voltage wires. Secure the cable in compliance with local electrical codes.
8. Take any necessary safety precautions in preparation for restoring power.
9. Turn the power on at the breaker(s).
10. Watch the LEDs on the back of the Gateway Card. They should all turn off for a few seconds and then the right (Status) and the left (Power) lights should be illuminated to indicate the card has power and has started correctly. See the figure on page 4 for the location of the LEDs.

**Eaton Corporation**  
Electrical Group  
1000 Cherrington Parkway  
Moon Township, PA 15108  
United States  
877-ETN-CARE (877-386-2273)  
Eaton.com

© 2011 Eaton Corporation  
All Rights Reserved  
Printed in USA  
Publication No. IL02601011E  
December 2011