

# Power Xpert Meter 1000 Series

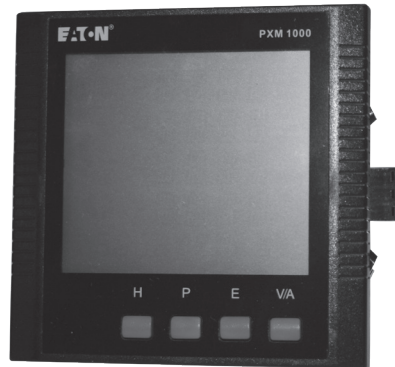

## General description

The Power Xpert® Meter 1000 Series power and energy meters monitor the most critical aspects of an electrical distribution system. This premier metering instrument uses the latest in advanced technology to make it simple to use, powerful, scalable, and highly flexible.

## Applications

Identify power quality problems to help:

- Protect motors from damage
- Preserve the integrity of processes and batches
- Prevent blown capacitor bank fuses
- Protect transformers and conductors from overheating

Monitor circuit loading to help:

- Avoid overloads and nuisance overload trips
- Maximize equipment utilization
- Manage emergency overloads

Manage energy utilization to help:

- Reduce peak demand charges and power factor penalties
- Identify excessive energy consumption

## Features

- 100 ms refresh, true rms measurement
- ANSI C12.20 (0.2 Class) and IEC 62053-22 (0.2S Class)
- Up to 16 MB onboard memory
- Power quality analysis
- Over/under limit alarm
- RS-485 communication port
- Supports Modbus® RTU, DNP 3.0
- Switch status monitoring
- Waveform capture
- Measure individual harmonics from 2nd to 63rd
- Physical anti-tampering seal
- 50/60 Hz and 400 Hz rated frequency metering
- Modular design
- Data logging
- TOU (time of use), 4 tariffs, 12 seasons, 14 schedules
- Optional Modbus TCP and BACnet/IP communications modules available with Web/HTTP push

**EATON**

Powering Business Worldwide

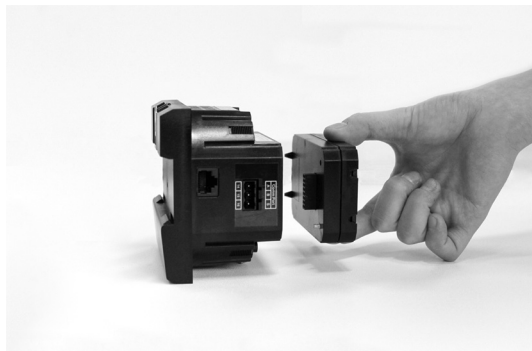

### Metering

- Voltage V1, V2, V3, VLnavg, V12, V23, V31, VLLavg
- Current I1, I2, I3, In, lavg
- Power P1, P2, P3, Psum
- Reactive power Q1, Q2, Q3, Qsum
- Apparent power S1, S2, S3, Ssum
- Frequency F
- Power factor PF1, PF2, PF3, PF
- Energy Ep\_imp, Ep\_exp, Ep\_total, Ep\_net, Epa\_imp, Epa\_exp, Epb\_imp, Epb\_exp, Epc\_imp, Epc\_exp
- Reactive energy Eq\_imp, Eq\_exp, Eq\_total, Eq\_net, Eq\_a\_imp, Eq\_a\_exp, Eq\_b\_imp, Eq\_b\_exp, Eq\_c\_imp, Eq\_c\_exp
- Apparent energy Es, Esa, Esb, Esc
- Demand Dmd\_P, Dmd\_Q, Dmd\_S, Dmd\_I1, Dmd\_I2, Dmd\_I3
- Load features
- Four quadrant power

### Features

#### Monitoring

- Power quality
- Voltage harmonics 2nd to 63rd and THD
- Current harmonics 2nd to 63rd and THD
- 400 Hz type, only support 2nd to 15th
- Voltage crest factor
- Telephone Interference Factor (TIF)
- Current K factor
- Voltage unbalance factor U\_unbl
- Current unbalance factor I\_unbl
- Max./min. statistics with time stamps

#### Alarms

Limits can be set for up to 16 indicated parameters and can be set with a specified time interval. If any input of the indicated parameters is over or under its setting limit and persists over the specified time interval, the event will be recorded with time stamps and trigger the alarm DO output. The 16 indicated parameters can be selected from any of the 80 parameters available.

#### I/O option module

A maximum of three modules can be used for one meter.

#### Anti-tampering seal

Users can physically seal the meter similar to a utility meter in order to provide anti-tampering protection. All metrological programming and user-defined parameters are protected with a physical seal.

#### High frequency metering

Designed for use with 400 Hz aircraft systems, PXM 1000 series power meters effectively monitor aircraft ground power units.

#### Data logging

PXM 1100/1200/1300 offers three assignable historical logs where the majority of the metering parameters can be recorded. The onboard memory is up to 16 MB and each log size is adjustable. A real-time clock allows for any logged events to be accurately time stamped.

#### Time of use

Users can assign up to four different tariffs (sharp, peak, valley, and normal) to different time periods within a day according to the billing requirements. The PXM 1200 meter will calculate and accumulate energy to different tariffs according to the meter's internal clock timing and TOU settings.

#### Waveform capture

PXM 1300 can record 100 groups of voltage and current waveforms. It provides the waveform record of 10 cycles before and after the triggering point. It also supports a settable triggering condition.

#### Power quality event logging

When a power quality event happens, such as voltage sag and swell, etc., PXM 1300 will record the timestamp and the triggering condition of the event. It can save up to 50,000 power quality events.

#### Automatic frequency adaptation

Rated frequency is adjusted automatically to local frequency such as 50 Hz or 60 Hz. The same meter can be used in countries with different electrical frequencies.

#### Flexible current input

Compatible with different current transformers such as 5 A, 1 A, 333 mV and Rogowski coils all available from Eaton.

#### Ports

- Dual RS-485

#### Communication protocols

- Modbus RTU
- Modbus TCP option
- BACnet/IP option
- Web/HTTP push option
- Ability to connect to Eaton's Power Xpert Gateway 900

#### Display

- Clear and large character LCD screen display with white backlight
- Wide environmental temperature endurance
- Display load percentage, four quadrant power, and load nature outline
- Small size 96 × 96 DIN or 4-inch ANSI round

**Features**

Category	Item	Parameters	PXM 1000	PXM 1100	PXM 1200	PXM 1300	
Metering	Real-time metering	Phase voltage	V1, V2, V3, VLnavg	■	■	■	■
		Line voltage	V12, V23, V31, Vllavg	■	■	■	■
		Current	I1, I2, I3, In, Iavg	■	■	■	■
		Power	P1, P2, P3, Psum	■	■	■	■
		Reactive power	Q1, Q2, Q3, Qsum	■	■	■	■
		Apparent power	S1, S2, S3, Ssum	■	■	■	■
		Power factor	PF1, PF2, PF3, PF	■	■	■	■
		Frequency	F	■	■	■	■
	Energy and demand	Energy	Ep_imp, Ep_exp, Ep_total, Ep_net, Epa_imp, Epa_exp, Epb_imp, Epb_exp, Epc_imp, Epc_exp	■	■	■	■
		Reactive energy	Eq_imp, Eq_exp, Eq_total, Eq_net, Eqa_imp, Eqa_exp, Eqb_imp, Eqb_exp, Eqc_imp, Eqc_exp	■	■	■	■
		Apparent energy	Es, Esa, Esb, Esc	■	■	■	■
		Demand	Dmd_P, Dmd_Q, Dmd_S, Dmd_I1, Dmd_I2, Dmd_I3	■	■	■	■
	TOU	Time of use	Energy/max. demand	TOU, 4 tariffs, 12 seasons, 14 schedules	—	—	■
Daylight saving time		Two adjustable formats	Month/day/hour/minute Month/week/first few weeks/hour/minute	—	—	■	—
Monitoring	Waveform capture	Voltage and current waveform*	Trigger, manual, DI change, sag/dips, swell, overcurrent	—	—	—	■
	Power quality	Voltage unbalance factor	U_unbl	■	■	■	■
		Current unbalance factor	I_unbl	■	■	■	■
		Voltage THD	THD_V1, THD_V2, THD_V3, THD_Vavg	■	■	■	■
		Current THD	THD_I1, THD_I2, THD_I, THD_Iavg	■	■	■	■
		Individual harmonics	Harmonics 2nd to 63rd (50 Hz or 60 Hz) Harmonics 2nd to 15th (400 Hz)	■	■	■	■
		Voltage crest factor	Crest factor	■	■	■	■
		TIF	Telephone Interference Factor	■	■	■	■
	Current K factor	K factor	■	■	■	■	
	Statistics	MAX with time stamp MIN with time stamp	Each phase of V & I; Total of P, Q, S, PF & F; demand of I1, I2, I3, P, Q&S; each phase THD of V & I; unbalance factor of V & I	■	■	■	■
Alarm		Over/under limit alarm	V, I, P, Q, S, PF, V_THD and I_THD each phase and total or average; unbalance factor of V and I; load type; analog input of each channel; demand of I1, I2, I3, P, Q&S; reverse phase sequence; DI1-DI28	■	■	■	■
Others	Power quality event logging	Sag/dips, swell	Voltage	—	—	—	■
Data logging	Data logging 1 Data logging 2 Data logging 3	F, V1/2/3/avg, V12/23/13/avg, I1/2/3/n/avg, P1/2/3/sum, Q1/2/3/sum, S1/2/3/sum, PF1/2/3, PF, U_unbl, I_unbl, Load Type, Ep_imp, Ep_exp, Ep_total, Ep_net, Eq_imp, Eq_exp, Eq_total, Eq_net, Es, Epa_imp, Epa_exp, Epb_imp, Epb_exp, Epc_imp, Epc_exp, Eqa_imp, Eqa_exp, Eqb_imp, Eqb_exp, Eqc_imp, Eqc_exp, Esa, Esb, Esc, THD_V1/2/3/avg, THD_I1/2/3/avg, harmonics 2nd to 63rd, crest factor, THFF, K factor, sequence and phase angles, DI counter, AI, AO, Dmd P/Q/S, Dmd I1/2/3	—	■	■	■	
	Onboard memory size	Memory	Bytes	—	8 MB	8 MB	16 MB
	Communication	RS-485 port, half duplex, optical isolated	Modbus®-RTU protocol/DNP3.0 option	■	■	■	■
Time	Real-time clock	Year, month, date, hour, minute, second	■	■	■	■	

\* The PXM1300 takes 512 samples per cycle. For the waveform capture function on the PXM1300 the sample rate is 64 samples.

## Accessories

### Digital/Analog I/O

Integrate data to/from other devices with field expandable plug-in I/O modules.

#### PXM1K-1XX

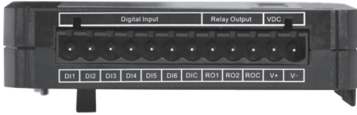

- 6x digital inputs
- 24 Vdc power for digital inputs
- 2x relay outputs

#### PXM1K-2XX

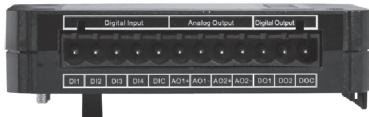

- 4x digital inputs
- 2x digital outputs
- 2x analog outputs

#### PXM1K-3XX

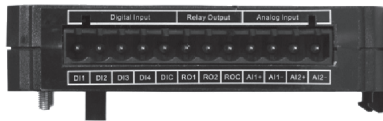

- 4x digital inputs
- 2x relay outputs
- 2x analog inputs

### Panel mount remote display

PXM 1000 panel mount remote display for DIN rail mount transducer version (PXM1000 T). Includes one 6 ft cable.



### Communications Modules

#### PXM1K-MTCPP / PXM1K-BIPP



- Modbus TCP
- Web/HTTP push
- BACnet/IP (only on PXM1K-BIPP)

### Meter input wiring

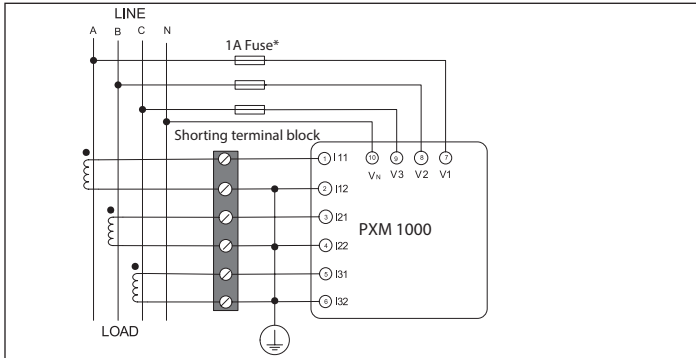

Figure 1. Three-phase, four-wire (3LN, 3CT)

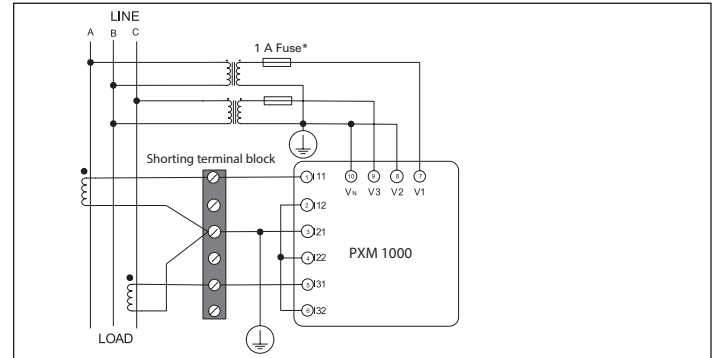

Figure 4. Three-phase, three-wire with PT and 2CT (2LL, 3CT)

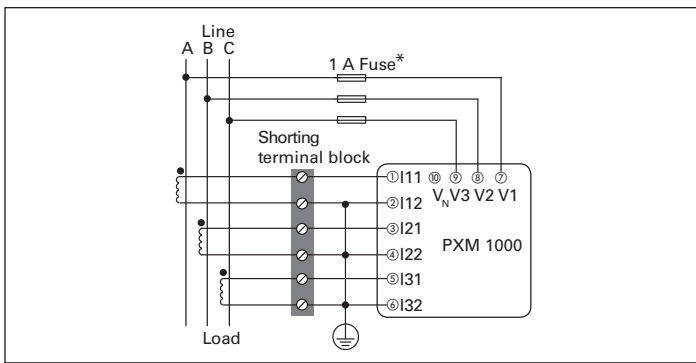

Figure 2. Three-phase, three-wire (3LL, 3CT)

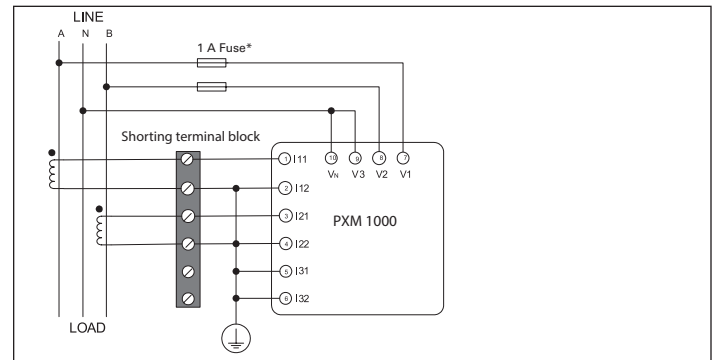

Figure 5. Single-phase, three-wire (1LL, 2CT)

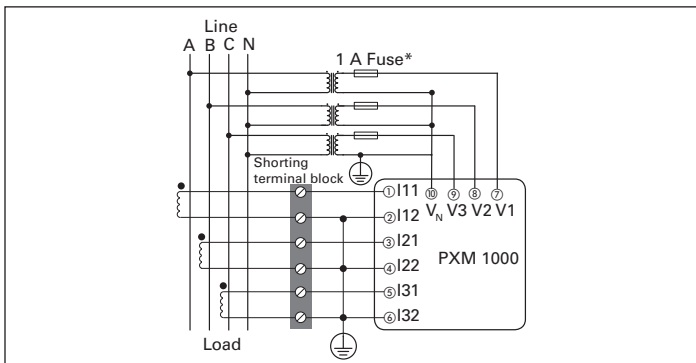

Figure 3. Three-phase, four-wire with PT (3LN, 3CT)

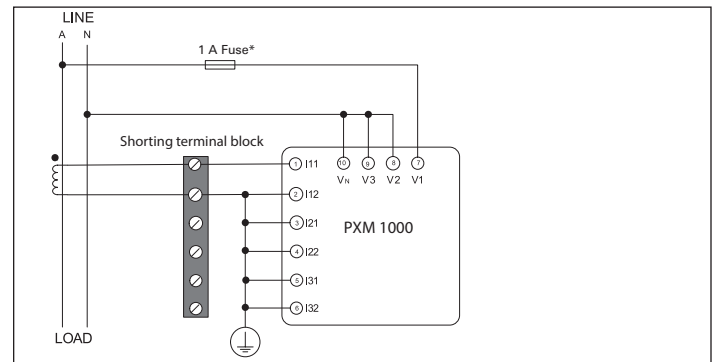

Figure 6. Single-phase, two-wire (1LN, 1CT)

\* 1A fuse typical

**Note 1:** Shorting terminal block not required when used with voltage input current sensors

**Note 2:** For meters used with voltage input current sensors, unused channels need to be tied to ground as shown in the figures. If meters are used with amperage input current sensors, then the unused channels do not need to be tied to ground.

**I/O cards wiring**

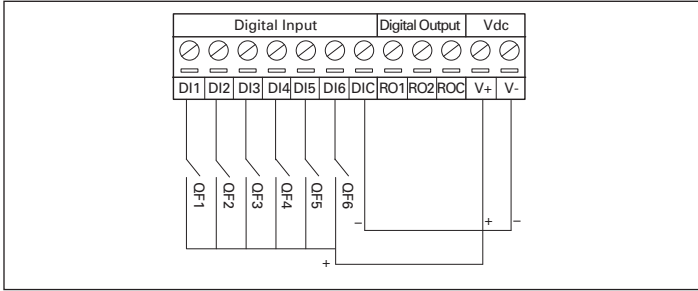

Figure 7. PXM1K-X1X

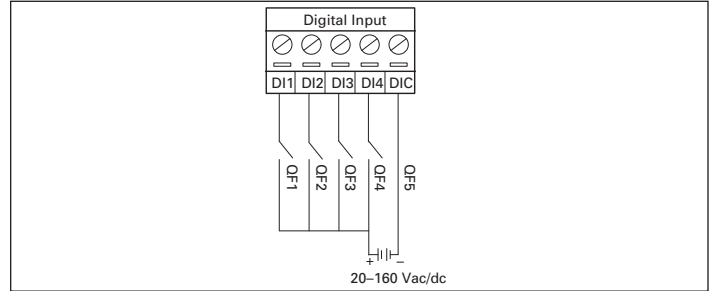

Figure 8. PXM1K-X2X/X3X

**Dimensions in inches (mm)**

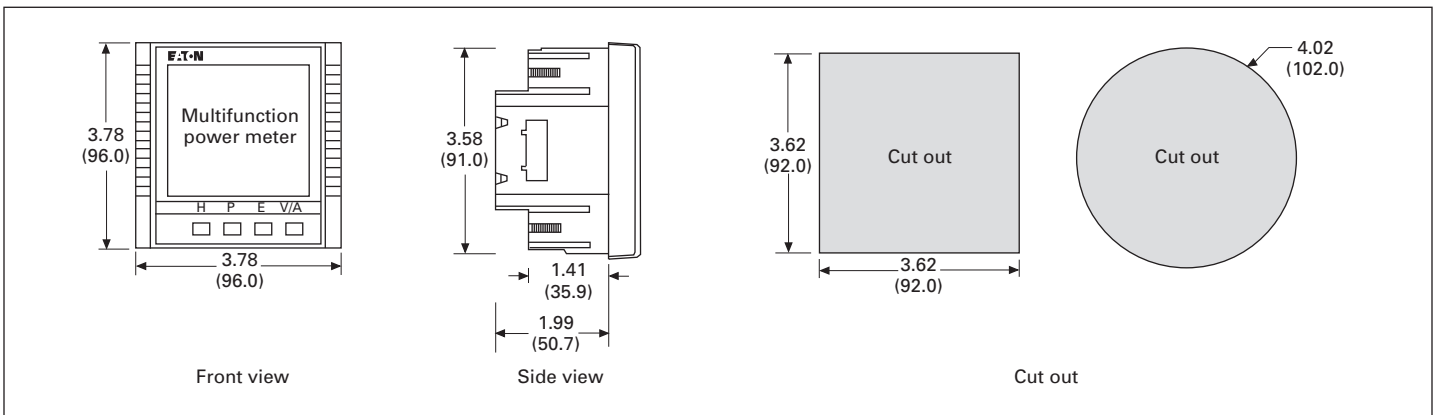

Figure 9. PXM 1000

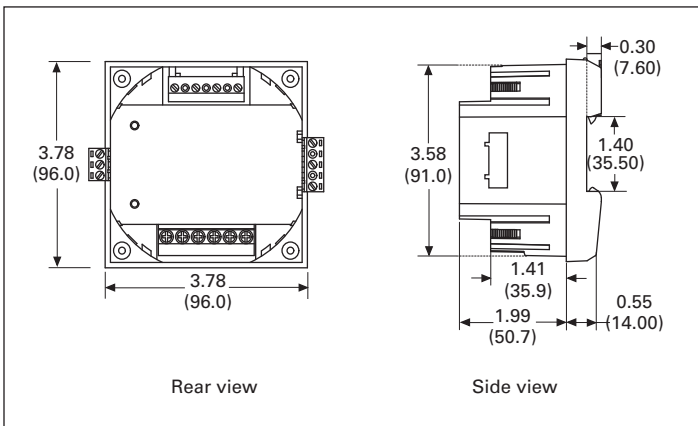

Figure 10. DIN mount meter

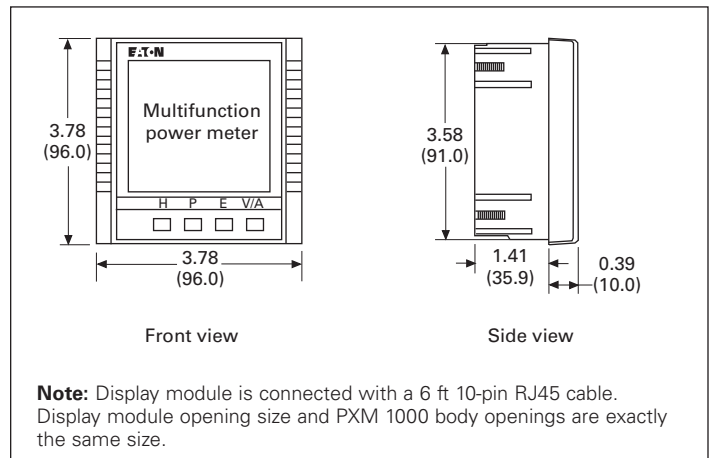

Figure 11. External display module

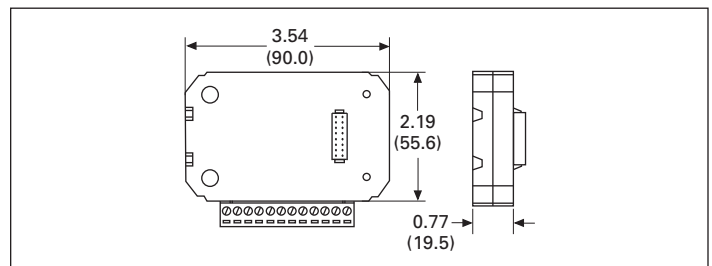

Figure 12. I/O module

### Ordering Information

To order a Power Xpert Meter 1000, the catalog number should be determined using **Table 1**. The table illustrates how to include the desired factory options as part of a catalog number. Option cards are separate and field installable.

Power Xpert Meter modules include panel mounting brackets.

**Example 1:** PXM1000MA15 (PXM 1000 meter/display, 5 A, 100–415 Vac or 100–300 Vdc)

**Example 2:** PXM1300MA13 (PXM 1300 meter/display, 333 mV, 100–415 Vac or 100–300 Vdc)

**Table 1. Power Xpert Meter 1000 catalog numbering system**

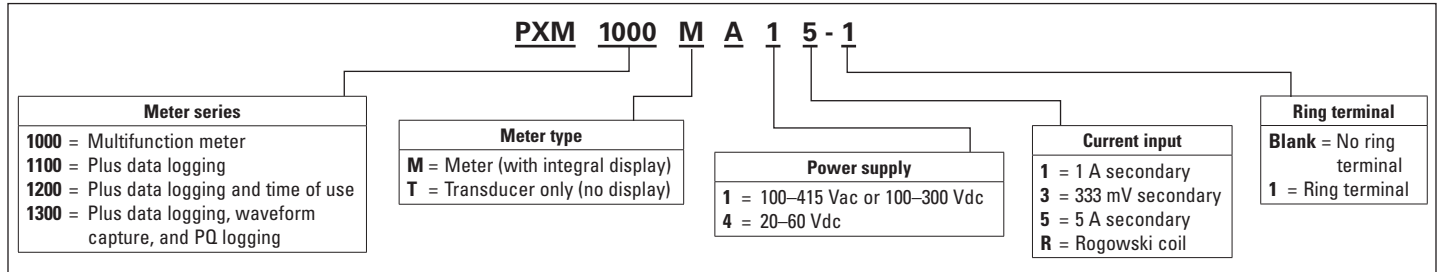

**Table 2. Power Xpert Meter 1000 I/O module**

Description	Catalog number
PXM 1000 I/O module logic address 1; 2 RO, 6DI with DI power supply 24 Vdc	<b>PXM1K-110</b>
PXM 1000 I/O module logic address 2; 2 RO, 6DI with DI power supply 24 Vdc	<b>PXM1K-120</b>
PXM 1000 I/O module logic address 1; 4 DI, 2 DO, 2 AO (4–20 mA)	<b>PXM1K-210</b>
PXM 1000 I/O module logic address 1; 4 DI, 2 DO, 2 AO (0–20 mA)	<b>PXM1K-211</b>
PXM 1000 I/O module logic address 1; 4 DI, 2 DO, 2 AO (1–5 V)	<b>PXM1K-212</b>
PXM 1000 I/O module logic address 1; 4 DI, 2 DO, 2 AO (0–5 V)	<b>PXM1K-213</b>
PXM 1000 I/O module logic address 2; 4 DI, 2 DO, 2 AO (4–20 mA)	<b>PXM1K-220</b>
PXM 1000 I/O module logic address 2; 4 DI, 2 DO, 2 AO (0–20 mA)	<b>PXM1K-221</b>
PXM 1000 I/O module logic address 2; 4 DI, 2 DO, 2 AO (1–5 V)	<b>PXM1K-222</b>
PXM 1000 I/O module logic address 2; 4 DI, 2 DO, 2 AO (0–5 V)	<b>PXM1K-223</b>
PXM 1000 I/O module logic address 1; 4 DI, 2 RO, 2 AI (4–20 mA)	<b>PXM1K-310</b>
PXM 1000 I/O module logic address 1; 4 DI, 2 RO, 2 AI (0–20 mA)	<b>PXM1K-311</b>
PXM 1000 I/O module logic address 1; 4 DI, 2 RO, 2 AI (1–5 V)	<b>PXM1K-312</b>
PXM 1000 I/O module logic address 1; 4 DI, 2 RO, 2 AI (0–5 V)	<b>PXM1K-313</b>
PXM 1000 I/O module logic address 2; 4 DI, 2 RO, 2 AI (4–20 mA)	<b>PXM1K-320</b>
PXM 1000 I/O module logic address 2; 4 DI, 2 RO, 2 AI (0–20 mA)	<b>PXM1K-321</b>
PXM 1000 I/O module logic address 2; 4 DI, 2 RO, 2 AI (1–5 V)	<b>PXM1K-322</b>
PXM 1000 I/O module logic address 2; 4 DI, 2 RO, 2 AI (0–5 V)	<b>PXM1K-323</b>

**Table 3. Power Xpert Meter 1000 accessories**

Description	Catalog number
PXM 1000 panel mount remote display for DIN rail mount transducer version; include one 6 ft cable	<b>PXM1K-DISP-3</b>

**Table 4. Power Xpert Meter 1000 communications modules**

Description	Catalog number
PXM 1000 Modbus TCP with Web/HTTP Push	<b>PXM1K-MTCPP</b>
PXM 1000 BACnet/IP and Modbus TCP with Web/HTTP Push	<b>PXM1K-BIPP</b>

**Table 5. Rogowski coils**

Description	Catalog number
PXM 1000 16-inch long Rogowski coil CT with 4-inch window calibrated for 5–1200 A	<b>CS-16-4-1000-RC</b>
PXM 1000 16-inch long Rogowski coil CT with 4-inch window calibrated for 12.5–3000 A	<b>CS-16-4-2500-RC</b>
PXM 1000 16-inch long Rogowski coil CT with 4-inch window calibrated for 25–6000 A	<b>CS-16-4-5000-RC</b>
PXM 1000 16-inch long Rogowski coil CT with 4-inch window calibrated for 50–12,000 A	<b>CS-16-4-12000-RC</b>
PXM 1000 16-inch long Rogowski coil CT with 4-inch window calibrated for 250–50,000 A	<b>CS-16-4-50000-RC</b>
PXM 1000 24-inch long Rogowski coil CT with 7-inch window calibrated for 5–1200 A	<b>CS-24-7-1000-RC</b>
PXM 1000 24-inch long Rogowski coil CT with 7-inch window calibrated for 12.5–3000 A	<b>CS-24-7-2500-RC</b>
PXM 1000 24-inch long Rogowski coil CT with 7-inch window calibrated for 25–6000 A	<b>CS-24-7-5000-RC</b>
PXM 1000 24-inch long Rogowski coil CT with 7-inch window calibrated for 50–12,000 A	<b>CS-24-7-12000-RC</b>
PXM 1000 24-inch long Rogowski coil CT with 7-inch window calibrated for 250–50,000 A	<b>CS-24-7-50000-RC</b>
PXM 1000 36-inch long Rogowski coil CT with 10-inch window calibrated for 5–1200 A	<b>CS-36-10-1000-RC</b>
PXM 1000 36-inch long Rogowski coil CT with 10-inch window calibrated for 12.5–3000 A	<b>CS-36-10-2500-RC</b>
PXM 1000 36-inch long Rogowski coil CT with 10-inch window calibrated for 25–6000 A	<b>CS-36-10-5000-RC</b>
PXM 1000 36-inch long Rogowski coil CT with 10-inch window calibrated for 50–12,000 A	<b>CS-36-10-12000-RC</b>
PXM 1000 36-inch long Rogowski coil CT with 10-inch window calibrated for 250–50,000 A	<b>CS-36-10-50000-RC</b>
PXM 1000 47-inch long Rogowski coil CT with 14-inch window calibrated for 5–1200 A	<b>CS-47-14-1000-RC</b>
PXM 1000 47-inch long Rogowski coil CT with 14-inch window calibrated for 12.5–3000 A	<b>CS-47-14-2500-RC</b>
PXM 1000 47-inch long Rogowski coil CT with 14-inch window calibrated for 25–6000 A	<b>CS-47-14-5000-RC</b>
PXM 1000 47-inch long Rogowski coil CT with 14-inch window calibrated for 50–12,000 A	<b>CS-47-14-12000-RC</b>
PXM 1000 47-inch long Rogowski coil CT with 14-inch window calibrated for 250–50,000 A	<b>CS-47-14-50000-RC</b>

## Technical information

### Input

#### Current inputs (each channel)

Nominal secondary sensor settings:

Current Sensor Input Options	5A	1A	333mV	100mV Rope CT	80mA/100mA/200mA
Nominal Configuration Selection	5A	1A	1A	1A	1A
Metering range (% of nominal)	200%	200%	120%	120%	120%
Pickup current (% of nominal)	0.1%	0.1%	0.5%	0.5%	0.5%

Withstand: 20 A rms continuous, 100 A rms for 1 second, non-recurring

Burden: 0.05 VA (typical) at 5 A rms

Accuracy: 0.2% full scale

#### Voltage inputs (each channel)

Nominal full scale: 400 Vac L-N, 690 Vac L-L (+20%)

Withstand: 1500 Vac continuous, 2500 Vac, 50/60 Hz for 1 minute

Input impedance: 2 mohm per phase

Metering frequency: 45–65 Hz, 300–500 Hz

Pickup voltage: 10 Vac

Accuracy: 0.2% full scale

#### Energy accuracy

Active: Class 0.2 s (according to IEC 62053-22), Class 0.2 s (according to ANSI C12.20)

Reactive: Class 2 (according to IEC 62053-23)

#### Harmonic resolution

Metered value: 63rd harmonic (50 Hz or 60 Hz type), 15th harmonic (400 Hz type)

### Communication

#### RS-485 (standard)

Modbus RTU and DNP 3.0

Two-wire shielded twisted pair cable connection

Baud rate: 1200–38,400 bps

#### Second RS-485 port (optional)

(The same as RS-485 standard contents)

#### Standard compliance

Measurement standard: IEC 62053-22; ANSI C12.20

Environmental standard: IEC 60068-2

Safety standard: IEC 61010-1, UL 61010-1, IEC 61557-12

EMC standard: IEC 61000-4/-2-3-4-5-6-8-11, CISPR 22, IEC 61000-3-2, IEC 61000-6-2/4

Outlines standard: DIN 43700, ANSI C39.1

#### Operating environment

Operation temperature: –25 °C to +70 °C

Storage temperature: –40 °C to +85 °C

Relative humidity: 5% to 95% noncondensing

Protection level: IP54 (front), IP30 (cover)

### I/O option

#### Digital input

Input voltage range: 20–160 Vac/Vdc

Input current (max.): 2 mA

Start voltage: 15 V

Stop voltage: 5 V

Pulse frequency (max.): 100 Hz, 50% duty ratio (5 ms ON and 5 ms OFF)

SOE resolution: 2 ms

#### Digital output (DO) (photo-MOS)

Voltage range: 0–250 Vac/Vdc

Load current: 100 mA (max.)

Output frequency: 25 Hz, 50% duty ratio (20 ms ON, 20 ms OFF)

Isolation voltage: 2500 Vac

#### Relay output (RO)

Switching voltage (max.): 250 Vac, 30 Vdc

Load current: 5 A (resistive), 2 A (inductive)

Set time: 10 ms (max.)

Contact resistance 30 mohm (max.)

Isolation voltage: 2500 Vac

Mechanical life: 1.5 x 10<sup>7</sup>

#### Analog output (AO)

Output range: 0–5 V / 1–5 V, 0–20 mA / 4–20 mA (optional)

Accuracy: 0.5%

Temperature drift: 50 ppm / °C typical

Isolation voltage: 500 Vdc

Open circuit voltage: 15 V

#### Analog input (AI)

Input range: 0–5 V / 1–5 V, 0–20 mA / 4–20 mA (optional)

Accuracy: 0.2%

Temperature drift: 50 ppm / °C typical

Isolation voltage: 500 Vdc

#### Power supply for DI (24 Vdc)

Output voltage: 24 Vdc

Output current: 42 mA

Load (max.): 21 DIs

#### Control power

Universal: AC or DC

#### AC/DC control power

Operating range: 100–415 Vac, 50/60 Hz; 100–300 Vdc

Burden: 5 W

Frequency: 50/60 Hz

Withstand: 3250 Vac, 50/60 Hz for 1 minute

Installation Category III (distribution)

#### Low voltage DC control power (optional)

Operating range: 20–60 Vdc

Burden: 5 W

**Eaton**  
1000 Eaton Boulevard  
Cleveland, OH 44122  
United States  
Eaton.com

© 2018 Eaton  
All Rights Reserved  
Printed in USA  
Publication No. TD026079EN / TBG001356  
October 2018