

Power Xpert® Meter 4000/6000/8000 Quick Start Guide



Copyright © 2017 by Eaton. All rights reserved.

Specifications and information contained herein are subject to change without notice.

Power Xpert and PowerVision are registered trademarks of Eaton.

EATON - CONFIDENTIAL AND PROPRIETARY NOTICE TO PERSONS RECEIVING THIS DOCUMENT AND/OR TECHNICAL INFORMATION

THIS DOCUMENT, INCLUDING THE DRAWING AND INFORMATION CONTAINED THEREON, IS CONFIDENTIAL AND IS THE EXCLUSIVE PROPERTY OF EATON, AND IS MERELY ON LOAN AND SUBJECT TO RECALL BY EATON AT ANY TIME. BY TAKING POSSESSION OF THIS DOCUMENT, THE RECIPIENT ACKNOWLEDGES AND AGREES THAT THIS DOCUMENT CANNOT BE USED IN ANY MANNER ADVERSE TO THE INTERESTS OF EATON, AND THAT NO PORTION OF THIS DOCUMENT MAY BE COPIED OR OTHERWISE REPRODUCED WITHOUT THE PRIOR WRITTEN CONSENT OF EATON. IN THE CASE OF CONFLICTING CONTRACTUAL PROVISIONS, THIS NOTICE SHALL GOVERN THE STATUS OF THIS DOCUMENT.

DISCLAIMER OF WARRANTIES AND LIMITATION OF LIABILITY

The information, recommendations, descriptions and safety notations in this document are based on Eaton Electrical Inc. and/or Eaton's ("Eaton") experience and judgment and may not cover all contingencies. If further information is required, an Eaton sales office should be consulted.

Sale of the product shown in this literature is subject to the terms and conditions outlined in appropriate Eaton selling policies or other contractual agreement between Eaton and the purchaser.

THERE ARE NO UNDERSTANDINGS, AGREEMENTS, WARRANTIES, EXPRESSED OR IMPLIED, INCLUDING WARRANTIES OF FITNESS FOR A PARTICULAR PURPOSE OR MERCHANTABILITY, OTHER THAN THOSE SPECIFICALLY SET OUT IN ANY EXISTING CONTRACT BETWEEN THE PARTIES. ANY SUCH CONTRACT STATES THE ENTIRE OBLIGATION OF EATON. THE CONTENTS OF THIS DOCUMENT SHALL NOT BECOME PART OF OR MODIFY ANY CONTRACT BETWEEN THE PARTIES.

In no event will Eaton be responsible to the purchaser or user in contract, in tort (including negligence), strict liability or otherwise for any special, indirect, incidental or consequential damage or loss whatsoever, including but not limited to damage or loss of use of equipment, plant or power system, cost of capital, loss of power, additional expenses in the use of existing power facilities, or claims against the purchaser or user by its customers resulting from the use of the information, recommendations and descriptions contained herein.

Table of Contents

1. Introduction.....	5
1.1. Safety Precautions.....	5
2. Quick Start Guide for the Meter.....	7
2.1. Safety Precautions	7
2.2. Power Supply Connections.....	8
2.3. Configure the Security Mode Dip Switches	9
2.4. Com Reset Switch.....	10
2.5. Base Address	10
2.6. VT , VX, and CT Connections	10
2.7. Establishing Communications between the Meter and the Displays	11
2.8. Connecting to a Meter Using the Embedded Web Server Interface	12
2.9. Programming the Meter via the Optional Communications Expansion Card.....	13
3. Mounting and Wiring	17
3.1. Mounting the Meter and Displays	17
3.2. General Instructions	17
3.3. Wiring	18
3.4. Fuses	21
3.5. Hipot and Megohm (Megger) Testing.....	21
3.6. Communication Wiring	21
3.7. RS485 Network	22
3.8. RS485 Cable Characteristics	22
3.9. RS485 Wiring Basics	22
4. Ratings	25
4.1. Environmental Ratings	25
4.2. PowerXpert I/O Board (PXMIO Card).....	25
4.3. Electrical Ratings	25
4.4. Meter and Display Cleaning instructions	26

1. Introduction

1.1. Safety Precautions

All safety codes, safety standards and/or regulations must be strictly observed in the installation, operation and maintenance of this device.



WARNINGS refer to a hazardous situation which, if not avoided, could result in death or serious injury.



CAUTIONS refer to a hazardous situation which, if not avoided, could result in equipment damage.

WARNINGS

SHOCK HAZARDS:

IMPROPER INSTALLATION CAN CAUSE DEATH, INJURY AND/OR EQUIPMENT DAMAGE. Follow all Warnings and Cautions. Completely read and understand the information in this document before attempting to install or operate the equipment. Improper wiring could cause death, injury and/or equipment damage. Only qualified personnel are to service the Power Xpert® Meter.

TROUBLESHOOTING PROCEDURES MAY REQUIRE PROXIMITY TO EXPOSED ENERGIZED (LIVE) ELECTRICAL WIRING AND/OR PARTS WHERE THE HAZARD OF FATAL ELECTRIC SHOCK IS PRESENT.

Exercise extreme care to avoid injury or death. Always disconnect, lock-out and tag the current and voltage sources and the control power supply circuit before touching the connections or components on the rear face of the meter.

FAILURE TO GROUND THE POWER XPERT® METER MAY RESULT IN INJURY, DEATH OR EQUIPMENT DAMAGE.

Properly ground the Power Xpert® Meter during installation.

2. Quick Start Guide for the Meter

2.1. Safety Precautions

All safety codes, safety standards and/or regulations must be strictly observed in the installation, operation and maintenance of this device.

 **WARNINGS** refer to instructions that, if not followed, can result in death or injury.

 **CAUTIONS** refer to instructions that, if not followed, can result in equipment damage.

 **WARNINGS**

SHOCK HAZARDS:

IMPROPER INSTALLATION CAN CAUSE DEATH, INJURY AND/OR EQUIPMENT DAMAGE. Follow all Warnings and Cautions. Completely read and understand the information in this document before attempting to install or operate the equipment. Improper wiring could cause death, injury and/or equipment damage. Only qualified personnel are to service the Power Xpert Meter 4000/6000/8000 and displays.

TROUBLESHOOTING PROCEDURES MAY REQUIRE PROXIMITY TO EXPOSED ENERGIZED (LIVE) ELECTRICAL WIRING AND/OR PARTS WHERE THE HAZARD OF FATAL ELECTRIC SHOCK IS PRESENT. Exercise extreme care to avoid injury or death. Always disconnect, lock-out, and tag the current and voltage sources and the control power supply circuit before touching the connections or components on the rear face of the Power Xpert Meter 4000/6000/8000 and displays.

FAILURE TO GROUND THE POWER XPERT METER MAY RESULT IN DEATH, INJURY OR EQUIPMENT DAMAGE. Properly ground the Meter during installation.

IMPROPER ASSEMBLY AND INSTALLATION OF THE CT TERMINAL BLOCK AND STRAIN RELIEF HOOD MAY RESULT IN OPEN CIRCUITED CTS AND EXPOSURE TO DANGEROUS VOLTAGES WHICH MAY RESULT IN SEVERE INJURY OR DEATH.

Terminal block hoods are provided with the metering current and voltage terminal blocks. The current terminal block retaining screws are part of the matching hood assembly. The current terminal block and hood assembly must be properly installed with retaining screws to secure the current terminal block to the meter housing to prevent exposure to shock hazard.

2.2. Power Supply Connections

1. Connect the Power Supply (PXMP5-1)

The Meter is powered using a 100-240 Vac or 110-250 Vdc (PXMP5-1) standard power supply.

- PS1-3 connected to ground
- PS1-2 connected to Neutral (Vac) or (-) Vdc
- PS1-1 connected to Line (Vac) or (+) Vdc

Fabricate a power cord of suitable length to connect PS1-1/PS1-2/PS1-3 (refer to Figure 1) to a suitable Power Source that supplies (100-240 Vac or 110-250 Vdc).

- Power LED should be solid blue ON.
- Health LED should blink green once per second.
- Status LED will blink red if there are unacknowledged events.

Refer to Troubleshooting Section in this manual.

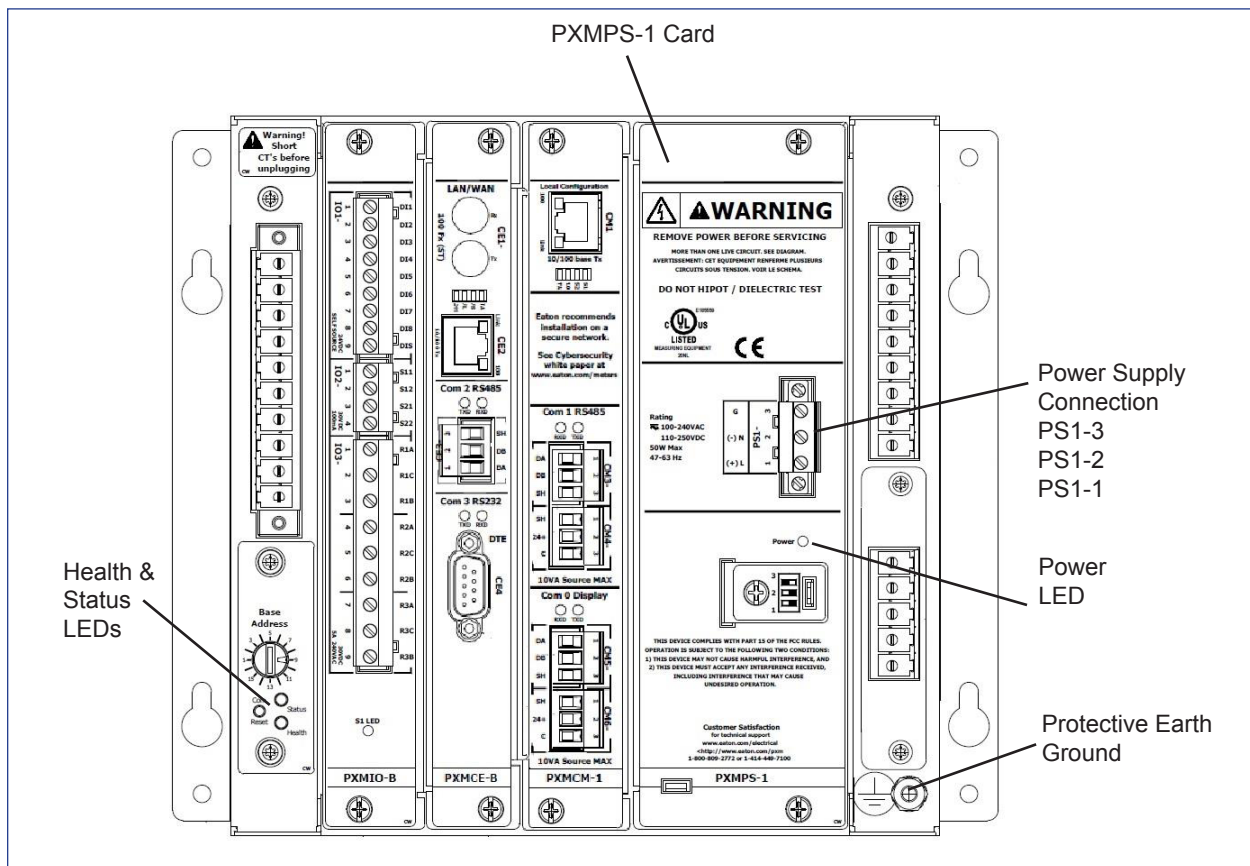



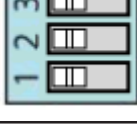

Figure 1: Meter Power Supply Connection and LED Locations.

2.3. Configure the Security Mode Dip Switches

DS-1	DS-2	DS-3		
OFF	OFF	ON is Normal. OFF is Safe Mode.	No restrictions (user ID/Password required) ADMIN/ADMIN accepted for 15 minutes after boot-up	
OFF	ON	ON is Normal. OFF is Safe Mode.	Medium Security - Energy & Demand resets prohibited	
ON	OFF	ON is Normal. OFF is Safe Mode.	High Security- Configuration changes; Energy & Demand reset prohibited	
ON	ON	ON or OFF.	Factory Test Mode - The meter should never be operated in this mode. The meter will indicate that it's in factory test mode through a repeating series of three flashes on the red Status LED	

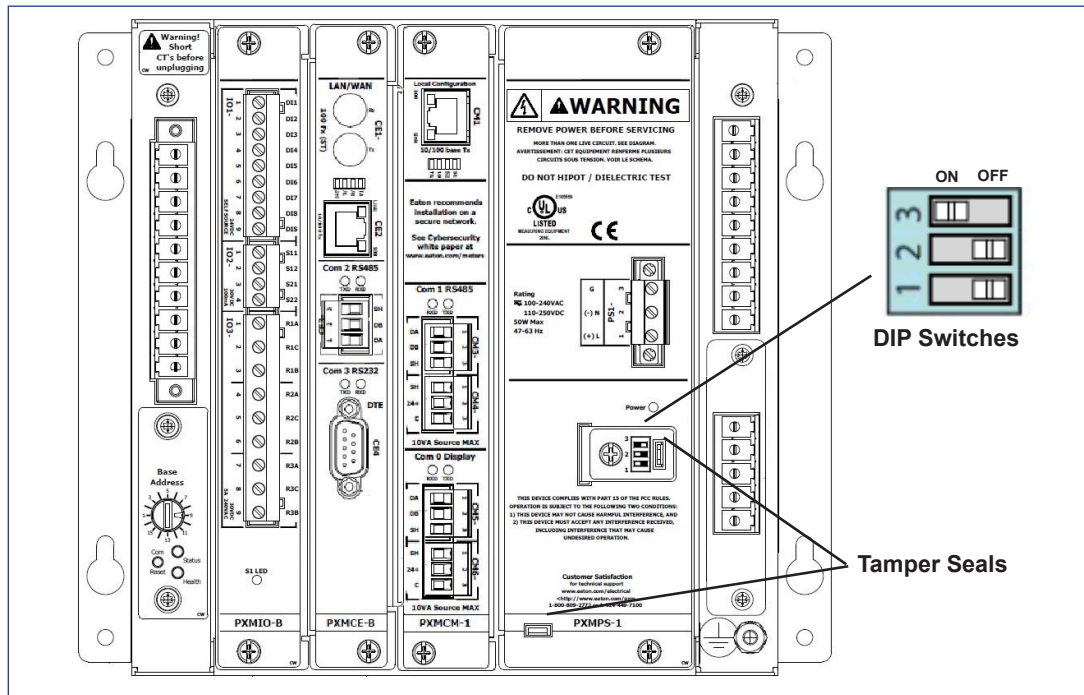
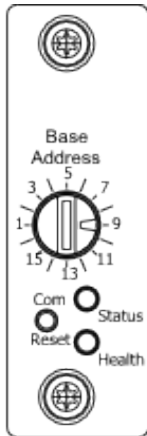

Figure 2: Meter's Dip Switches and Tamper Seals.

2.4. Com Reset Switch



Located above the rotary switch, the Com Reset switch can be used in conjunction with the DIP switches on the power supply front panel to reset the meter's communications ports. The reset switch has the following functions, depending on the DIP switch settings.

DS -1	DS-2	DS-3		
OFF	OFF	ON	Initialize all communications ports to their factory default settings.	
OFF	ON	ON	Initialize the LAN/WAN and Local Config communications ports and assign the following IP addresses: LAN/WAN: 10.1.1.1 Local Config: 192.168.1.1	
ON	OFF	ON	Attempt to recover communications via the LAN/WAN port by disabling then re-enabling the communications port.	
ON	ON	ON or OFF	Factory Test Mode - The meter should never be operated in this mode. The meter will indicate that it's in factory test mode through a repeating series of three flashes on the red Status LED.	

Refer to the User and Installation Manual (IM02601004E) for more information.

2.5. Base Address

The Power Xpert Meter has a rotary Base Address switch on the bottom-left side of the meter. This rotary switch is for use with the obsolete PXD-MMG on COM0 and does not apply to COM1, COM2, or COM3.

2.6. VT , VX, and CT Connections

Planning CT and VT Connections (Figure 3)

Determine your wiring requirements for the meter. This quick start guide will cover these basic wiring configurations:

- 3-Phase, 3-Wire Delta(Up to 600 V L-L, 347 L-N) 3 CTs
- 3-Phase, 3-Wire Delta (Above Up to 600 V L-L, 347 L-N) 3 CTs
- 3-Phase, 3-Wire Delta (Above Up to 600 V L-L, 347 L-N) 2 CTs
- 3-Phase,4-Wire Y (Up to Up to 600 V L-L, 347 L-N)
- 3-Phase,4-Wire Y (Above Up to 600 V L-L, 347 L-N)

See Wiring Diagrams in this manual for examples of CT and PT connections.

VT Terminal Voltage Connections:

Voltage Inputs can accept up to 600 Vac L:L / 347VL:G direct. A PT with a 120 V secondary is required if this rating is exceeded. Primary settings are 120-500,000, for a PT ratio of 120:120 to 500000 to 120. It is strongly recommended that the Voltage Inputs be connected to the Meter by way of properly rated disconnect switches.

- VTV1 = Line 1 or Va
- VTV2 = Line 2 or Vb
- VTV3 = Line 3 or Vc
- VTV4 = Line 4 or Vn (neutral)
- VTVR = Metering Reference Ground

VX Optional Auxiliary Voltage Connections:

- VXV6 = Line 1' or Va2
- VXV7 = Line 2' or Vb2
- VXV8 = Line 3' or Vc2

CT Terminal Connections:

Current Inputs accepts a 5-amp secondary with available Primary settings of 5-9999, for a CT ratio of 5:5 to 9999:5. It is strongly recommended that the Current Inputs be connected to the Meter by way of a shorting block.

- Line 1 CT connected to Terminals 11 (polarity mark) & 12 (return)
- Line 2 CT connected to Terminals 21 (polarity mark) & 22 (return)
- Line 3 CT connected to Terminals 31 (polarity mark) & 32 (return)
- Neutral CT connected to Terminals 41 (polarity mark) & 42 (return)
- Ground CT connected to Terminals 51 (polarity mark) & 52 (return)

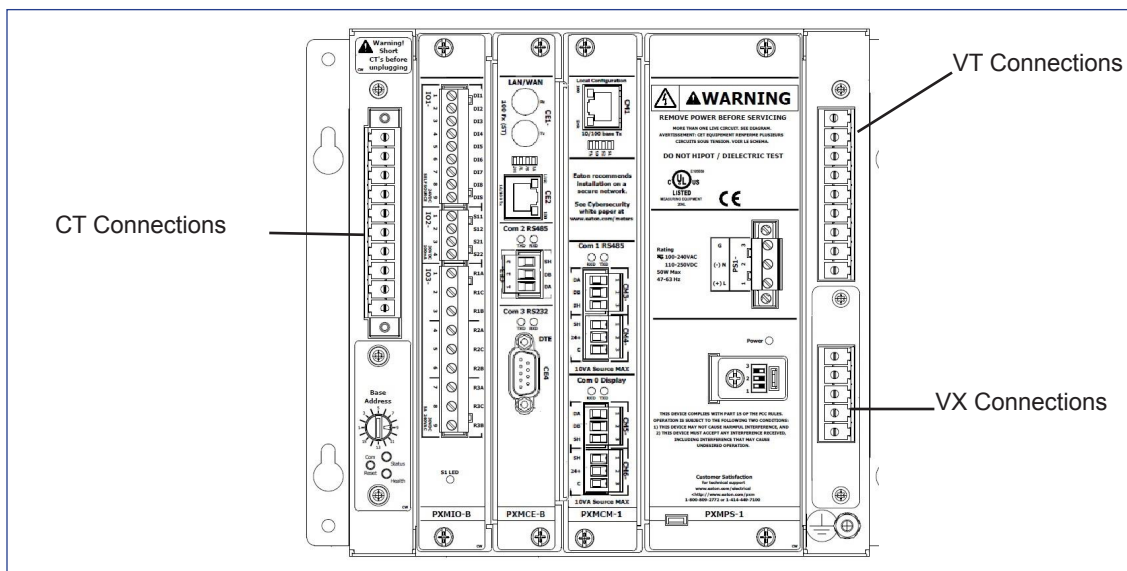

Figure 3: CT and VT Connections.

2.7. Establishing Communications between the Meter and the Displays

1. 6-inch color touchscreen display: See TD150015EN (available on the Eaton website, www.eaton.com/meters) for instructions on how to connect the 6-inch display to the Meter.
2. 12-inch advanced color touchscreen display: See TD150019EN (available on the Eaton website, www.eaton.com/meters) for instructions on how to connect the 12-inch display to the Meter.

2.8. Connecting to a Meter Using the Embedded Web Server Interface

NOTE: The set up of the Ethernet ports on the CE card must be done through the local configuration port of the CM card or with the display. After the CE Ethernet port is configured, the meter can be programmed remotely through the LAN/WAN connection.

1. Connecting a laptop to the meter using the local Ethernet browser interface CM1:

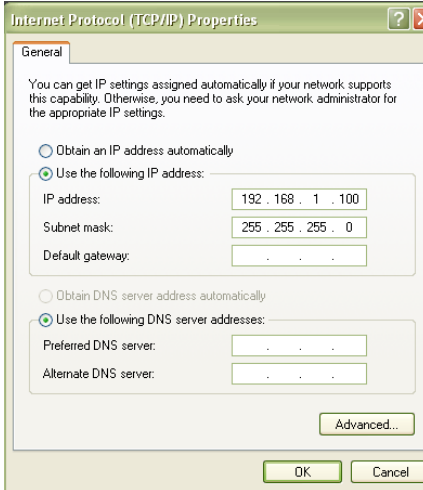

- A. Connect the Laptop to the Meter via CM1 port (see Figure 4 below) using a UTP **Cat5 Patch Cable**. Note that the IP address of the CM1 port is configured to be 192.168.1.1.
- B. Set the laptop's IP address to 192.168.1.100 by completing the following steps:
 - Click Window's Start. Then click Settings. Navigate to the Control Panel of your computer.
 - In Control Panel, click Network and right-click Local PC Area Connection. Select Properties from the shortcut menu.
 - In the Properties dialog, select Internet Protocol (TCP/IP) and click the Properties button.
 - In the Internet Protocol (TCP/IP) Properties window, select "Use the following IP address" and then enter the following IP address 192.168.1.100, with a Subnet Mask set to 255.255.255.0.
 - Click OK.

Launch a web browser and then navigate to <http://192.168.1.1>, then go to Step 2 in Section 2.9.

NOTES: When connected to a laptop, the Link LED will illuminate and, when communicating, the TXRX LED will flicker.

For PXC Cards, the local configuration port may require the use of a UTP Cat 5 cross over cable. The PXMCM card accepts a standard Cat 5 patch cable.

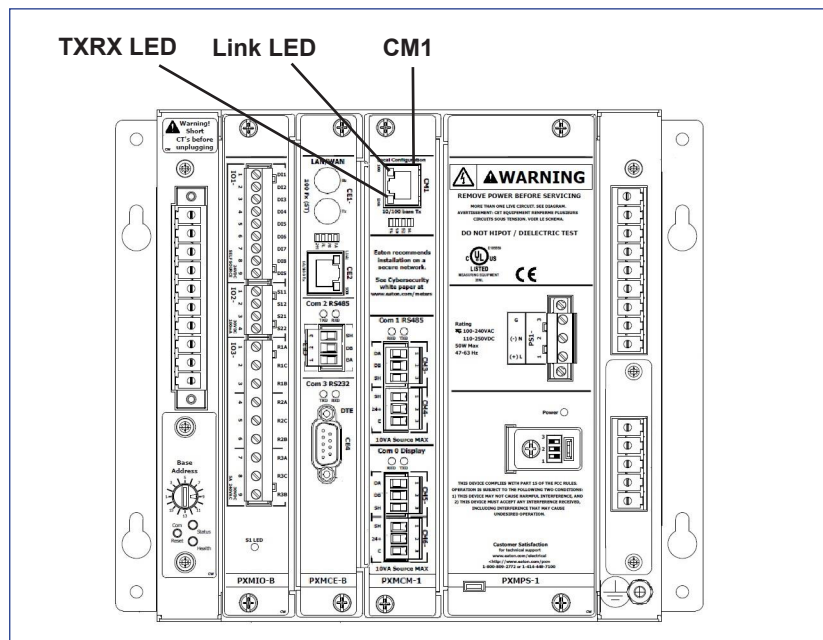

Figure 4: Connect Laptop to Meter.

2.9. Programming the Meter via the Optional Communications Expansion Card

The Optional Communications Expansion (CE) card (see Figure 5 below) provides LAN/WAN Web Ethernet communication via either Fiber (CE1) or UTP/STP Cat5 cable (CE2). It also provides communication via Modbus RTU (CE3 & CE4 - see Appendix A of the manual for Modbus instructions).

Note: The CE card is generally installed by the factory at time of manufacture. If the card is installed as an after sale option, follow instructions for physical installation that accompany the card or refer to the User and Installation Manual (IM02601004E). To set up the card, follow these steps:

- A. The PXMCE ships with CE2 enabled for DHCP. Once connected to the Local Area Network supporting DHCP, an IP will be assigned (this may require a power cycle to the PXM4/6/8K). Once energized, the PXMCE CE1/CE2 port LED “DH” will be illuminated. The assigned IP address for PXMCE CE1/CE2 can be determined either through an attached display (PXM468K-DISP-12 or legacy PXD-MMG) or by using the CM1 “Local Configuration” web server interface.
- B. If the PXM4/6/8k was ordered without the PXMCE and is now being installed, follow the instructions that accompany the PXMCE or refer to Power Xpert PXM 4000/6000/8000 User and Installation Manual IM02601004E.
- C. The PXMCE CE1/CE2 Ethernet settings can be modified by accessing the PXM4/6/8k CM1 “Local Configuration” web server interface. This will be required if DHCP will not be used.
- D. Power cycle the PXM4/6/8k to initiate DHCP.

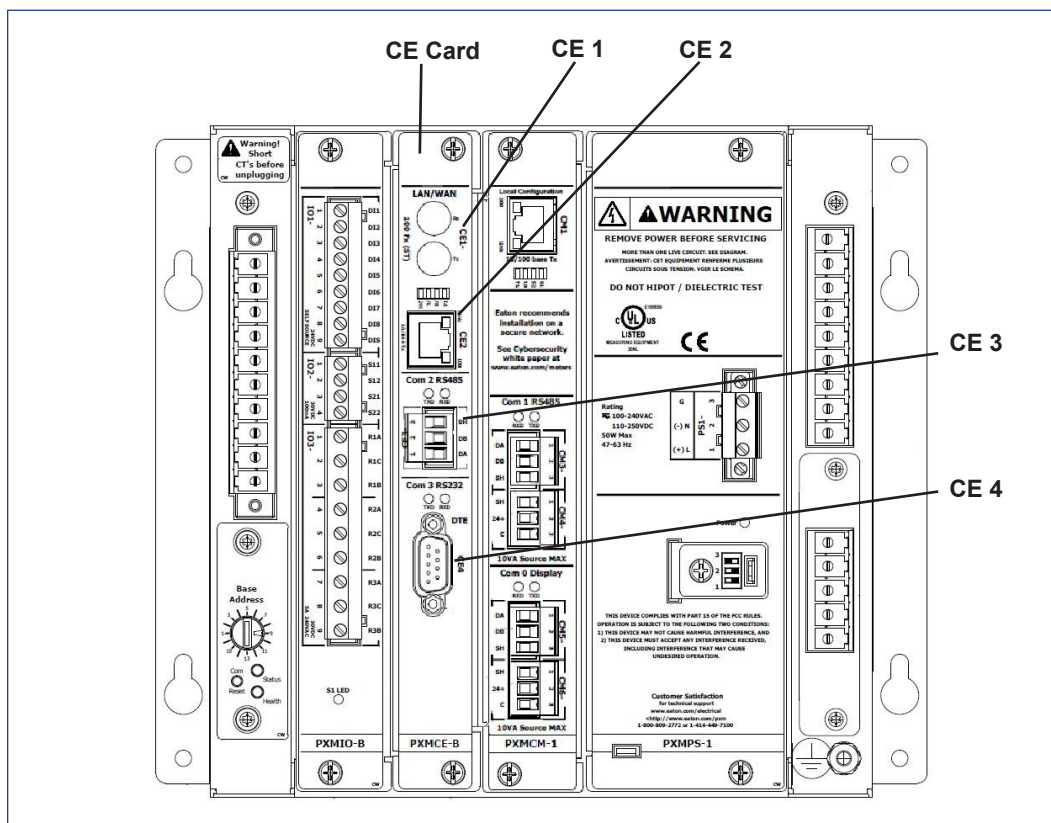
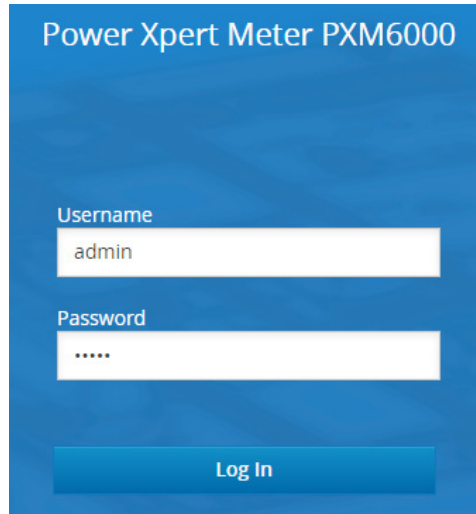

Figure 5: Ethernet and Modbus Connections.

For further details about the following steps, refer to Meter Settings using the Web Server, in the User and Installation Manual (IM02601004E).

1. Open a web browser. After “http:\\”, type in the IP address of the CE Ethernet port in the address box and click OK. The Meter Webserver Home Page will be displayed. (If DHCP is enabled, the user must find the IP address via the Local Configuration port [Setup->Diagnostics->Communication->Ethernet Status] or Local Display).
2. Enter the Username and Password. The defaults are: Username = admin and Password = admin. After entering the Username and Password, click Log In. After clicking Log In, you will be asked to change the admin password.



3. On the Meter Webserver home page, click Settings, then Quick Setup to display basic configuration setup.

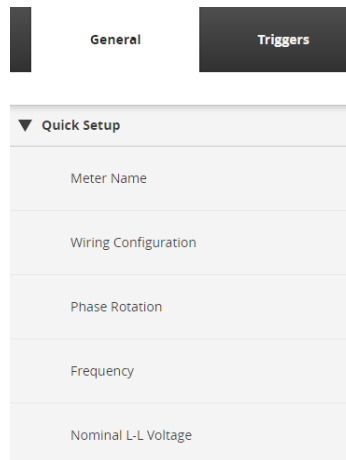

4. Click Edit to make changes to these parameters.

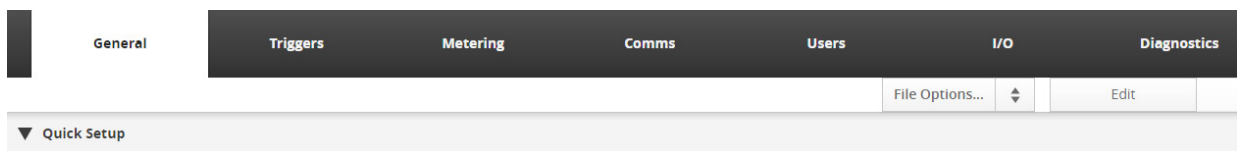

5. Set the clock by clicking on Settings > Clock > Edit.

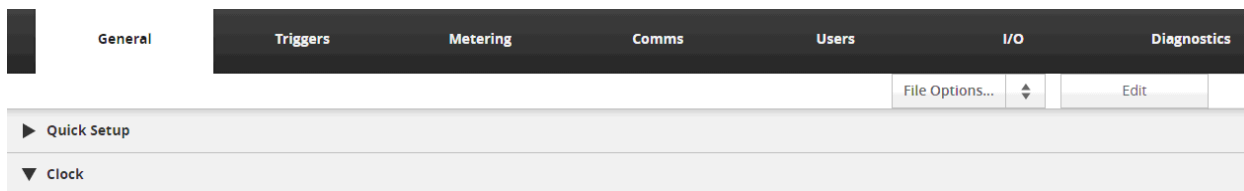

Notes on Modbus support:

The Optional Communications Expansion (CE) card also provides communication via Modbus RTU (CE3 & CE4 - see the User and Installation manual [IM02601004E] for Modbus instructions). The RS485 CE3 port supports Modbus RTU slave to a master monitoring system. The port defaults as a Master Gateway, which relays Ethernet Modbus TCP command to slave meters connected to the same RS485 link. The Modbus slave address may be set via the Display or with a web browser.

3. Mounting and Wiring



SHOCK HAZARD: VERIFY THAT ANY INCOMING AC POWER OR FOREIGN POWER SOURCES ARE TURNED OFF AND LOCKED OUT BEFORE PERFORMING ANY WORK ON THE POWER XPert 4000/6000/8000 METER OR ASSOCIATED EQUIPMENT. FAILURE TO DO SO CAN RESULT IN INJURY TO PERSONNEL OR DAMAGE TO EQUIPMENT.

The Power Xpert Meter 4000/6000/8000 is designed to be installed, operated and maintained by adequately trained personnel. These instructions do not include all details, variations or combinations of the equipment, its storage, delivery, installation, checkout, safe operation or maintenance. Compliance with local, state and national regulations, as well as with industry standard safety practices for this class of equipment, is imperative. This section describes mounting, wiring, startup and miscellaneous details associated with the Power Xpert Meter 4000/6000/8000. Every section should be reviewed prior to installing this device.

3.1. Mounting the Meter and Displays

1. To mount the Meter directly to a flat panel, as recommended, a panel cutout is not necessary. There are eight hole locations on the Meter Mounting Brackets; four circular holes and four keyholes. Use either set for mounting. See the Meter figure on page 18 for the hole sizes and locations.
2. To mount the 6-inch color touchscreen display, see TD150015EN (available on the Eaton website, www.eaton.com/meters).
3. To mount the 12-inch advanced color touchscreen display, see TD150019EN (available on the Eaton website, www.eaton.com/meters).
4. To mount the 6-inch display and the Meter back-to-back, see IL150006EN (available on the Eaton website, www.eaton.com/meters) for information on the Back to Back Meter to Display Projection Mount Adapter Kit.

Note: Only the 6-inch display can be mounted back-to-back with the meter, the 12-inch display must be mounted separately.

3.2. General Instructions

It is recommended that the Power Xpert 4000/6000/8000 Meter be mounted in an electrical switchgear enclosure that is suitable for its environment. The Power Xpert Display and Meters are generally mounted separately (see manual for mounting together). While it is recommended that the Display be door or panel mounted, the Meter can be mounted remotely from the Display on a flat surface or panel elsewhere in the enclosure.

- The Meter must remain vertical at all times to maintain proper ventilation.
- The Display and Meter may be installed in a Pollution Degree II environment.
- If the Meter is mounted remotely, the Display **MUST** be connected to earth ground.
- The Meter should be protected from accidental contact with live terminals in the enclosure. A 1/8 inch steel panel or door, solidly grounded, is recommended.
- The Meter comes standard with the remote mounting brackets attached.
- The Display comes standard with the required hardware for mounting the unit to a door or panel.

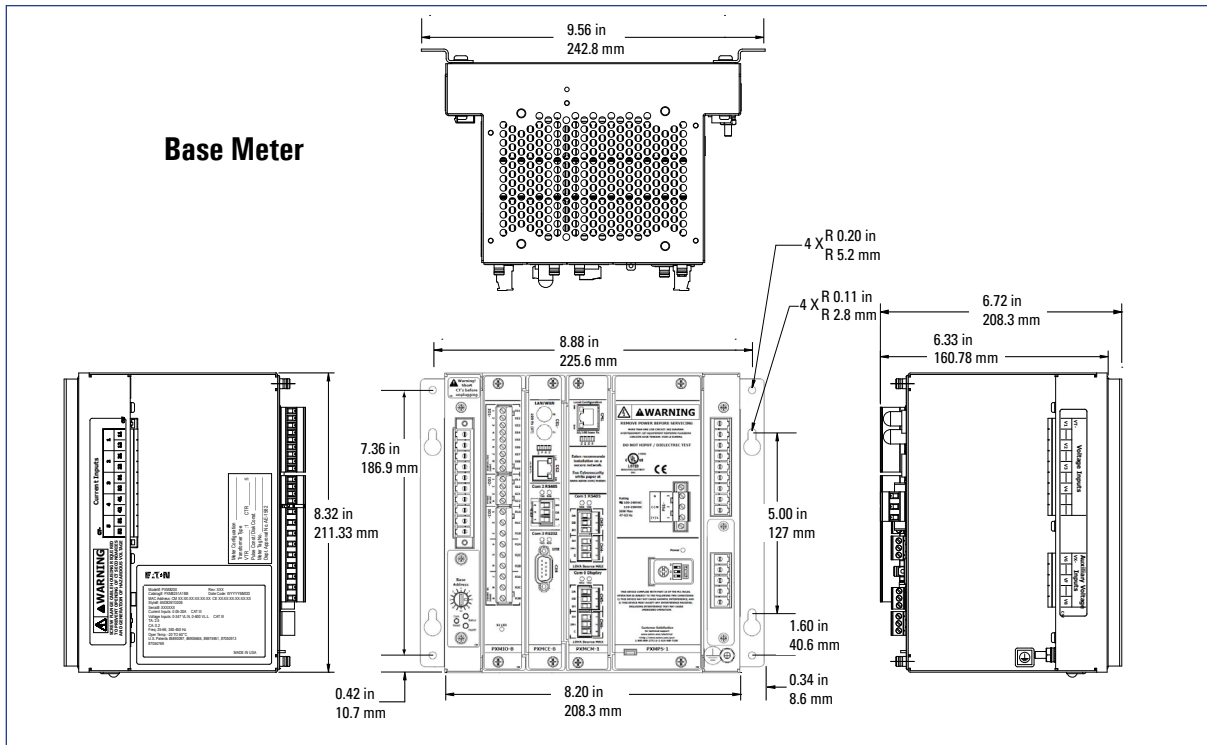

Figure 6: Power Xpert 4000/6000/8000 Meter.

3.3. Wiring

Wiring of the Power Xpert® Meter must follow a suitable wiring plan drawing. The phase wiring plan refers to the drawings made for the specific application. It describes all electrical connections between the meter and external equipment. A network wiring diagram can also be helpful for networked systems. Specific wiring diagrams are useful when creating the overall wiring plan drawing. Wiring diagrams for each system configuration are addressed below.

WARNINGS

SHOCK HAZARDS:

IF THIS DEVICE IS BEING USED ON A SINGLE PHASE SYSTEM, WIRE TO PHASE A AND NEUTRAL.

The following general considerations should be complied with during the wiring of the Power Xpert® Meter.

- All wiring must conform to applicable Federal, State and Local codes.
- The wires to the terminal blocks must not be larger than AWG No. 10 (CT, VT, VX). Larger wire will not connect properly to the terminal block.
- Wiring diagrams contacts are shown in their de-energized position.

Because the Power Xpert® Meter monitors the neutral-to-ground voltage, the chassis of the meter must be connected to ground. A good low impedance ground is essential for proper functioning.

PT AND CT SECONDARY CIRCUITS ARE CAPABLE OF GENERATING DANGEROUS VOLTAGES AND CURRENTS WITH THEIR PRIMARY CIRCUITS ENERGIZED, AND COULD CAUSE PERSONAL INJURY AND OR DEATH.

The proper selection of any required current transformers or potential transformers is critical to the proper and accurate functioning of the Power Xpert® Meter. Instrumentation grade devices are required. **Shorting blocks for CTs and a three-phase switch or circuit breaker for voltage are recommended near the equipment for ease of installation.** If assistance with the selection process is desired, contact Power Quality Technical Support representative.

Wiring Diagrams

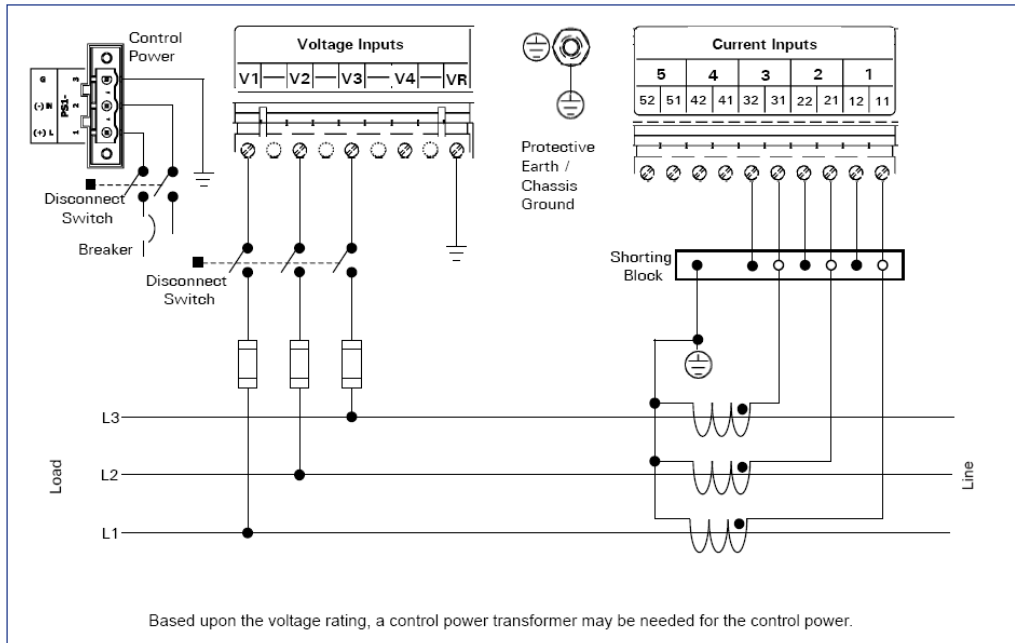

Figure 7: 3-Phase 3-Wire Delta (Up to 480 Volts). Direct Voltage and External Current Transformers.

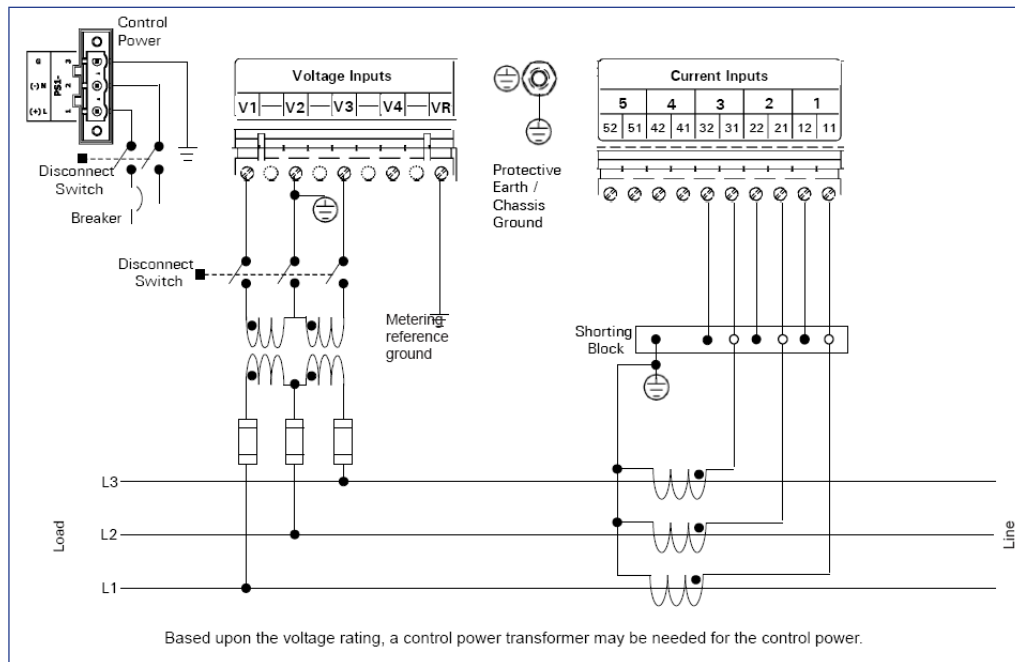

Figure 8: 3-Phase 3-Wire Delta (Up to 480 Volts). External Voltage and External Current Transformers.

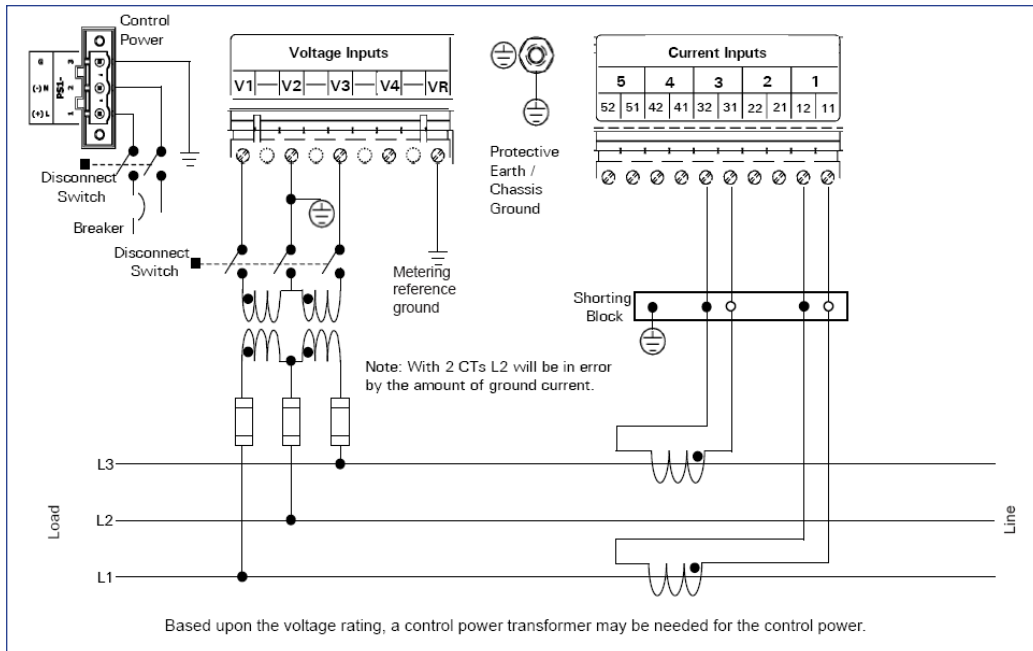

Figure 9: 3-Phase 3-Wire Delta (Up to 480 Volts) 2 CTs. External Voltage and External Current Transformers.

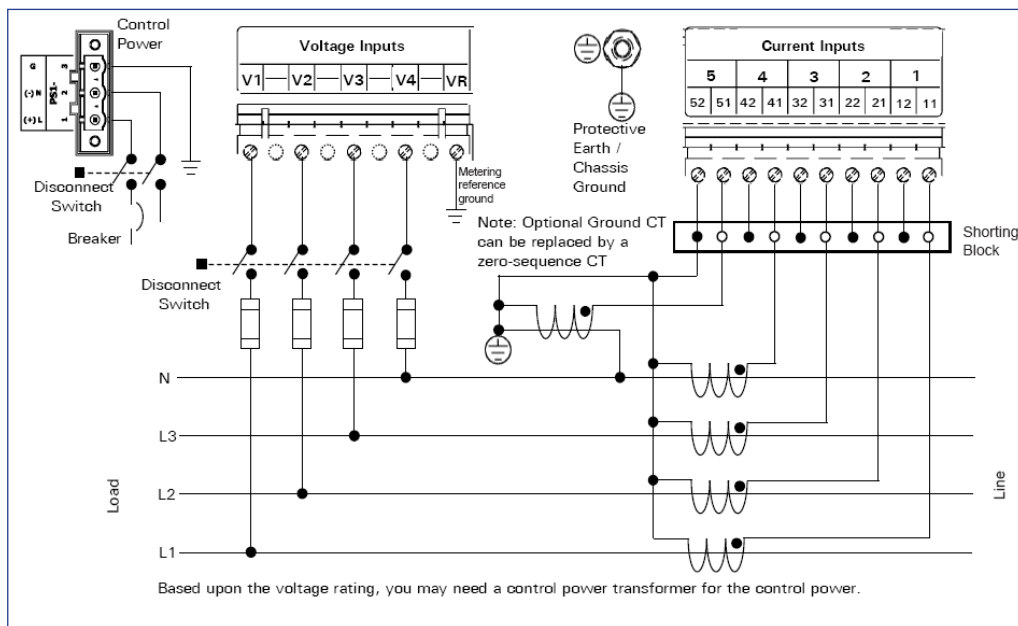

Figure 10: 3-Phase 4-Wire Y (Up to 600 Volts). Direct Voltage and External Current Transformers.

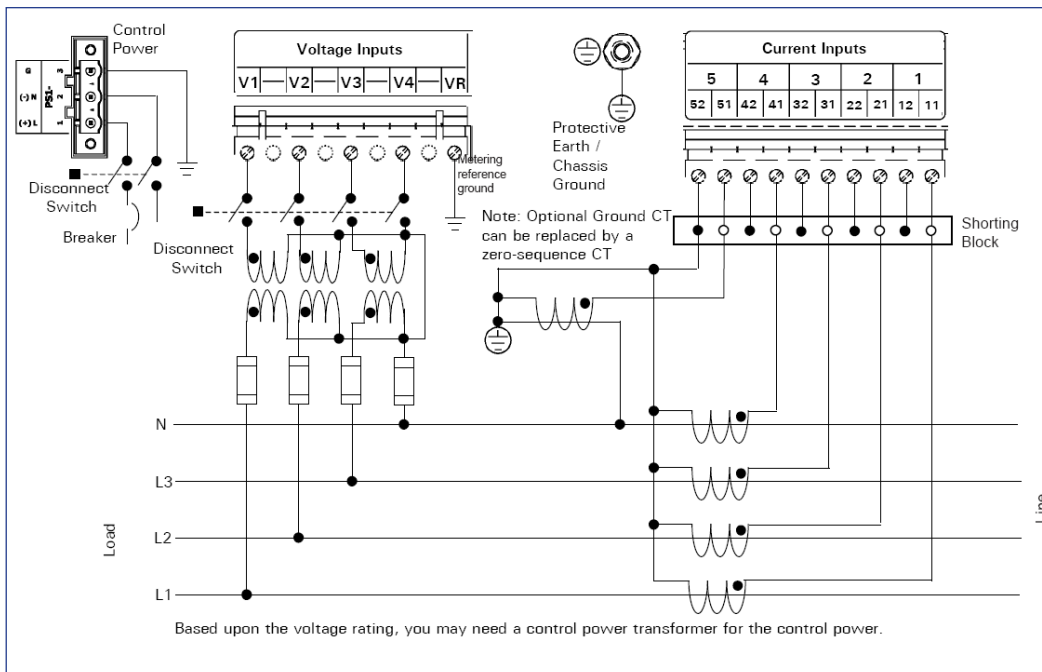

Figure 11: 3-Phase 4-Wire Y (Above 600 Volts). External Voltage Transformers and Current Transformers.

3.4. Fuses

It is required that user supplied fuses be installed as described below.

External fuses should be installed in the meter voltage tap to the main lines, near the meter housing. 600 V 1/2 A BUSS type KTK-R-1/2 Fast Acting or equivalent fuses are recommended for the Power Xpert® Meter VT connections.

External fuses should be installed in the potential transformer lines as specified in the National Electric Code (NEC) for the specific application.

The power supply wiring should be fused or put on a breaker sized to protect the wire.

3.5. Hipot and Megohm (Megger) Testing



DO NOT HIPOT OR MEGOHM TEST THE METER. SEVERE DAMAGE TO THE METER CAN RESULT.

3.6. Communication Wiring

The Power Xpert® Meter (PXM 4000/6000/8000) has inverted terminal blocks for CM4 - the 24V Auxiliary I/O Power and CM6. These inverted terminal blocks prevent the user from crossing 24v source and communication terminals.

RS485 fail safe biasing resistors are used at each master port.

Eaton strongly recommends using ferrules when connecting to a terminal block.

When connecting to a terminal block, the twisted pair sensitivity is critical for COM0, COM1, and COM2. This means that the Data A wire must match up with terminal DA (-) and the Data B wire must match up with terminal DB (+). See section 3.9 for further explanation.

3.7. RS485 Network

The following simplified rules apply to a given system consisting of master and slave devices. For more complex configurations, please refer to standard wiring specification rules for the RS485 network.

The maximum system capacity is 4,000 ft. (1219.20 m) of communication cable and 32 devices.

Make sure the twisted pair wire is recommended for RS485 network use. For reference, review the RS485 wiring spec for wiring specifications.

Tie the communication cable shield to ground only once at the RS485 master device.

Table 1. Cable Specifications.

Terminal	Port Name	Port Type	Port Connection	Cable Length	Cable Type	Max Baud Rate	Max Number of Devices	End of Line Termination	Star	Tap	Twisted Pair Sensitivity
CM5	COM0RS485	RS485	Terminal Plug	2,000 ft / 610 m	Shielded Twisted-Pair	115 K	16	120 ohms	NO	NO	YES
CM3	COM1RS485	RS485	Terminal Plug	**4,000 ft / 1,219.20 m	Shielded Twisted-Pair	115 K	32	120 ohms	NO	NO	YES
CE3	COM2RS485	RS485	Terminal Plug	**4,000 ft / 1,219.20 m	Shielded Twisted-Pair	115 K	32	120 ohms	NO	NO	YES
CE4	COM3RS232	RS232	DB9	50 ft / 15 m	Shielded Cable	115 K	2(1:1)	na	NO	NO	YES
CE1	LAN/WAN	100Fx	ST	1312.33 ft / 400 m	Multimode 62.5 m	100 M	2(1:1)	na	NO	NO	NO
CE2	LAN/WAN	10/100 T	RJ45	328 - 492 ft / 100-150 m	CAT5 Shielded Twisted Pair / UTP*	100 M	2(1:1)	na	NO	NO	NO
CM1	Local Configuration	10/100 T	RJ45	98 ft / 30 m	CAT5 Shielded Twisted Pair / UTP	100 M	2(1:1)	na	NO	NO	NO

**RS485 maximum cable length is dictated by baud rate. Above 38.4 K baud, the length is restricted to 2,000 ft (609.6 m).

3.8. RS485 Cable Characteristics

Make sure the twisted pair wire is recommended for RS485 applications:

- Single twisted pair for data 18-24 AWG
- Shield consisting of aluminized Mylar & partial coverage braid with drain wire
- Characteristic impedance ~ 120 ohms
- Data L-L capacitance ~12pf/Ft.
- Typical ratings are 75C and 300V NEC CM
- Belden Data Tray series 3074F is 600 V NEC TC

3.9. RS485 Wiring Basics

The maximum system capacity is 4000 ft. (1219.2 m) of cable and 32 devices. The baud rate can restrict the maximum cable length.

- Wiring is done in a strict daisy chain without taps or stars.
- 120 ohm 1/4W end of Line Termination Resistors (EOLTR) are required at each end of the cable.
- Attach like terminals to like terminal types for each RS485 port being networked.
- Tie the communication cable shield wire to ground at one location only.
- Data line definition - as per the RS485 standard - in an idle marked state (logic 1) Data B (+) will be electrically > than Data A (-).

Note: When connecting to third party RS485 devices, their data line nomenclature may be inverted. If the RXD LED is on continuously, this indicates a crossed data pair.

- The use of ferrules to terminate the cable ends is strongly recommended to minimize problems with frayed wires and to strengthen the terminal block connection, when daisy chaining wires use a dual wire ferrule.

Phoenix Contact and many other vendors carry ferrules and crimping tools for this purpose.

For more information about RS485 wiring, please refer to TD 17513, Eaton Electrical field Devices Communication Wiring Specification.

4. Ratings

4.1. Environmental Ratings

Meter - UL50/NEMA type 1, IP30

- Pollution Degree II

Temperature range -20 to 70°C (-4 to 158°F).

Elevation 0 to 6.9.6 ft. (0 to 2000 m)

Humidity 5 - 95% (non condensing)

4.2. PowerXpert I/O Board (PXMIO Card)

This optional card provides for external discrete IO interfacing

IO1 - 8 Discrete inputs to external dry contacts

- IO11 - IO18 ~ 10 mA sink input
- IO19 - 24 V internal source for all inputs

IO2 - 2 Solid State relays - external source and load limited to 30 VDC and 100 mA.

- IO21/IO22 Solid State Output 1 (logic also tied to S1 LED)
- IO23/IO24 Solid State Output 2

IO3 - 3 Electro mechanical Relays rated for 240 VAC/30 VDC @ 5 Amps

- IO31 R1A - Form A Contact Relay1
- IO32 R1C - Common Relay 1
- IO33 R1B - Form B Contact Relay 1
- IO34 R2A - Form A Contact Relay2
- IO35 R2C - Common Relay 2
- IO36 R2B - Form B contact Relay 2
- IO37 R3A - Form A contact Relay 3
- IO38 R3C - Common Relay 3
- IO39 R3B - Form B Contact Relay 3

4.3. Electrical Ratings

PXPS-1 Standard Power Supply

- Voltage rating 100 - 240 VAC, 110 - 250 VDC
- Maximum Power Rating 50 W max,
- Installation Category CAT III

PXPS-4 Optional Low Voltage Power Supply

- Voltage Rating 24 - 48 VDC
- Maximum Power Rating 50 W max.
- Installation Category CAT III

Metering Circuits

- CT Current Inputs
- 5 A nominal, 20 A max. (ANSI class 20)
- Installation Category CAT III

VT or Vx Voltage Inputs

- 600 V L:L or 347VL:G
- Installation Category CAT III

4.4. Meter and Display Cleaning instructions

If the meter or display require cleaning the power and metering inputs should be turned off through their disconnects. The meter and display should be cleaned with a dry clean cloth only, no water or solvents should be used.

NOTES:

Power Xpert Meter 4000/6000/8000
Quick Start Guide

Eaton
Electrical Sector
1000 Eaton Boulevard
Cleveland, OH 44122
United States
877-ETN-CARE (877-386-2273)
Eaton.com

© 2017 Eaton
All Rights Reserved
Printed in USA
Publication No. IB02601007E / TBG001350
January 2017



All trademarks are property of their
respective owners.