

Power Xpert® Meter 4000/6000/8000 Quick Start Guide



Copyright © 2012 by Eaton Corporation. All rights reserved.

Specifications and information contained herein are subject to change without notice.

Power Xpert and PowerVision are registered trademarks of Eaton Corporation.

EATON CORPORATION - CONFIDENTIAL AND PROPRIETARY NOTICE TO PERSONS RECEIVING THIS DOCUMENT AND/OR TECHNICAL INFORMATION

THIS DOCUMENT, INCLUDING THE DRAWING AND INFORMATION CONTAINED THEREON, IS CONFIDENTIAL AND IS THE EXCLUSIVE PROPERTY OF EATON CORPORATION, AND IS MERELY ON LOAN AND SUBJECT TO RECALL BY EATON AT ANY TIME. BY TAKING POSSESSION OF THIS DOCUMENT, THE RECIPIENT ACKNOWLEDGES AND AGREES THAT THIS DOCUMENT CANNOT BE USED IN ANY MANNER ADVERSE TO THE INTERESTS OF EATON, AND THAT NO PORTION OF THIS DOCUMENT MAY BE COPIED OR OTHERWISE REPRODUCED WITHOUT THE PRIOR WRITTEN CONSENT OF EATON. IN THE CASE OF CONFLICTING CONTRACTUAL PROVISIONS, THIS NOTICE SHALL GOVERN THE STATUS OF THIS DOCUMENT.

DISCLAIMER OF WARRANTIES AND LIMITATION OF LIABILITY

The information, recommendations, descriptions and safety notations in this document are based on Eaton Electrical Inc. and/or Eaton Corporation's ("Eaton") experience and judgment and may not cover all contingencies. If further information is required, an Eaton sales office should be consulted.

Sale of the product shown in this literature is subject to the terms and conditions outlined in appropriate Eaton selling policies or other contractual agreement between Eaton and the purchaser.

THERE ARE NO UNDERSTANDINGS, AGREEMENTS, WARRANTIES, EXPRESSED OR IMPLIED, INCLUDING WARRANTIES OF FITNESS FOR A PARTICULAR PURPOSE OR MERCHANTABILITY, OTHER THAN THOSE SPECIFICALLY SET OUT IN ANY EXISTING CONTRACT BETWEEN THE PARTIES. ANY SUCH CONTRACT STATES THE ENTIRE OBLIGATION OF EATON. THE CONTENTS OF THIS DOCUMENT SHALL NOT BECOME PART OF OR MODIFY ANY CONTRACT BETWEEN THE PARTIES.

In no event will Eaton be responsible to the purchaser or user in contract, in tort (including negligence), strict liability or otherwise for any special, indirect, incidental or consequential damage or loss whatsoever, including but not limited to damage or loss of use of equipment, plant or power system, cost of capital, loss of power, additional expenses in the use of existing power facilities, or claims against the purchaser or user by its customers resulting from the use of the information, recommendations and descriptions contained herein.

Table of Contents

- 1 Introduction 5**
 - Safety Precautions 5
- 2 Quick Start Guide for the Meter Module..... 7**
 - Safety Precautions 7
 - VT , VX & CT Connections..... 10
 - Establishing Communications between the Meter
Module and the Optional Graphic Display Module 11
 - Operating the Display Module 13
 - Programming the Meter Module using the Embedded
Web Server Interface 14
 - Programming the Meter Module via the Optional
Communications Expansion Card 15
- 3 Mounting and Wiring 19**
 - Mounting the Display Module and Meter Module Separately 19
 - General Instructions..... 19
 - Wiring 22
 - Fuses 24
 - Hipot and Megohm (Megger) Testing 25
 - Communication Wiring 25
 - RS485 Network..... 25
 - RS485 Network..... 25
 - RS485 Cable Characteristics..... 26
 - RS485 Wiring Basics..... 26
 - Display Unit Mounting Template 29

1 INTRODUCTION

Safety Precautions

All safety codes, safety standards and/or regulations must be strictly observed in the installation, operation and maintenance of this device.



WARNINGS refer to a hazardous situation which, if not avoided, could result in death or serious injury.



CAUTIONS refer to a hazardous situation which, if not avoided, could result in equipment damage.

WARNINGS

SHOCK HAZARDS:

IMPROPER INSTALLATION CAN CAUSE DEATH, INJURY AND/OR EQUIPMENT DAMAGE. Follow all Warnings and Cautions. Completely read and understand the information in this document before attempting to install or operate the equipment. Improper wiring could cause death, injury and/or equipment damage. Only qualified personnel are to service the Power Xpert® Meter.

TROUBLESHOOTING PROCEDURES MAY REQUIRE PROXIMITY TO EXPOSED ENERGIZED (LIVE) ELECTRICAL WIRING AND/OR PARTS WHERE THE HAZARD OF FATAL ELECTRIC SHOCK IS PRESENT.

Exercise extreme care to avoid injury or death. Always disconnect, lock-out and tag the current and voltage sources and the control power supply circuit before touching the connections or components on the rear face of the meter base unit.

FAILURE TO GROUND THE POWER XPERT® METER MAY RESULT IN INJURY, DEATH OR EQUIPMENT DAMAGE.

Properly ground the Power Xpert® Meter during installation.

2 QUICK START GUIDE FOR THE METER MODULE

2.1. Safety Precautions

All safety codes, safety standards and/or regulations must be strictly observed in the installation, operation and maintenance of this device.

 **WARNINGS** refer to instructions that, if not followed, can result in death or injury.

 **CAUTIONS** refer to instructions that, if not followed, can result in equipment damage.

 **WARNINGS**

SHOCK HAZARDS:

IMPROPER INSTALLATION CAN CAUSE DEATH, INJURY AND/OR EQUIPMENT DAMAGE. Follow all Warnings and Cautions. Completely read and understand the information in this document before attempting to install or operate the equipment. Improper wiring could cause death, injury and/or equipment damage. Only qualified personnel are to service the Power Xpert Meter 4000/6000/8000 and Graphic Display.

TROUBLESHOOTING PROCEDURES MAY REQUIRE PROXIMITY TO EXPOSED ENERGIZED (LIVE) ELECTRICAL WIRING AND/OR PARTS WHERE THE HAZARD OF FATAL ELECTRIC SHOCK IS PRESENT. Exercise extreme care to avoid injury or death. Always disconnect, lock-out and tag the current and voltage sources and the control power supply circuit before touching the connections or components on the rear face of the Power Xpert Meter 4000/6000/8000 and Graphic Display.

FAILURE TO GROUND THE POWER XPERT METER MAY RESULT IN DEATH, INJURY OR EQUIPMENT DAMAGE. Properly ground the Meter Module during installation.

IMPROPER ASSEMBLY AND INSTALLATION OF THE CT TERMINAL BLOCK AND STRAIN RELIEF HOOD MAY RESULT IN OPEN CIRCUITED CTS AND EXPOSURE TO DANGEROUS VOLTAGES WHICH MAY RESULT IN SEVERE INJURY OR DEATH.

Terminal block hoods are provided with the metering current and voltage terminal blocks. The current terminal block retaining screws are part of the matching hood assembly. The current terminal block and hood assembly must be properly installed with retaining screws to secure the current terminal block to the meter housing to prevent exposure to shock hazard.

2.2. Power Supply Connections

1. Connect the Power Supply (PXMP5-1)

The Meter Module is powered using a 100-240Vac or 110-250Vdc (PXMP5-1) standard power supply.

- PS1-3 connected to ground
- PS1-2 connected to Neutral (Vac) or (-)Vdc
- PS1-1 connected to Line (Vac) or (+) Vdc

Fabricate a power cord of suitable length and connect to the power supply via the Power Supply Connection shown in **Figure 1**. (Note: The Green Health LED should blink at a slow rate (once per second). If it blinks at a faster rate, see the Troubleshooting chapter in the manual. The Red Status LED will blink if unacknowledged or uncleared events exist.

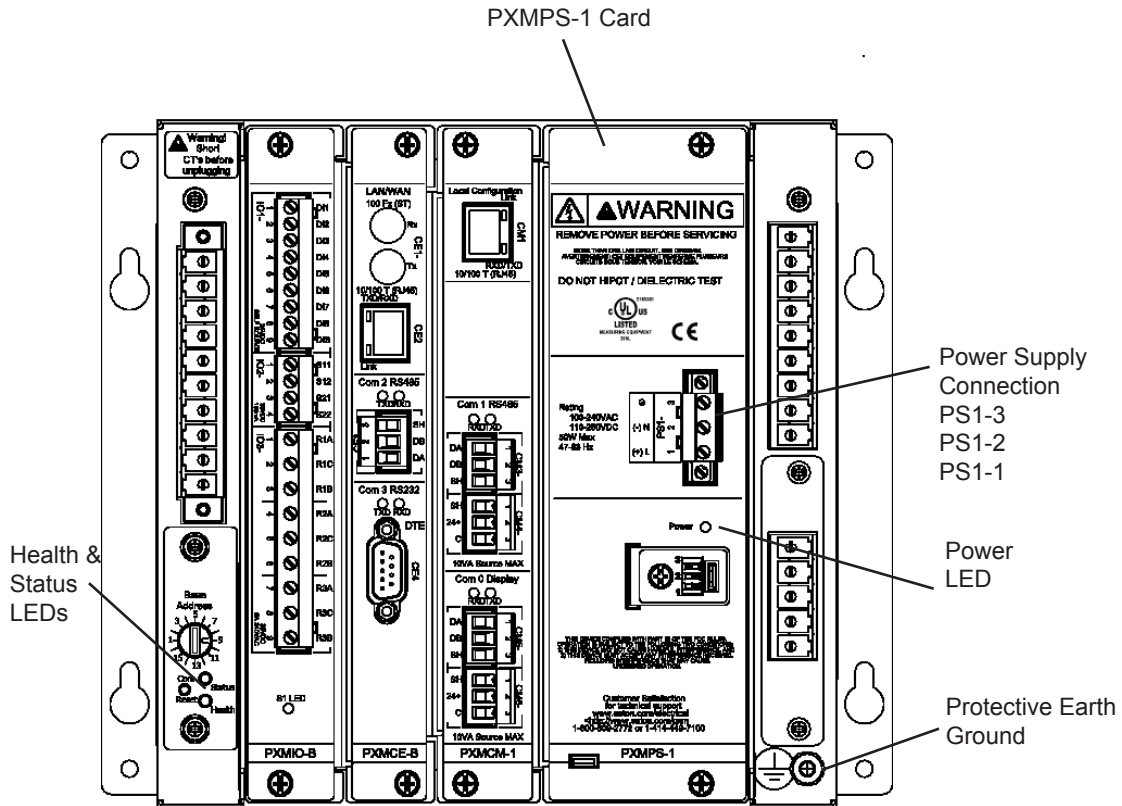





Figure 1: Meter Module Power Supply Connection & LED Locations

2. Configure the Security Mode Dip Switches:

DS-1	DS-2	DS-3		
OFF	OFF	ON is Normal. OFF is Safe Mode	No restrictions (user ID/Password required) ADMIN/ADMIN accepted for 15 minutes after boot-up	
OFF	ON	ON is Normal. OFF is Safe Mode	Medium Security - Energy & Demand resets prohibited	
ON	OFF	ON is Normal. OFF is Safe Mode	High Security- Configuration changes; Energy & Demand reset prohibited	
ON	ON	ON or OFF	Factory Test Mode - The meter should never be operated in this mode. The meter will indicate that it's in factory test mode through a repeating series of three flashes on the red Status LED	

3. Planning CT and VT Connections (Figure 3)

Determine your wiring requirements for the meter module. This quick start guide will cover these basic wiring configurations:

- 3-Phase, 3-Wire Delta(Up to 600 V L-L, 347 L-N) 3CTs
- 3-Phase, 3-Wire Delta (Above Up to 600 V L-L, 347 L-N) 3CTs
- 3-Phase, 3-Wire Delta (Above Up to 600 V L-L, 347 L-N) 2 CTs
- 3-phase,4-Wire Y (Up to Up to 600 V L-L, 347 L-N)
- 3-phase,4-Wire Y (Above Up to 600 V L-L, 347 L-N)

See Installation, for wiring diagrams.

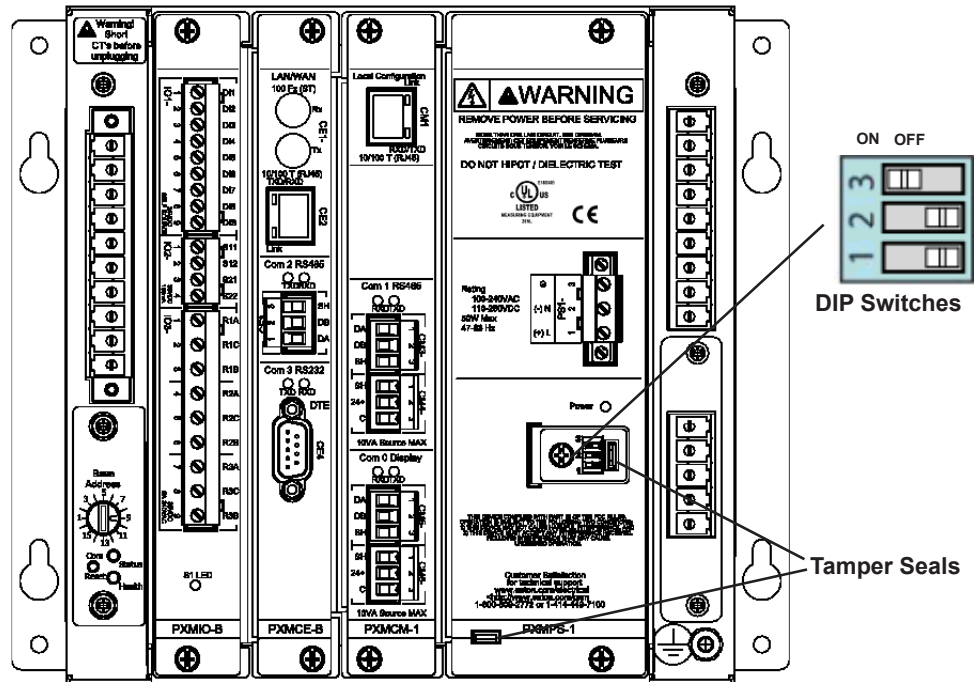

Figure 2: Meter Module's Dip Switches & Tamper Seals

2.3. VT , VX & CT Connections

VT Terminal Voltage Connections:

Voltage Inputs can accept up to 600Vac L:L / 347VL:G direct. A PT with a 120V secondary is required If this rating is exceeded. Primary settings are 120-500,000, for a PT ratio of 120:120 to 500000 to 120. It is strongly recommended that the Voltage Inputs be connected to the Meter Module by way of properly rated disconnect switches.

- VTV1 = Line 1 or Va
- VTV2 = Line 2 or Vb
- VTV3 = Line 3 or Vc
- VTV4 = Line 4 or Vn (neutral)
- VTVR = Metering Reference Ground

VX Optional Auxiliary Voltage Connections:

- VXV6 = Line 1' or Va2
- VXV7 = Line 2' or Vb2
- VXV8 = Line 3' or Vc2

CT Terminal Connections:

Current Inputs accepts a 5-amp secondary with available Primary settings of 5-9999, for a CT ratio of 5:5 to 9999:5. It is strongly recommended that the Current Inputs be connected to the Meter Module by way of a shorting block.

- Line 1 CT connected to Terminals 11 (polarity mark) & 12 (return)
- Line 2 CT connected to Terminals 21 (polarity mark) & 22 (return)
- Line 3 CT connected to Terminals 31 (polarity mark) & 32 (return)
- Neutral CT connected to Terminals 41 (polarity mark)& 42 (return)
- Ground CT connected to Terminals 51 (polarity mark)& 52 (return)

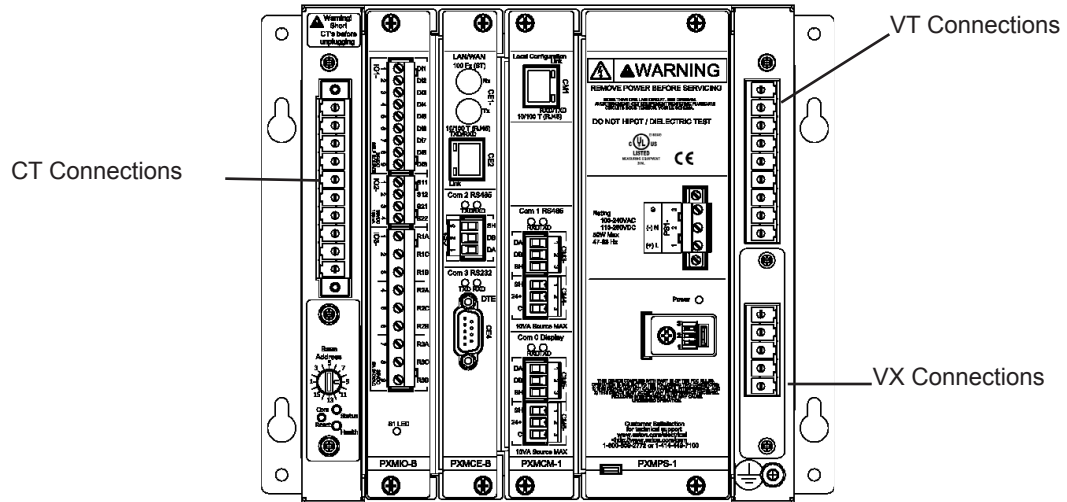

Figure 3: CT & VT Connections

2.4. Establishing Communications between the Meter Module and the Optional Graphic Display Module

1. Establishing communication between the Graphic Display Module and Meter Module:

A. Using an RS485 cable, connect COM 0 (**Figure 4**) on the back of the Display Module to COM 0 (**Figure 5**) found on the Meter Module (RS485 Comms). See table below and the Cable Specifications Table for wiring.

Description	Display		PXCM	
	Terminal	Cable	Terminal	
DA	DG1-1	TP	CM5-1	
DB	DG1-2	TP	CM5-2	
SH	DG1-3	SDW	CM5-3	

TP=Twisted Pair

SDW = Shield Drain Wire

B. Connect CM6 (**Figure 5**) located on the CM card to DG2 (**Figure 4**) on the Display Module to supply power (24V) to the Display Module. See table below for wiring.

Description	Display		PXCM	
	Terminal	Cable	Terminal	
SH	DG2-1	OSCS	CM6-1	
24+	DG2-2	TP	CM6-2	
COM	DG2-3	TP	CM6-3	
Gnd	DG2-4	To local panel ground		

OSCS=Optional Separate Cable Shield

(OSCS used for separate power and data cables)

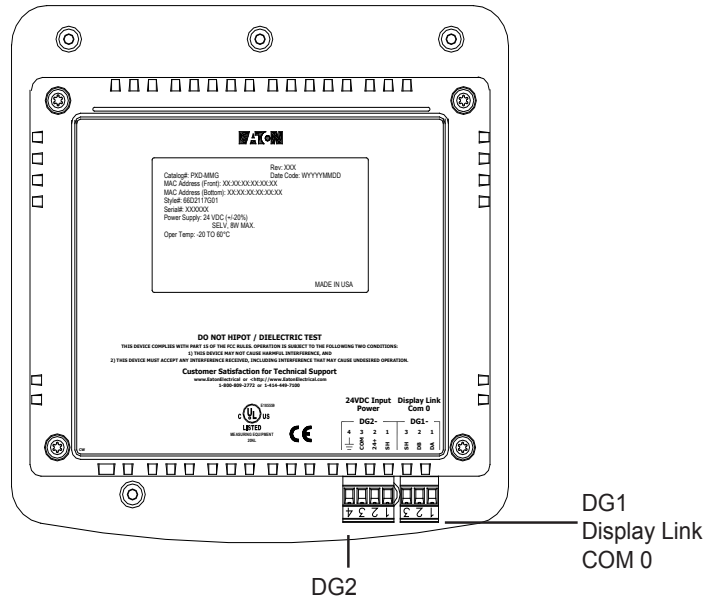

Figure 4: Display Module Connections to Base Unit

C. Set the Rotary Switch (Figure 5) located on the side of the Meter Module unit to a number 1 through 16.

NOTE: The Display Module can communicate to a maximum of 16 Meter Modules by connecting the Meter Module’s COM 0 together following basic RS485 wiring specifications. Each Meter Module will need to be uniquely addressed using the Rotary Switch.

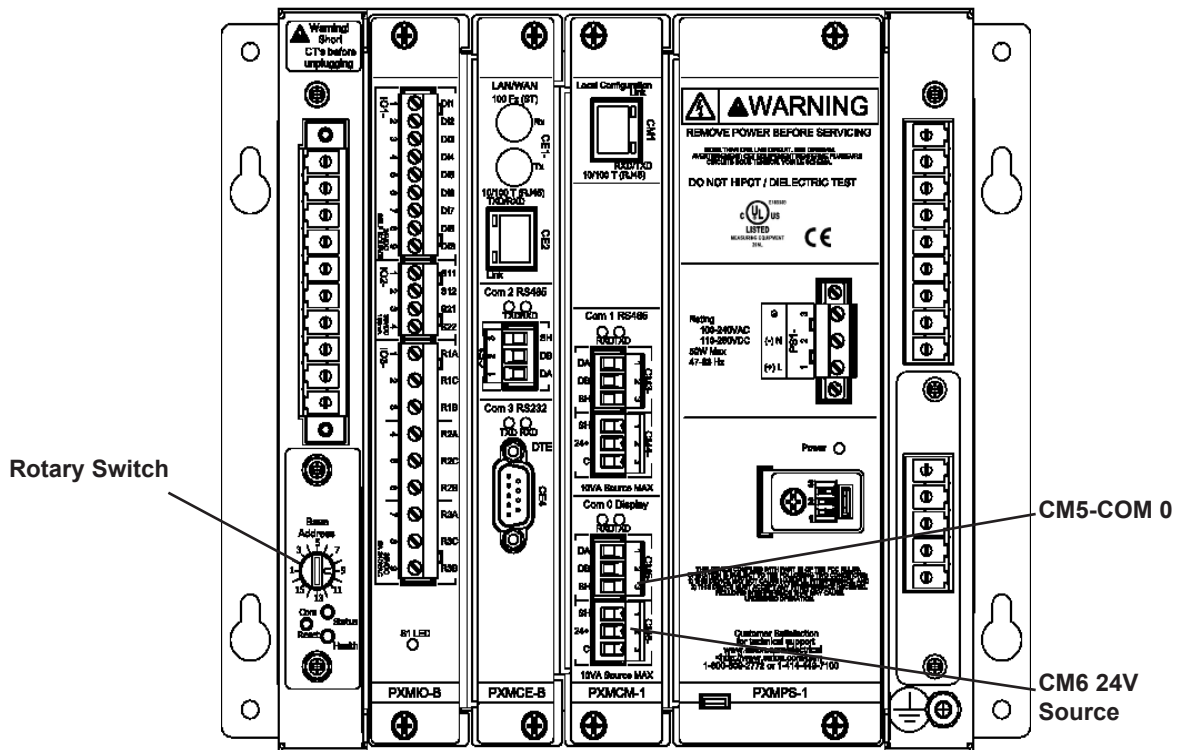

Figure 5: Meter Module Connections to Display

2.5. Operating the Display Module

The Display Module (**Figure 6**) is an easy-to-use, intuitive interface to the Meter Module. It has the following features:

- Navigation Dial - Turn clockwise and counterclockwise to select (highlight) options on the screen. Once highlighted, push dial to get more information about the topic.
- Back Button - Push to return to the previous selection.

Display Health LED - If Display Module is powered-up, the LED will blink slowly (1/sec).

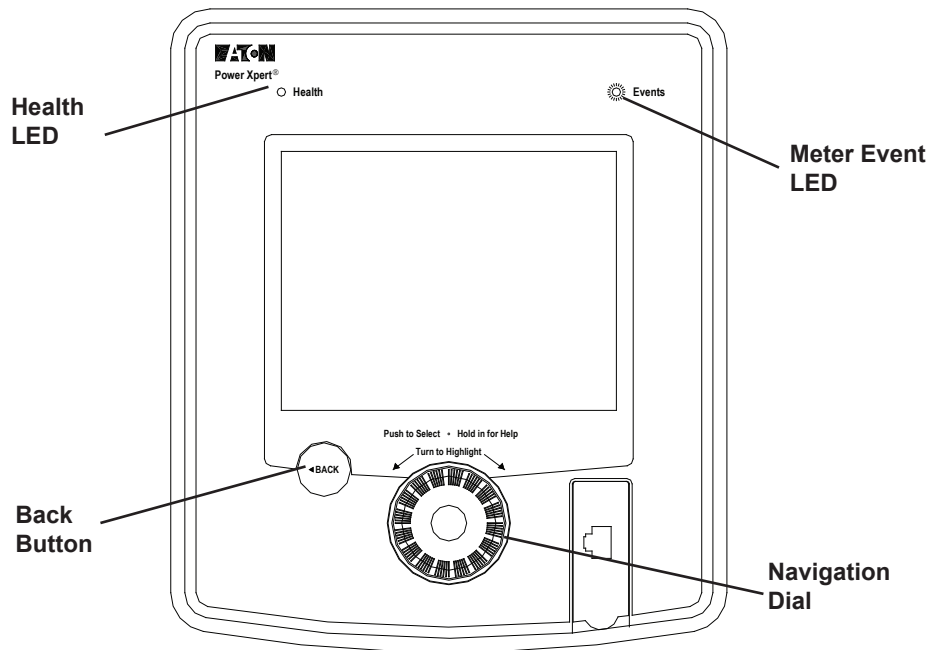
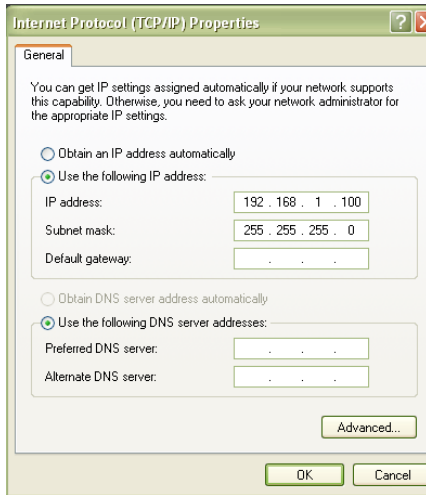

Figure 6: Display Module Controls

2.6. Programming the Meter Module using the Embedded Web Server Interface

NOTE: The set up of the Ethernet ports on the CE card must be done through the local configuration port of the CM card or with the display. After the CE Ethernet port is configured, the meter can be programmed remotely through the LAN/WAN connection.

1. Connecting a laptop to the meter module using the local Ethernet browser interface CMI:



A. Install Java (if not already on the PC). To do this, download the latest version of Java J2SE JRE (Java Runtime Environment) from www.java.sun.com and install it.

B. Connect the Laptop to the Meter Module via CM1 port (see figure 7 below) using a UTP **Cat5 Patch Cable**. Note that the IP address of the CM1 port is permanently configured to be 192.168.1.1.

C. Set the laptop's IP address to 192.168.1.100 by completing the following steps:

- Click Window's Start. Then click Settings > Control Panel (Windows 2000) or Control Panel (Windows XP/Vista).
- In Control Panel, click Network and right-click Local PC Area Connection. Select Properties from the shortcut menu.
- In the Properties dialog, select Internet Protocol (TCP/IP) and click the Properties button.
- In the Internet Protocol (TCP/IP) Properties window, select "Use the following IP address" and then enter the following IP address 192.168.1.100, with a Subnet Mask set to 255.255.255.0.
- Click OK.

Launch Internet Explorer and then navigate to <http://192.168.1.1>, then go to Step 2 in Section 2.6.

NOTES: When connected to a laptop, the Link LED will illuminate and, when communicating, the TXRX LED will flicker.

For PXC Cards, the local configuration port may require the use of a UTP Cat 5 cross over cable. The PXMCM card accepts a standard Cat 5 patch cable.

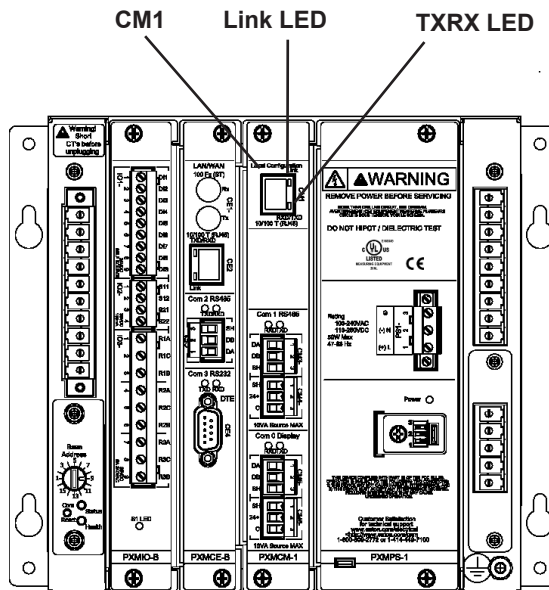

Figure 7: Connect Laptop to Meter Module

2.7. Programming the Meter Module via the Optional Communications Expansion Card

The Optional Communications Expansion (CE) card (see figure 8 below) provides LAN/WAN Web Ethernet communication via either Fiber (CE1) or UTP/STP Cat5 cable (CE2). It also provides communication via Modbus RTU (CE3 & CE4 – see Appendix A of the manual for Modbus instructions).

Note: The CE card is generally installed by the factory at time of manufacture. If the card is installed as an after sale option, follow instructions for physical installation that accompany the card or refer to the manual. To set up the card follow these steps:

- A. The meter ships DHCP and CE2 enabled. Connect the standard cable (blue) from CE2 to network. Because DHCP is enabled, the user must find the IP address via the Local Configuration port [Setup->Diagnostics->Communication->Ethernet] or Local Display.

NOTE: CE1/2 are multiplexed by setpoints.

- B. Power cycle the meter to initiate DHCP. If DHCP is not used, an IP address will need to be assigned.

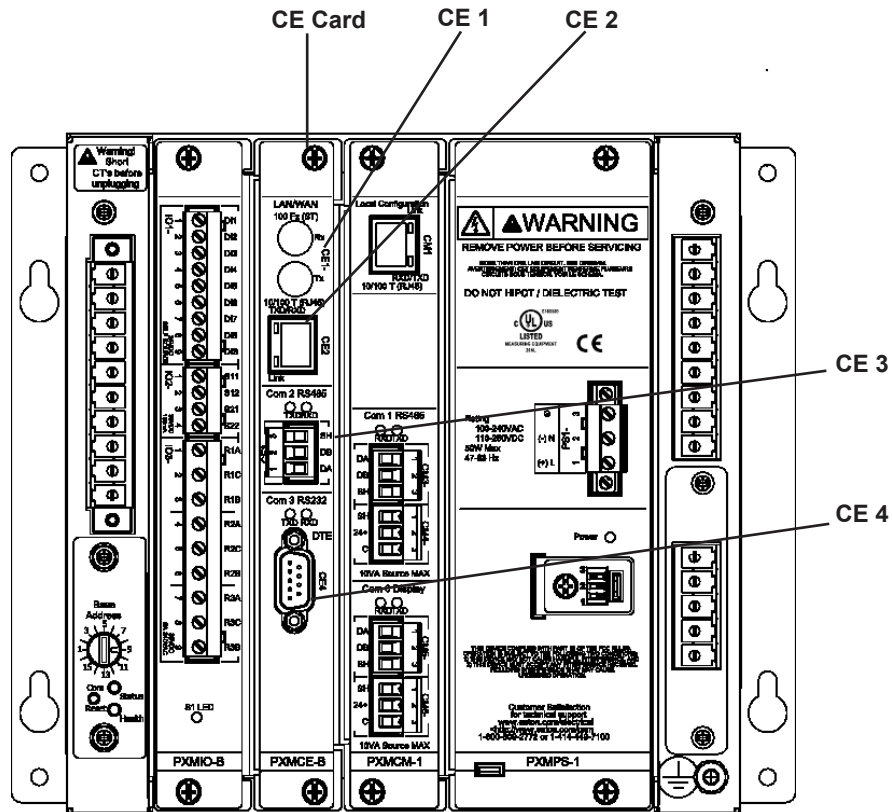
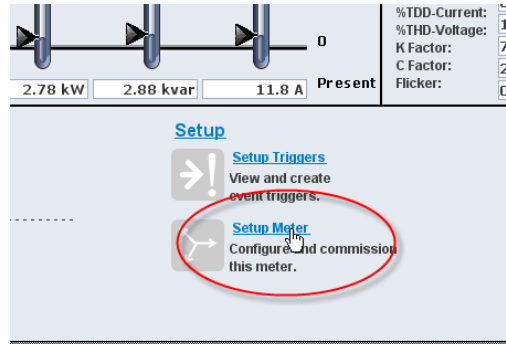

Figure 8: Ethernet & Modbus Connections

For further details about the following steps, refer to Setup on the Web Server Screens/ Setup on the Local Graphical Display respectively.

1. Start Internet Explorer. After “http:\”, type in the IP address of the CE Ethernet port in the address box and click OK. The Meter Webserver Home Page will be displayed. (If DHCP is enabled, the user must find the IP address via the Local Configuration port [Setup->Diagnostics->Communication->Ethernet] or Local Display).
2. On the Meter Webserver home page, click Setup Meter.



3. Login to the Meter Module by clicking on the Login/Change Users button.

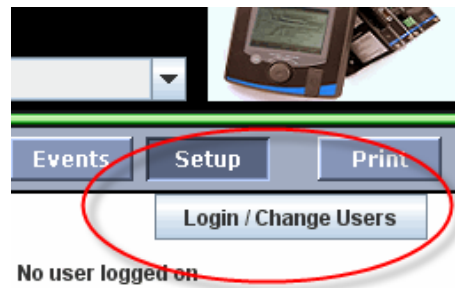

4. Type the Name and Password. The defaults are: Name = admin and Password = admin. After entering the Name and Password, click OK.

Note: Without logging into the meter, data is read-only.

Name:

Password:

5. From the setup menu, click Quick Setup to display basic configuration setup.

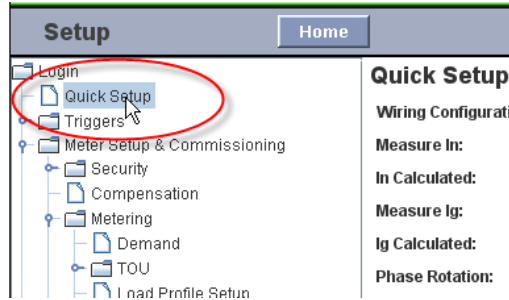

6. Click Edit to make changes to these parameters.

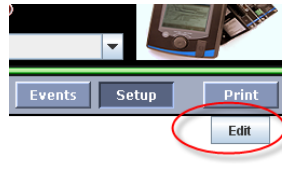

7. Set the clock by clicking on Meter Setup & Commissioning > Clock > Edit.

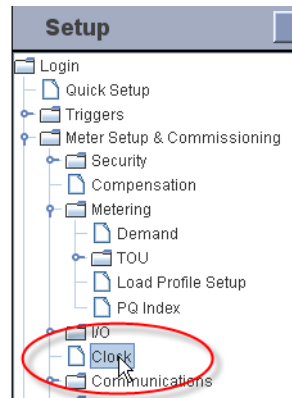

Notes on Modbus support:

The Optional Communications Expansion (CE) card also provides communication via Modbus RTU (CE3 & CE4 – see manual for Modbus instructions) The RS485 CE3 port supports Modbus RTU slave to a master monitoring system. The port defaults as a Master Gateway, which relays Ethernet Modbus TCP command to slave meters connected to the same RS485 link. The Modbus slave address may be set via the display module or with a web browser.

3 MOUNTING AND WIRING

WARNING

SHOCK HAZARD: VERIFY THAT ANY INCOMING AC POWER OR FOREIGN POWER SOURCES ARE TURNED OFF AND LOCKED OUT BEFORE PERFORMING ANY WORK ON THE POWER XPERT 4000/6000/8000 METER OR ASSOCIATED EQUIPMENT. FAILURE TO DO SO CAN RESULT IN INJURY TO PERSONNEL OR DAMAGE TO EQUIPMENT.

The Power Xpert Meter 4000/6000/8000 is designed to be installed, operated and maintained by adequately trained personnel. These instructions do not include all details, variations or combinations of the equipment, its storage, delivery, installation, checkout, safe operation or maintenance. Compliance with local, state and national regulations, as well as with industry standard safety practices for this class of equipment, is imperative. This section describes mounting, wiring, startup and miscellaneous details associated with the Power Xpert Meter 4000/6000/8000. Every section should be reviewed prior to installing this device.

3.1. Mounting the Display Module and Meter Module Separately

1. Prepare a cutout in which Display will be placed. The dimensions for this cutout with the mounting hole locations are shown in Panel Cutout figure (page 20)). There's a 1:1 template you can remove from the manual or copy on page 29.
2. Before cutting the panel, check the required three-dimensional clearances for the Display case, particularly behind the panel (see the dimension drawing on page meter). If mounting on a swinging door, check the swinging clearance of rear projections and wired connections. Remember to allow for: extra space for all wiring (including an additional 2" for the bending radius (4" for fiber optic), intermediate terminal strips, shorting blocks or other required components. Dimensions in Display Module figure on page 21.
3. It is necessary to hold several tolerances when making the cutout and placing the holes for the mounting screws. The holes must be located within 1/16" of the drawing specifications, and a .188" to 3/16" drill bit is recommended.
4. Place the Display module through the panel cutout. Using the five #8-32X1/2" screws, attach the Display to the panel. It is best to attach the top center screw first.
5. To mount the Meter Module directly to a flat panel, as recommended, a panel cutout is not necessary. There are eight hole locations on the Meter module Mounting Brackets; four circular holes and four keyholes. Use either set for mounting. See the Meter Module figure on page 21 for the hole sizes and locations.

3.6. General Instructions

It is recommended that the Power Xpert 4000/6000/8000 Meter be mounted in an electrical switchgear enclosure that is suitable for its environment. The Power Xpert Display and Meter Modules are generally mounted separately (see manual for mounting together). While it is recommended that the Display Module be door or panel mounted, the Meter Module can be mounted remotely from the Display Module on a flat surface or panel elsewhere in the enclosure.

- The Meter Module must remain vertical at all times to maintain proper ventilation.
- The Display and Meter Modules may be installed in a Pollution Degree II environment.
- If the Meter Module is mounted remotely, the Display Module MUST be connected to earth ground.
- The Meter Module should be protected from accidental contact with live terminals in the enclosure. A 1/8 inch steel panel or door, solidly grounded, is recommended.

- The Meter Module comes standard with the remote mounting brackets attached.
- The Display Module comes standard with the required hardware, five #8-32 x .50 LG Phillips Pan Int SEMS Screws, for mounting the unit to a door or panel.

Panel Cutout Dimensions for Display Module [in/(mm)]

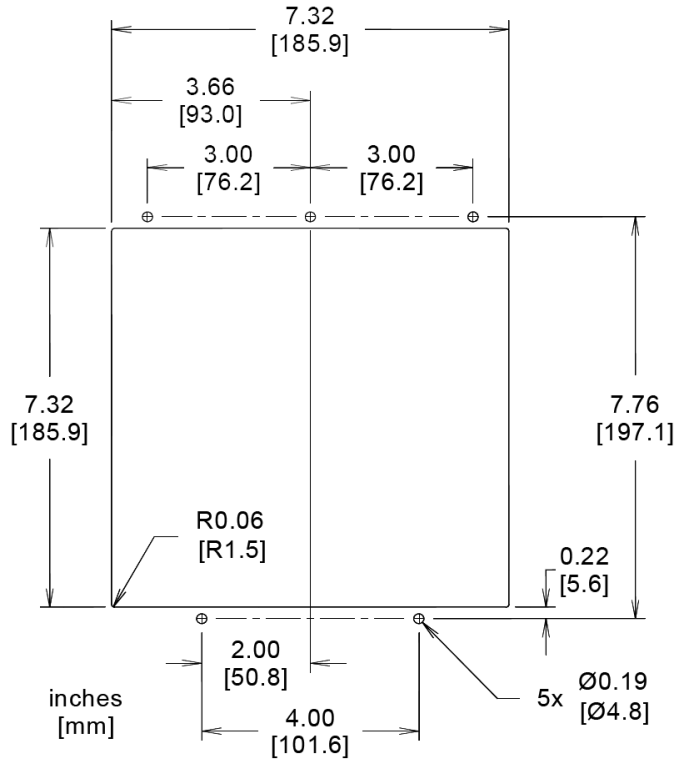

Display Panel Cutout

Power Xpert 4000/6000/8000 Meter Module

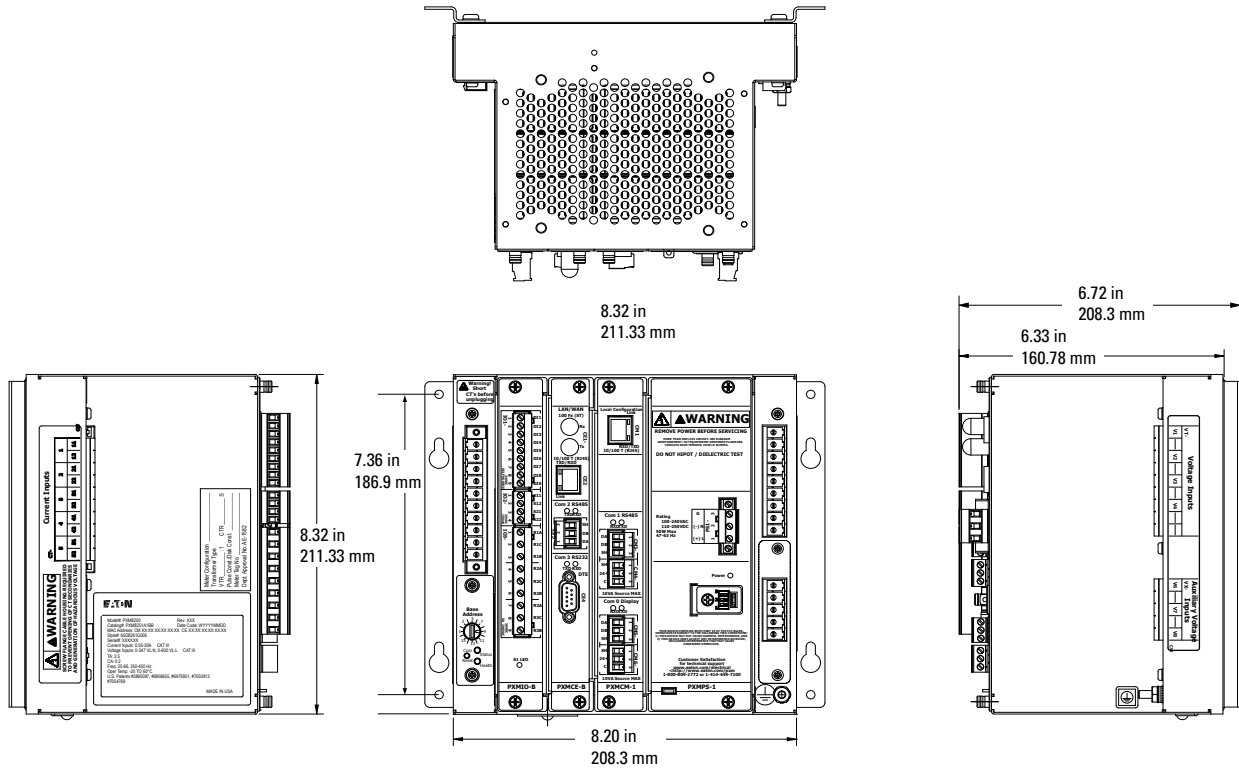

Power Xpert 4000/6000/8000 Display Module

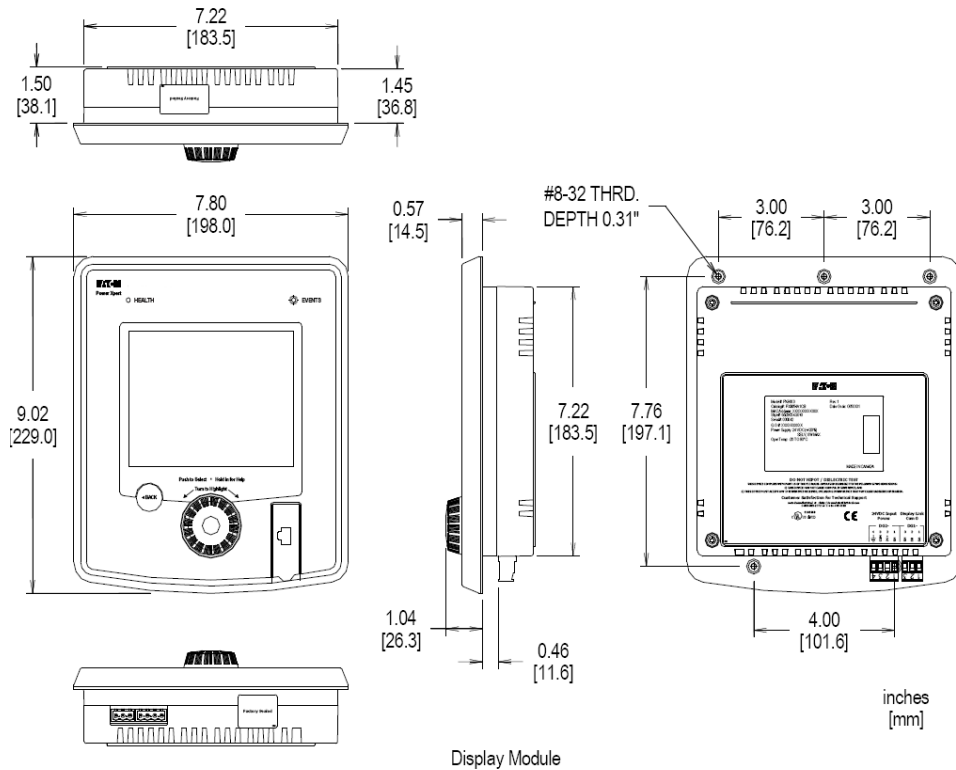

3.7. Wiring



Wiring of the Power Xpert® Meter must follow a suitable wiring plan drawing. The phase wiring plan refers to the drawings made for the specific application. It describes all electrical connections between the meter and external equipment. A network wiring diagram can also be helpful for networked systems. Specific wiring diagrams are useful when creating the overall wiring plan drawing. Wiring diagrams for each system configuration are addressed below.

WARNINGS

SHOCK HAZARDS:

IF THIS DEVICE IS BEING USED ON A SINGLE PHASE SYSTEM, WIRE TO PHASE A AND NEUTRAL.

The following general considerations should be complied with during the wiring of the Power Xpert® Meter.

All wiring must conform to applicable Federal, State and Local codes.

The wires to the terminal blocks must not be larger than AWG No. 10 (CT, VT, VX). Larger wire will not connect properly to the terminal block.

Wiring diagrams contacts are shown in their de-energized position.

Because the Power Xpert® Meter monitors the neutral-to-ground voltage, the chassis of the meter must be connected to ground. A good low impedance ground is essential for proper functioning.

PT AND CT SECONDARY CIRCUITS ARE CAPABLE OF GENERATING DANGEROUS VOLTAGES AND CURRENTS WITH THEIR PRIMARY CIRCUITS ENERGIZED, AND COULD CAUSE PERSONAL INJURY AND OR DEATH.

The proper selection of any required current transformers or potential transformers is critical to the proper and accurate functioning of the Power Xpert® Meter. Instrumentation grade devices are required. **Shorting blocks for CTs and a three-phase switch or circuit breaker for voltage are recommended near the equipment for ease of installation.** If assistance with the selection process is desired, contact Power Quality Technical Support representative.

Wiring Diagrams

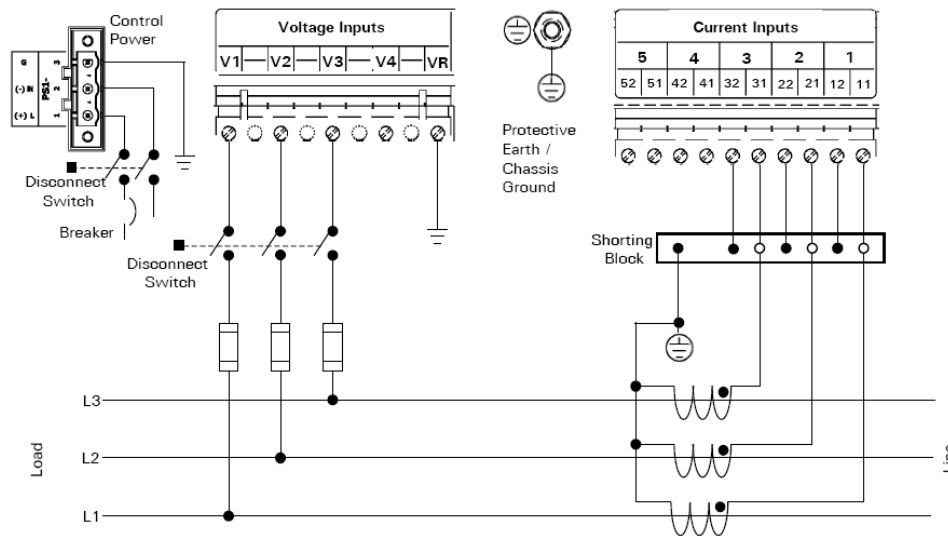

Based upon the voltage rating, a control power transformer may be needed for the control power.

**3 Phase 3 Wire Delta (Up to 480 Volts)
Direct Voltage Connection & External Current Transformers**

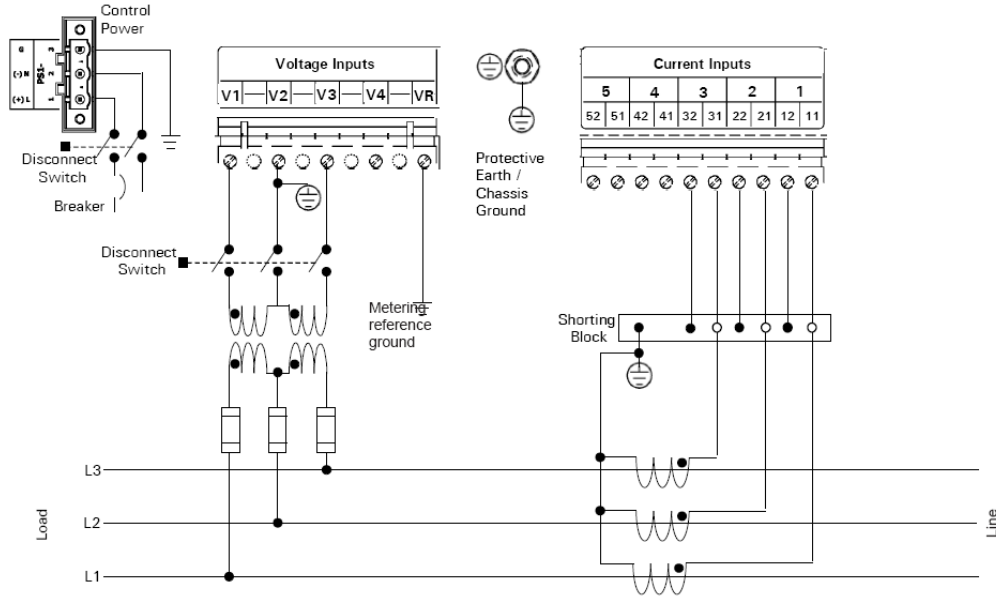

Based upon the voltage rating, a control power transformer may be needed for the control power.

**3 Phase 3 Wire Delta (Above 480 Volts)
External Voltage Transformers & Current Transformers**

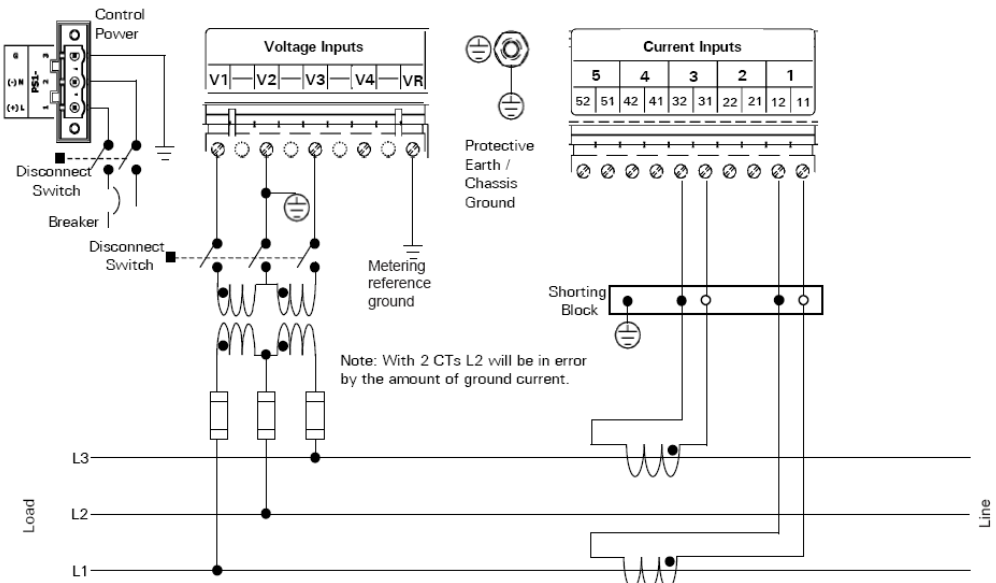

Based upon the voltage rating, a control power transformer may be needed for the control power.

**3 Phase 3 Wire Delta (Above 480 Volts) 2 CTs
External Voltage Transformers & Current Transformers**

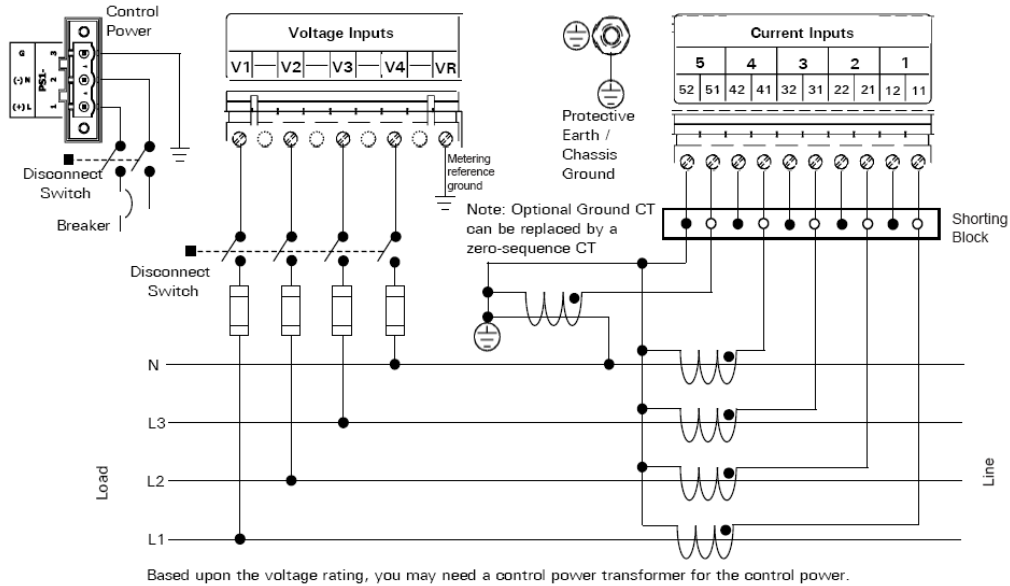

3 Phase 4 Wire Y (Up to 600 Volts)
 Direct Voltage Connection & External Current Transformers

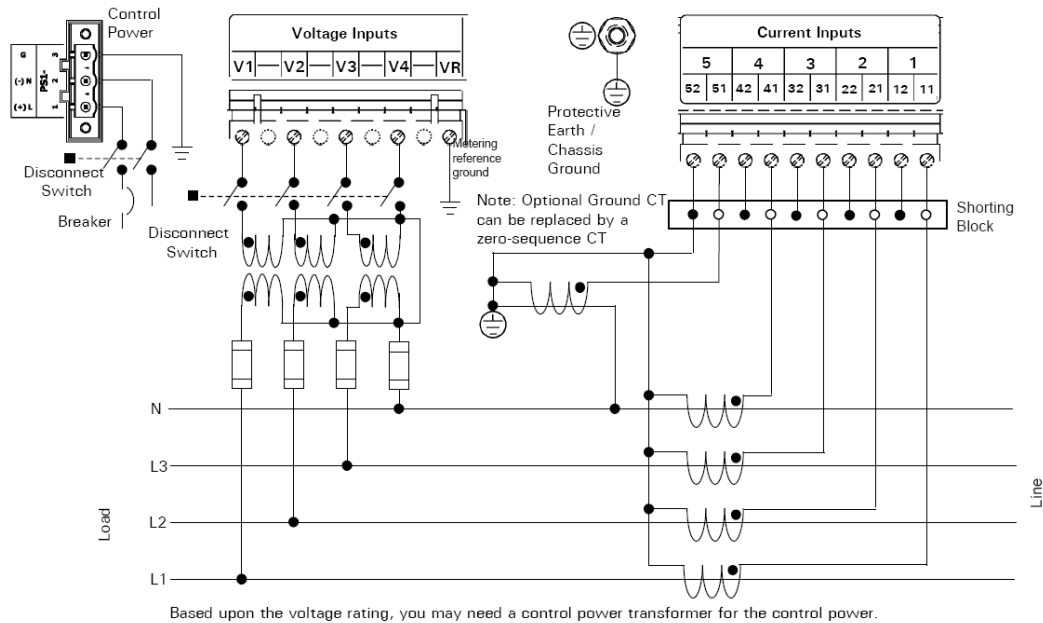

3 Phase 4 Wire Y (Above 600 Volts)
 External Voltage Transformers & Current Transformers

3.8. Fuses

It is required that user supplied fuses be installed as described below.

External fuses should be installed in the meter voltage tap to the main lines, near the meter housing. 600 V 1/2 A BUSS type KTK-R-1/2 Fast Acting or equivalent fuses are recommended for the Power Xpert® Meter VT connections.

External fuses should be installed in the potential transformer lines as specified in the National Electric Code for the specific application.

The power supply wiring should be fused or put on a breaker sized to protect the wire.

3.9. Hipot and Megohm (Megger) Testing

CAUTION

DO NOT HIPOT OR MEGOHM TEST THE METER. SEVERE DAMAGE TO THE METER CAN RESULT.

3.10. Communication Wiring

The Power Xpert® Meter (PXM 4000/6000/8000) has inverted terminal blocks for CM4 - the 24V Auxiliary I/O Power and CM6 - the Display Power. These inverted terminal blocks prevent the user from crossing 24v source and communication terminals.

RS485 fail safe biasing resistors are used at each master port.

Eaton strongly recommends using ferrules when connecting to a terminal block.

When connecting to a terminal block, the twisted pair sensitivity is critical for COM0, COM1 and COM2. This means that the Data A wire must match up with Data A on the terminal and the Data B wire must match up with Data B on the terminal.

3.11. RS485 Network

The following simplified rules apply to a given system consisting of master and slave devices. For more complex configurations please refer to standard wiring specification rules for the RS485 network.

The maximum system capacity is 4,000 feet of communication cable and 32 devices.

Make sure the twisted pair wire is recommended for RS485 network use. For reference, review the RS485 wiring spec for wiring specifications.

Tie the communication cable shield to ground only once at the RS485 master device.

Cable Specifications

Terminal	Port Name	Port Type	Port Connection	Cable Length	Cable Type	Max Baud Rate	Max Number of Devices	End of Line Termination	Star	Tap	Twisted Pair Sensitivity
CM5	COM0 Display	RS485	Terminal Plug	2,000ft / 610 M	ShieldedTwisted-Pair	115 K	16	120ohms	NO	NO	YES
CM3	COM1RS485	RS485	Terminal Plug	**4,000ft / 1,219.20 M	ShieldedTwisted-Pair	115 K	32	120ohms	NO	NO	YES
CE3	COM2RS485	RS485	Terminal Plug	**4,000ft / 1,219.20 M	ShieldedTwisted-Pair	115 K	32	120ohms	NO	NO	YES
CE4	COM3RS232	RS232	DB9	50 ft / 15 M	ShieldedCable	115 K	2(1:1)	na	NO	NO	YES
CE1	LAN/WAN	100Fx	ST	400 M	Multimode62.5 m	100M	2(1:1)	na	NO	NO	NO
CE2	LAN/WAN	10/100 T	RJ45	328 - 492 ft/100-150M	CAT5 Shielded TwistedPair / UTP*	100M	2(1:1)	na	NO	NO	NO
CM1	Local Configuration	10/100 T	RJ45	98 ft / 30 M	CAT5 Shielded TwistedPair / UTP	100M	2(1:1)	na	NO	NO	NO

**RS485 maximum cable length is dictated by baud rate. Above 38.4Kbaud the length is restricted to 2,000 ft.

3.12. RS485 Network

The following simplified rules apply to a given system consisting of master and slave devices. For more complex configurations please refer to standard wiring specification rules for the RS485 network.

The maximum system capacity is 4,000 feet of communication cable and 32 devices. Make sure the twisted pair wire is recommended for RS485 network use. For reference, review the RS485 wiring spec for wiring specifications.

Tie the communication cable shield to ground only once at the RS485 master device.

3.13. RS485 Cable Characteristics

Make sure the twisted pair wire is recommended for RS485 applications:

- Single twisted pair for data 18-24AWG
- Shield consisting of aluminized Mylar & partial coverage braid with drain wire
- Characteristic impedance ~ 120 ohms
- Data L-L capacitance ~12pf/Ft.
- Typical ratings are 75C and 300V NEC CM
- Belden Data Tray series 3074F is 600V NEC TC

3.14. RS485 Wiring Basics

The maximum system capacity is 4000 ft. of cable and 32 devices. The baud rate can restrict the maximum cable length.

- Wiring is done in a strict daisy chain without taps or stars
- 120 ohm 1/4W end of Line Termination Resistors (EOLTR) are required at each end of the cable
- Attach like terminals to like terminal types for each RS485 port being networked.
- Tie the communication cable, shield to ground, at one location only.
- Data line definition - As per the RS485 standard - In an idle marked state (logic 1) Data B (+) will be electrically > than Data A (-)

Note: When connecting to third party RS485 devices their data line nomenclature may be inverted. If the RXD LED is on continuously, this indicates a crossed data pair.

- The use of ferrules to terminate the cable ends is strongly recommended to minimize problems with frayed wires and to strengthen the terminal block connection, when daisy chaining wires use a dual wire ferrule.

Phoenix Contact and many other vendors carry ferrules and crimping tools for this purpose.

For more information about RS485 wiring, please refer to TD 17513, Eaton Electrical field Devices Communication Wiring Specification.

METER AND DISPLAY MODULE ENVIRONMENTAL RATINGS

Display Module Face – UL50/NEMA Type 12, IP42

- Pollution Degree III
- Temperature Range -20 to 60° C
- The panel enclosure must be Type 12, IP42 or better and the mounting surface flat, to preserve Display type/IP rating
- The Type12, IP42 rating requires that the Ethernet port cover is secured to display or the Ethernet cable is connected.

Display Module Back – UL50/NEMA Type 1, IP30

- Pollution Degree II

Meter Module – UL50/NEMA type 1, IP30

- Pollution Degree II

Temperature range –20 to 70° C.

Elevation 0-2000M

Humidity 5-95% (non condensing)

POWERXPRT I/O BOARD (PXMIO CARD):

This optional card provides for external discrete IO interfacing

IO1 - 8 Discrete Inputs to external dry contacts

- IO11-IO18 ~ 10mA sink input
- IO19 – 24V internal source for all inputs

IO2 – 2 Solid State relays – external source and load limited to 30VDC and 100mA.

- IO21/IO22 Solid State Output 1 (logic also tied to S1 LED)
- IO23/IO24 Solid State Output 2

IO3 – 3 Electro mechanical Relays rated for 240VAC/30VDC @ 5Amps

- IO31 R1A - Form A contact Relay1
- IO32 R1C - Common Relay 1
- IO33 R1B - Form B contact Relay 1
- IO34 R2A - Form A contact Relay2
- IO35 R2C - Common Relay 2
- IO36 R2B - Form B contact Relay 2
- IO37 R3A - Form A contact Relay 3
- IO38 R3C - Common Relay 3
- IO39 R3B - Form B contact Relay 3

METER MODULE ELECTRICAL RATINGS

PXPS-1 Standard Power Supply

- Voltage rating 100-240VAC, 110-250VDC
- Maximum Power Rating 50W max,
- Installation Category CAT III

PXPS-4 Optional Low Voltage Power Supply

- Voltage rating 24-48VDC VDC
- Maximum Power Rating 50W max,
- Installation Category CAT III

Metering Circuits

- CT Current Inputs
- 5A nominal, 20Amp maximum (ANSI class 20)
- Installation Category CAT III

VT or Vx Voltage Inputs

- 600 V L:L or 347V L:G
- Installation Category CAT III

DISPLAY MODULE ELECTRICAL RATINGS

DG1 COM0 RS485 communication port to meters, 2K' max length

- DG11 Data A (-)
- DG12 Data B (+)
- DG13 Shield (RS485 common)

DG2 Display input power 24VDC +/-10%, 6W max draw.

- DG21 Shield

- DG22 24V+
- DG23 24V common
- DG24 Display Ground – attach to local panel ground.

METER AND DISPLAY CLEANING INSTRUCTIONS

If the meter or display modules require cleaning the power and metering inputs should be turned off through their disconnects. The meter and display should be cleaned with a dry clean cloth only, no water or solvents should be used

3.15. Display Unit Mounting Template

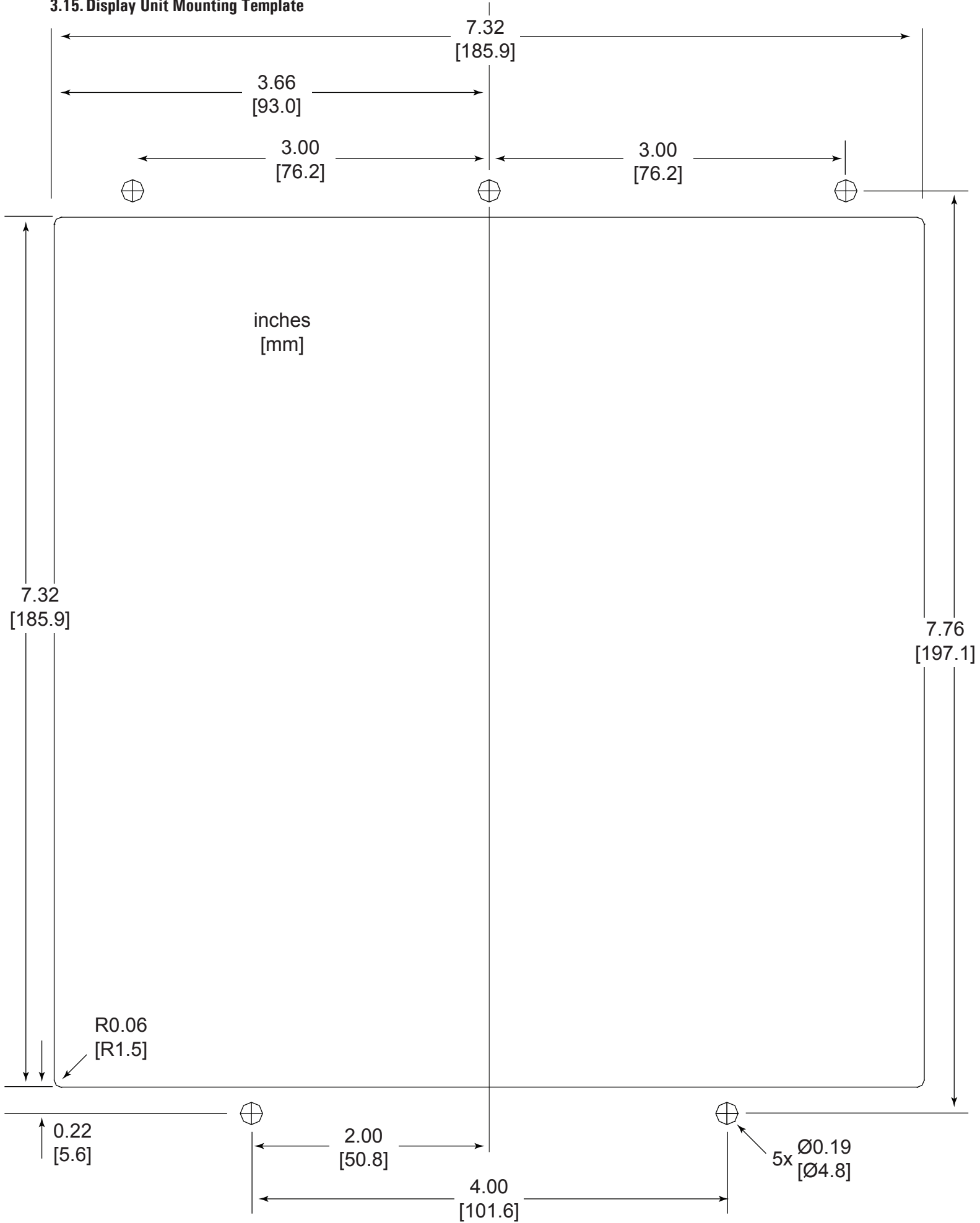

Power Xpert Meter 4000/6000/8000
Quick Start Guide

Eaton Corporation
1000 Cherrington Parkway
Moon Township, PA 15108-4312
USA

www.eaton.com

For additional information please call:

Power Quality Technical Support

1-800-809-2772 option 4

Eaton Corporation
Electrical Sector
1111 Superior Ave.
Cleveland, OH 44114
United States
877-ETN-CARE (877-386-2273)
Eaton.com

© 2012 Eaton Corporation
All Rights Reserved
Printed in USA
Publication No. IB02601007E
January 2012

EATON
Powering Business Worldwide



PowerChain
Management®

PowerChain Management is a registered
trademark of Eaton Corporation.

All other trademarks are property of their
respective owners.