

# Eaton® IQ 250 and IQ 260 Electronic Power Meters

Compact, digital meter delivers high-end power management performance



**IQ 250/260 Electronic Power Meter**

## Typical applications

- Utility and commercial metering
- Substations, industrial facilities, power generation sites and campuses
- Sub-metering
- Load studies and voltage recording
- Analog meter replacement

## Features and benefits

- Measure and display real-time information about critical power parameters with a sampling rate of 400 samples per cycle
- Monitor power utilization and quality with ANSI C12.20 accuracy (0.2 percent)

- Verify meter accuracy with KYZ test pulse self-certification capabilities
- Optional 128KB for data logging which guards against loss of historical data
- Standard Modbus® RTU communications
- Available as transducer only or with display
- Field upgradeable to a Power Xpert® Meter 2000
- Integrate into Eaton's Power Xpert Architecture for a holistic system-level view

## Introduction

With energy costs skyrocketing, you need the ability to verify the accuracy of utility billing and allocation of energy costs among business units, different manufacturing areas or facilities, and tenants. Production equipment and IT systems are vulnerable to power anomalies; therefore you must ensure power is always up to specifications. If your infrastructure is an established facility, you may have addressed these concerns in the past by deploying a variety of analog gauges and meters — one for volts, one for amperes, and so on, with separate meters for each measurement. If you're planning an upgrade or new power infrastructure, no doubt you would like to capitalize on the latest technology to improve upon that cumbersome architecture and its patchwork view.

## High-end capabilities you would not expect from an ultra-compact meter

Providing the first line of defense against costly power problems, Eaton's IQ 250 and IQ 260 electronic power meters (IQ 250/260) can perform the work of an entire wall of legacy metering equipment utilizing today's technology. The IQ 250/260 meters use 24-bit A/D

converters that sample at more than 400 samples per cycle and meet ANSI C12.20 standards for accuracy of 0.2 percent. With such high-performance measurement capability, these meters can be confidently used for primary revenue metering and sub-metering applications.

Eaton's IQ 250/260 meters provide direct-reading metered values for the most critical power aspects, such as watts, watt demand, watt-hours, voltage-amperes (VA), VA-hours, vars, var-hours and power factor. They have high sampling speed and accuracy. The IQ 260 meter also measures power quality, such as total harmonic distortion (THD) up to the 40th order. The IQ 260 also provides configurable limit alarming/control capability of up to eight measured parameters for more sophisticated power management. In addition, the optional 128KB onboard storage protects against data loss in the event of a communication loss.

Is the utility company billing accurately? The IQ 250/260 provide a traceable KYZ watt-hour test pulse (used with a watt-hour pulse recorder or totalizer), so you can verify the accuracy of your meter, and in turn, the accuracy of billing from the utility company and to internal customers.

In addition, Eaton's IQ 250/260 meters provide flexible input/output options for access to future upgrades. The meters are also designed to integrate into Eaton's Power Xpert Architecture for end-to-end management of your entire power system, giving you a holistic system-level view. For example, using a Power Xpert Meter 2000 Gateway Card Kit, this meter can quickly and easily become a Power Xpert Meter 2000, which offers additional features such as Ethernet connectivity and emailing of alarms.



Powering Business Worldwide

## Features of IQ 250/260 Electronic Power meters

Features	IQ 250	IQ 260
<b>Instrumentation</b>		
Current, per phase	X	X
Current demand	X	X
Calculated neutral current	X	X
Voltage, per phase (L-L, L-N)	X	X
Frequency	X	X
<b>Power, energy &amp; demand</b>		
Real, reactive & apparent power, total & per phase (kW, kvar, kVA)	X	X
Real, reactive & apparent energy, total & per phase (kWh, kvarh, kVAh)	X	X
Real, reactive & apparent power demand	X	X
Power factor, total & per phase	X	X
Min./max. readings, I, V, PF, F, THD (IQ260), kW, kvar, kVA	X	X
<b>Demand methods</b>		
Block interval (sliding, fixed)	X	X
<b>Communications</b>		
RS-485	X	X
KYZ output	X	X
Modbus RTU	X	X
Modbus ASCII	X	X
DNP 3.0	X	X
<b>Data Logging</b>		
128KB for data logging	Opt.	Opt.
<b>I/O</b>		
2 digital in / 2 digital out <sup>1</sup>	Opt.	Opt.
4 digital in / 4 KYZ out	Opt.	Opt.
4 analog output (4 – 20 mA) <sup>2</sup>	Opt.	Opt.
4 analog output (0 – 1 mA)	Opt.	Opt.
<b>Power quality analysis</b>		
Total harmonic distortion (THD) voltage and current per phase		X
<b>Alarming</b>		
Set point driven alarm		X

<sup>1</sup> Digital out with the IQ 250 requires external command.

<sup>2</sup> Requires external power supply.



IQ 250/260 Meter (rear view) with connection and communication ports

## Mix-and-match input/output options

Perhaps you need to:

- Monitor the status of a piece of equipment
- Activate a warning light if voltage exceeds a certain threshold
- Trigger a relay contact-closure device
- Transmit power information directly to a process-control system or building management system, or to a legacy system that doesn't use Modbus

For any of these scenarios, IQ 250/260 meters provide optional input/output (I/O) cards that meet the need for either manual or automatic operation.

The IQ 250/260 meters provide flexible configuration, with four optional cards available (analog and digital), which can be combined in any fashion in two universal communication slots. The meters auto-detect the installed I/O modules, so you can easily add or change I/O cards after installation, giving you the ability to upgrade as needed.

## Industry-standard communication protocols

The IQ 250/260 meters use the open Modbus protocol. This industry-standard protocol provides serial communications with Eaton or third-party platforms, such as a building management system, power management system, or Eaton's Power Xpert Gateway for Web-based monitoring.

## Integrated with Eaton's Power Xpert Architecture

IQ 250/260 meters integrate into Eaton's Power Xpert Architecture, where meters, gateways and monitoring devices collaborate to create a unified, centralized view of the end-to-end power and facility's infrastructure.

When used in this architecture and in conjunction with Eaton's Power Xpert Gateway, IQ 260/260 meters can provide Web-based graphics of current power conditions. Simply connect your meter to a Power Xpert Gateway or upgrade to a Power Xpert Meter 2000 to translate Modbus-based information from the meter into HTML-based Web pages, accessible from any standard Web browser. With access to accurate, real-time information from IQ 250/260 meters, the Power Xpert Architecture can transform your power system into an integrated, agile system, an easily managed entity that performs better and costs less.

## Designed for the user

When space is at a premium, yet you need ANSI C12.20 accuracy, Eaton IQ 250/260 meters fit the bill. These ultra-compact meters are ideal for electrical equipment assemblies, machine control panels, such as panelboard and switchboard mains and feeders, low voltage metal-enclosed switchgear feeders and motor control centers. Requiring far less space than other meters with similar functionality, IQ 250/260 meters fit into a standard ANSI or IEC cutout on a panelboard or other electrical equipment, and therefore fit easily into retrofit applications.

Most meters in this class have small or dark displays that can be hard to see, especially from a distance. IQ 250/260 meters have a large, bright red, three-line LED display, each line more than a half-inch tall. This display is very easy to read, even if the meter is installed at a height or distance. Using the keypad and menus on the local display, users can display a variety of electrical system values or program the meter (see Figure 1). The IQ 250/260 meters can also be configured remotely using Eaton configuration software, provided with the meter.

In addition, the meters are available with or without the display module. You might choose to forego the display for applications where there is no need to configure or read the meter locally. This option reduces costs, especially where many meters will be monitored from a central operations system.



Figure 1 — IQ 250/260 Meter faceplate display

**IQ 250/260 Meter dimensions**

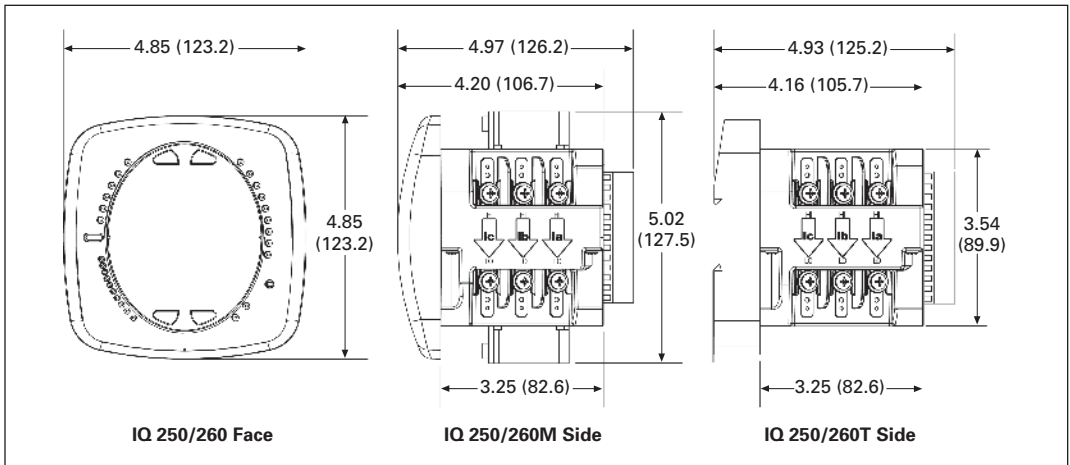

Expandable I/O componentry

IQ 250/260 Meter dimensions — face and side views

**IQ 250/260 Meter ordering information**

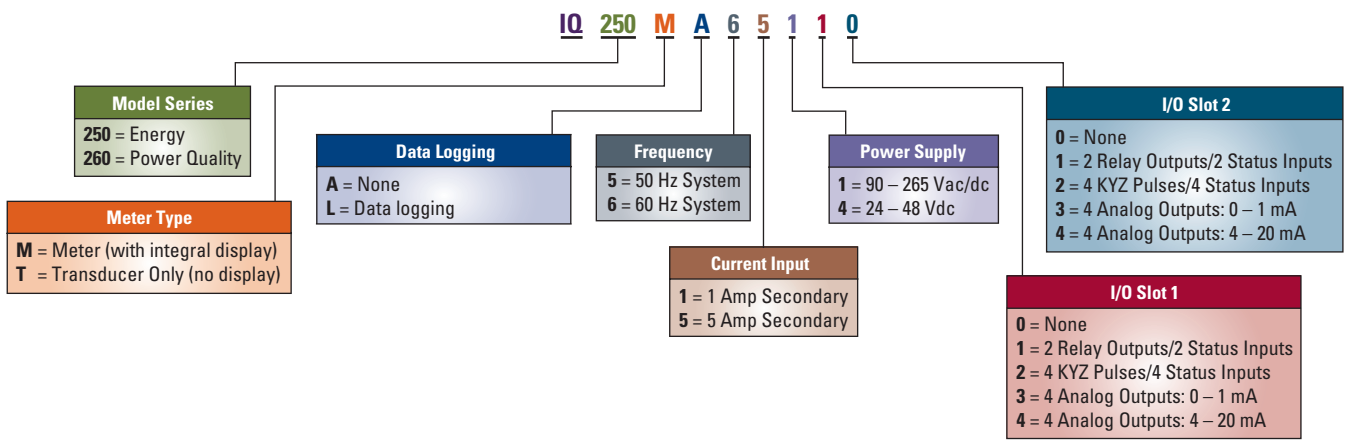

# IQ 250/260 Electronic Power Meter technical specifications

## Current inputs

Class 10	5 amp nominal, 10 amp max.
Class 2	1 amp nominal, 2 amp max.
Fault current withstand	
100 amps for:	10 seconds
300 amps for:	3 seconds
500 amps for:	1 second
Continuous current withstand	20 amps for screw terminated or pass-through connections
Programmable current	Full scale to any CT ratio
Burden	0.005 VA per phase max. at 11 amps
Pickup current	0.1% of nominal
Class 10	5 mA
Class 2	1 mA
Connections	
Pass-through wire gauge dimension	0.177 inches (4.5 mm)
Quick connect	0.25-inch male tab

## Voltage inputs

Range	
Line-to-neutral	20 – 576 Vac
Line-to-line	0 – 721 Vac
Programmable voltage range	Full scale to any PT ratio
Supported systems	3 element wye, 2.5 element wye, 2 element delta, 4-wire delta systems
Input impedance	1 meg ohm/phase
Burden	0.36 VA/phase max. at 600 V; 0.014 VA at 120 Volts
Connection	7-pin 0.400-inch pluggable terminal block, AWG #12 – 26 (0.129 – 3.31 mm <sup>2</sup> )

## Isolation

All inputs and outputs are galvanically isolated to 2500 volts.

## Environmental ratings

Operating temperature	-20°C to +70°C
Storage temperature	-20°C to +70°C
Operating humidity	To 95% RH non-condensing
Faceplate rating	NEMA® 12
	Water-resistant
	Mounting gasket included

## Sensing method

Voltage, current	True RMS
Power	Sampling at over 400 samples per cycle on all channels
Harmonics resolution	40th order

## Update rate

Watts, Var and VA	100 msec at 60 Hz
All other parameters	1 second at 60 Hz

## Power supply

AC/DC voltage option	90 – 265 Vac at 50/60 Hz or 100 – 370 Vdc, universal AC/DC supply
DC voltage option	18 – 60 Vdc
Burden	10 VA max.

## Standard communications format

Connection type	RS-485 (through back plate)
Com port baud rate	9600 – 57,600 bauds
Com port address	01 – 247
Data format	8-bit, no parity
Protocols	Modbus ASCII, RTU or DNP 3.0

## KYZ pulse

Contacts	1 form A
On resistance, max.	35 ohms
Peak switching voltage	350 Vdc
Continuous load current	120 mA
Peak load current	350 mA (10 ms)
Off-state leakage current at 350 Vdc	1 uA
Opto-isolation	3750 Vac

## Dimensions and shipping

Weight	2 lbs.
Basic unit	H 5.00 x W 4.90 x L 5.00 inches
IQ 250/260	Mounts in 92 mm DIN and ANSI C39.1 round cut-outs
Shipping container dimensions	6-inch cube
Tolerance	+/-0.1 inches (2.54 mm)

## Compliance

IEC 687	0.2% accuracy
ANSI C12.20	0.2% accuracy
ANSI C62.41	Burst
UL®/cUL®/CE	Electrical & electronic Measuring & test Equipment 22CZ

**Note:** Features and specifications listed in this document are subject to change without notice and represent the maximum capabilities of the software and products with all options installed. This is not a complete feature list. Features and functionality may vary depending on selected options.

**Eaton Corporation**  
Electrical Sector  
1111 Superior Ave.  
Cleveland, OH 44114  
United States  
877-ETN-CARE (877-386-2273)  
Eaton.com/meters

© 2011 Eaton Corporation  
All Rights Reserved  
Printed in USA  
PA02601007E / TN  
September 2011