



Cutler-Hammer

Motor Control Center Type F10 Unitrol

Renewal Parts

Supersedes RP.03A.01A.S.E
pages 1-24, dated September 2000

Description

Motor Control Center Type F10 Unitrol

	<i>Page</i>
Distributor Ordering Instructions	2
Procedure for Identifying MCC Renewal Units and Parts	2
Identifying Motor Control Center Types	3
Identification by Original Handle Mechanism	3
Procedure for Identifying Motor Control Center Types	3
F10 Unitrol Product Description	5
Replacement Starter Units	6 – 12
Unit Options	14 – 16
Structure Parts	17 – 19
Unit Parts	20 – 22
Series C® Retrofit Kits	23
Replacement Feeder Units (All Vintages)	26

MCC Type	Dates	Cutler-Hammer Renewal Parts Publication
F2100 Advantage™ Series 2100	1995 – 1992 – 1987 – 95	RP04304001E RP04304002E RP04304003E
5 Star Freedom Unitrol F10 Unitrol	1975 – 87 1988 – 94 1972 – 89	RP04304003E RP04304004E RP04304005E
Type W 9800 Unitrol 11-300	1965 – 75 1956 – 74 1935 – 65	RP04304006E RP04304007E RP04304008E

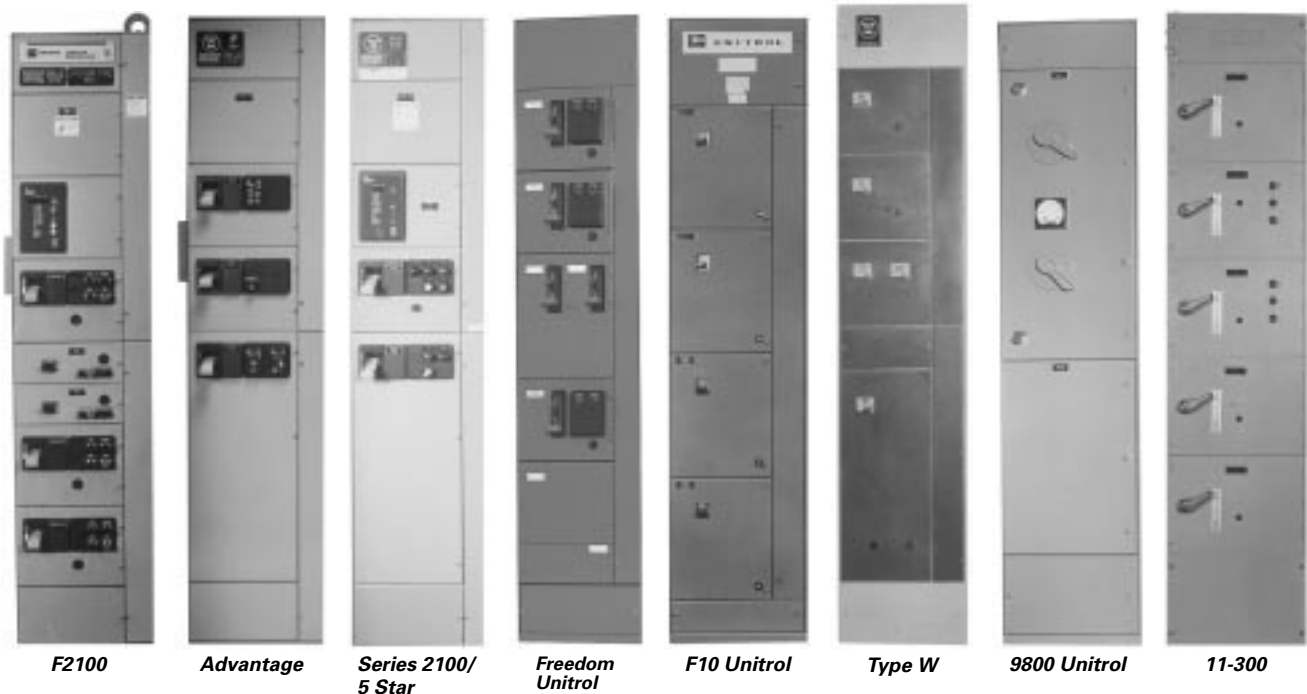

Identifying Motor Control Center Types

In most cases, it is possible to identify MCC design by handle type. Starter type, bucket width and door width can assist in identification.

Table 1. Identifying Motor Control Center Types

MCC Type	Type of Handle Mechanism	Original MCC Starter Type	Bucket Width Inches (mm)	Door Width Inches (mm)	Original Manufacturer ①	Starter Type (Installed in New Unit)
F2100 ②	Lever	Freedom Series	13-3/4 (349.3)	15-5/8 (397.0)	Cutler-Hammer 1994 to Present	Freedom
Advantage ②	Lever	Advantage	13-3/4 (349.3)	15-5/8 (397.0)	Westinghouse until 1994 Cutler-Hammer 1994 to Present	Advantage
Series 2100 ②	Lever	A200	13-3/4 (349.3)	15-5/8 (397.0)	Westinghouse until 1994 Cutler-Hammer 1994 to Present	A200
5 Star ②	Lever	A200	13-3/4 (349.3)	15-5/8 (397.0)	Westinghouse 1975 – 1987	A200
Freedom Unitrol	Slider	Freedom Series	13-7/8 (352.5)	15-1/2 (393.7)	Cutler-Hammer 1988 – 1994	Freedom
F10 Unitrol	Slider and Lever	Citation	14 (355.6)	14-3/4 (374.7) w/ Wireway 19-1/2 (495.3) w/o Wireway	Cutler-Hammer 1972 – 1989	Freedom
Type W	Slider	A200 or 11-200	11-3/4 (298.5)	13-3/8 (339.9)	Westinghouse 1965 – 1975	A200
9800 Unitrol	Rotary ③	3 Star/Citation	16-1/8 (409.7)	19-3/8 (492.3)	Cutler-Hammer 1956 – 1974	Freedom
11-300	Rotary	11-200 Lifeline Type N/A200	15-3/4 (400.1)	20 (508.0)	Westinghouse 1950 – 1965	A200

① MCC types were sometimes produced outside the time spans shown. This was due to the overlap of production when a new design was adopted.

② The unit “wrappers” are mechanically identical for these designs.

③ 9800 originally was supplied with Rotary. New replacement units are manufactured with slider handle mechanism.

Identification by Original Handle Mechanism



*F2100, Advantage,
Series 2100/5 Star*



Freedom Unitrol

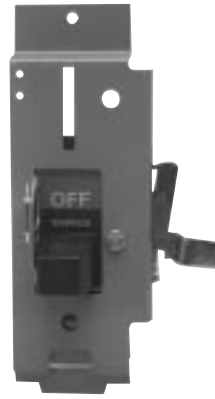

*F10 Unitrol Slider
9800 Unitrol*



*F10 Unitrol Lever
9800 Unitrol*



Type W



9800 Unitrol

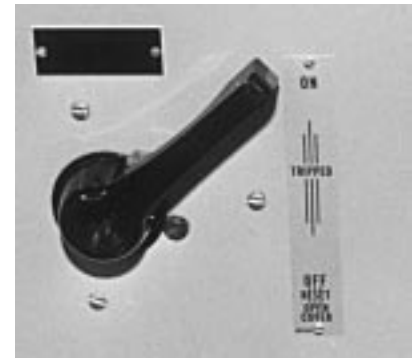

11-300

Procedure for Identifying Motor Control Center Types

In the event that the nameplate is missing, it is possible to identify the MCC design by the type of handle mechanism, starter type, bucket width and door width.

Table 2. Identifying Motor Control Center Types

MCC Type	Type of Handle Mechanism	Starter Type	Bucket Width Inches (mm)	Door Width Inches (mm)	Cutler-Hammer Renewal Parts Publication
F2100 Advantage Series 2100	Lever Lever Lever	Freedom Series Advantage A200	13-3/4 (349.3) 13-3/4 (349.3) 13-3/4 (349.3)	15-5/8 (397.0) 15-5/8 (397.0) 15-5/8 (397.0)	RP04304001E RP04304002E RP04304003E
5 Star Freedom Unitrol F10 Unitrol	Lever Slider Lever/Slider	A200 Freedom Series Citation	13-3/4 (349.3) 13-7/8 (352.5) 14 (355.6)	15-5/8 (397.0) 15-1/2 (393.7) 14-3/4 (374.7) w/ Wireway or 19-1/2 (495.3) w/o Wireway	RP04304003E RP04304004E RP04304005E
Type W 9800 Unitrol 11-300	Slider Rotary Rotary	A200 or 11-200 3 Star and/or Citation 11-200 Lifeline N and/or A200	11-3/4 (298.5) 16-1/8 (409.7) 15-3/4 (400.1)	13-3/8 (339.9) 19-3/8 (492.3) 20 (508.0)	RP04304006E RP04304007E RP04304008E



F2100

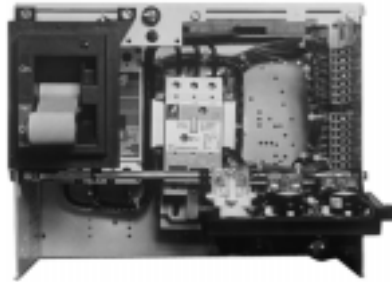

Advantage



Series 2100/5 Star

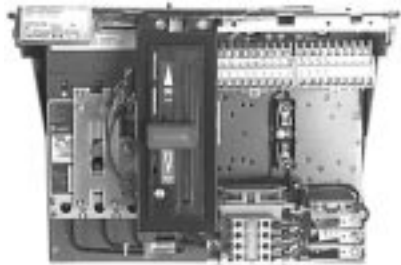

Freedom Unitrol

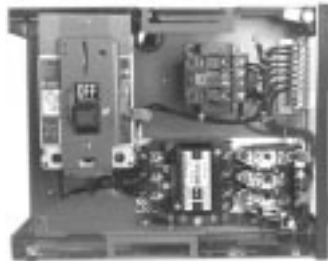

F10 Unitrol



Type W



9800 Unitrol



11-300

F10 Unitrol Product Description

Introduced in 1972, this Cutler-Hammer MCC was available in both 16 inches (406.4 mm) wide (with wireway) and 20 inches (508.0 mm) wide (without wireway). Bucket width is 14 inches (355.6 mm) and replacement units are available with both designs. Unit height is measured in 6-inch (152.4 mm) increments.

ANSI 49 was applied to the units, structural framework, roof, side sheets, and all exterior doors.

The F10 Unitrol MCC utilized the Citation starter and was identified by the slider type handle mechanism. Bus and bus support systems were typically braced to withstand fault currents of 42,000A.

Table 3. F10 Unitrol Product Rating

Maximum Ratings
3-Phase, 600V, 150 hp, 2000A Bus



**F10 Unitrol
Structure**

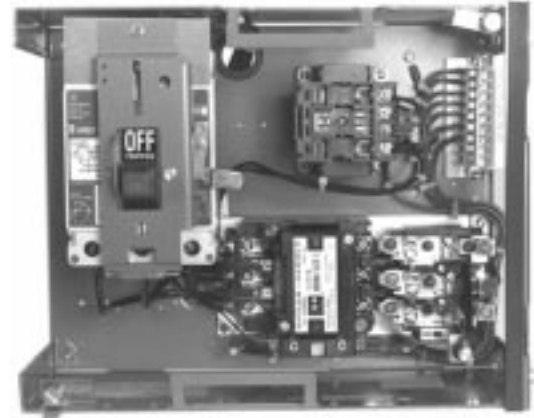

F10 Unitrol Starter Unit

F10 Unitrol Replacement Starter Units

How to Order

When ordering a replacement unit, you receive:

- Series C HMCP.
- Freedom Starter or Advantage Starter.
- Unit options as specified.
- New steel wrapper, door and handle mechanism.
- New stabs.
- UL® label.

Use the following steps for creating a catalog number for your specific application:

Step 1

Select the correct replacement unit from **Pages 6 – 13**. When selecting, you need to know the following:

- MCC type.
- Class of Unit (FVNR, FVR, Reduced Voltage — Autotransformer or Part Winding or Solid State, FV – 2 Speed, 1 Winding or 2 Speed, 2 Winding, etc.).
- Starter size or horsepower rating.
- Protection device (breaker or fusible).
- Service voltage.
- Control voltage.
- Space required.

Step 2

Verify required space is available.

Step 3

Create a catalog number by selecting Catalog Codes from the columns per the example given.

Step 4

Add modifications as required from the Unit Options on **Pages 14 – 16**. Space available determines allowable options.

Table 4. Catalog Numbering System Example

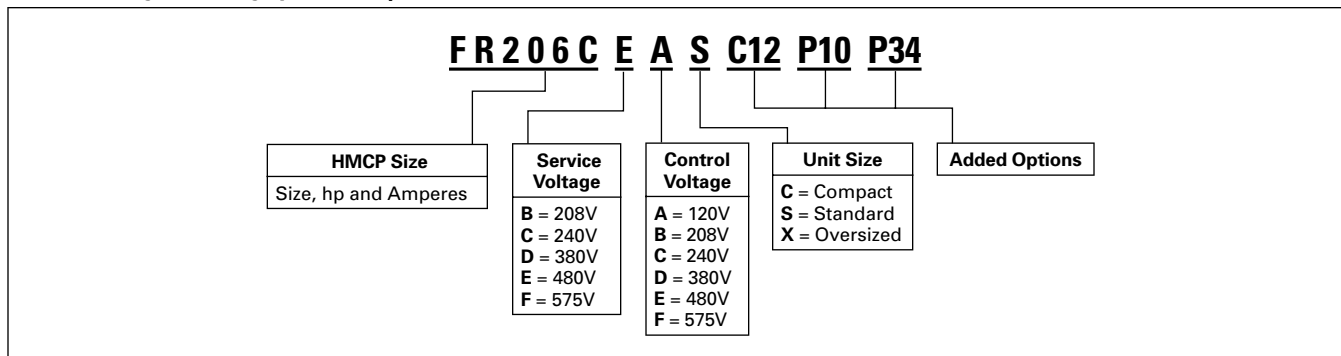

Table 5. Full Voltage Non-Reversing Combination Starter — HMCP

NEMA® Size	Maximum Horsepower					HMCP Size	Catalog Code	Service Voltage	Catalog Code	Control Voltage	Catalog Code	Space Options Inches (mm)	Catalog Code
	208V	240V	380V	480V	600V								
1	0.5	0.33	1	1	1.5	3 7 15 30	FR206A FR206B FR206C FR206D	208	B C D E F	120	A B C D E F	12 (304.8) High 18 (457.2) High	S X
	1	1	2	3	3			240		208			
	3	3	5	7.5	7.5			380		240			
	7.5	7.5	10	10	10			480		380			
								575		480			
2	10	15	25	25	15	50	FR206E	208	B C D E F	120	A B C D E F	12 (304.8) High 18 (457.2) High	S X
								240		208			
								380		240			
								480		380			
								575		480			
3	25	30	50	50	100	FR206H	208	B C D E F	120	A B C D E F	18 (457.2) High 24 (609.6) High	C S	
							240		208				
							380		240				
							480		380				
							575		480				
4	40	50	75	100	100	FR206L	208	B C D E F	120	A B C D E F	18 (457.2) High 24 (609.6) High	C S	
							240		208				
							380		240				
							480		380				
							575		480				
5	60	60	125	150	150	250 400	FR206P FR206R	208	B C D E F	120	A B C D E F	48 (1219.2) High	S ①
	75	100	150	200	200			240		208			
								380		240			
								480		380			
								575		480			

① NEMA Size 5 available. Cable in/Cable out unit supplied with full width door.

F10 Unitrol Replacement Starter Units

Table 6. Full Voltage Reversing Combination Starter — HMCP

NEMA Size	Maximum Horsepower					HMCP Size	Catalog Code	Service Voltage	Catalog Code	Control Voltage	Catalog Code	Space Options Inches (mm)	Catalog Code
	208V	240V	380V	480V	600V								
1	0.5	0.33	1	1	1.5	3	FR216A	208	B	120	A	18 (457.2) High	S
	1	1	2	3	3	7	FR216B	240	C	208	B		
	3	3	5	7.5	7.5	15	FR216C	380	D	240	C		
	7.5	7.5	10	10	10	30	FR216D	480	E	380	D		
								575	F	480	E		
							575	F	480	F			
2	10	15	25	25	25	50	FR216E	208	B	120	A	24 (609.6) High	S
								240	C	208	B		
								380	D	240	C		
								480	E	380	D		
								575	F	480	E		
								575	F	575	F		
3	25	30	50	50	50	100	FR216H	208	B	120	A	36 (914.4) High	S
								240	C	208	B		
								380	D	240	C		
								480	E	380	D		
								575	F	480	E		
								575	F	575	F		
4	40	50	75	100	100	150	FR216L	208	B	120	A	36 (914.4) High	S
								240	C	208	B		
								380	D	240	C		
								480	E	380	D		
								575	F	480	E		
								575	F	575	F		

Table 7. Full Voltage 2 Speed 1 Winding — Constant/Variable Torque — HMCP ①

NEMA Size	Maximum Horsepower					HMCP Size	Catalog Code	Service Voltage	Catalog Code	Control Voltage	Catalog Code	Space Options Inches (mm)	Catalog Code
	208V	240V	380V	480V	600V								
1	0.5	0.33	1	1	1.5	3	FR946A	208	B	120	A	24 (609.6) High	S
	1	1	2	3	3	7	FR946B	240	C	208	B		
	3	3	5	7.5	7.5	15	FR946C	380	D	240	C		
	7.5	7.5	10	10	10	30	FR946D	480	E	380	D		
								575	F	480	E		
							575	F	575	F			
2	10	15	25	25	25	50	FR946E	208	B	120	A	30 (762.0) High	S
								240	C	208	B		
								380	D	240	C		
								480	E	380	D		
								575	F	480	E		
								575	F	575	F		
3	25	30	50	50	50	100	FR946H	208	B	120	A	36 (914.4) High	S
								240	C	208	B		
								380	D	240	C		
								480	E	380	D		
								575	F	480	E		
								575	F	575	F		
4	40	50	75	100	100	150	FR946L	208	B	120	A	42 (1066.8) High	S
								240	C	208	B		
								380	D	240	C		
								480	E	380	D		
								575	F	480	E		
								575	F	575	F		

① For constant horsepower instead of constant/variable torque, see Option SV6 on Page 16.

F10 Unitrol Replacement Starter Units

Table 8. Full Voltage 2 Speed 2 Winding — Constant/Variable Torque — HMCP ①

NEMA Size	Maximum Horsepower					HMCP Size	Catalog Code	Service Voltage	Catalog Code	Control Voltage	Catalog Code	Space Options Inches (mm)	Catalog Code																												
	208V	240V	380V	480V	600V																																				
1	0.5	0.33	1	1	1.5	3	FR956A FR956B FR956C FR956D	208 240 380 480 575	B C D E F	120 208 240 380 480 575	A B C D E F	18 (457.2) High	S																												
	1	1	2	3	3									7																											
	3	3	5	7.5	7.5									15																											
	7.5	7.5	10	10	10									30																											
2	10	15	25	25	25	50	FR956E	208 240 380 480 575	B C D E F	120 208 240 380 480 575	A B C D E F	24 (609.6) High	S																												
														3	30	50	50	50	100	FR956H	208 240 380 480 575	B C D E F	120 208 240 380 480 575	A B C D E F	36 (914.4) High	S															
																											4	40	50	75	100	100	150	FR956L	208 240 380 480 575	B C D E F	120 208 240 380 480 575	A B C D E F	36 (914.4) High	S	
																																									1
2	20	25	40	40	40	100	FR706F	208 240 380 480 575	B C D E F	120 208 240 380 480 575	A B C D E F	24 (609.6) High	S																												
														3	40	50	75	75	75	150	FR706J	208 240 380 480 575	B C D E F	120 208 240 380 480 575	A B C D E F	30 (762.0) High															

① For constant horsepower instead of constant/variable torque, see Option SV6 on Page 16.

Table 9. Reduced Voltage Part Winding — HMCP

NEMA Size	Maximum Horsepower					HMCP Size	Catalog Code	Service Voltage	Catalog Code	Control Voltage	Catalog Code	Space Options Inches (mm)	Catalog Code																												
	208V	240V	380V	480V	600V																																				
1	10	10	15	15	15	30	FR706D	208 240 380 480 575	B C D E F	120 208 240 380 480 575	A B C D E F	18 (457.2) High	S																												
														2	20	25	40	40	40	100	FR706F	208 240 380 480 575	B C D E F	120 208 240 380 480 575	A B C D E F	24 (609.6) High	S														
																												3	40	50	75	75	75	150	FR706J	208 240 380 480 575	B C D E F	120 208 240 380 480 575	A B C D E F	30 (762.0) High	S

F10 Unitrol Replacement Starter Units

Table 10. Reduced Voltage Wye Delta Open Transition — HMCP ①

NEMA Size	Maximum Horsepower					HMCP Size	Catalog Code	Service Voltage	Catalog Code	Control Voltage	Catalog Code	Space Options Inches (mm)	Catalog Code
	208V	240V	380V	480V	600V								
2	20	25	40	40	40	100	FR806F	208 240 380 480 575	B C D E F	120 208 240 380 480 575	A B C D E F	24 (609.6) High	S
3	40	50	75	75	75	150	FR806J	208 240 380 480 575	B C D E F	120 208 240 380 480 575	A B C D E F	36 (914.4) High	S
4	60 —	75 —	125 150	150 —	150 —	250 400	FR806M FR806N	208 240 380 480 575	B C D E F	120 208 240 380 480 575	A B C D E F	48 (1219.2) High	S

① Size 4 Wye Delta starters use Molded Case Circuit Breakers.

Table 11. Reduced Voltage Wye Delta Closed Transition — HMCP (Non-Chiller Application)

NEMA Size	Maximum Horsepower					HMCP Size	Catalog Code	Service Voltage	Catalog Code	Control Voltage	Catalog Code	Space Options Inches (mm)	Catalog Code
	208V	240V	380V	480V	600V								
2	20	25	40	40	40	100	FR896F	208 240 380 480 575	B C D E F	120 208 240 380 480 575	A B C D E F	36 (914.4) High	S
3	40	50	50	50	50	100	FR896J	208 240 380 480 575	B C D E F	120 208 240 380 480 575	A B C D E F	48 (1219.2) High	S
4	60 —	75 —	125 150	150 —	150 —	250 400	FR896M FR896N	208 240 380 480 575	B C D E F	120 208 240 380 480 575	A B C D E F	60 (1524.0) High	S

F10 Unitrol Replacement Starter Units

IT06 — Intelligent Technologies *IT*. Solid-State Reduced Voltage Starter — HMCP

The *IT*. solid-state reduced voltage starter uses SCRs when starting and a low impedance run circuit during operation. Solid-state starters have (5) 24V dc inputs and 2 relay outputs. Soft start units include a disconnect, starter, 24V dc power supply and 100VA CPT.

Motor Service Factor (SF) Effect on *IT*. Starter Selection

- A 1.0 service factor motor may draw up to 1.00 x full load amperes.
- A 1.15 service factor motor may draw up to 1.15 x full load amperes.
- 15% more current. *IT*. starters are current rated devices. In some cases, a larger *IT*. SSRV starter must be supplied for 1.15 SF motors. See the maximum horsepower chart below.

Note: Most motors used in industrial applications are 1.15 Service Factor (SF).

Table 12. Replacement *IT*. Soft Start Units

Service Factor	Horsepower	<i>IT</i> . Soft-Start Amperes	HMCP Amperes	Catalog Code	Service Voltage	Catalog Code	Control Voltage	Catalog Code	Space Options Inches (mm)	Catalog Code
1.15	20	37	150	FR306A	480	E	120	A	18 (457.2) High	S
	40	66		FR306B			208	B		
	60	105	250	FR306C			240	C	30 (762.0) High	
	75	135	FR306D	380			D			
	125	180	400 ①	FR306E			480	E	48 (1219.2) High	
	150	240	FR306F	575			F			
	200	304	FR306G	—			—			

① No stab — unit cable in/cable out.

Table 13. Full Voltage Non-Reversing — Fusible ②

NEMA Size	Maximum Horsepower					Fuse Clip Amperes	Catalog Code	Service Voltage	Catalog Code	Control Voltage	Catalog Code	Space Options Inches (mm)	Catalog Code
	208V	240V	380V	480V	600V								
1	7.5	7.5	10	10	10	30	FR204C	208 240 380 480 575	B C D E F	120 208 240 380 480 575	A B C D E F	12 (304.8) High	S
2	— 10	— 15	15 25	15 25	25 —	30 60	FR204E FR204F	208 240 380 480 575	B C D E F	120 208 240 380 480 575	A B C D E F	18 (457.2) High	S
3	— 25	20 30	30 50	40 50	50 —	60 100	FR204H FR204J	208 240 380 480 575	B C D E F	120 208 240 380 480 575	A B C D E F	24 (609.6) High	S
4	— 50	— 50	— 60	60 100	75 100	100 200	FR204L FR204M	208 240 380 480 575	B C D E F	120 208 240 380 480 575	A B C D E F	36 (914.4) High	S

② Fuse clip ratings shown are based on Class RK1, 5 fuses.

F10 Unitrol Replacement Starter Units

Table 14. Full Voltage Reversing — Fusible ①

NEMA Size	Maximum Horsepower					Fuse Clip Amperes	Catalog Code	Service Voltage	Catalog Code	Control Voltage	Catalog Code	Space Options Inches (mm)	Catalog Code
	208V	240V	380V	480V	600V								
1	7.5	7.5	10	10	10	30	FR214C	208 240 380 480 575	B C D E F	120 208 240 380 480 575	A B C D E F	18 (457.2) High	S
2	— 10	— 15	15 25	15 25	25 —	30 60	FR214E FR214F	208 240 380 480 575	B C D E F	120 208 240 380 480 575	A B C D E F	24 (609.6) High	S
3	— 25	20 30	30 50	40 50	50 —	60 100	FR214H FR214J	208 240 380 480 575	B C D E F	120 208 240 380 480 575	A B C D E F	36 (914.4) High	S
4	— 50	— 50	— 60	60 100	75 100	100 200	FR214L FR214M	208 240 380 480 575	B C D E F	120 208 240 380 480 575	A B C D E F	42 (1066.8) High	S

① Fuse clip ratings shown are based on Class RK1, 5 fuses.

Table 15. Full Voltage 2 Speed 1 Winding — Fusible — Constant/Variable Torque ②③

NEMA Size	Maximum Horsepower					Fuse Clip Amperes	Catalog Code	Service Voltage	Catalog Code	Control Voltage	Catalog Code	Space Options Inches (mm)	Catalog Code
	208V	240V	380V	480V	600V								
1	7.5	7.5	10	10	10	30	FR944C	208 240 380 480 575	B C D E F	120 208 240 380 480 575	A B C D E F	24 (609.6) High	S
2	— 10	— 15	15 25	15 25	25 —	30 60	FR944E FR944F	208 240 380 480 575	B C D E F	120 208 240 380 480 575	A B C D E F	30 (762.0) High	S
3	— 25	20 30	30 50	40 50	50 —	60 100	FR944H FR944J	208 240 380 480 575	B C D E F	120 208 240 380 480 575	A B C D E F	42 (1066.8) High	S
4	— 50	— 50	— 60	60 100	75 100	100 200	FR944L FR944M	208 240 380 480 575	B C D E F	120 208 240 380 480 575	A B C D E F	48 (1219.2) High	S

② Fuse clip ratings shown are based on Class RK1, 5 fuses.

③ For constant horsepower instead of constant/variable torque, see Option SV6 on Page 16.

F10 Unitrol Replacement Starter Units

Table 16. Full Voltage 2 Speed 2 Winding — Fusible — Constant/Variable Torque ①②

NEMA Size	Maximum Horsepower					Fuse Clip Amperes	Catalog Code	Service Voltage	Catalog Code	Control Voltage	Catalog Code	Space Options Inches (mm)	Catalog Code
	208V	240V	380V	480V	600V								
1	7.5	7.5	10	10	10	30	FR954C	208 240 380 480 575	B C D E F	120 208 240 380 480 575	A B C D E F	18 (457.2) High	S
2	— 15	— 15	15 25	15 25	25 —	30 60	FR954E FR954F	208 240 380 480 575	B C D E F	120 208 240 380 480 575	A B C D E F	24 (609.6) High	S
3	— 25	20 30	30 50	40 50	50 —	60 100	FR954H FR954J	208 240 380 480 575	B C D E F	120 208 240 380 480 575	A B C D E F	36 (914.4) High	S
4	— 50	— 50	— 60	60 100	75 100	100 200	FR954L FR954M	208 240 380 480 575	B C D E F	120 208 240 380 480 575	A B C D E F	42 (1066.8) High	S

① Fuse clip ratings shown are based on Class RK1, 5 fuses.

② For constant horsepower instead of constant/variable torque, see Option SV6 on Page 16.

Table 17. Reduced Voltage Part Winding — Fusible ③

NEMA Size	Maximum Horsepower					Fuse Clip Amperes	Catalog Code	Service Voltage	Catalog Code	Control Voltage	Catalog Code	Space Options Inches (mm)	Catalog Code
	208V	240V	380V	480V	600V								
1	10	10	15	15	15	60	FR704D	208 240 380 480 575	B C D E F	120 208 240 380 480 575	A B C D E F	18 (457.2) High	S
2	— 20	15 25	25 40	30 40	40 —	60 100	FR704F FR704G	208 240 380 480 575	B C D E F	120 208 240 380 480 575	A B C D E F	30 (762.0) High	S
3	— 40	— 50	— 75	50 75	60 75	100 200	FR704J FR704K	208 240 380 480 575	B C D E F	120 208 240 380 480 575	A B C D E F	42 (1066.8) High	S

③ Fuse clip ratings shown are based on Class RK1, 5 fuses.

F10 Unitrol Replacement Starter Units

Table 18. Reduced Voltage Wye Delta Open Transition — Fusible ①

NEMA Size	Maximum Horsepower					Fuse Clip Amperes	Catalog Code	Service Voltage	Catalog Code	Control Voltage	Catalog Code	Space Options Inches (mm)	Catalog Code
	208V	240V	380V	480V	600V								
2	15	15	30	40	40	60 100	FR804F FR804G	208 240 380 480 575	B C D E F	120 208 240 380 480 575	A B C D E F	30 (762.0) High	S
	20	25	40	—	—								
3	25	30	50	60	75	100 200	FR804J FR804K	208 240 380 480 575	B C D E F	120 208 240 380 480 575	A B C D E F	42 (1066.8) High	S
	40	50	75	75	—								
4	50	60	100	125	150	200 400	FR804M FR804N	208 240 380 480 575	B C D E F	120 208 240 380 480 575	A B C D E F	60 (1524.0) High	S
	60	75	150	150	—								

① Fuse clip ratings shown are based on Class RK1, 5 fuses.

Table 19. Reduced Voltage Wye Delta Closed Transition — Fusible ②

NEMA Size	Maximum Horsepower					Fuse Clip Amperes	Catalog Code	Service Voltage	Catalog Code	Control Voltage	Catalog Code	Space Options Inches (mm)	Catalog Code
	208V	240V	380V	480V	600V								
2	15	15	30	40	40	60 100	FR894F FR894G	208 240 380 480 575	B C D E F	120 208 240 380 480 575	A B C D E F	36 (914.4) High	S
	20	25	40	—	—								
3	25	30	50	60	75	100 200	FR894J FR894K	208 240 380 480 575	B C D E F	120 208 240 380 480 575	A B C D E F	48 (1219.2) High	S
	40	50	75	75	—								

② Fuse clip ratings shown are based on Class RK1, 5 fuses.

Table 20. Adjustable Frequency Drive Units

<p><i>Consult Factory for Price and Availability</i></p>
--

F10 Unitrol Unit Options

Table 21. Option Groups ①

Groups	Description	Page Number
A	Advantage Options	14
B	Circuit Breaker Options	14
C	Control Power Source Options	14
G	Ground Fault Protection Options	14
M	Metering Options	15
O	Overload Options	15
P	Pilot Device Options	15
R	Relay and Timer (Control, Voltage, Current) Options	16
S	Starter Contact Options	16
SV	Vacuum Starter Options	16
T	Terminal Block Options	16
U	Unit Wiring Options	16

① Select your option suffix and attach it to the end of the catalog number.

Table 22. Option Suffix

Suffix	Description	Space Required ②
--------	-------------	------------------

A — Advantage Options

A10	Substitute Advantage Starter Size 1	③
A11	Substitute Advantage Starter Size 2	③
A12	Substitute Advantage Starter Size 3	③
A13	Substitute Advantage Starter Size 4	③
A14	Substitute Advantage Starter Size 5	C ③④
A15	Advantage Hand/Off/Auto ACM for FVNR or RVNR Starters	C ④
A16	Advantage Stop/Start for FVNR or RVNR Starters	C ④
A17	Advantage Hand/Off/Auto-Start/Stop ACM for FVNR or RVNR Starters	C ④
A18	Advantage Fast/Slow/Stop 2-Speed Starters	C ④
A19	Advantage Forward/Reverse/Stop for Reversing Starters	C ④
A20	Advantage Fast/Slow/Off/Auto for 2-Speed Starters	C ④
A21	Advantage Forward/Reverse/Off/Auto for Reversing Starters	C ④
A22	ACM Metering Module	C ④
A23	WBELL Form C Bell Alarm Contact	C ④
A24	Reset with Overload Alarm and Trip Indication	C ④
A25	120V ac PLC Circuit Compatible Load Resistor	C ④
A26	WPONI PowerNet Communications Module	C ④
A27	Advantage Status Only ACM	C ④
A28	WPONIDNA DeviceNet Communications Module	C ④

B — Breaker Options

B10	Shunt Trip 120V AC Wired to Terminal Blocks for Remote Tripping	C
B11	Auxiliary Switch Form C (1NO/1NC) Wired to Terminal Blocks	C
B12	Form C Bell Alarm Contact (1NO/1NC) Wired to Terminal Blocks	C
B13	Undervoltage Release	C
B14	IQ Energy Sentinel — F Frame	③
B15	IQ Energy Sentinel — J Frame	③
B16	IQ Energy Sentinel — K Frame	③
B17	IQ Central Energy Display	③
B18	Thermal Magnetic Circuit Breaker Instead of HMCP	—

C — Control Power Source Options

C10	Control Fuse Wired for Separate Source in Lieu of Control Power Transformer	C
C11	Control Fuse with Disconnect for Separate Source in Lieu of Control Power Transformer	C
C12	Control Power Transformer 100 VA for Size 1 and 2 Starters (Fused)	C ④
C13	Control Power Transformer 150 VA for Size 3 and 4 Starters (Fused)	C
C14	Control Power Transformer 100 VA with Interposing Relay for Size 5 Starters, Fused	C
C15	Extra 50 VA for Control Power Transformer	S
C16	Extra 100 VA for Control Power Transformer	S
C17	Service Voltage Control, Fused in Lieu of Control Power Transformer	C
C18	Full Capacity Control Power Transformer for Size 5 Starters, Fused	C

G — Ground Fault Protection Options

G10	Class 1 Ground Fault Protection — GRT1 Size 1 – 4	X
G11	Class 1 Ground Protection — GRT1 Size 5 – 6	X
G12	Ground Fault Test Panel	X

② Minimum unit size required (refer to Replacement Unit pages).

③ Consult factory for spacing.

④ Not available in 6 inches (152.4 mm).

F10 Unitrol Unit Options

Table 22. Option Suffix (Continued)

Suffix	Description	Space Required ^①
M — Metering Options		
M10	Mini Voltmeter	C ^②
M11	Mini Ammeter with Current Transformer	S
M12	Mini Elapsed Time Meter	C ^②
M13	Current Transformer for Remote Metering	S
M14	Current Transducer 4-20 mA Output	X
O — Overload Options		
O10	IQ 500 Solid-State Overload Relay	—
O11	IQ 500 Load Protection Module	—
O16	Bell Alarm Contact (1NO) Wired	C
O17	Bi-Metallic Overload Substitution	C
O18	Adjustable A200 Overload Substitution	C
O19	Overload Relay Heater/Heater Pack	C
O20	CEP7 Solid-State Overload Relay	C
P — Pilot Device Options ^③		
P10	Red "RUN" Light	C
P11	Green "STOPPED" Light	C
P12	Amber "OVERLOAD TRIPPED" Light	C
P13	Green "RUN" Light	C
P14	Red "STOPPED" Light	C
P15	Red "RUN" Push-to-Test Light	C
P16	Green "STOPPED" Push-to-Test Light	C
P17	Amber "OVERLOAD TRIPPED" Push-to-Test Light	C
P18	Green "RUN" Push-to-Test Light	C
P19	Red "STOPPED" Push-to-Test Light	C
P20	Special Function Light	C
P30	"START" Pushbutton	C
P31	"STOP" Pushbutton	C
P32	"START/STOP" Pushbutton	C
P33	"ON" Pushbutton	C
P34	"OFF" Pushbutton	C
P35	"ON/OFF" Pushbutton	C
P36	"FORWARD/REVERSE/STOP" Pushbutton	C
P37	"FAST/SLOW/STOP" Pushbutton	C
P38	"FAST/OFF/SLOW" Pushbutton	C
P39	"HIGH/LOW/STOP" Pushbutton	C
P40	"HIGH/LOW/OFF" Pushbutton	C
P41	Special Function Pushbutton	C
P50	"ON-OFF" Selector Switch	C
P51	"HIGH-LOW" Selector Switch	C
P52	"OFF-AUTO" Selector Switch	C
P53	"START-STOP" Selector Switch	C
P54	"SLOW-FAST" Selector Switch	C
P55	"FORWARD-REVERSE" Selector Switch	C
P56	Special Function 2-Position Selector Switch	C
P57	"HAND-OFF-AUTO" Selector Switch	C
P58	"LOCAL-OFF-REMOTE" Selector Switch	C
P59	"FAST-OFF-SLOW" Selector Switch	C
P60	"HIGH-OFF-LOW" Selector Switch	C
P61	Special Function 3-Position Selector Switch	C
P62	"HIGH-LOW-OFF-AUTO" Selector Switch	C
P63	Special Function 4-Position Selector Switch	C

^① Minimum unit size required (refer to Replacement Unit pages).

^② Customer to supply range of meter required.

^③ Available only with F2100, Advantage, Series 2100/5 Star, Freedom Unitrol, F10 Unitrol and Type W. Consult factory for specific size limitations.

F10 Unitrol Unit Options

Table 22. Option Suffix (Continued)

Suffix	Description	Space Required ^①						
R — Relay and Timer Options								
R10	Auxiliary Control Relay 2-Pole (1NO/1NC) Convertible Contacts Wired in Parallel with Starter Coil	S						
R11	Auxiliary Control Relay 4-Pole (2NO/2NC) Convertible Contacts Wired in Parallel with Starter Coil	S						
R12	Auxiliary Control Relay 2-Pole Overload Alarm (1NO/1NC) Convertible Contacts	S						
R13	Mechanical Latching Relay (Specify Connection)	X						
R14	Ice Cube Relay 300 Volts 3-Pole Blade Type (Specify Connection)	S						
R15	Phase Voltage Relay	X						
R16	Current Sensing Relay with Contacts Wired to Terminal Blocks	X						
R17	Deceleration Timing Relay (Pneumatic "OFF" Delay)	S						
R18	Compelling Timing Relay (Pneumatic "ON" Delay)	S						
R19	Time Clock 24 Hour	②						
R20	Time Clock 7 Day	②						
R21	Solid-State Timer Type TR (Specify Connection)	S						
R22	DN65 DeviceNet Interface Module	S						
R23	D15 2-Pole Control Relay	C						
R24	D15 4-Pole Control Relay	C						
S — Starter Contact Options (Maximum of 8 Contacts)								
S__	To order extra starter contacts, you must specify the number of NO/NC contacts, given a maximum of eight (8). To define the unit option required, create a suffix based on the following example:							
	<table border="1" style="margin-left: 40px;"> <thead> <tr> <th></th> <th>Quantity of Normally Open Contacts</th> <th>Quantity of Normally Closed Contacts</th> </tr> </thead> <tbody> <tr> <td>S</td> <td>2</td> <td>3</td> </tr> </tbody> </table>		Quantity of Normally Open Contacts	Quantity of Normally Closed Contacts	S	2	3	
	Quantity of Normally Open Contacts	Quantity of Normally Closed Contacts						
S	2	3						
SV — Vacuum Starter Options								
SV4	Vacuum Starter Size 4 Substitution FVNR	②						
SV5	Vacuum Starter Size 5 Substitution FVNR	②						
SV6	Constant Horsepower Instead of Constant/Variable Torque	—						
T — Terminal Block Options								
T10	Pull-apart Type Terminal Blocks (Standard on all Vintages Except Type W and 11-300)	S						
T11	Utility Screw Type Terminal Blocks (Add 6 Inches (152.4 mm) for Every 18 Points)	—						
T12	Front-mounted Pull-apart Terminal Block for F2100, Advantage, Series 2100/5 Star	S						
T13	T-Lead Power Terminal Blocks for Size 1 Starter	—						
U — Unit Wiring Options								
U10	Surge Suppressor on Coil	C						
U11	Type SIS Control Wire	C						
U12	Type SIS Power Wire	C						
U13	Type 14 Gauge Control Wire (Standard for all Vintages Except F2100, Series 2100/5 Star, Type W and 11-300)	C						
U14	Wiremarkers — Sleeve Type on all Control Wire	C						
U15	Locking Fork Terminals on all Control Wiring	S						
U16	Ring Wire Terminals on Power Wiring	S						
U17	Wiring Diagram Inside Starter Unit Door	C						
U18	Pre-insulated Ring Terminals on all Control Wiring	C						
U19	Pre-insulated Ring Terminals on all Control Wiring, except for Freedom Starter Terminals	C						
U20	Wiremarkers for Power Wiring	C						

① Minimum unit size required (refer to Replacement Unit pages).

② Consult factory for spacing.

F10 Unitrol Structure Parts

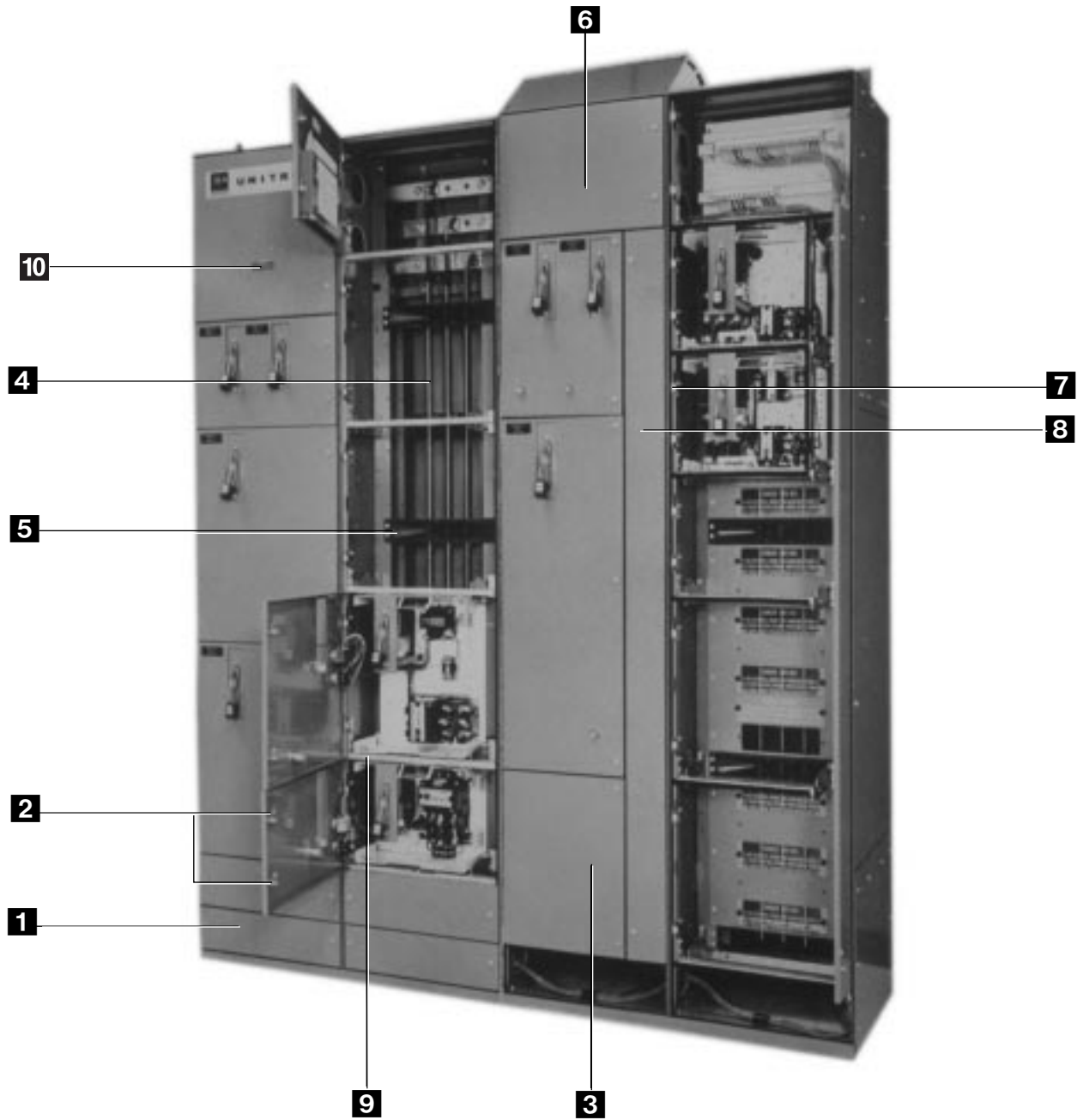

Table 23. Structure Parts

Reference	Description	Page
1	Bottom Front Plate	18
2	Door Mounting Hardware Kit	18
3	Blank Unit Door Kit	18
4	Vertical Bus Unit Support Bracket	18 18
5	Vertical Bus Support	19

Reference	Description	Page
6	Top Front Plate	18
7	Vertical Door Strip	19
8	Vertical Wireway Door	19
9	Horizontal Cross Channel	18
10	Filler Plate	18

F10 Unitrol Structure Parts

Top Front Plate

Table 24. Top Front Plate

Dimensions in Inches (mm)		Style Number
Height	Width	
7 (177.8)	20 (508.0)	47-19428
7 (177.8)	30 (762.0)	47-19428-2
13 (330.2)	20 (508.0)	47-19430
13 (330.2)	30 (762.0)	47-19430-2
19 (482.6)	20 (508.0)	47-19432
19 (482.6)	30 (762.0)	47-19432-2

Bottom Front Plate

Table 25. Bottom Front Plate

Dimensions in Inches (mm)		Style Number
Height	Width	
5 (127.0)	20 (508.0)	47-32150
11 (279.0)	20 (508.0)	47-32151
5 (127.0)	30 (762.0)	47-32150-2
11 (279.0)	30 (762.0)	47-32151-2

Vertical Bus

Table 26. Vertical Bus

Description	Style Number
600A Silver Plated Copper A Phase Bus Bar	25-3002-7

Must be shortened for use in sections with 11-inch (279.4 mm) bottom plates and any B and C phase bus.

Horizontal Cross Channel

Table 27. Horizontal Cross Channel

Description	Style Number
Channel with Wireway	47-19406
Channel without Wireway	47-19405

Unit Support Bracket

Table 28. Unit Support Bracket

Description	Style Number
Left-Hand Side	79-9532
Right Hand with Wireway	79-9530
Right Hand without Wireway	79-9530-2

6-Inch (152.4 mm) Filler Plate

Table 29. 6-Inch (152.4 mm) Filler Plate

Description	Style Number
20-Inch (508.0 mm) Wide Plate	47-20348
15-Inch (381.0 mm) Wide Plate	47-20348-2

Door Mounting Hardware Kit



Door Mounting Hardware Kit

Table 30. Door Mounting Hardware Kit

Description	Style Number
Kit includes (2) 1/4 turn latches, 2 hinges, clip and label.	3A73618G01

Blank Unit Door Kit

Table 31. Blank Unit Door Kit

Dimensions in Inches (mm)		Style Number
Height	Width	
Standard Width		
6 (152.4)	14-3/4 (374.7)	3A73618G09
12 (304.8)	14-3/4 (374.7)	3A73618G10
18 (457.2)	14-3/4 (374.7)	3A73618G11
24 (609.6)	14-3/4 (374.7)	3A73618G12
30 (762.0)	14-3/4 (374.7)	3A73618G13
36 (914.4)	14-3/4 (374.7)	3A73618G14
42 (1066.8)	14-3/4 (374.7)	3A73618G15
48 (1219.2)	14-3/4 (374.7)	3A73618G16
54 (1371.6)	14-3/4 (374.7)	3A73618G17
60 (1524.0)	14-3/4 (374.7)	3A73618G18
66 (1676.4)	14-3/4 (374.7)	3A73618G19
72 (1828.8)	14-3/4 (374.7)	3A73618G20
Full Width		
6 (152.4)	19-7/8 (505.0)	47-20348
12 (304.8)	19-7/8 (505.0)	47-20340-2
18 (457.2)	19-7/8 (505.0)	47-20341-2

Note: Kit includes door, hinges, 1/4 turn latches and clips.

F10 Unitrol Structure Parts

Vertical Bus Support 5



Vertical Bus Support

Table 32. Vertical Bus Support

Description	Style Number
Vertical Bus Support	79-8268-2

Vertical Wireway Door 8



Vertical Wireway Door

Table 33. Vertical Wireway Door

Dimensions in Inches (mm)		Style Number
Height	Width	
12 (304.8)	4-1/4 (108.0)	47-30638
18 (457.2)	4-1/4 (108.0)	47-30638-3
24 (609.6)	4-1/4 (108.0)	47-30638-5
30 (762.0)	4-1/4 (108.0)	47-30638-7
36 (914.4)	4-1/4 (108.0)	47-30638-9
42 (1066.8)	4-1/4 (108.0)	47-30638-11
48 (1219.2)	4-1/4 (108.0)	47-30638-13
54 (1371.6)	4-1/4 (108.0)	47-30638-15
60 (1524.0)	4-1/4 (108.0)	47-19464
66 (1676.4)	4-1/4 (108.0)	47-19464-2
72 (1828.8)	4-1/4 (108.0)	47-19464-3

Vertical Door Strip 7



Vertical Door Strip

Table 34. Vertical Door Strip

Dimensions in Inches (mm)	Style Number
6 (152.4)	79-10633-8
12 (304.8)	79-10633
18 (457.2)	79-10633-2
24 (609.6)	79-16812
30 (762.0)	79-16812-2
36 (914.4)	79-16812-3
42 (1066.8)	79-16812-4
48 (1219.2)	79-16812-5

F10 Unitrol Unit Parts

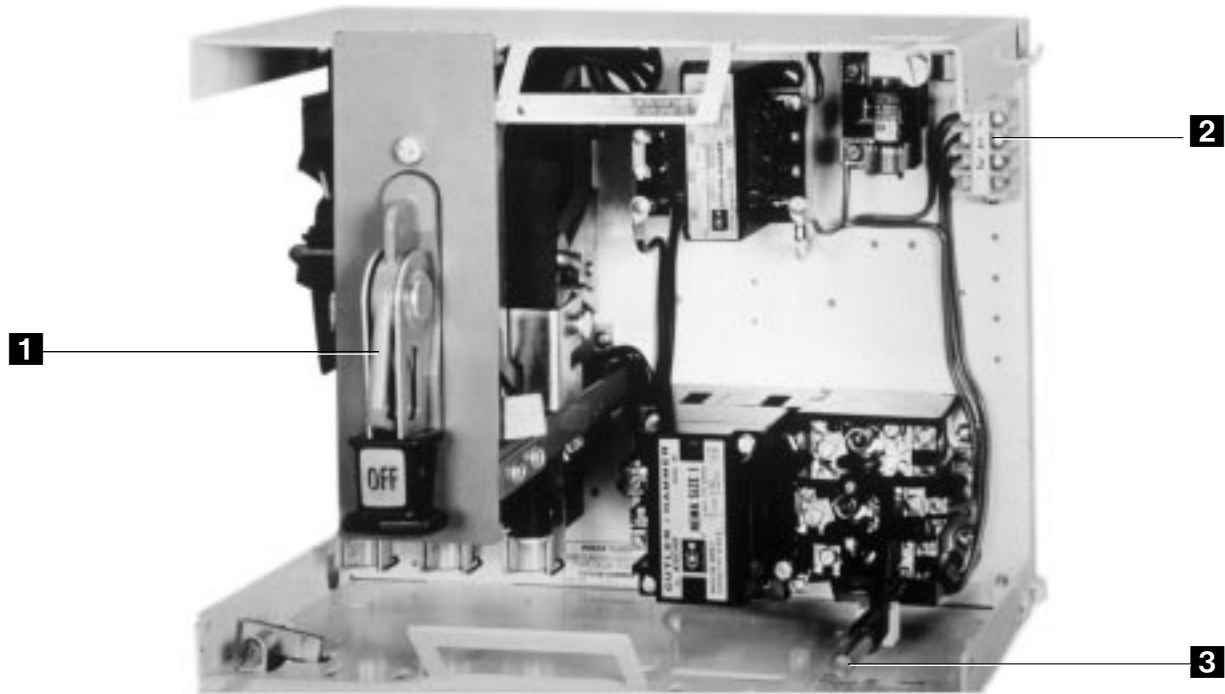

Table 35. Unit Parts

Reference	Description	Page
1	Operating Handle Mechanism Kit	21
	Disconnect Switch for Fusible Devices	21
	Load Side Fuse Base	21
	Fuse Clip Kit	21

Reference	Description	Page
2	Terminal Blocks	22
3	Overload Reset Button and Reset Rod	22
	External Operator Interlocks	22
	Unit Mounting Hardware Kit	21

F10 Unitrol Unit Parts

Operating Handle Mechanism Kit 1



Operating Handle Mechanism Kit

Table 36. Operating Handle Mechanism Kit

Description	Style Number
-------------	--------------

Slider Type for Circuit Breaker

HMCP, FS or FB (150A Frame)	10-7175-5 ①
JD (250A Frame)	10-7176-2
KB, KD or KS (400A Frame)	10-7176-3

Lever Type for Circuit Breaker

Obsolete — Consult Factory	—
----------------------------	---

Lever Type for Fusible Switch

Obsolete — Consult Factory	—
----------------------------	---

① Include brackets to mount handle mechanism.

Note: Kit includes handle mechanism with mounting hardware.

Unit Mounting Hardware Kit 2



Unit Mounting Hardware Kit

Table 37. Unit Mounting Hardware Kit

Description	Style Number
Kit includes left and right support brackets and horizontal cross channel.	3A73618G08

Disconnect Switch for Fusible Devices 1



Disconnect Switch for Fusible Devices

Obsolete — Consult Factory

Load Side Fuse Base 1

Obsolete — Consult Factory

Fuse Clip Kit 1

Table 38. Fuse Clip Kit

Description	Amperes	Style Number
Kit includes one set of fuse clips.	30	3A73618G04
	60	3A73618G05
	100	3A73618G06
	200	3A73618G07

F10 Unitrol Unit Parts

External Operator Interlocks



External Operator Interlocks

Table 39. External Operator Interlocks

Description	Style Number
Lever	
1 NO/1 NC	10-5355-2
2 NO/2 NC	10-5355-3
Slider	
1 NO/1 NC	10-5355
2 NO/2 NC	10-5355-5

Overload Reset Button and Reset Rod Extension Kit



Overload Reset Button and Reset Rod Extension Kit

Table 40. Overload Reset Button and Reset Rod Extension Kit

Description	Style Number
For sizes 1 – 4, the kit includes reset button, retainer, reset rod, and adapter.	3A73618G03

Terminal Blocks

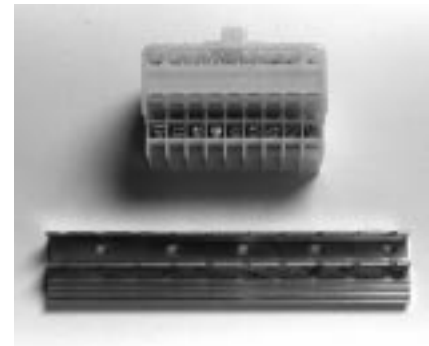

Terminal Blocks

Table 41. Terminal Blocks

Description	Style Number
Terminal Blocks with mounting bracket.	3A73618G02

Series C® Retrofit Kits

Series C Retrofit Kits are to be used to upgrade existing Type W and 5 Star Motor Control Center buckets by changing out the old breakers with the Series C. These kits can be applied to both starter and feeder units.

The old breakers that these kits will upgrade include, but are not limited to, the MCP, F, FA, FB, HFB, K, KA, KB, HKB, L, LA, LB and HLB breakers.

5 Star Series C Retrofit Kit



5 Star Series C Retrofit Kit

The 5 Star Series C Retrofit Kit includes:

- Series C device, 65 kA (either HMCP or thermal-magnetic breaker).
- Operating handle mechanism, including tripped indication and push-to-trip.
- Label stating that the MCC unit has been retrofitted with Series C device suitable for 65 kA (similar to UL quality label).
- Templates for desired frame size.
- Assembly instructions.

Type W Series C Retrofit Kit

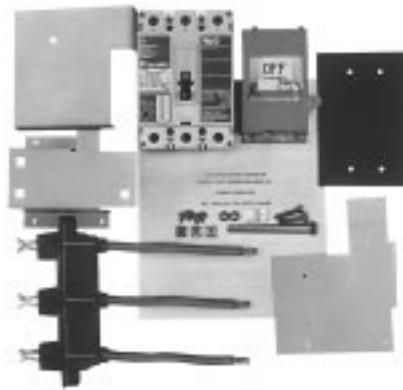

Type W Series C Retrofit Kit

The Type W Series C Retrofit Kit includes:

- Series C device, 65 kA (either HMCP or thermal-magnetic breaker).
- Operating handle mechanism, including tripped indication and push-to-trip.
- Label stating that the MCC unit has been retrofitted with Series C device suitable for 65 kA (similar to UL quality label).
- Templates for proper hole placement for desired frame size.
- Series C breaker mounting hardware.
- New door and hardware.
- New stab assembly.
- Assembly instructions.

F10 Series C Retrofit Kit



F10 Series C Retrofit Kit

The F10 Series C Retrofit Kit includes:

- Series C device, 65 kA (either HMCP or thermal-magnetic breaker).
- Operating handle mechanism, including tripped indication and push-to-trip.
- Label stating that the MCC unit has been retrofitted with Series C device suitable for 65 kA (similar to UL quality label).
- Templates for desired frame size.
- Assembly instructions.

How to Order

1. Select the correct Series C device from the table in the applicable RPD
 5 Star — RP04304003E
 Type W — RP04304006E
 F10 — RP04304005E
2. Create a catalog number based on the MCC Type, Device Selected, Modification, Door Size and Device Panel.

Select price from PL04304002E.

Table 42. Series C Retrofits, Catalog Numbering System

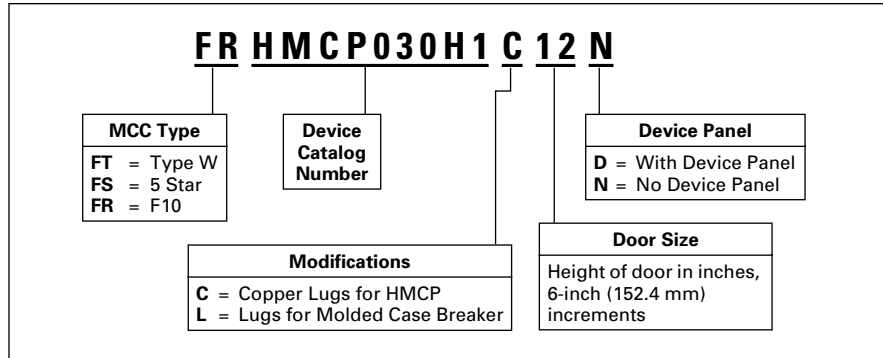

Table 43. Series 2100/5-Star Series C Breaker Retrofit Upgrade Kit

Catalog Number	Catalog Number	Catalog Number	Catalog Number	Catalog Number
FRHMCP003A0	FRHMCP250D5	FRHFD3020	FRFDC3030	FRJDC3200
FRHMCP007C0	FRHMCP250F5	FRHFD3025	FRFDC3040	FRJDC3225
FRHMCP015E0	FRHMCP250G5	FRHFD3030	FRFDC3050	FRJDC3250
FRHMCP025D0	FRHMCP250J5	FRHFD3040	FRFDC3060	—
FRHMCP030H1	FRHMCP250K5	FRHFD3050	FRFDC3070	—
FRHMCP050G2	FRHMCP250L5	FRHFD3060	FRFDC3080	—
FRHMCP050K2	FRHMCP250W5	FRHFD3070	FRFDC3090	—
FRHMCP070J2	FRHMCP400G5	FRHFD3080	FRFDC3100	—
FRHMCP070M2	FRHMCP400J5	FRHFD3090	FRFDC3125	—
FRHMCP100L3	FRHMCP400K5	FRHFD3100	FRFDC3150	—
FRHMCP100R3	FRHMCP400L5	FRHFD3125	FRHJD3175	—
FRHMCP150T4	FRHMCP400W5	FRHFD3150	FRHJD3200	—
FRHMCP150U4	FRHMCP400R5	FRFDC3015	FRHJD3225	—
FRHMCP250A5	FRHMCP400X5	FRFDC3020	FRHJD3250	—
FRHMCP250C5	FRHFD3015	FRFDC3025	FRJDC3175	—

Note: Entire catalog number is not listed above and will not affect price.

How to Create a Catalog Number

After selecting the circuit device required, create a Dual Mounted feeder unit catalog number based on the following:

Note: Catalog number varies in length based on single or dual mounted unit.

Table 44. Catalog Numbering System Example

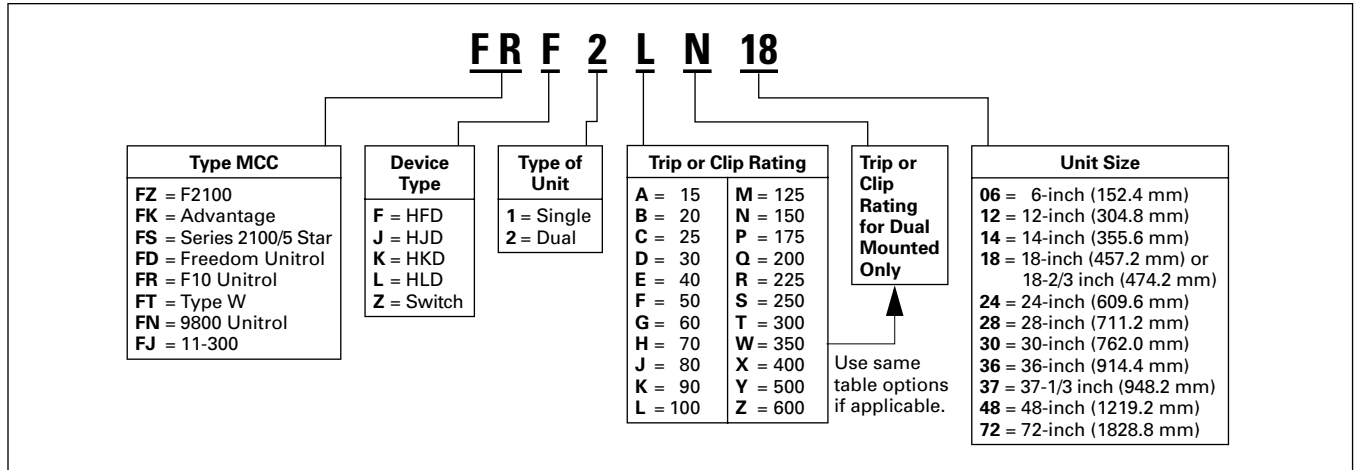

Replacement Feeder Units

Product Description

Each Feeder Unit consists of a single-mounted 3-pole molded case circuit breaker or fusible switch (dual mounted are also available). Each unit includes a new wrapper, stab assembly, door, handle mechanism and customer specific disconnect device. They are shipped assembled and ready to install into the existing motor control center.

The following are simple steps to select and order a new feeder unit:

Step 1

Select the circuit device required from **Table 45** below.

Step 2

Verify the amount of space available.

Step 3

Create a catalog number using **Table 44** on **Page 25**.

Unit options and modifications for replacement feeder units:

For factory installed molded case circuit breaker modifications or additional unit options, contact the factory for prices and availability.

Table 45. Electrical Characteristics and Space Requirements of Molded Case Circuit Breakers and Fusible Switch Replacement Feeder Units — Inches (mm)

Device Type	Maximum Amperes	Interrupting Rating (kAIC)			Trip Rating or Clip	Freedom 2100 Series 2100/5 Star Advantage		Freedom Unitrol		F10		Type W		9800		11-300						
		240V	480V	600V		Single	Dual	Single	Dual ^①	Single	Dual ^①	Single	Dual	Single	Dual ^①	Single	Dual					
HFD	150	100	65	25	15																	
					20																	
					25																	
					30																	
					40																	
					50																	
					60																	
					70																	
					80	6 ^② (152.4)		6 ^② (152.4)														
					90	12 ^③ (304.8)	12 (304.8)	12 ^③ (304.8)	12 (304.8)	12 ^③ (304.8)	12 (304.8)	12 ^③ (304.8)	12 (304.8)	14 (355.6)	14 (355.6)	14 (355.6)	14 (355.6)					
					100																	
					125	12 (304.8)	12 (304.8)	12 (304.8)	18 (457.2)	12 (304.8)	18 (457.2)	12 (304.8)	12 (304.8)	14 (355.6)	18 (457.2)	14 (355.6)	14 (355.6)					
					150	12 ^③ (304.8)						12 ^③ (304.8)										
HJD	250	100	65	25	175																	
					200																	
					225	18 (457.2)		24 (609.6)		18 (457.2)		18 (457.2)		18 (457.2)		18 (457.2)		14 (355.6)				
				250																		
HKD	400	100	65	35	300																	
					350																	
					400	24 (609.6)		24 ^④ (609.6)		24 ^④ (609.6)		24 (609.6)		28 ^④ (711.2)		14 (355.6)						
HLD	600	100	65	35	500																	
					600	24 (609.6)		24 ^④ (609.6)		24 ^④ (609.6)												
Fusible Switch	30	100	100	100	30	12 (304.8)	12 ^③ (304.8)	12 (304.8)	18 (457.2)	12 (304.8)	18 (457.2)	12 (304.8)	12 ^③ (304.8)	14 (355.6)	18 (457.2)	14 (355.6)	14 (355.6)					
	60	100	100	100	60	12 (304.8)	12 ^③ (304.8)	12 (304.8)	18 (457.2)	18 (457.2)	18 (457.2)	12 (304.8)	12 ^③ (304.8)	14 (355.6)	18 (457.2)	14 (355.6)	14 (355.6)					
	100	100	100	100	100	18 (457.2)		18 (457.2)		18 (457.2)		12 ^③ (304.8)		18 (457.2)		18 (457.2)	18-2/3 (474.2)					
	200	100	100	100	200	36 (914.4)		30 (762.0)		30 (762.0)		24 (609.6)		28 (711.2)		28 (711.2)						
	400	100	100	100	400	36 (914.4)		72 ^④ (1828.8)		48 ^④ (1219.2)		42 (1066.8)		42 ^④ (1066.8)		42 (1066.8)						
	600	100	100	100	600	48 (1219.2)		72 ^④ (1828.8)														

① Combined ampacity no greater than 150A for 12-inch (304.8 mm) height. For greater than 150A, 18-inch (457.2 mm) required.

② 100A maximum.

③ Available in 18-inch (457.2 mm) height.

④ Cable in/cable out, no stab assembly.

NEMA is the registered trademark and service mark of the National Electrical Manufacturers Association. UL is a registered trademark of Underwriters Laboratories Inc.

Eaton Corporation
Cutler-Hammer business unit
1000 Cherrington Parkway
Moon Township, PA 15108-4312
USA
tel: 1-800-525-2000
www.cutler-hammer.eaton.com

