

Control & Apparatus
PowerPlus™ Panelboards

PowerPlus™ Panelboards

Lighting, heat tracing and power panels



Crouse-Hinds
by **EAT•N**



PowerPlus™ Panelboards

designed, engineered and manufactured to be the industry's safest and most dependable panelboard for hazardous area locations.



Design Features

TYPE 4X BREATHER AND DRAIN STANDARD

- Corrosion-resistant Type 4X breather and drain comes standard with all PowerPlus panelboards, permitting all models to maintain their Type 4 (Type 4X with suffix S752) rating while utilizing a breather/drain solution to drain internal condensation while protecting against ingress of rain and hose water

SILVER-PLATED COPPER BUSS SYSTEM

- PowerPlus panels come standard with a high quality silver-plated copper buss system, which provides high efficiency current flow between the main feed and branch breakers

LOCKOUT/TAGOUT CAPABILITY

- Each branch and main breaker handle is provided with lockout/tagout capability, which complies with OSHA lockout/tagout requirements for safety
- Allows for locking in the ON or OFF position for standard maintenance checks

SPRING LOADED, QUICK RELEASE COVER BOLTS

- Spring loaded, quick release, captive stainless steel cover bolts come standard to prevent damage to the flat joint flame path when opening and closing the cover, while providing visual identification of bolt engagement

HINGED STAINLESS STEEL ICE/DUST SHIELD

- PowerPlus panels are available with an optional hinged stainless steel ice/dust shield
- Ice shield solution prevents ice and snow build-up on breaker handles to allow for proper handle function in cold/wet climate applications

STAINLESS STEEL HINGES

- Stainless steel hinges are engineered to provide maximum stability and allow the cover to swing fully open
- Avoids misalignment of cover to the body of the enclosure and prevents the cover from obstructing interior access

GFI AND EPD BREAKERS AVAILABLE

- PowerPlus D2L and EPL panels are available with GFI and/or EPD breakers
- 21-position electrical test circuit allows for testing of GFI, EPD or a combination of both in one panel
- EPLDN panels are available with up to 42 GFI or EPD circuits with 225 amp main breaker



*Note: D2D/EXD panels are not available with GFI or EPD circuit breakers or electrical test circuit as standard. Please contact factory if required.

INTEGRATED STEEL LIFTING EYE

- Integrated steel lifting eye is mounted on the top side of each PowerPlus panel
- Provides a stable lifting position to ensure ease of mounting during the installation process



**D2LBS (Inverted) or
D2DBS (Inverted)**

†Not available in size F offering. Spring aligning forks are standard on size F panels.

‡EPL*A and EXD*A conduit entries 2" or larger in Class I, Division 1 must be sealed within 18" of enclosure. All alternate feed entries to breaker housing (suffix A) must have an external seal within 18" of enclosure.

EXTERNAL FLANGE DESIGN

- PowerPlus cast enclosures are manufactured with an external flange design
- Design allows for a wide unobstructed cover opening and provides a completely accessible interior for ease of maintenance and wiring

SELF-ALIGNING BREAKER OPERATORS

- Superior self-aligning breaker operators are designed for both field and factory installation
- Patented design guarantees proper handle alignment when closing the cover†

FACTORY SEALED

- All panels with terminal housings are factory sealed‡ and fully wired for maximum available circuits
- Allows PowerPlus models the ability to have additional breakers field installed while maintaining their factory seal

FULLY WIRED TERMINAL BLOCKS

- All terminal blocks come fully wired with each contact numbered for easy connecting of branch entries

REMOVABLE GLAND PLATES

- Heavy gauge 316L stainless steel terminal housings are supplied with three removable gland plates to be used with Myers™ Hubs
- Design allows for the flexibility of factory or field drilled openings for hubs

HIGH INTEGRITY GASKET

- Stainless steel terminal housings offer a high integrity gasket, providing a watertight seal to meet enclosure Type 4/CSA Enc. 4/IP65 requirements
- Provides superior protection of enclosed wiring against water and corrosion
- Cast aluminum enclosures are also gasketed, providing a NEMA 4 watertight seal

316L STAINLESS STEEL TERMINAL HOUSING

- PowerPlus panelboards offer an industrial grade 316L stainless steel terminal housing as standard
- Design offers an increased internal volume with a removable front cover for easy access during field installation and maintenance
- A cast aluminum terminal housing is standard on EPL and EXD panels and available on D2L and D2D panels

Specifications

PowerPlus factory sealed panelboards are premium panelboards that provide maximum circuit flexibility with labor savings during installation, operation and maintenance, and are accommodating for future changes in the field (order with either 'S' or 'A' in base catalog number). Panels are pre-wired to maximum circuit capacity, allowing for easy and safe replacement or installation of components in the field, while maintaining factory sealed integrity.

PowerPlus non-factory sealed panelboards are value panelboards that offer maximum circuit flexibility and many of the same features of the PowerPlus premium line. This value solution is provided without terminal housing and factory wiring of circuits (order with 'N' in base catalog number). The non-factory sealed solution reduces initial panelboard material costs and requires field wiring to circuit breakers and external seals to be field installed during installation.

Applications:

- Areas made hazardous by the continuous or abnormal presence of flammable gases, vapors and combustible dusts
- Areas subject to weather, dampness and corrosion
- For branch power distribution and circuit protection to motors, valves, pumps, lighting, heat tracing, receptacles, etc.
- For indoor and outdoor applications in petroleum refineries, chemical and petrochemical plants and other process industry facilities where similar hazards exist
- To accommodate up to 100 amp branch loads (only 3 circuits); balance is up to 50 amps

Certifications and Compliances:

EXD & EPL Series (Division 1):

- NEC/CEC:
 - Class I, Division 1 & 2, Groups B†, C, D
 - Class I, Zone 1 & 2, IIB + H₂†
 - Class II, Division 1, Groups E, F, G
 - Class II, Division 2, Groups F, G
 - Class III
- NEMA/EEMAC: 3, 4, 4X*, 7B†CD, 9EFG, 12
- CSA Enc. 3, 4, 5
- UL Standard: 67, 1203
- cUL (to CSA Standard C22 Nos. 29 & 30)
- IP65

D2D & D2L Series (Division 2):

- NEC/CEC:
 - Class I, Division 2, Groups B†, C, D
 - Class I, Zone 2, IIB + H₂†
 - Class II, Division 2, Groups F, G
 - Class III
- NEMA/EEMAC: 3, 4, 4X*, 7B†CD, 12
- CSA Enc. 3, 4, 5
- UL Standard: 67, 1203
- cUL (to CSA Standard C22.2 Nos. 29 & 30)
- IP65

Standard Materials and Finishes:

- Circuit breaker enclosure body and cover – copper-free aluminum
- Terminal housing – Type 316L stainless steel ('S') or copper-free aluminum ('A')

Incoming Lug Terminals	Panel Size B, C, D	D2D/EXD Size F
Line (A, B, C) wire range	4-4/0	6-350MCM
Branch circuit (1, 3, 5) wire range	10-0	10-0
Branch circuit (balance) wire range	24-8	18-4
Neutral line wire range	6-350MCM	6-250MCM
Neutral circuit wire range	14-4	14-1/0
Ground line wire range	6-350MCM	6-250MCM
Ground circuit wire range	14-4	14-1/0

- Gasket – neoprene (cast aluminum enclosure); foam-in-place (stainless steel enclosure)
- Operating handles – copper-free aluminum
- Operating shafts and bushings, cover bolts, washers, hinges, breather/drain, retractile springs – stainless steel
- Circuit breaker operators – D2D/EXD size F: copper-free aluminum; all other types: non-metallic
- Lifting bracket – electrogalvanized cold rolled steel
- Chassis – silver-plated copper
- Breather cap – Delrin® non-metallic material
- Neutral and ground bar – tin-plated aluminum



D2DDS

†Group B and IIB + H₂ is standard on all PowerPlus panels, but requires special brackets to be installed on breakers to ensure long-term operability of circuit breakers. To order with brackets installed at factory, add suffix GB. For field installable kit, order EPL-GB-KIT for D2L/EPL or EXD-GB-KIT for D2D/EXD sizes B, C and D separately.

*NEMA 4X rating is available when ordered with suffix S752 or S753.

Delrin® is a registered trademark of DuPont.

Electrical Ratings

D2D/EXD Series:

Branch Breakers Trip Ratings

Panel Size	Voltage	Phase/Wire	Main Breaker Amperage	Branch Breaker
B	480Y/277	3P 4W	Up to 100	G-frame
	480Δ ¹	3P 3W	Up to 100	G-frame
C	480Y/277	3P 4W	Up to 100	G-frame
	480Δ ¹	3P 3W	Up to 100	G-frame
D	480Y/277	3P 4W	Up to 225	G-frame
	480Δ ¹	3P 3W	Up to 225	G-frame
F	480Y/277, 480Δ or 600Δ ¹	3P 3W or 3P 4W	Up to 225	F-frame

Panel Sizes B, C and D (GHB Series Cutler-Hammer™)

- 1, 2 and 3 pole: GHB 480/277Y (standard offering)
- 2 and 3 pole: GDB 480Δ (requires suffix GDB)
- 1, 2 and 3 pole: GBH 600Y/347 (requires suffix GBH; contact factory)
- 15, 20, 25, 30, 35, 40, 45, 50 amp (available in all breaker spaces in panel); 60, 70, 80, 90, 100 amp (only 3 breaker spaces available)³
- Ambient compensated breakers are optional to +50°C (suffix V)

Panel Size F (F-frame breaker: EHD Cutler-Hammer standard)

- 15, 20, 25, 30, 35, 40, 45, 50, 60, 70 amp (available in all breaker spaces in panel); 80, 90, 100 amp (only 3 breaker spaces available)
- Breaker types available² (refer to Options section to specify breaker type)
 - FDB: 2 and 3 pole 600V
 - FD: 1, 2 (277V) and 3 pole (600V)
 - HFD: 1, 2 (277V) and 3 pole (600V)
 - EHD: 1, 2 (277V) and 3 pole (480V)

Main Breaker Trip Ratings

- 2 and 3 pole (contact factory for single phase sizes B, C, D)
- Size B, C: 15 to 100 amps
- Size D, F: 15 to 225 amps

Main Lugs

- Size B, C, F: 225 amps
- Size D: not available; main breaker only

Ampere Interrupting Capacity

- All size panels are certified to 10kAIC
- Breaker AIC ratings:
 - GHB breaker: 14kAIC at 480Y/277
 - EHD breaker: 14kAIC at 480V

Breaker types optional with sizes B, C and D panel only:

- GDB breaker: 14kAIC at 480V

Breaker types optional with size F panel only:

- FDB breaker: 14kAIC at 480V and 600V
- FD breaker: 18kAIC at 600V and 35kAIC at 480V and 277V
- HFD breaker: 25kAIC at 600V and 65kAIC at 480V and 277V

D2L/EPL Series:

Branch Breakers (120/240 VAC BAB Series Quicklag® Bolt-on) Trip Ratings

- 1, 2 and 3 pole
- 10, 15, 20, 25, 30, 35, 40, 45, 50 amp (available in all breaker spaces in panel); 55, 60, 70, 80, 90, 100 amp (only 3 breaker spaces available for 55 to 100 amp branch breakers)
- GFI type, 1 and 2 pole (5mA sensitivity) 15, 20, 25, 30, 40 (50 amp - available with 2 pole only)
- EPD type, 1 and 2 pole (30mA sensitivity) 15, 20, 25, 30, 40 (50 amp - available with 2 pole only)
- HID type, 1 and 2 pole, 15, 20, 25, 30, 35, 40, 50, 60
- Available with GFI, EPD or a combination of both in one panel with a 21-position electrical test circuit
- Ambient compensated breakers available to +50°C

Main Breaker Trip Ratings

- 2 or 3 pole
- Size B: 10 to 100 amps
- Size C, D: 10 to 225 amps

Main Lugs

- Size B, C, F: 225 amps
- Size D: not available; main breaker only



¹ For 480Δ 3P 3W system or for 600 VAC, a suffix is required. See page 8 for suffix options. For 480Δ system, please contact factory. Note: for single pole 480Δ, GHB breakers will be furnished for sizes B, C and D.

² F-frame breakers are only available in size F panel with up to a maximum of 30 circuit spaces.

³ 2 pole GDB breakers are only available up to 50 amps.

Accessories & Options

Accessories:

Field installable gland plates with factory-provided aluminum Myers Hubs for the D2L and D2D stainless steel terminal housing (one 3 inch hub and 12 branch entry hubs - size dependent upon suffix, each kit includes 3 gland plates, 1 for the top or bottom and 1 for each side):

	D2L	D2D
¾" Branch entry hub	D2L HUB2 KIT	D2D HUB2 KIT
1" Branch entry hub	D2L HUB3 KIT	D2D HUB3 KIT
1-½" Branch entry hub	D2L HUB5 KIT	D2D HUB5 KIT
Replacement gland plate (no hubs)	D2L HUB0 KIT	D2D HUB0 KIT

Circuit Breaker Operator Assemblies

Operator Assemblies	Part Number
D2L/EPL 1 pole or 3 pole breakers	EPL HDL13
D2L/EPL 2 pole breakers	EPL HDL2
D2D/EXD all breakers panel sizes B, C, D	EXD HDL123
D2D/EXD all breakers panel size F	EXD K1

Replacement cover plugs for both D2L/EPL and D2D/EXD for unused circuit breaker positions (qty. 5):

Plug Kits	Part Number
D2L/EPL sizes B, C, D	EPL OP PLG
D2D/EXD sizes B, C, D	EXD OP PLG
D2D/EXD size F	EXD K2

Kit for Group B, standard panels less GB suffix are suitable for Group B, but it is required to install brackets on breakers. To order brackets factory installed, add suffix GB. For field installable kit, order:

- D2L/EPL kit: **EPL GB KIT**
- D2D/EXD sizes B, C, D kit: **EXD GB KIT**

D2L/EPL stainless steel breaker operator cover to protect operators from ice build-up for all D2L/EPL PowerPlus Panels. For D2D/EXD styles, please contact factory.

- Kit for size B panel: **EPL HG24 KIT**
- Kit for sizes C and D panel: **EPL HG42 KIT**

Space heater kits:

- D2L/EPL: **EPL R22 KIT**
- D2D/EXD: **EXD R44 KIT**

Terminal housing mounting plate kit to adapt depth of terminal housing to same depth as breaker enclosure:

Panel Types/Sizes	Part Number	Terminal Housing
D2L/EPL sizes B, C, D	EPLA MTG KIT ⁴	Aluminum
D2D/EXD sizes B, C, D	EXDA MTG KIT ⁴	Aluminum
D2L sizes B, C, D	D2LS MTG KIT ⁴	Stainless
D2D sizes B, C, D	D2DS MTG KIT ⁴	Stainless

Options:

To add the following features to the panelboard, add a space and then the suffix to the catalog number. Multiple suffixes should be added in alpha-numeric order.

Space heater (D2L/EPL).....	R22
Space heater (D2D/EXD)	R44
Square head plugs on all conduit openings ⁵	SP
Epoxy powder coat finish, external	S752
Epoxy powder coat finish, internal and external.....	S753
Recess head plugs on all conduit openings ⁵	RP
Stainless steel breaker operator cover (ice shield)	HG
Group B kit factory installed	GB
GFI breakers ⁶	G
EPD breakers ^{6,7}	E
HID breakers ⁶	H
Ambient compensated breakers (+50°C)	V
GDB 480Δ 3P 3W system ⁸	GDB
FDB 600V breakers ⁹	FDB600
FD 600V breakers ⁹	FD600
HFD 600V breakers ⁹	HFD600
Lamacoid nameplate	LID

A standard panelboard has conduit openings for power and branch circuits on top.

- To order a panelboard with main power feed from the bottom of breaker housing, and branch entries on top (alternate), add **A**¹⁰
- To order an inverted panelboard with all conduit openings for power and branch circuits on the bottom (inverted), add..... **I**
- To order an inverted panelboard with main power feed on top and bottom (alternate inverted), add..... **A-I**¹⁰

⁴ The weight of the panel is sufficiently supported by mounting of breaker enclosure.

⁵ Not available on stainless terminal housings.

⁶ Available with D2L and EPL panels only. For D2D/EXD, please contact factory.

⁷ Single pole 480V EPD available. For all others, please contact factory. Two breaker positions for single pole EPD: odds start at position 1; evens start at position 4.

⁸ Available in D2D and EXD sizes B, C and D only.

⁹ Available with D2D and EXD size F panels only.

¹⁰ Not available in D2L/EPL size D panels. D2D/EXD sizes C and D are only available with up to 36 circuits.

Breaker Spaces Tables

Table A. Maximum Number of Breaker Spaces

D2L/EPL Panels

Panel Size	Maximum Number of Branch Circuit Breaker Spaces			Available Main Breaker Ampacity	Available with GFI, EPD Branch Protection
	With Main Lug Only	With Main Breaker			
		Two Pole	Three Pole		
B	24	22	21	Up to 100 ¹²	Yes
C ¹¹	42	40	39	Up to 100 ¹²	Yes
		36	36	110 to 225 ¹³	Yes
D	42	42	42	Up to 225 ¹³	Yes

Table B. Maximum Number of Breaker Spaces

D2D/EXD Panels

Panel Size	Maximum Number of Branch Circuit Breaker Spaces			Available Main Breaker Ampacity	Available with GFI, EPD Branch Protection ¹⁴
	With Main Lug Only	With Main Breaker			
		Two Pole	Three Pole		
B	24	22	21	Up to 100 ¹²	No
C	42	40	39	Up to 100 ¹²	No
D	N/A	42	42	Up to 225 ¹³	No
F	30	30	30	Up to 225 ¹³	No

Table C. To Size Panels with GFI or EPD Branch Breakers

Maximum Number of GFI or EPD Breakers		
Panel Size	With Main Lug or Main Breaker	With Main Breaker
	Single Pole	Two Pole
B	21	12 (10 with 3 pole MCB, 11 with 2 pole MCB)
C	21	14

Each factory sealed panel is equipped with 42 load wires for GFI/EPD breakers and any combination with standard branch breakers. Determine the total number of load wires required to complete your panel. You may not exceed 42 load wires.

Load Wires Required	
Single pole breaker	= 1
Single pole GFI (or EPD) breaker	= 2
Two pole breaker	= 2
Two pole GFI (or EPD) breaker	= 3
Three pole breaker	= 3

Maximum Total: 42 load wires (factory sealed)

EPLDN Panels

Maximum Total: 82 load wires (non-factory sealed)

D	EPLDN only - can go up to 42 GFI or EPD circuits. EPLDN will accommodate up to 225 amp main breaker.
---	--

¹¹ All size B and C panels with main breaker rated up to 100 amps use a back-fed branch breaker. All size C and D panels with main breaker rated from 110 amps to 225 amps have a dedicated location for main breaker. Size C ordered with suffix 2M00 or 3M00 are provided with 36 branch circuits for maximum breaker ampacity.

¹² Main breakers are chassis mounted and back fed.

¹³ Main breakers are mounted external to chassis.

¹⁴ GFI, EPD for D2D/EXD are not standard options. If required, please contact factory.

Ordering Information

D2L/EPL Series

Example: **D2LCS330G*28120*01115G-3M225-GB**

Class I, Division 2/Zone 2, Group B panel with:

- 240 VAC lighting panelboard
- 28 single pole 20 amp branch breakers
- 1 single pole 15 amp GFI breaker
- 225 amp 3 pole main circuit breaker

D2L

Panel Type

D2L Div. 2/Zone 2

EPL Div. 1 & 2/
Zone 1 & 2

C

Enclosure Size

B 24 circuit panel

C 42 circuit panel (36 circuit panel
with main breaker greater than
100 amps)

D 42 circuit panel

Terminal Enclosure Material

Premium Solution

S Stainless steel (Div. 2/Zone 2
panels only)

A Cast aluminum

Value Solution

N No terminal housing
(non-factory sealed - Div. 1 & 2/
Zone 1 & 2)

Panel Phase

1 Single phase

3 Three phase

Breaker Spaces and Options (Combined No. of Circuits Required)†

Single pole breaker = 1 circuit

2 pole breaker = 2 circuits

3 pole breaker = 3 circuits

GFI = 1 additional circuit per breaker (suffix 'G')

EPD = 1 additional circuit per breaker (suffix 'E')

Ambient compensated breaker (+50°C) (suffix 'V')

Example:

(28) 1 pole 20 amp breakers = 28 circuits

+ (1) 1 pole 15 amp GFI breaker = 2 circuits

Total number of circuits = 30 (with 'G' for GFI circuit option)

30G

Insert Asterisk

Insert asterisk before
each branch breaker
series

Alike Branch Breakers

Insert quantity of alike
branch breakers

*

28

1

20

Branch Breaker Ampere Rating

20 20 amps

Insert Asterisk

Insert asterisk before
each branch breaker
series

*

Branch Breaker Pole Rating

1 Single pole breaker

2 2 pole breaker

3 3 pole breaker



†Even number of breaker spaces is required. For odd number of spaces, round up to next even number.

01 1 15G 3 M 225 GB

Alike Branch Breakers

Insert quantity of alike branch breakers

Branch Breaker Pole Rating

- 1 Single pole breaker
- 2 2 pole breaker
- 3 3 pole breaker

Branch Breaker Ampere Rating

15 = 15 amps
G = GFI breakers
15G = GFI with 15 amps

Main Breaker Follows

Space indicates that main breaker follows

Main Breaker Poles

Main breaker number of poles

Main Breaker

Indicates main breaker

Main Breaker Amperage Rating

Indicates main breaker amperage rating

Options

See list of available options on page 8



Ordering Information

D2D/EXD Series

Example: **D2DDS342V*42120-3M225-GB-GDB**

Class I, Division 2/Zone 2, Group B panel with:

- 480Δ VAC power panelboard with 3 phase, 3 wire
- 42 single pole 20 amp branch breakers
- 225 amp 3 pole main circuit breaker

D2D

Panel Type

D2D	Div. 2/Zone 2
EXD	Div. 1/Zone 1

Enclosure Size

B	24 circuit panel
C	42 circuit panel without main breaker
D	42 circuit panel with main breaker
F	30 circuit panel

Terminal Enclosure Material

Premium Solution

S	Stainless steel (sizes B, C, D only)
A	Cast aluminum

Value Solution

N	No terminal housing (non-factory sealed)
----------	--

Panel Phase

1	Single phase
3	Three phase

Breaker Spaces (Combined No. of Circuits Required)†

Example:

- Single pole breaker = 1 circuit
- 2 pole breaker = 2 circuits
- 3 pole breaker = 3 circuits

D

S

3

42

V

*

42

Breaker Options

V	Ambient compensated (+50°C)
----------	-----------------------------

Alike Branch Breakers

Insert quantity of alike branch breakers

Insert Asterisk

Asterisk denotes breaker characteristics follow



†Even number of breaker spaces is required. For odd number of spaces, round up to next even number.

1 20 3 M 225 GB GDB

Branch Breaker Pole Rating

- 1** Single pole breaker
- 2** 2 pole breaker
- 3** 3 pole breaker

Branch Breaker Ampere Rating

- 15** 15 amps
- 20** 20 amps
- 25** 25 amps
- 30** 30 amps
- 35** 35 amps
- 40** 40 amps
- 50** 50 amps
- 60** 60 amps
- 70** 70 amps

Main Breaker Follows

Space indicates that main breaker follows

Main Breaker Poles

Main breaker number of poles

Main Breaker

Indicates main breaker

Main Breaker Amperage Rating

Size B: 15 to 100 amps
 Sizes C, D, F: 15 to 225 amps

Options

GB Group B kit factory installed

GDB GDB frame breakers with 480Δ 3P 3W system

See list of available options on page 8



Dimensions

D2L/EPL Series

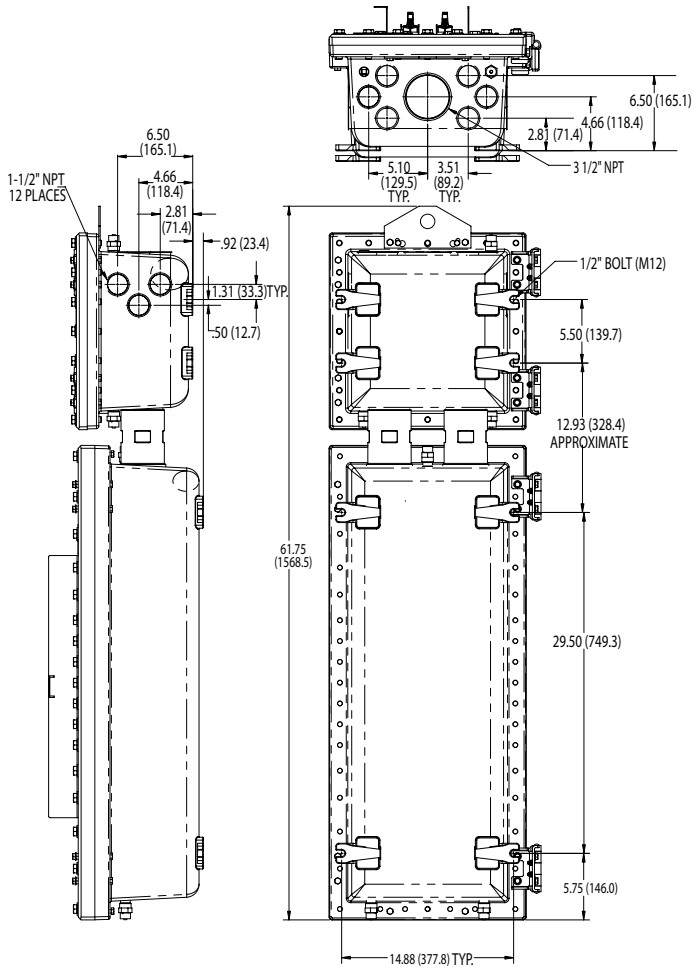

Size C and D Panel*
(with cast terminal housing)

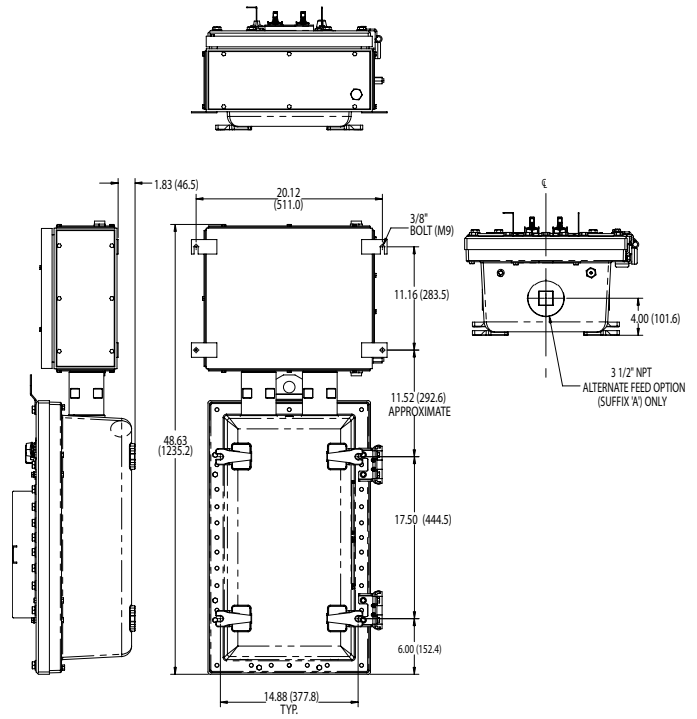

Size B Panel*
(with stainless steel terminal housing)

*Stainless steel terminal housing for sizes B, C, D and F are the same. Cast aluminum terminal housing for sizes B, C and D are the same.

Note: Value series non-factory sealed EPL*N panel dimensions are the breaker housing only and use standard entries shown on cast terminal housing.

Dimensions

D2D/EXD Series

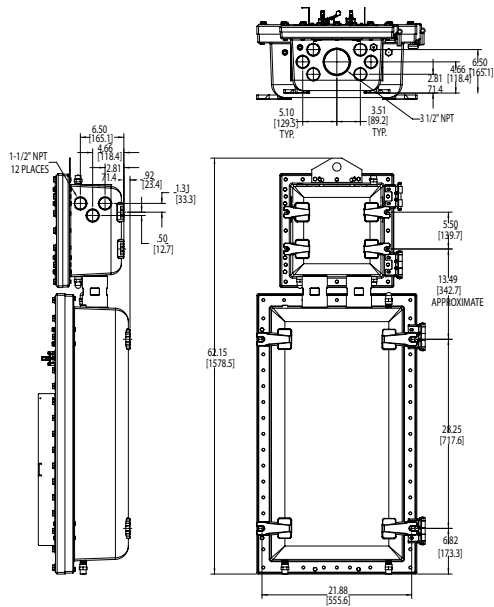

**Size C and D Panel
(with cast aluminum
terminal housing)**

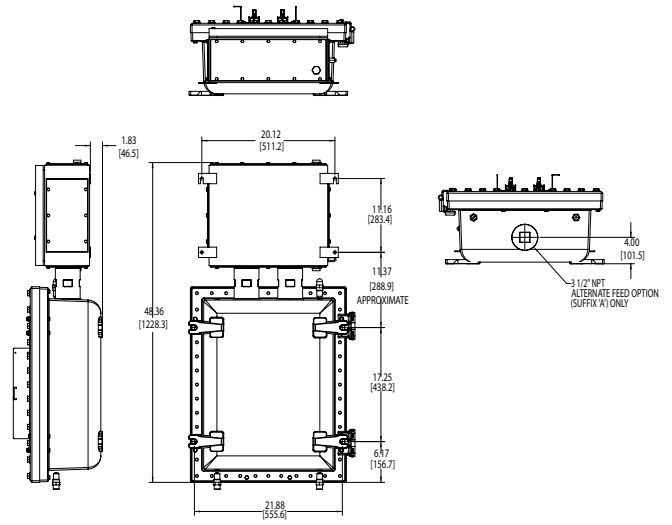

**Size B Panel
(with stainless steel
terminal housing)**

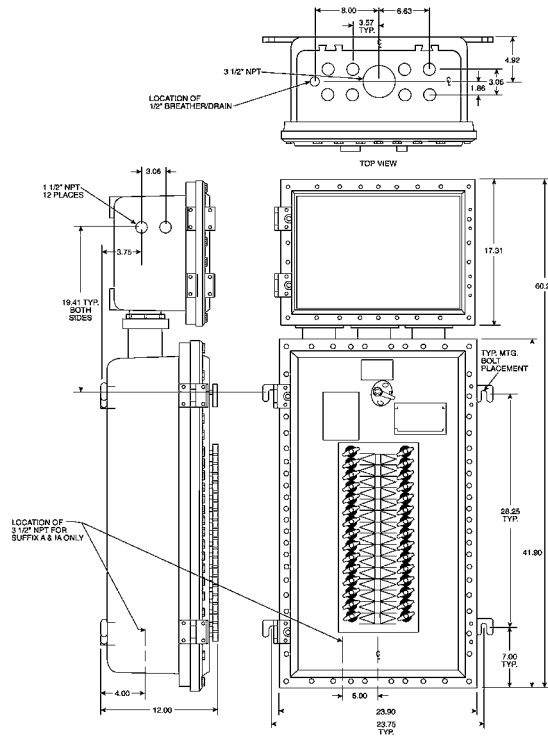

Size F Panel

†Stainless steel terminal housing for all sizes are the same. Cast aluminum terminal housing option for sizes C and D panels listed above are standard.

Note: Value series non-factory sealed EXD*N panel dimensions are the breaker housing only and use standard entries shown on cast terminal housing.

**U.S. (Global Headquarters):
Eaton's Crouse-Hinds Business**

1201 Wolf Street
Syracuse, NY 13208

(866) 764-5454
FAX: (315) 477-5179
FAX Orders Only:
(866) 653-0640

crouse.customerctr@
cooperindustries.com

For more information:

If further assistance is
required, please contact
an authorized Eaton
Distributor, Sales Office,
or Customer Service
Department.

Canada

Toll Free: 800-265-0502
FAX: (800) 263-9504
FAX Orders only: (866) 653-0645

Mexico/Latin America/Caribbean

52-555-804-4000
FAX: 52-555-804-4020
mxmercadotecnia@
cooperindustries.com

Europe (Germany)

49 (0) 6271 806-500
49 (0) 6271 806-476
sales.CCH.de@
cooperindustries.com

Middle East (Dubai)

971 4 4272500
FAX: 971 4 4298521
sales.CCH.me@
cooperindustries.com

Singapore

65-6645-9888
FAX: 65-6297-4819
chsi-sales@
cooperindustries.com

China

86-21-2899-3600
FAX: 86-21-2899-4055
cchsales@
cooperindustries.com

Korea

82-2-3484-6783
82-2-3484-6778
CCHK-sales@
cooperindustries.com

Australia

61-2-8787-2777
FAX: 61-2-9609-2342
CEASales@
cooperindustries.com

India

91-124-4683888
FAX: 91-124-4683899
cchindia@
cooperindustries.com

Eaton's Crouse-Hinds
1201 Wolf Street
Syracuse, NY 13208
Crouse-Hinds.com

Eaton
1000 Eaton Boulevard
Cleveland, OH 44122
United States
Eaton.com

© 2014 Eaton
All Rights Reserved
Printed in USA
Publication No. 5140-0714
July 2014

Eaton is a registered trademark.
All other trademarks are property
of their respective owners.