

EID fusible disconnect switch

Installation & maintenance information

SAVE THESE INSTRUCTIONS FOR FUTURE REFERENCE

APPLICATION

EID disconnect switches are suited for Class I, Divisions 1 & 2, Groups B, C, D; Class II, Division 1, Groups E, F, G; Class II, Division 2, Groups F, G; Class III; and Class I, Zones 1 & 2, Groups IIB+H₂, as defined by the National Electrical Code® as well as in damp, wet or corrosive locations.

Additionally, this series is suitable for NEMA 3, 4, 4X applications.

The EID disconnect should be installed, inspected, maintained and operated by qualified and competent personnel only.

INSTALLATION

⚠ WARNING

To avoid risk of electrical shock, electrical power must be OFF before and during product installation and maintenance. Failure to comply can result in damage to equipment, injury or death to personnel.

1. Select a mounting location that will provide suitable strength and rigidity for supporting the EID product. Weights and dimensions are listed below.

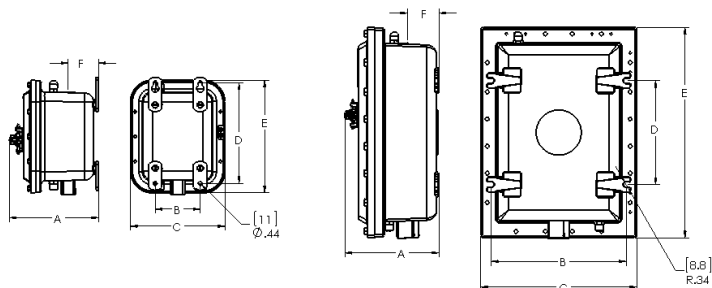

Figure 1

| Series | A | | B | | C | | D | | E | | F | | Weight | |
|-----------|-------|-----|-------|-----|-------|-----|-------|-----|-------|-----|------|----|--------|----|
| | in | mm | in | mm | in | mm | in | mm | in | mm | in | mm | lb | kg |
| EIDAF3030 | 10.02 | 255 | 7.00 | 178 | 12.67 | 322 | 13.13 | 333 | 14.67 | 373 | 3.50 | 89 | 47 | 21 |
| EIDAF3060 | 9.90 | 251 | 7.00 | 178 | 12.53 | 318 | 15.13 | 384 | 16.53 | 420 | 3.50 | 89 | 51 | 23 |
| EIDBF3100 | 10.40 | 264 | 15.00 | 380 | 17.31 | 440 | 11.50 | 292 | 23.31 | 592 | 3.50 | 89 | 108 | 49 |

2. Securely fasten enclosure to the mounting location, and then attach enclosure into conduit system. Install approved conduit or cable sealing fittings in all conduit entries within 18 inches (46cm) of enclosure per the National Electrical Code requirements.

⚠ CAUTION

To avoid risk of explosion, hazardous location information specifying Class and Group listing of each device is marked on the nameplate of each enclosure. Class and Group list for and device penetrating the enclosure must be suitable for the classification of location in which the enclosure is installed. Conduit sealing fittings MUST be installed in each attached conduit run within 18 inches of the enclosure per the National Electrical Code.

3. Ensure the operator is in the OFF position and then remove the cover bolts while securing cover. Carefully open the cover fully to prevent damage to the machined joint flame path and cover gasket.

⚠ CAUTION

To avoid the risk of explosion, hammers or prying tools must not be allowed to damage the flat machined joint surfaces or cover gasket. Do not handle covers roughly or place them on surfaces that might damage or scratch the flat machined joint surfaces.

⚠ CAUTION

To avoid the risk of explosion, do not use cover bolts as a means to lift the enclosure. Excessive force on the partially retracted cover bolts may damage the bolt. Use appropriate lifting method for safety.

4. Pull wires into enclosure, making sure they are long enough to make the required electrical connections. Install the proper wire clamps or other approved devices to hold the wires securely in place. Install the ground, line and load wires. Tighten the wire binding screws to torque values shown in Table 2.

NOTE:

- a. The internal grounding terminal shall be used as equipment grounding means. The external terminal is only a supplemental bonding connection.

| Series | Amperage | Wire range | Terminal torque value | |
|-----------|----------|------------|-----------------------|-----|
| | | | in.-lb. | N-m |
| EIDAF3030 | 30A | #10-#8 AWG | 35-40 | 4-5 |
| EIDAF3060 | 60A | #6-#3 AWG | 45 | 5 |
| EIDBF3100 | 100A | #1-1/0 AWG | 50 | 6 |

- b. Maximum wire sizes are recommended based on NEC minimum wire bending space at each terminal per designated enclosure. Select wire gauge per NEC standard.
 - c. Table 4 lists maximum wire gauges for 55°C ambient temperature.
 - d. Use copper wire only. Wire to be rated at 75/90°C.
5. For fusible disconnects, install Class J fuses. Contact Eaton's Bussmann Division for more fuse information.
 6. Test wiring for good connection by performing a continuity check. Also, check for unwanted grounds with an insulation resistance tester.

⚠ CAUTION

To avoid the risk of explosion, clean both machined joint surfaces of body and cover before closing. Dirt or foreign material must not accumulate on flat machined joint surfaces. Surfaces must seat fully against each other to provide a proper explosionproof joint.

7. Make sure that operator and fork are in the OFF position.

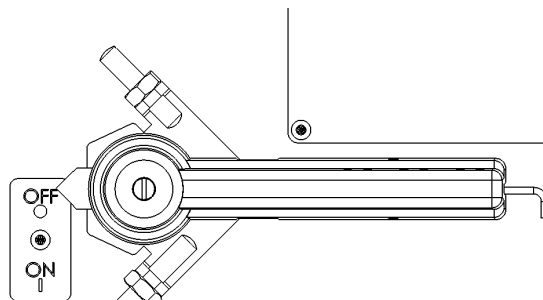

Figure 2

8. Fully tighten all cover bolts. See Table 3.

| Table 3 | | Torque value | |
|-----------|-------------|--------------|-------|
| Series | Cover screw | ft.-lb. | N-m |
| EIDAF3030 | 3/8"-16 | 35-40 | 48-54 |
| EIDAF3060 | 3/8"-16 | 35-40 | 48-54 |
| EIDBF3100 | 1/2"-13 | 40-45 | 54-61 |

NOTE: The rating for each disconnect can be observed in Table 4 below.

| Table 4 – Fusible switches, 3-pole, 600 VAC max., 250 VDC max. | | | | | | | |
|--|--------------|---------------|-----------|---------------------------|---------|---------|-------------------------|
| Series | Mfr's part # | Ampere rating | Fuse type | Maximum horsepower rating | | | Voltage |
| | | | | 480 VAC | 600 VAC | 250 VDC | |
| EIDAF3030 | DS161R | 30 | Class J | 15 | 20 | 5 | 600 VAC, 125/250 VDC |
| EIDAF3060 | DS262R | 60 | | 30 | 50 | 10 | |
| EIDBF3100 | DS363R | 100 | | 60 | 75 | 20 | |

CAUTION

To properly lock out device, put operating handle on OFF position. Press the silver lockout plate tab on the handle inward (note spring resistance). Place an OSHA approved lock or hasp through any of the three (3) holes of the handle and secure the device.

When it is safe to do so, verify that the handle cannot be moved to the ON position.

STOP ADJUSTMENT

1. Move operator to ON position.
2. Put light pressure on handle in the ON direction and hold in that position. Fork should be touching toggle.
3. Turn stop screw until it touches handle.
4. Tighten stop nut.
5. Move operator to OFF position.
6. Put normal pressure on handle in the OFF direction until the handle stops. Hold in that position.
7. Turn stop screw until it touches handle.
8. Tighten stop nut.

Eaton's Crouse-Hinds Division recommends an Electrical Preventative Maintenance Program as described in the National Fire Protection Association Bulletin NFPA 70B.

CAUTION

To avoid the risk of explosion, all unused conduit openings must be closed properly with an approved plug, drain or breather such as the Crouse-Hinds series PLG plugs or ECD breather/drains. NO CONDUIT OPENINGS ARE TO BE ADDED IN THE FIELD.

MAINTENANCE:

WARNING

To avoid electrical shock and personal injury, always disconnect primary power source before opening enclosure for inspection or service, and lock them out.

1. Electrical and mechanical inspections must be done on a regular basis. It is recommended that inspections be performed a minimum of once a year.
 2. If necessary to open enclosure for inspection or service, always disconnect primary power source and refer to cautionary statement or nameplate before opening cover. Area must be free of flammable gases and vapor before opening cover.
 3. Perform visual check for undue heating evidenced by discoloration of wires or other components, damage or worn parts or leakage evidenced by water or corrosion in the interior.
 4. Electrically check to make sure that all connections are clean and tight and that contacts in the components make and break as required.
 5. Mechanically check that all parts are properly assembled and operating mechanisms move freely.
- a. For more operator adjustment instructions, see Figure 3.

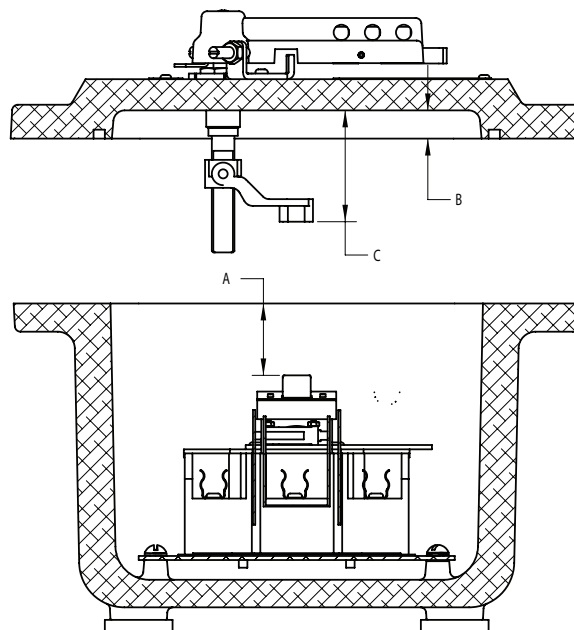

FORK HEIGHT IS TO BE SET FOR EACH UNIT ACCORDING TO THE FOLLOWING PROCEDURE:

1. WITH THE SWITCH IN THE OFF (DOWN) POSITION, MEASURE THE DISTANCE "A" FROM THE MACHINED FLANGE OF THE BODY TO THE TOP OF THE SWITCH TOGGLE.
2. MEASURE THE DEPTH "B" FROM THE MACHINED FLANGE TO THE INSIDE SURFACE OF THE DOMED COVER.
3. ADD DIMENSIONS "A" + "B" + .37" TO OBTAIN DIMENSION "C". THIS WILL BE THE HEIGHT FROM THE INSIDE SURFACE OF THE COVER TO THE BOTTOM OF THE OPERATING FORK AS SHOWN.

$$"C" = "A" + "B" + .37"$$

Figure 3

All statements, technical information and recommendations contained herein are based on information and tests we believe to be reliable. The accuracy or completeness thereof are not guaranteed. In accordance with Eaton's Crouse-Hinds Division's "Terms and Conditions of Sale," and since conditions of use are outside our control, the purchaser should determine the suitability of the product for his intended use and assumes all risk and liability whatsoever in connection therewith.