

**SAVE THESE INSTRUCTIONS FOR FUTURE REFERENCE**

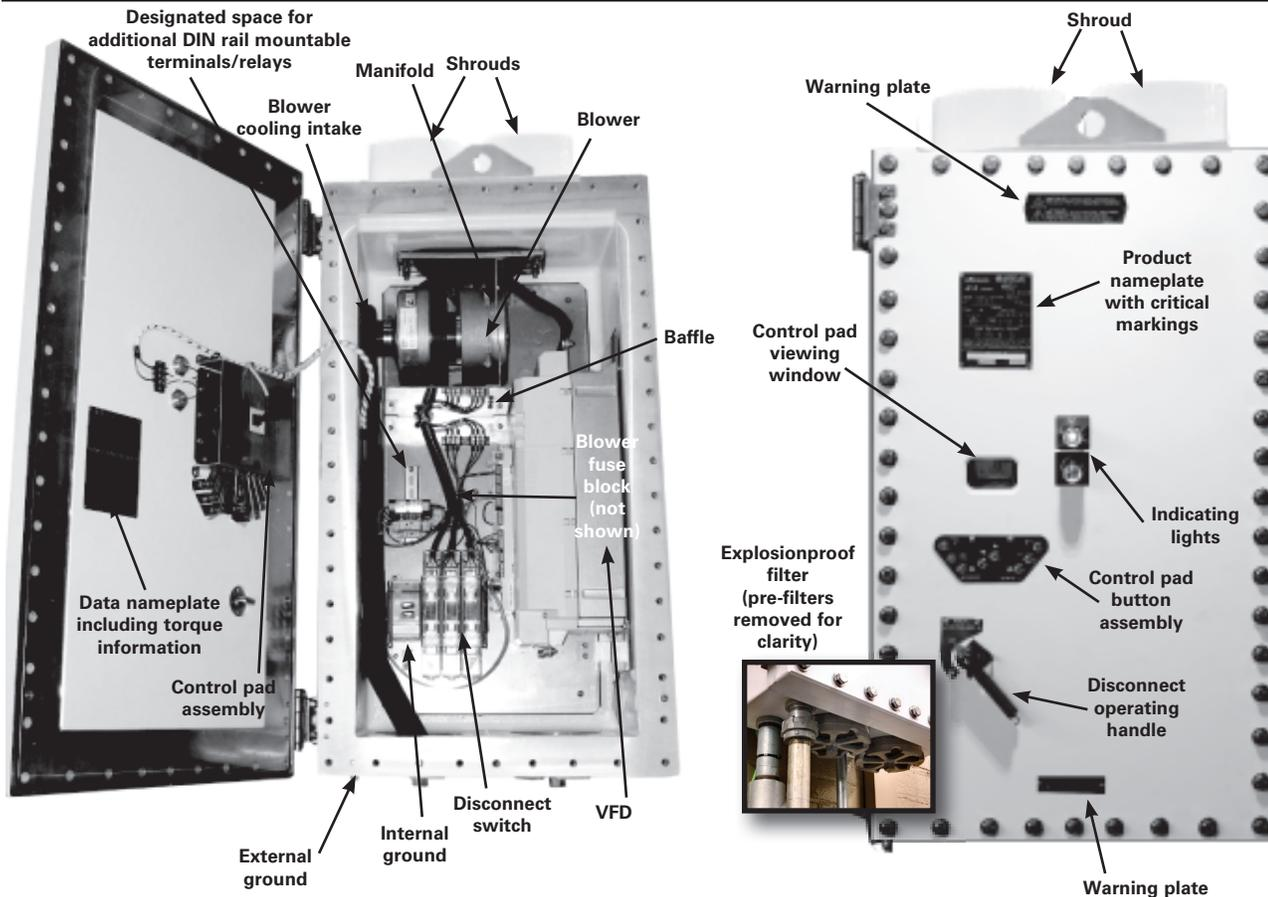

### TABLE OF CONTENTS

<b>1. Safety instructions</b>		
1.1 Approved applications	Page 2	
1.2 Electrical safety	Page 2	
1.3 Blower safety	Page 2	
1.4 Hot surfaces	Page 2	
1.5 Enclosure safety	Page 2	
<b>2. Mechanical installation</b>		
2.1 Airflow provisions - installation drawing	Page 3	
2.2 Weights	Page 4	
2.3 Lifting	Page 4	
2.4 Dimensional drawings	Page 5	
2.5 Mounting	Page 6	
2.6 Shroud installation	Page 6	
2.7 Pre-filter installation	Page 6	
<b>3. Electrical installation</b>		
3.1 Enclosure grounding - internal/external	Page 6	
3.2 Line feed	Page 6	
3.3 Load feed and shield grounding to drive	Page 6	
3.4 Control wire routing	Page 6	
3.5 Blower and signal schematic	Page 7	
3.6 Communication modules	Page 8	
<b>4. General operation</b>		
4.1 Keypad interface	Page 8	
4.2 Disconnect and lockout/tagout	Page 8	
<b>5. Maintenance</b>		
5.1 Drive maintenance		Page 9
5.2 Cooling system maintenance		Page 9
5.3 Periodic mechanical maintenance (torque verification, pushbutton lubrication, window cleaning)		Page 9
5.4 Status indication - filter maintenance		Page 9
5.5 Explosive event required maintenance		Page 9
<b>6. Technical data</b>		
6.1 Technical data chart		Page 10
6.2 Power loss (heat dissipation)		Page 10
6.3 De-rating factors and curves (ambient temperature, altitude, switching frequency)		Page 10
<b>7. Crouse-Hinds drive parameters</b>		
7.1 Parameter table		Page 10
<b>8. Replacement parts</b>		
8.1 Pre-filter kit		Page 10
8.1.1 Pre-filter installation instructions		Page 10
8.2 Sintered filter kit		Page 11
8.2.1 Sintered filter installation instructions		Page 11
8.3 Blower kit		Page 11
8.3.1 Blower installation instructions		Page 11
8.4 Pushbutton operator kit		Page 12
8.4.1 Pushbutton installation instructions		Page 12

# 1. SAFETY INSTRUCTIONS

The ACE explosionproof VFD should be installed, inspected and maintained by qualified and competent personnel.

## 1.1 APPROVED APPLICATIONS

The ACE explosionproof VFD is classified Class I, Divisions 1 & 2 for use in hazardous environments, and is designed to match the strict requirements of pumps, compressors, fans, separators and mixers in such process industries as:

- Oil and gas/refineries
- OEM skid builders
- Petrochemical
- Water/wastewater
- Pharmaceutical
- Food and beverage manufacturing

## 1.2 ELECTRICAL SAFETY

### WARNING: HIGH VOLTAGE

Electrical power must be OFF before and during inspection or service. Ensure electrical supply to the enclosure is disconnected, locked out and tagged out. Personnel injury or damage to equipment can occur if all power upstream from the enclosure is not fully disconnected prior to opening.

Before commissioning the drive and putting it into service, make sure that the motor and all driven equipment are suitable for operation throughout the speed range provided by the drive. The drive can be adjusted to operate the motor at speeds above and below the speed provided by connecting the motor directly to the line power.

### CAUTION

To ensure safety and VFD performance, grounding provisions for the enclosure, blower and VFD must be made before operating.

## 1.3 BLOWER SAFETY

### WARNING

To avoid cooling system malfunction, cooling system failure and personnel injury, close and seal the enclosure before energizing.

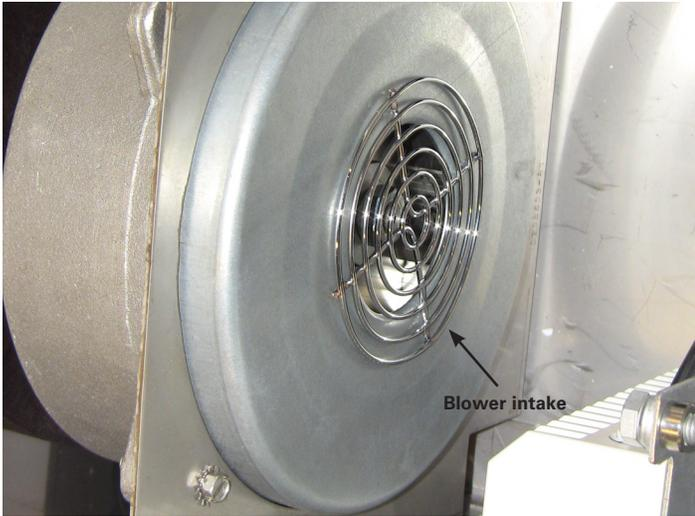

### WARNING: HIGH SPEED

To avoid personnel injury, DO NOT handle the blower or service the enclosure while energized.



### WARNING

To avoid cooling system malfunction, cooling system failure and personnel injury, remove all loose debris and deposits before energizing.

These blowers comply with EN 61800-5-1 safety standards.

The blower is non-serviceable. Refer to ACE KIT 3, Section 8.3, for replacement instructions.

## 1.4 HOT SURFACES

### WARNING: BURN HAZARD

To avoid personnel injury, use appropriate personnel protective equipment before handling and operating the device.

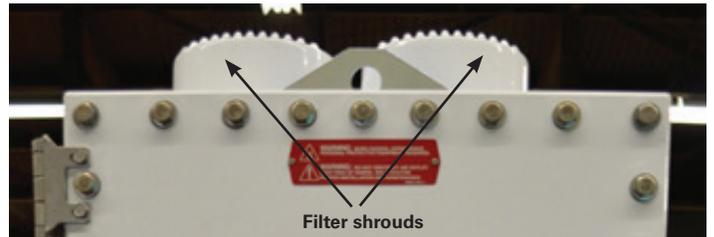

## 1.5 ENCLOSURE SAFETY

### WARNING

To avoid personnel injury and property damage, clean dirt and debris from flat ground joint surfaces before the cover is closed. NEVER energize this equipment if the flat ground joint has been scratched or damaged.

All pipe threaded connections into the enclosure require a minimum of five (5) full threads of engagement. All straight threaded connections into the enclosure require a minimum of eight (8) full threads of engagement. Personnel injury or equipment damage can result from threaded joints containing less than the minimum thread engagement required.

All unused conduit openings must be plugged. UL Listed plug must engage a minimum of five (5) full threads and be a minimum of 1/8" thick.

Conduit sealing fittings MUST be installed in each attached conduit run (within eighteen (18) inches of the enclosure) to comply with the latest edition of the National Electrical Code® (NEC) plus any other applicable code.

The cover must be properly fastened to the body with all cover bolts torqued to 40-45 ft.-lbs. (19.2-21.5 N-m). Personnel injury or equipment damage can result if the flat joint flame path is not properly fastened.

### WARNING

To avoid cooling system malfunction and personnel injury, be sure to torque the first eight (8) cover screws sequentially per Figure 1 before torquing the remaining screws.

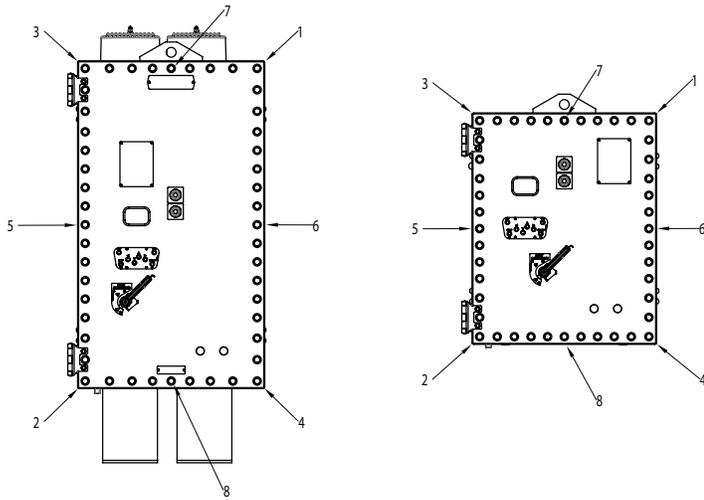

Figure 1

**⚠ WARNING**

To avoid personnel injury and property damage, DO NOT remove or modify the control pad viewing window.

## 2. MECHANICAL INSTALLATION

### 2.1 AIRFLOW PROVISIONS - INSTALLATION DRAWING

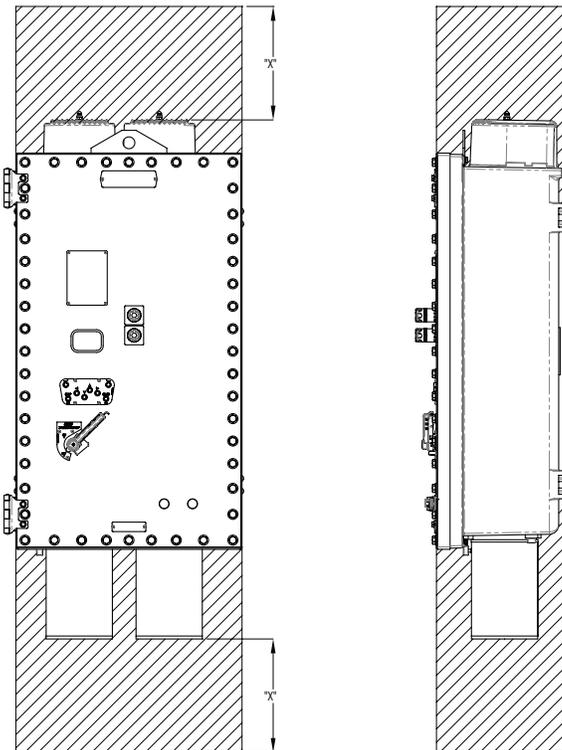

It is imperative that the enclosure be well ventilated to ensure reliable performance. Adequate space around the intake and exhaust of the enclosure MUST be accommodated. Eaton's Crouse-Hinds Division recommends 'x' be a minimum of 12 inches (0.3 meters).

## 2.2 WEIGHTS

Enclosure	Weight (lbs.)
1.5-5 HP	352
7.5-60 HP	552

## 2.3 LIFTING

1. Remove top and sides from shipping crate.
2. Remove lag bolts from enclosure mounting feet.

**⚠ CAUTION**

Do not attach shrouds or pre-filters until after enclosure is mounted.

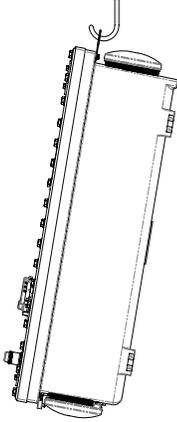

**⚠ CAUTION: UNBALANCED LOAD**

To avoid personnel injury, utilize the dedicated lifting eye and handle appropriately to ensure safe installation.

3. Use the dedicated lifting eye to mount enclosure on suitable mounting surface. Select a mounting location that will provide suitable strength and rigidity for supporting the enclosure and all components.

## 2.4 DIMENSIONAL DRAWINGS

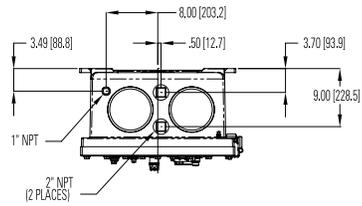
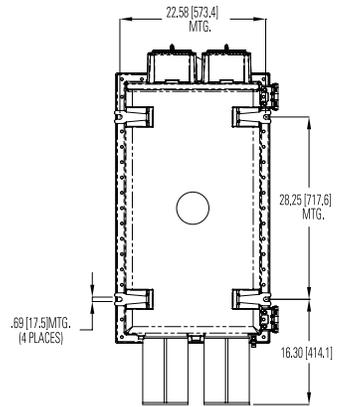
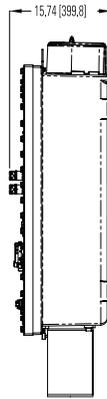
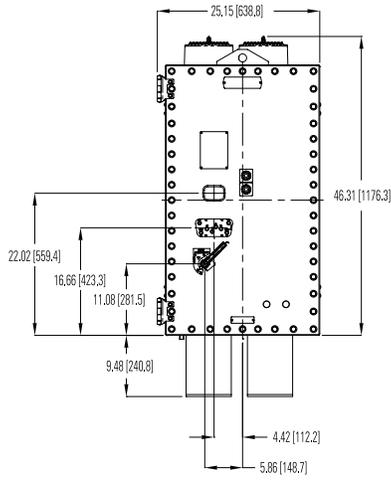
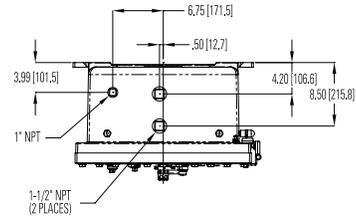
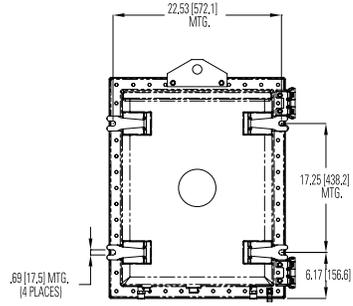
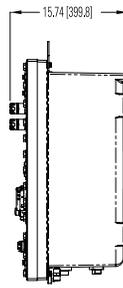
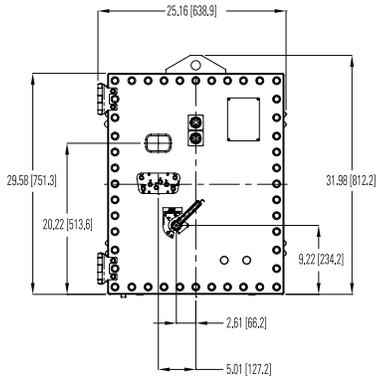

## 2.5 MOUNTING

1. Select a mounting location that will provide suitable strength, rigidity and space (per Section 2.1) for supporting the ACE system and all contained wiring.

### ⚠ CAUTION

To avoid cooling system malfunction, cooling system failure and personnel injury, be sure to mount the enclosure as depicted in Section 2.4.

### ⚠ CAUTION

To avoid cooling system malfunction, cooling system failure and personnel injury, be sure to mount the enclosure in a shaded area to avoid direct sunlight.

2. Refer to Section 2.2 for approximate weights and Section 2.4 for dimensions.
3. Install two (2) 5/8" bolts on left side.
4. Tap each of the four (4) mounting feet with a mallet to ensure tight assembly.
5. Align enclosure with the two (2) left side mounting feet engaged with the mounting bolts on selected mounting surface.
6. Tighten two (2) bolts on left side.
7. Install two (2) 5/8" bolts on right side and tighten.
8. After enclosure is positioned and secured in its permanent location, pull wires into the ACE system, making sure that they are long enough to make the required connections.

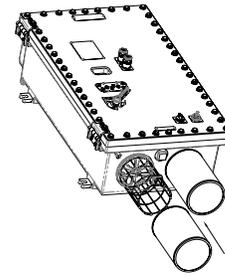

6. Be sure to stretch pre-filter elastic band completely around the explosionproof filter and seat the elastic band on the filter's threads. This will ensure all air flow to the bottom filters passes through the pre-filters.



## 2.6 SHROUD INSTALLATION

1. Remove rubber caps from explosionproof filters.
2. Insert threaded rods into the explosionproof filters. Leave 3-5/8 of threaded rod exposed.
3. Place shroud over explosionproof filters and threaded rod, with shroud opening facing back of enclosure. See Figure 2.
4. Insert washer and nuts onto end of threaded rod and tighten securely until shroud is firmly contacting the top wall of the enclosure. See Figure 3.

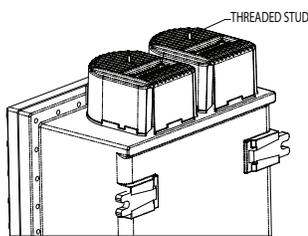

Figure 2

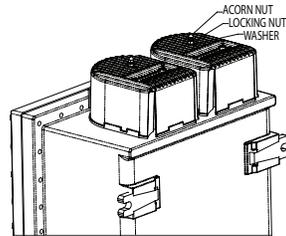

Figure 3

## 3. ELECTRICAL INSTALLATION

### 3.1 ENCLOSURE GROUNDING - INTERNAL/EXTERNAL

Grounding and bonding of the conduit and equipment is required by the National Electrical Code. A grounding conductor must be connected to the grounding lug(s) furnished.

Determine the type of distribution systems to be used that will comply with NEC requirements and ensure grounding continuity.

All conductive equipment that enclose the electrical conductors or attached equipment or forming part of such equipment must be grounded. A permanent connection must be made between all such equipment and the earth. Refer to Section 5.3 for the torque requirements of all terminations within this device.

### 3.2 LINE FEED

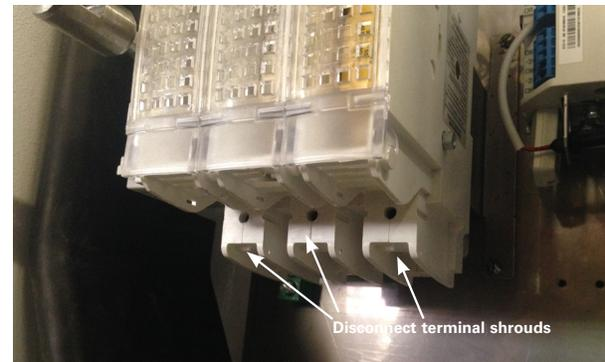

This equipment is designed for line connection directly to the integral disconnect switch. Factory wiring transmits power to the variable frequency drive.

1. Attach line conductors with phase A on the left, B center and C to the right (see torque table on page 9).

### 3.3 LOAD FEED AND SHIELD GROUNDING TO DRIVE

This equipment is designed for load connection directly from the variable frequency drive, although, in the case of an oversized VFD for the given motor, use the VFD and motor manufacturer's recommendations for proper motor overload protection. In certain cases, it is required to include additional motor overload protection between the VFD and the motor for proper motor overload protection. Always be sure to shield load wiring from line and control wiring to reduce noise. Refer to the drive manufacturer's manual for further details.

1. Remove VFD terminal shroud.
2. Attach load conductors with phase A to U2, B to V2, and C to W2 (see torque table on page 9).
3. Attach motor cable shielding to VFD ground (see recommendations by drive manufacturer).
4. Remove terminal knockouts and reinstall VFD terminal shroud. Refer to the drive manufacturer's manual for further information regarding drive installation.

## 2.7 PRE-FILTER INSTALLATION

1. Remove rubber caps from explosionproof filters.
2. Install wire guard using the bracket, screw and lock washer provided to the bottom filter(s).
3. Align guard with notches within the bracket as shown.

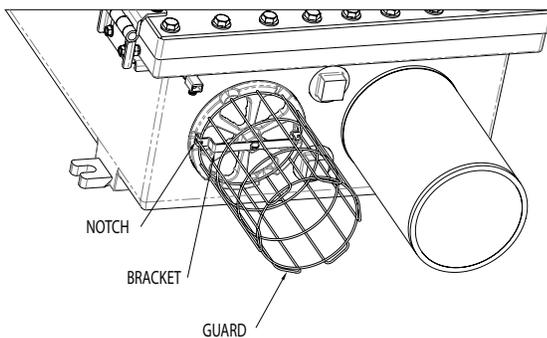

### Detailed view

4. Tighten screw.
5. Slip pre-filter mesh over guard.



### 3.6 COMMUNICATION MODULES

Available options:

Protocol	Suffix
Profibus .....	CP
Devicenet .....	CD
CAN Open .....	CC
Modbus .....	CM
Ethernet.....	CE

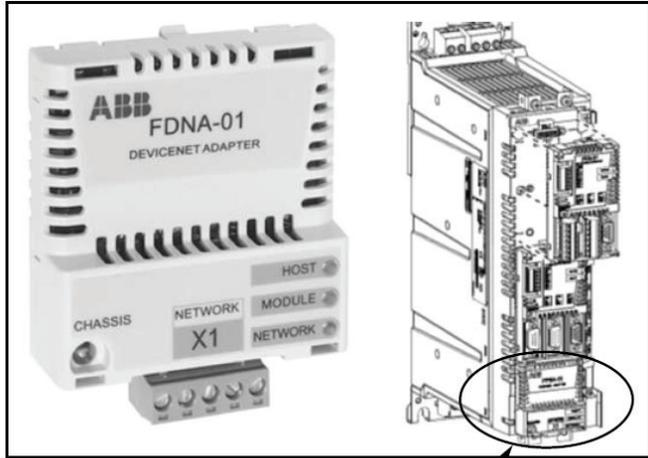

Slot 3

All communication modules will be installed in 'Slot 3' on the VFD. Plug in and fasten using the integral screw provided.

### 4. GENERAL OPERATION

#### 4.1 KEYPAD INTERFACE

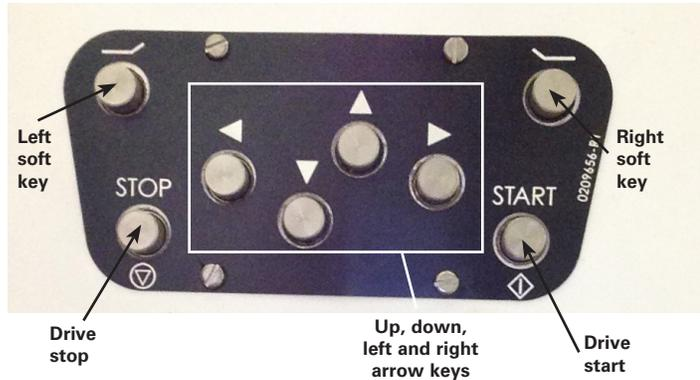

\*To review selection criteria, observe the control pad screen through the viewing window. Criteria is identified in the lower corners of the control pad corresponding to the buttons (as shown). Refer to the drive manufacturer's manual for additional instruction on the proper use and capability of the keypad interface.

### 4.2 DISCONNECT AND LOCKOUT/TAGOUT

The disconnect handle is furnished with three (3) holes for lockout/tagout purposes.

1. Turn handle to the 'OFF' position.
2. Depress lockout tab at the end of the handle.
3. Install OSHA approved lock or tag.
4. Release lockout tab.

#### ⚠ WARNING

To avoid ignition of explosive atmospheres, all circuits must be de-energized before opening cover.



#### ⚠ CAUTION

To avoid damage to the integral disconnect operating mechanism, be sure the disconnect coupling is in the off position before closing cover.

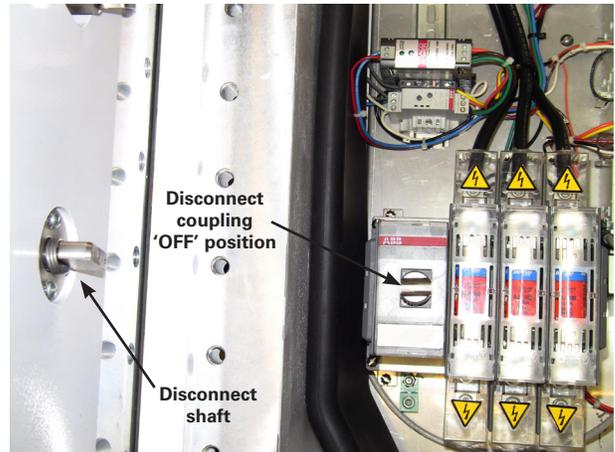

## 5. MAINTENANCE

### CAUTION

To avoid cooling system malfunction and cooling system failure, be sure to vacuum debris from the enclosure before energizing. NEVER use forced air for the removal of debris from this enclosure.

### 5.1 DRIVE MAINTENANCE

Periodic cleaning of the drive fan and heat sink is recommended. Removal of the drive from the enclosure is recommended to ensure debris does not obstruct the cooling system. Refer to the drive manufacturer's manual for additional maintenance recommendations and specific instructions.

### 5.2 COOLING SYSTEM MAINTENANCE

1. Clean pre-filter periodically. Remove pre-filter and rinse with water as needed.
2. Clean sintered filter as needed. Use of abrasives on the explosionproof filters may compromise the integrity of the cooling system.
3. Clean/inspect blower intake.

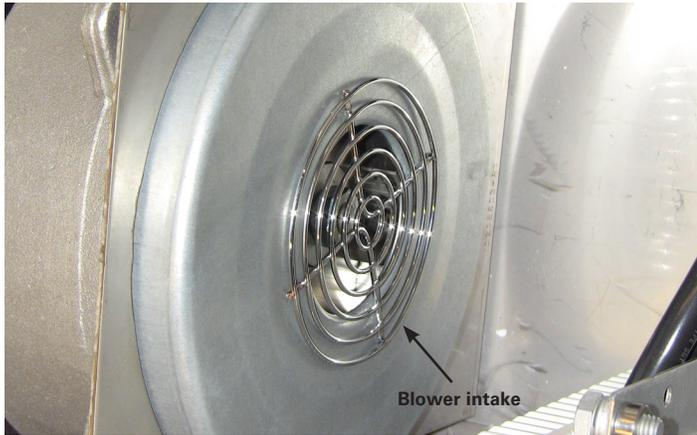

4. Perform visual, electrical and mechanical checks on all components on a regular maintenance schedule. NFPA 70B recommends maintenance intervals not exceeding 2 months.
5. Visually check for any damage to the filter assemblies, flat joints, threaded joints, journal joints and window.
6. Visually check for evidence of excessive heating within the enclosure.
7. Mechanically check that all parts are properly assembled and operating mechanisms are in proper working condition.
8. Verify airflow provisions are maintained per Section 2.1.

## 5.3 PERIODIC MECHANICAL MAINTENANCE (TORQUE VERIFICATION, PUSHBUTTON LUBRICATION, WINDOW CLEANING)

### Torque requirements

Item description	Wire range	Torque requirements
<b>Frame R1 drive (1.5-5 HP)</b>		
Line/load	24-12 AWG (0.25-4 mm <sup>2</sup> )	4.4-5.3 in.-lbs. (0.5-0.6 N-m)
Ground	N/A	13 in.-lbs. (1.5 N-m)
<b>Frame R2 drive (7.5-10 HP)</b>		
Line/load	20-10 AWG (0.5-6 mm <sup>2</sup> )	10.6-13.3 in.-lbs. (1.2-1.5 N-m)
Ground	N/A	13 in.-lbs. (1.5 N-m)
<b>Frame R3 drive (15-30 HP)</b>		
Line/load	10-2/0 AWG (6-70 mm <sup>2</sup> )	11 ft.-lbs. (15 N-m)
Line/load lugs	N/A	25 in.-lbs. (3 N-m)
Ground	N/A	25 in.-lbs. (3 N-m)
<b>Frame R4 drive (40-60 HP)</b>		
Line/load	10-2/0 AWG (6-70 mm <sup>2</sup> )	11 ft.-lbs. (15 N-m)
Line/load lugs	N/A	25 in.-lbs. (3 N-m)
Ground	N/A	160 in.-lbs. (18 N-m)
<b>Drive control</b>		
I/O terminals	24-12 AWG (0.5-2.5 mm <sup>2</sup> )	5 in.-lbs. (0.5 N-m)
<b>Disconnect</b>		
30 amp	14-6 AWG (2.1-13.3 mm <sup>2</sup> )	31 in.-lbs. (3.5 N-m)
60 amp	14-6 AWG (2.1-13.3 mm <sup>2</sup> )	31 in.-lbs. (3.5 N-m)
100 amp	12-1 AWG (3.3-42.2 mm <sup>2</sup> )	35.4 in.-lbs. (4.0 N-m)
<b>Timer relay</b>	20-14 AWG (0.5-2.5 mm <sup>2</sup> )	4.4-7.0 in.-lbs. (0.5-0.8 N-m)
<b>Relay</b>	24-12 AWG	3.5-5.3 in.-lbs. (0.4-0.6 N-m)
<b>Internal ground lug</b>	16-2/0 AWG	120 in.-lbs. (13.5 N-m)
<b>External ground lug</b>	6-1/0 AWG	50 in.-lbs. (5.6 N-m)
<b>Blower manifold</b>	N/A	20 in.-lbs. (2.3 N-m)
<b>Hose clamps</b>	N/A	20 in.-lbs. (2.3 N-m)
<b>Cover bolts</b>	N/A	40-45 ft.-lbs. (54.0-61.0 N-m)

### 5.4 STATUS INDICATION - FILTER MAINTENANCE

There are two (2) lights for the status indicator - a GREEN light to signify RUN and a RED light to signify STOP or ALARM condition.

- Solid red = power on/drive stopped/fault
- Solid green = drive running
- Blinking red = drive running in alarm mode; maintenance required
- Lights off = power off

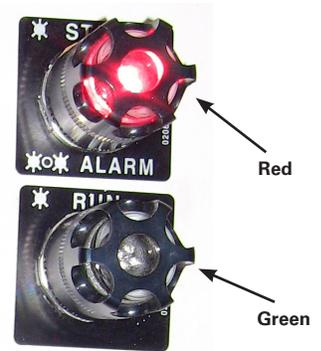

### 5.5 EXPLOSIVE EVENT REQUIRED MAINTENANCE

In the event of an explosion within the enclosure, the filter assemblies and pre-filters must be replaced. Personnel injury or equipment damage may result from failure to replace the filters with new filters after an explosion occurs within the enclosure. Inspect all other components and verify that they are in proper operating condition. Consult Eaton's Crouse-Hinds Division for replacement parts as needed.



### WARNING: BURN HAZARD

To avoid personnel injury, allow sufficient time for the enclosure to cool prior to servicing.

## 6. TECHNICAL DATA

### 6.1 TECHNICAL DATA CHART

Base Cat. #	Max. disconnect rating (amps)	Disconnect fuse type	Enclosure size	Input rating (amps)	Max. output rating (amps)	Nominal horsepower	Power loss (watts)	Temp. rating	Temp. de-rating factor
ACE10 1	30	J	1	2.3	3.0	1.5	106	T6	Figure 1
ACE10 2				3.1	3.6	2	112	T6	Figure 1
ACE10 3				4.0	4.8	3	132	T6	Figure 1
ACE10 5				6.6	8.0	5	178	T6	Figure 1
ACE10 7				12.0	14.0	7.5	606	T4A	Figure 1
ACE10 10	60	J	2	16.0	18.0	10	674	T4A	Figure 1
ACE10 15				20.0	25.0	15	737	T4A	Figure 1
ACE10 20				26.0	30.0	20	847	T4A	Figure 1
ACE10 25				30.0	35.0	25	875	T4A	Figure 1
ACE10 30				42.0	50.0	30	1008	T4A	Figure 1
ACE10 40	100	J	2	55.0	58.0	40	1217	T4A	Figure 1
ACE10 50				65.0	72.0	50	1397	T4A	Figure 1
ACE10 60				82.0	81.0	60	1577	T4A	Figure 2

\*Modified product designs may vary in terms of technical information. Contact factory for additional information.

Data shown is for standard catalog, 460 VAC drives. Refer to drive manufacturer's manual for all other voltage and performance specifications.

### 6.2 POWER LOSS (HEAT DISSIPATION)

When the ACE enclosure is not installed in a well ventilated area, provisions must be made to account for heat generation and ensure proper operation of the device.

### 6.3 DE-RATING FACTORS AND CURVES (AMBIENT TEMPERATURE, ALTITUDE, SWITCHING FREQUENCY)

The final drive output rating is a multiplication of all applicable de-rating factors.

#### Ambient temperature de-rating

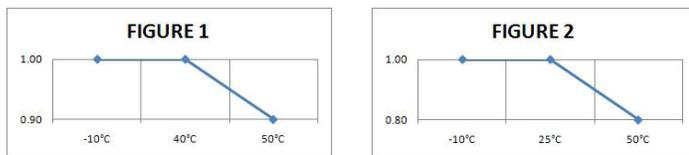

#### Altitude de-rating:

At altitudes from 1,000 to 4,000m (3,280 to 13,123 ft.) above sea level, the de-rating is 1% for every 100m (328 ft.).

**NOTE:** If the installation site is higher than 2,000m (6,560 ft.) above sea level, connection of the drive to an ungrounded (IT) or corner-grounded delta network is not allowed.

#### Low motor noise (switch frequency) de-rating:

Base Cat. #	Enclosure size	Input rating (amps)	Max. output rating (amps)	Nominal horsepower
ACE10 1	1	1.6	2.1	1
ACE10 2		2.3	2.6	1
ACE10 3		2.8	3.4	2
ACE10 5		4.0	4.8	3
ACE10 7		9.0	10.0	5
ACE10 10	2	10.0	12.0	7.5
ACE10 15		11.0	14.0	10
ACE10 20		15.0	17.0	10
ACE10 25		18.0	21.0	15
ACE10 30		24.0	29.0	20
ACE10 40	2	31.0	32.0	25
ACE10 50		36.0	40.0	30
ACE10 60		45.0	45.0	40

## 7. CROUSE-HINDS DRIVE PARAMETERS

### 7.1 PARAMETER TABLE

Parameter number	Parameter description	Parameter value
10.24	RO1 SOURCE	ADAPTIVE PROGRAM*
11.05	DIO1 FUNCTION	OUTPUT
11.06	DIO1 OUTPUT SOURCE	FAULT
11.09	DIO2 FUNCTION	OUTPUT
11.10	DIO2 OUTPUT SOURCE	RUNNING
19.11	EXT1/EXT2 SELECTION	DIG
20.01	EXT1 COMMANDS	CONTROL PANEL
20.02	EXT1 START TRIGGER TYPE	EDGE
22.11	SPEED REF1 SOURCE	CONTROL PANEL
<b>POTENTIOMETER OPTION (SUFFIX PT) ONLY</b>		
12.15	AIT UNIT SELECTION	VOLTS
12.17	AIT MIN	0.000V
12.18	AIT MAX	10.000V
22.11	SPEED REF1 SOURCE	AIT SCALED

\*Adaptive program is not configurable through control panel parameter menu, and is loaded to the drive at the factory. Adaptive program is critical for proper operation of the cooling system and must not be disabled.

## 8. REPLACEMENT PARTS

ACE systems are designed to provide years of reliable service. However, should the need for replacement parts arise, they are available through your Eaton's Crouse-Hinds Division Distributor. Assistance may also be obtained through your Eaton's Crouse-Hinds Sales Representative or the Eaton's Crouse-Hinds Customer Service Department.

### 8.1 PRE-FILTER KIT

ACE KIT1: pre-filter and hardware (1 pc.)

#### 8.1.1 PRE-FILTER INSTALLATION INSTRUCTIONS

1. Remove rubber caps from explosionproof filters.
2. Install wire guard using the bracket, screw and lock washer provided to the bottom filter(s).
3. Align guard with notches within the bracket as shown.

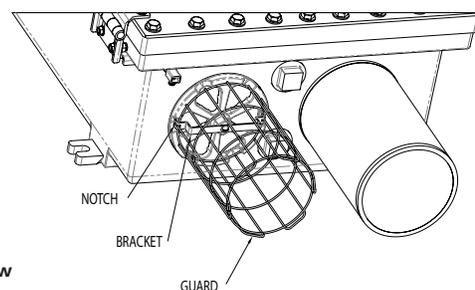

#### Detailed view

4. Tighten screw.
5. Slip pre-filter mesh over guard.

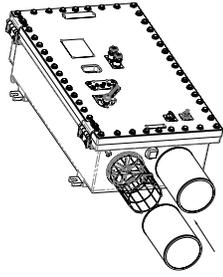

- Be sure to stretch pre-filter elastic band completely around the explosionproof filter and seat the elastic band on the filter's threads. This will ensure all air flow to the bottom filters passes through the pre-filters.

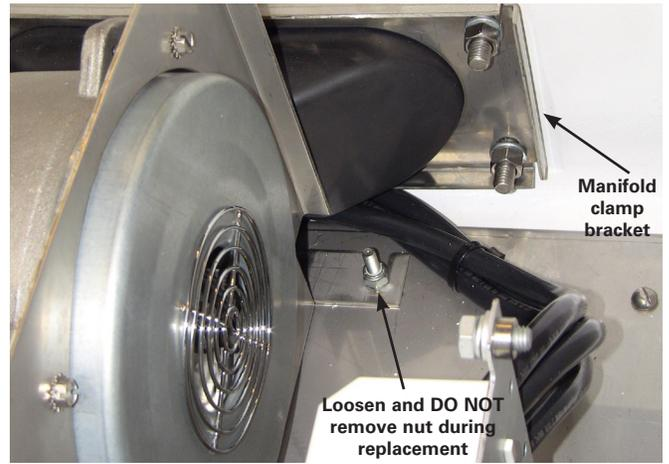

- Remove blower and brackets.
- Remove manifold and manifold clamp bracket.
- Remove blower cooling intake and hose clamp from old blower assembly and hold for re-assembly.
- Loosen and remove three (3) screws holding the baffle to the blower bracket. Remove baffle and hold for re-assembly.
- Attach baffle to new blower bracket using the same three (3) screws.
- Align new manifold to enclosure wall.
- Align new manifold clamp bracket to threaded studs. Be sure the manifold clamp bracket flanges point toward the interior of the enclosure.
- Install four (4) lock washers and nuts on threaded studs hand tight before applying required torque. Tighten to 20 in.-lbs. DO NOT over-tighten.
- Slide new blower/bracket assembly into place until fully seated, aligning to the threaded studs and the manifold.

## 8.2 SINTERED FILTER KIT

ACE KIT2: filter assembly (1 pc.)

### 8.2.1 SINTERED FILTER INSTALLATION INSTRUCTIONS

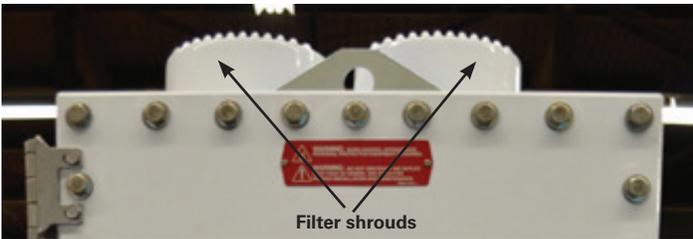

- Remove shroud and pre-filters and place all parts in a secure area.
- Using a 1" socket wrench, remove all filters from the enclosure (top and bottom).
- Remove rubber caps from explosionproof filters.
- Apply thread grease to threads of explosionproof filters. DO NOT remove.
- Install new filters (top and bottom) and torque each to 133 ft.-lbs. (180 N-m).
- Install pre-filters and shrouds; refer to Sections 2.6 and 2.7.

## 8.3 BLOWER KIT

ACE KIT3: blower, manifold and hardware (1 pc.)

### 8.3.1 BLOWER INSTALLATION INSTRUCTIONS

- Disconnect blower power, ground and control leads from terminal blocks.
- Loosen four (4) nuts holding blower bracket and baffle to mounting plate. DO NOT remove.
- Loosen and remove manifold clamp bracket nuts and lock washers. DO NOT remove jam nuts positioned behind the manifold clamp bracket.



**CAUTION**  
To avoid system malfunction and electrical shock, be sure that all wires are aligned in the baffle's wire pass through.

- Tighten nuts wrench tight.
- Tighten manifold hose clamp, while compressing the manifold to the blower, to 20 in.-lbs.
- Re-attach blower cooling intake and tighten hose clamp to 20 in.-lbs. Be sure to align bottom of blower cooling intake to the explosionproof filter at the bottom of the enclosure.



- Terminate the blower power wires to the appropriate terminal block (black to black).
- Perform a continuity check between each blower power terminal and each phase of the integral disconnect switch.
- Terminate the blower control wires to the appropriate terminal block (red to red).
- Perform a continuity check between each blower control terminal and the XROI relay on the variable frequency drive.
- Terminate the blower ground wire to the appropriate terminal block (with the blower control wires) (yellow/green to green)
- Perform a continuity check between the ground terminal and the ground lug adjacent to the integral disconnect switch.

## 8.4 PUSHBUTTON OPERATOR KIT

ACE KIT4: pushbutton operator, finger and hardware (8 pc.)

### 8.4.1 PUSHBUTTON INSTALLATION INSTRUCTIONS

1. Loosen and remove four (4) screws and lock washers from keypad bracket. Remove keypad and bracket.

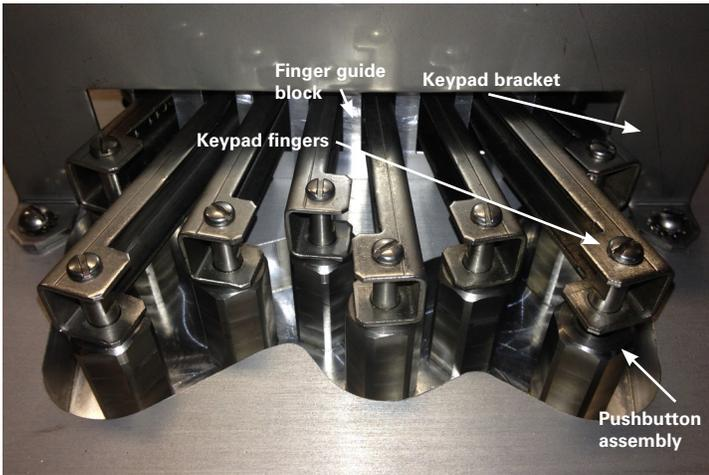

2. Loosen and remove eight (8) screws and lock washers from keypad fingers. Remove fingers.
3. Loosen and remove pushbutton assemblies.
4. Apply Eaton's Crouse-Hinds series STL lubricant lightly to the external threads of the pushbutton assembly.
5. Install new pushbutton assemblies and tighten wrench tight.
6. Re-install keypad fingers and orient fingers as shown in Detail A.

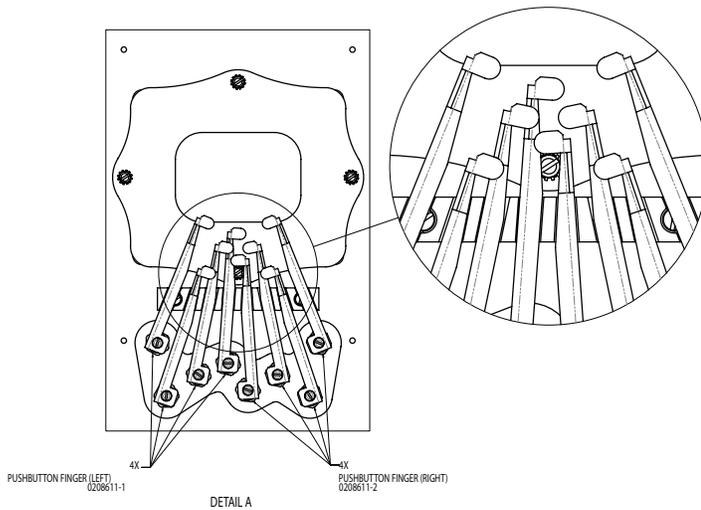

7. Install lock washers and screws retaining keypad fingers and tighten wrench tight.
8. Re-install keypad bracket and fasten using existing hardware. Tighten screws wrench tight.

All statements, technical information and recommendations contained herein are based on information and tests we believe to be reliable. The accuracy or completeness thereof are not guaranteed. In accordance with Eaton's Crouse-Hinds Division's "Terms and Conditions of Sale," and since conditions of use are outside our control, the purchaser should determine the suitability of the product for his intended use and assumes all risk and liability whatsoever in connection therewith.