

# Lighting panelboards

## EXD and D2D series - Sizes B, C & D

### Installation & maintenance information

IF 1574

SAVE THESE INSTRUCTIONS FOR FUTURE REFERENCE

#### APPLICATION

EXD and D2D panelboards provide a centrally controlled switching system and short circuit protection for feeder or branch circuits to control lighting, heating, appliances, heat tracing, motor and similar circuits.

EXD panelboards are designed for use in Class I, Division 1 & 2, Groups B (with Group B kit, or suffix -GB), C, D; Class II, Groups E, F, G; Class III hazardous areas as defined by the National Electrical Code® (NEC) and Canadian Electrical Code (CEC), as well as in damp, wet locations - indoors or outdoors - with UL Type 3, 4, 4X (with S752 or S753), 12.

D2D panelboards are designed for use in Class I, Division 2, Groups B (with Group B kit, or suffix -GB), C, D; Class II, Division 2, Groups F & G; Class III.

#### Enclosure only ratings

-25°C to 60°C	Groups B, C, D 10kAIC
	Groups C, D 65kAIC
cUL max. ambient +40°C	

#### WARNING

**To avoid electrical shock or explosion**, panelboards should be installed, inspected, maintained and operated by qualified and competent personnel. Read entire instructions before starting installation of this product. Contact your local Eaton's Crouse-Hinds Division sales representative, customer service or distributor if you have any questions.

#### CAUTION

**To prevent external fire or explosion of Group B atmospheres**, do not connect to a supply circuit having a capability of delivering more than 10,000 RMS symmetrical amperes.

For Groups C and D atmospheres, do not connect to a supply circuit having a capability of delivering more than 65,000 RMS symmetrical amperes at 240/480 VAC.



FIGURE 1 - MOUNTING DIMENSIONS AND WEIGHTS

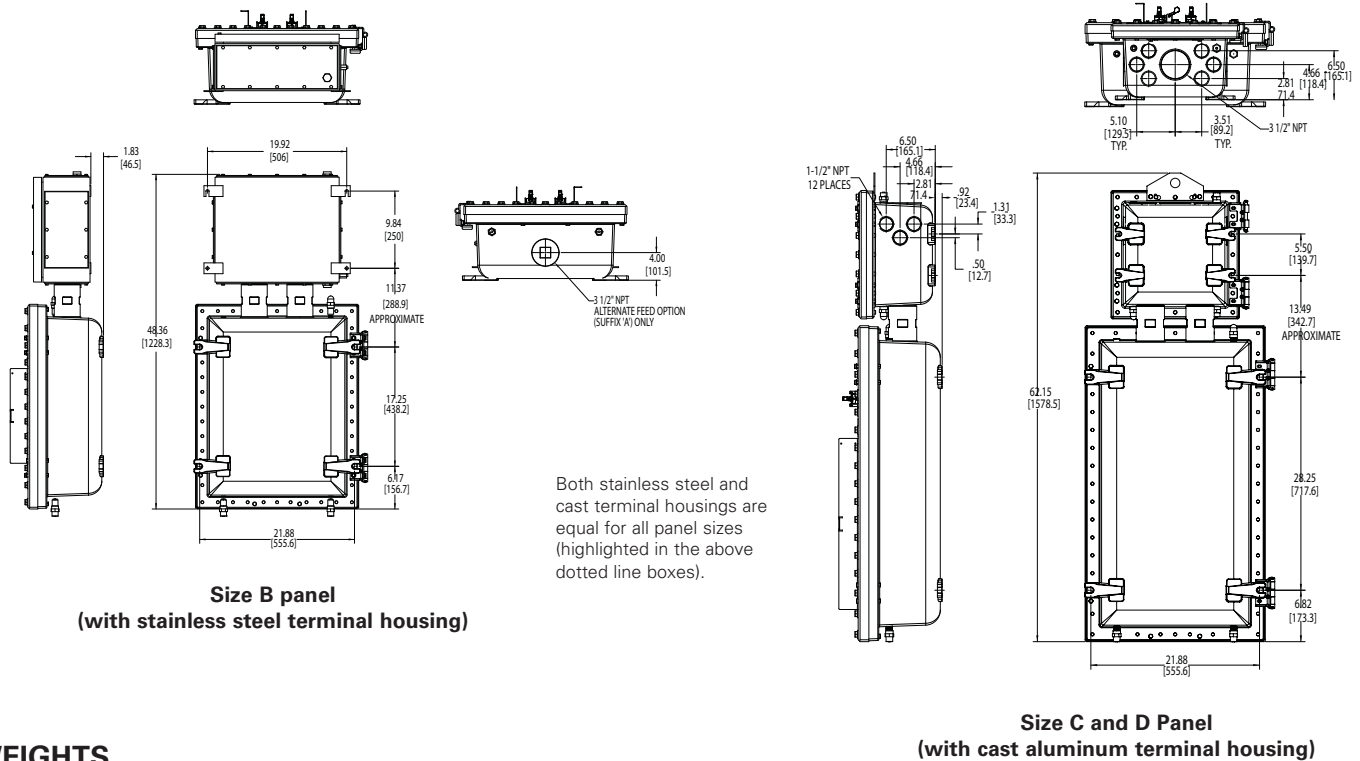

#### WEIGHTS

Cat. #	Product weight		Shipping weight	
	lbs.	kg.	lbs.	kg.
D2DBS	325	147.4	400	181.4
D2DBA	375	170.1	450	204.1
D2DCS	400	181.4	500	226.8
D2DCA	450	204.1	550	249.5
D2DDS	400	181.4	500	226.8
D2DDA	450	204.1	550	249.5
EXDBA	385	174.6	460	208.7
EXDBN	275	124.7	350	158.8
EXDCA	460	208.7	560	254.0
EXDCN	350	158.8	425	192.8

**⚠ WARNING**

To avoid personal injury or damage to the panelboard assembly, always securely fasten the cast aluminum breaker housing before securing the terminal housing.

**NOTE**

If your product was supplied with a sheet metal terminal housing, be sure to read the **D2D installation with sheet metal terminal enclosure** instructions completely before beginning installation. If your product was specified with alternate feed or no terminal housing, be sure to read the **alternate feed (suffix A) or no terminal enclosure installation** instructions completely before beginning installation.

**⚠ WARNING**

To avoid risk of explosion or equipment damage, do not scratch or damage flat joint flame path on either cover or body. Always clean both body and cover of dust and foreign particles prior to closing. Dirt or foreign material must not accumulate on flat joint surfaces.

**⚠ WARNING**

To avoid the risk of explosion, do not add or enlarge conduit entries in cast enclosures.

**GENERAL INSTALLATION, MOUNTING & LIFTING**

1. Select a mounting location that will provide suitable strength and rigidity for supporting the panelboard and all components. **Note:** only suitable for Sizes B, C and D.

Refer to Figure 1 for mounting dimensions and approximate weights. **Note:** Refer to field installable kits - section D if you are using an EXDA MTG KIT or D2DS MTG KIT installation.



2. Install detachable mounting feet while enclosure is on the floor or work bench.
  - Insert wedge shaped mounting feet into dovetail on all cast enclosures.
3. Use dedicated lifting eye to mount enclosure on suitable mounting surface. Refer to lifting diagrams (Figure 2) for appropriate lifting procedure.
4. Align enclosure with the two (2) left side mounting feet on selected mounting surface. While continuing to support the enclosure in position, install the right two (2) bolts of breaker enclosure. Securely tighten all bolts around breaker enclosure. If a terminal housing has been supplied, securely fasten four (4) remaining bolts for that enclosure after breaker housing is fastened.

**FIGURE 2 - LIFTING DIAGRAMS**

**Standard D2D with stainless terminal housing**

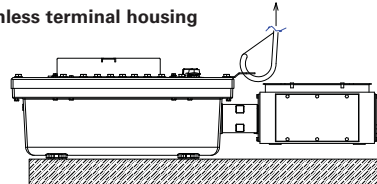

**Standard D2D with cast aluminum terminal housing**

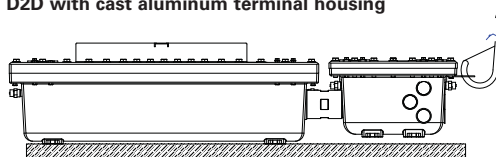

**Note:** There is a distance between terminal and breaker enclosure mounting surfaces. Do not bend or distort union assemblies. Provide adequate mounting or use available mounting kit.

**⚠ WARNING**

**Personnel injury or damage to equipment could result if sealing fittings are not installed properly.**

All conduit entries must be plugged. Any plastic plug must be replaced with a PLG type plug prior to use.

Division 1 panels with conduit runs 2" and higher need sealing fittings installed within 18" of enclosure

3-1/2" or greater entries for Division 1 EXD\*A panels require external seal.

All alternate feed panels require external seals to breaker housing. **Failure to comply could result in death to personnel or damage to equipment.**

5. With panelboard securely fastened to the mounting surface, remove plastic plugs from desired entries.
6. After enclosure is positioned and secured in its permanent location, pull wires into panelboard terminal enclosure, making sure that they are long enough to make the required connections.

Incoming lug terminals	Panel sizes B, C, D
Line (A, B, C) wire range	4-4/0
Branch circuit (1, 3, 5) wire range	10-0
Branch circuit (balance) wire range	24-8
Neutral line wire range	6-350 MCM
Neutral circuit wire range	14-4
Ground line wire range	6-350 MCM
Ground circuit wire range	14-4

**Note:** GHB breakers are suitable for 480Y/277 volts (3-phase, 4-wire systems), and are not suitable for 480Δ applications.

7. Make sure all screws and bolts are tightened to the appropriate torque values found in Chart 1 below.

**Chart 1 - torque requirements**

Item description	Wire range	Torque req.
Power terminals (A, B, C)	4-4/0	74-83 in.-lbs.
100 amp branch terminals (1, 3, 5)	6-0	21.8-26.1 in.-lbs.
50 amp branch terminals	24-8	7.1-8.9 in.-lbs.
Ground/neutral strip	14-10	35 in.-lbs.
	8	40 in.-lbs.
	6-4	45 in.-lbs.
Ground/neutral and chassis lugs (3/8")	2-1/0	50 in.-lbs.
	6-350 MCM	375 in.-lbs.
Quicklag breaker wire terminals (used on D2L/EPL models)	14-10	20 in.-lbs.
	8	25 in.-lbs.
	6-4	27 in.-lbs.
Type GHB breaker wire terminals (used on D2D/EXD models)	3-1/0	45 in.-lbs.
	14-10	20 in.-lbs.
	8	40 in.-lbs.
'F' frame breaker wire terminals	6-4	45 in.-lbs.
	3-1/0	45 in.-lbs.
Breaker to bus screws (#10)	3-4/0	50 in.-lbs.
Circuit breaker body ground lug	N/A	28-32 in.-lbs.
D2L-S or D2D-S terminal cover screws	4	120 in.-lbs.
D2L-S or D2D-S gland plate screws	N/A	35 in.-lbs.
D2L-S or D2D-S ground stud	N/A	18 in.-lbs.
D2L-S or D2D-S ground stud	N/A	35 in.-lbs.
1/2" enclosure cover bolts	N/A	40-45 ft.-lbs.
5/16" hinge screws	N/A	25-30 ft.-lbs.

**All inverted panels with terminal housings or non-factory sealed panels without terminal housing**

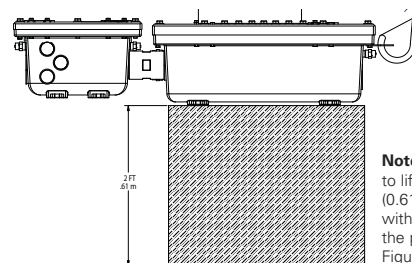

**Note:** For all inverted panels, prior to lifting with eye, place on a 2 ft (0.61m) staging surface that can withstand the approximate weight of the panel. Panel weights are listed in Figure 1.

# D2D INSTALLATION WITH STAINLESS STEEL TERMINAL ENCLOSURE

Refer to the **General Installation** instructions before proceeding.



**To avoid the risk of water ingress**, when removing the gland plates, do not damage or compromise the gasket. Contact Crouse-Hinds for replacement gland plates if damaged.

**CHART 2**

SPACING CHART FOR MYERS HUBS CONDUIT															
HOLE SIZE.	COND. SIZE.	1/4	3/8	1/2	3/4	1	1 1/4	1 1/2	2	2 1/2	3	3 1/2	4	5	6
9/16	1/4	1 1/16													
1 1/16	3/8	1 5/32	1 1/4												
7/8	1/2	1 5/16	1 13/32	1 9/16											
1 1/8	3/4	1 7/16	1 17/32	1 11/16	1 13/16										
1 3/8	1	1 19/32	1 11/16	1 27/32	1 31/32	2 1/8									
1 3/4	1 1/4	1 25/32	1 7/8	2 1/32	2 5/32	2 5/16	2 1/2								
2	1 1/2	1 31/32	2 1/16	2 7/32	2 11/32	2 1/2	2 11/16	2 7/8							
2 1/2	2	2 7/32	2 5/16	2 15/32	2 19/32	2 3/4	2 15/16	3 1/8	3 3/8	3 3/8	3 5/8				
3	2 1/2	2 15/32	2 9/16	2 23/32	2 27/32	3	3 3/16	3 3/8	3 5/8	3 7/8					
3 5/8	3	2 25/32	2 7/8	3 1/32	3 5/32	3 5/16	3 1/2	3 11/16	3 5/16	4 3/16	4 1/2				
4 1/8	3 1/2	3 3/32	3 3/16	3 11/32	3 15/32	3 5/8	3 13/16	4	4 1/4	4 1/2	4 13/16	5 1/8			
4 5/8	4	3 11/32	3 7/16	3 19/32	3 23/32	3 7/8	4 1/16	4 1/4	4 1/2	4 3/4	5 1/16	5 3/8	5 3/4		
5 11/16	5	4 1/32	4 1/8	4 9/32	4 13/32	4 9/16	4 3/4	4 15/16	5 3/16	5 7/16	5 3/4	6 1/16	6 5/16	7 1/8	
6 3/4	6	4 13/32	4 1/2	4 21/32	4 25/32	4 15/16	5 1/8	5 5/16	5 9/16	5 13/16	6 1/8	6 7/16	6 11/16	7 3/8	7 3/4
		1 9/32	1 1/16	2 7/32	3 1/32	1 1/8	1 5/16	1 1/2	1 3/4	2	2 5/16	2 5/8	2 7/8	3 9/16	3 15/16

Minimum space from center of conduit to nearest obstruction.

- Dimensions in black squares are centers for conduits of same size. Example: How close may 3" conduits be spaced? Answer 4 1/2".
- Dimensions in grey squares are for centers of conduits NOT of the same size. Example: What is the minimum spacing for 2" and 3/4" conduit? Read down column marked 3/4" to figure opposite 2" and find dimensions is 2 19/32".
- Minimum spacing dimensions as shown will give approximately 1/8" clearance between locking nuts.



**Note:** Terminal cover is removable to assist in the installation process.

- Remove gland plates and drill desired conduit entries in accordance with the spacing chart for Myers hubs (Chart 2) and the gland plate dimensional drawing (Figure 3).

**NOTE**

Drill conduit entries in "designated area" found in the gland plate dimensional drawing (Figure 3). Be sure to consider wiring and bending when planning entries.

**FIGURE 3 - GLAND PLATE DIMENSIONAL DRAWING**  
inches (millimeters)

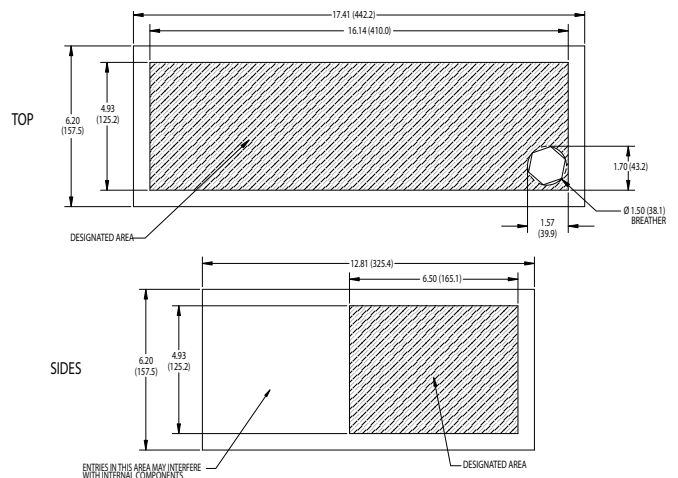

- Install appropriate Myers hubs per desired entries selected.
- Reinstall gland plate to stainless steel terminal housing and be sure to tighten screws to the torque values provided in the torque requirement chart (Chart 1).

## NOTE

For replacement gland plates, please refer to field installable kits - section E - adding a gland plate hub kit.

4. Install conduit using Myers hub connections.
5. Make sure all screws and bolts are tightened to the appropriate torque values found in Chart 1.

## ALTERNATE FEED (SUFFIX A) OR NO TERMINAL ENCLOSURE INSTALLATION

### WARNING

**Personal injury or equipment damage** can result from a compromised or damaged flat joint flame path. Do not scratch or damage flat joint flame path on either cover or body. Always clean both body and cover from dust and foreign particles prior to closing. Dirt or foreign material must not accumulate on flat joint surfaces.

Refer to the **General Installation** instructions before proceeding.

1. Unthread cover bolts from breaker enclosure and swing open on its hinges.
2. Attach sealing fittings and pull wires through desired entrance(s).

**Note:** Ensure all terminals are torqued to appropriate values. Please refer to Chart 1.

3. Connect main power directly to main lugs (with main lug only panels) or to main circuit breaker. Ensure proper insulation is installed for Size D panels when installing and wiring to main breaker. Refer to Step 5 on page 7 in "Adding a circuit breaker."
4. Bring in branch power through desired entries and connect directly to breaker. Please ensure terminals are tightened to torque values found in Chart 2. For factory sealed panels with terminal housing, please skip Steps 5 and 6, and refer to Step 7.
5. For no terminal housing panels, remove four (4) actuator plate screws and actuator plate (see picture below). Bring in branch power through desired entries and connect directly to breaker. Be sure to tighten terminals to the appropriate torque values found in Chart 1.

### WARNING

**Personnel injury or damage to equipment could result if sealing fittings are not installed properly.** All conduit entries in circuit breaker enclosure must have a sealing fitting installed within 18" of entry or plugged with a PLG plug.

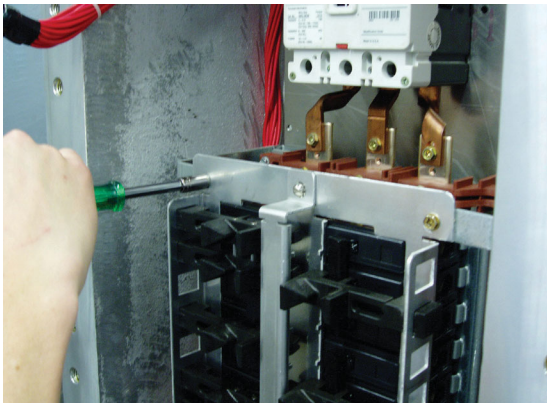

6. Once branch connections have been completed, reattach actuator plate. Ensure that actuator plate marking "TOP" is installed in the upward position. Make sure actuator plate properly fits onto breakers and is securely connected to brackets with four (4) actuator plate screws.
7. Close enclosure cover, making sure that bolts are retracted to prevent scratches or damage to the flange surface. Using only the bolts provided with the enclosure, tighten all bolts to 40-45 lbs.-ft. (191.5-215.4 N-m).

# FACTORY WIRING DIAGRAMS

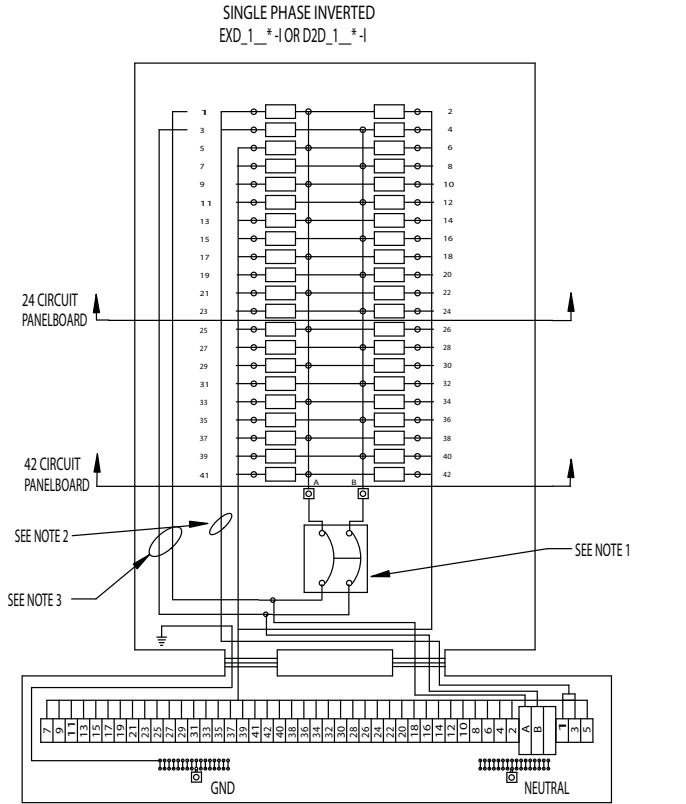
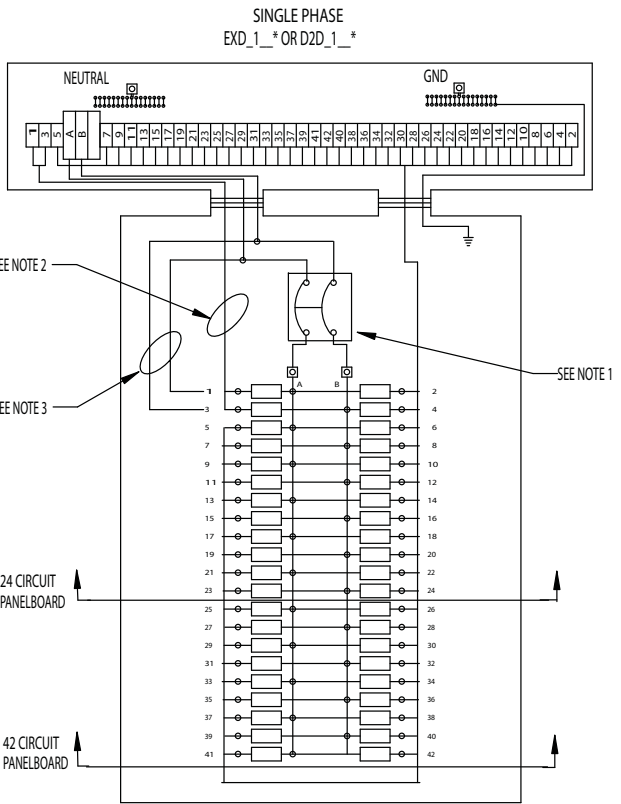
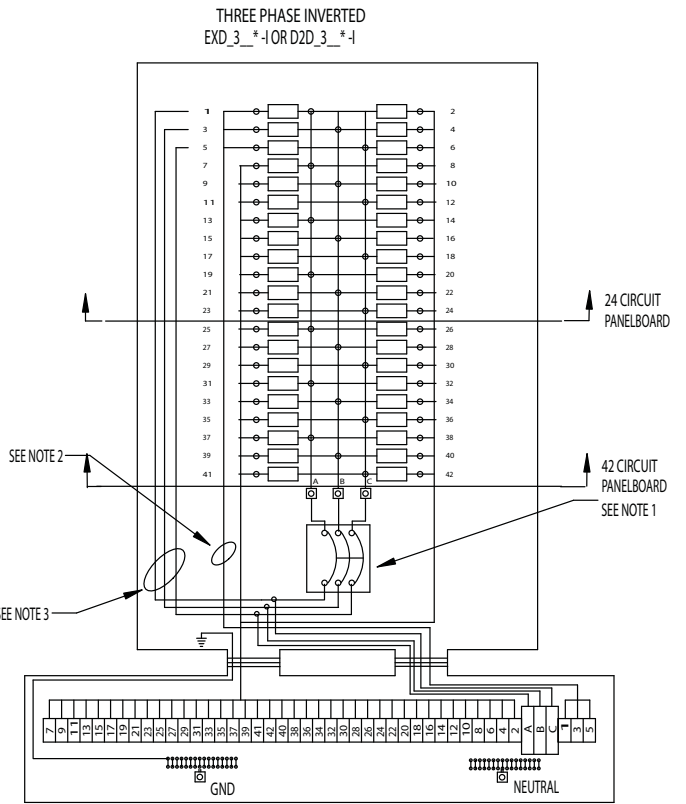
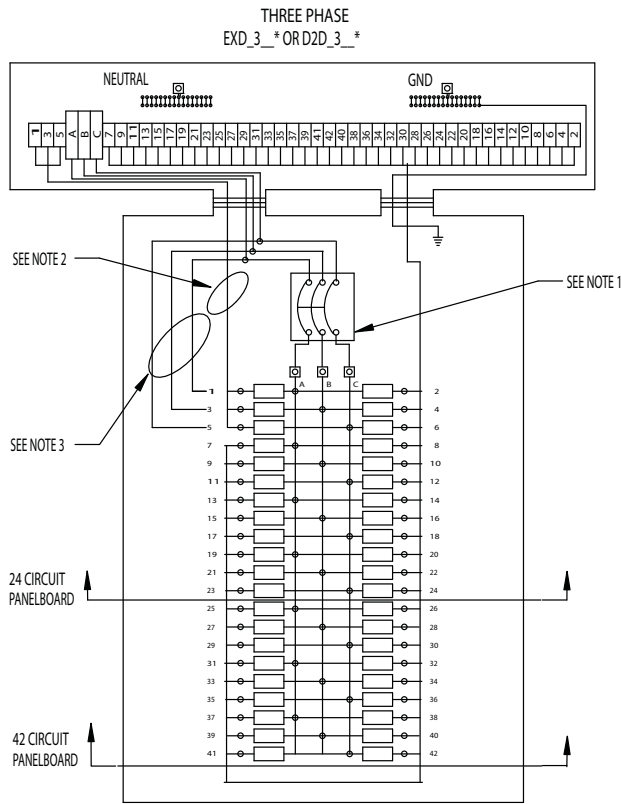

**Notes:**

1. Shown with optional main circuit breaker (24 and 42 circuit panels only).
2. Not used if back fed main breaker installed unless needed for branch breakers rated over 50 amps.
3. Wired from main terminal block in terminal enclosure if back fed main breaker installed.

# FACTORY WIRING DIAGRAMS CONTINUED

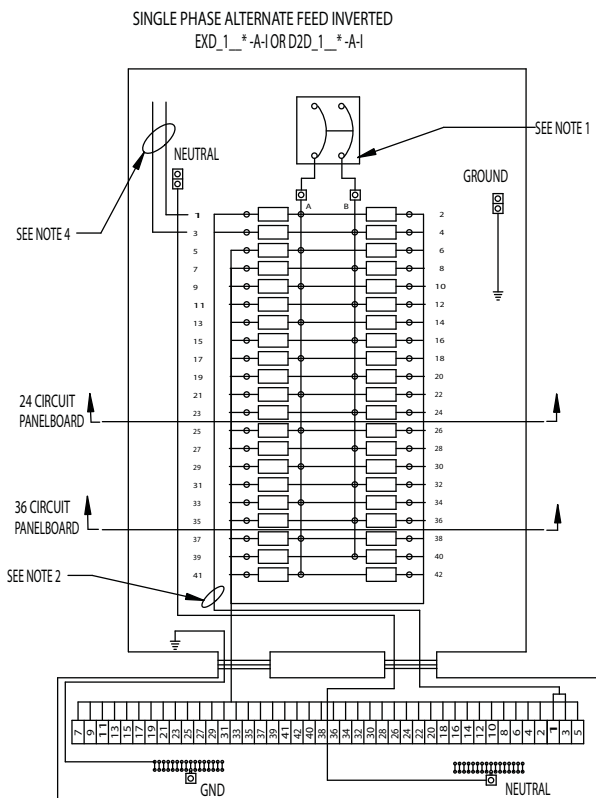
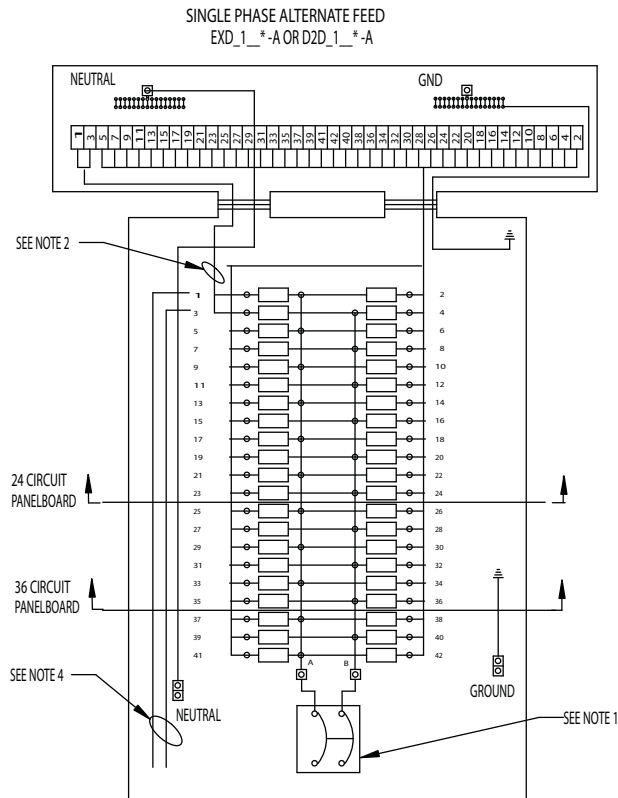
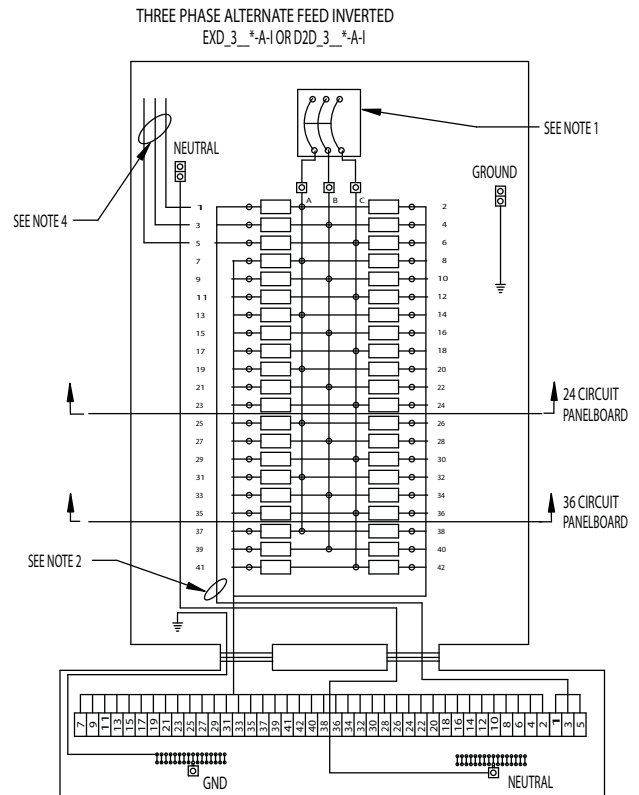
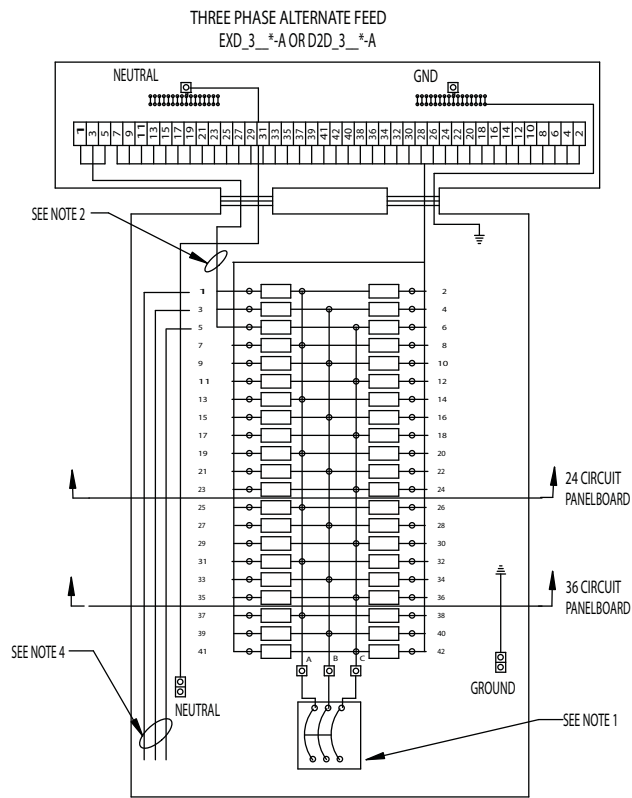

**Notes:**

1. Shown with optional main circuit breaker (24 and 36 circuit panels only).
2. Not used if back fed main breaker installed unless needed for branch breakers rated over 50 amps.
3. Wired from main terminal block in terminal enclosure if back fed main breaker installed.
4. Customer connection if supplied with back feed main breaker.

## FIELD INSTALLABLE KITS

### A. Adding a circuit breaker (EXD HDL 123) Sizes B, C and D

#### ⚠ WARNING

To avoid the risk of explosion or equipment damage, do not scratch or damage flat joint flame path on either cover or body. Always clean both body and cover of dust and foreign particles prior to closing. Dirt or foreign material must not accumulate on flat joint surfaces.

- De-energize panel, open circuit breaker enclosure, and make sure bolts are retracted in cover.
- Remove operator plug from desired position and install operator bearing until fully threaded into cover. If handles are located in either two (2) operator positions above selected location, removing handles and swinging operator pins out of the way is required. Ensure all operator pins are between 1 to 2 turns when completed and pointing down. When operator shaft installation is complete, securely fasten all handles.
- Install operator shaft assembly until fully seated. Now turn shaft counterclockwise between 1 to 2 turns. Operator pin must be pointing down. **Note:** Failure to turn shaft to between 1 to 2 turns will result in improper operation and could cause damage to product.
- Install handle with screw and washer provided to shaft on the cover exterior.
- Remove actuator plate and install branch circuit breaker in desired location. **Note:** All circuit breakers should be attached to chassis with torque of 30 lb.-in. (0.21 N-m).

Install main circuit breaker and back fed main breakers bolt onto chassis. For non-chassis mounted main breakers for Size D (D2DD or EXDD), install interphase barriers between terminal lugs (both line and load sides) of main breaker and bolt to dedicated location (**Note:** Ensure mylar insulator is attached between main breaker and mounting plate). Replacement interphase barriers part number: Cutler-Hammer: IPB1.

- Make sure to attach wire or approved ring terminals with appropriate torque value listed on circuit breaker or provided by manufacturer.
- Note:** For 15 amp and 20 amp breakers used in factory sealed panel Sizes B, C and D with 3-phase 4-wire (480Y/277 volts) systems, or for 15 amp and 20 amp breakers used in non-factory sealed panels using wire sizes greater than #10 AWG, an approved method of wire splicing must be used to splice down to sized wire. Alternatively, the breakers below can be purchased to accommodate #8 AWG sized wire. For ambient compensated (50°C), include "V" at end of part number.

Part number	Poles	Amperage
GHB1015C	1	15
GHB2015C	2	15
GHB3015C	3	15
GHB1020C	1	20
GHB2020C	2	20
GHB3020C	3	20

- Remove actuator strap from actuator plate assembly.
- Install and align slider in desired location and securely reattach actuator strap.
- Reattach actuator plate assembly to chassis, close cover and tighten four (4) cover bolts. Test handles in ON, OFF and RESET position. Operator should freely move to ON position. Close cover, making sure the flame path is clean and bolts are tightened to a torque of 40-45 lbs.-ft. (19.2-21.5 N-m). Refer to Step 6 on page 4 for alternate feed product.
- Following proper installation instructions in prior sections, attach conduit and pull wire to desired terminal block.
- Make sure all loose wires are secured and will not be pinched between cover and body when closing enclosure.
- Make sure all screws and bolts are tightened to the appropriate torque values found in Chart 1.

### B. Adding Group B kit (EXD GB KIT)

#### ⚠ WARNING

To avoid the risk of explosion or equipment damage, do not scratch or damage flat joint flame path on either cover or body. Always clean both body and cover of dust and foreign particles prior to closing. Dirt or foreign material must not accumulate on flat joint surfaces.

#### ⚠ CAUTION

To avoid personal injury or damage to the panelboard assembly, any chassis screws removed must be securely reinstalled. These screws are required to properly support the chassis bus bars.

- De-energize panel, open circuit breaker enclosure and make sure bolts are retracted in cover.
- Remove actuator plate from housing as shown below.

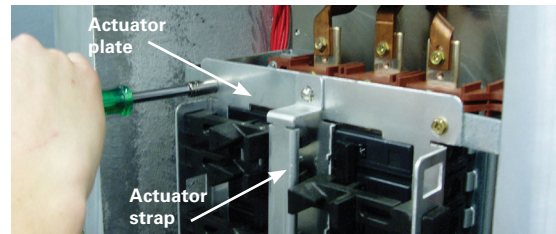

- Three (3) insulated plates are provided in the EXD GB kit. Plates marked "end" in image below would be used on top side and bottom side when chassis is full with breakers. When not completely filled, plate marked "between" must be used.

Insert insulating plates, one at the top of the chassis, and the second below the bottom-most breaker position per the following picture.

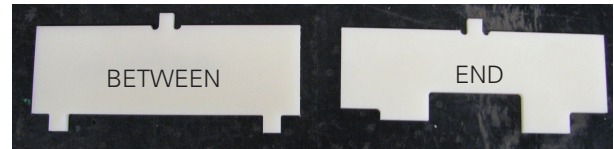

**Note:** Adjusting actuator plate mounting bracket may be necessary to securely position insulating plate.

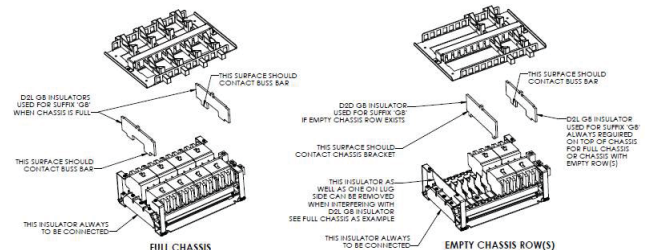

When removed to install GB insulator on either end of chassis, chassis screws must be reinstalled and securely tightened.



Black insulator facing downward must be reinstalled.

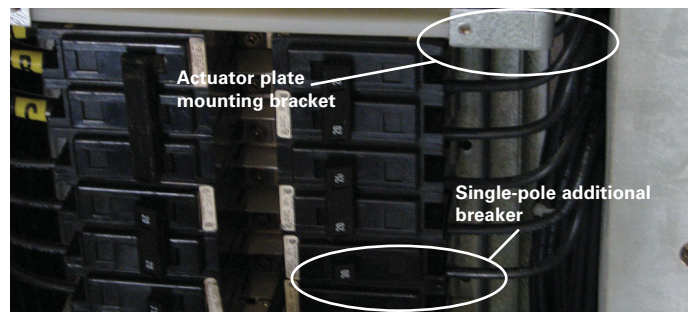

## NOTE

There should not be any empty breaker spaces between upper and lower GB insulator plates.

- Reinstall actuator plate and be sure the insulating plates protrude through the actuator plate.
- Close enclosure cover, making sure that bolts are retracted to prevent scratches or damage of the flange surface. Using only the bolts provided with the enclosure, tighten all bolts to 40-45 lbs.-ft. (19.2-21.5 N-m).
- Make sure all screws and bolts are tightened to the appropriate torque values found in Chart 1.

### C. Adding an operator handle cover

- Mount operator cover on lockout plates while securely holding in place.
- Securely fasten operator cover hinge to lockout plate with hinge screws and nuts provided.

### D. Adding a terminal housing mounting bracket (EXDA MTG KIT; D2DS MTG KIT)

- Locate bracket on existing terminal housing mounting feet.
- Fasten bracket to mounting feet using hardware provided.

## CAUTION

To avoid personal injury or damage to the panelboard assembly, always securely fasten the cast aluminum breaker housing before securing the terminal housing.

- Secure bracket to desired mounting position.

### E. Adding a gland plate hub kit

**Note:** With a D2DS style panel, the following gland plate hub kits are available:

D2D HUB2 KIT	(1) 3", (12) 3/4"
D2D HUB3 KIT	(1) 3", (12) 1"
D2D HUB5 KIT	(1) 3", (12) 1-1/2"
D2D HUB0 KIT	No entries for replacement of damaged plates

## CAUTION

To avoid the risk of water ingress, when removing the gland plates, do not damage or compromise the gasket. Contact Crouse-Hinds for replacement gland plates if damaged.

- Remove existing gland plates from terminal housing.
- Install Myers hubs to new gland plate wrench tight.
- Install gland plate kit and tighten screws to the appropriate torque values found in Chart 1.

## NOTE

Eaton's Crouse-Hinds Division recommends attaching side gland plates with entries adjacent to the center gland plate.

## GENERAL MAINTENANCE

### WARNING

To avoid risk of explosion or equipment damage, do not scratch or damage flat joint flame path on either cover or body. Always clean both body and cover of dust and foreign particles prior to closing. Dirt or foreign material must not accumulate on flat joint surfaces.

### WARNING

To avoid personnel injury or damage to equipment, disconnect all power upstream from panel prior to opening enclosure. Failure to do so could result in personnel injury or damage to equipment.

- Frequent inspection should be made. A schedule for maintenance checks should be determined by the environment and frequency of use. It is recommended that it should be at least once a year.
- Eaton's Crouse-Hinds Division recommends an Electrical Preventative Maintenance Program as described in the National Fire Protection Association Bulletin NFPA 70B: Recommended Practice for Electrical Equipment Maintenance ([www.nfpa.org](http://www.nfpa.org)).
- It is recommended that GFI and EPD breakers be tested monthly.
- Perform visual, electrical and mechanical checks on all components on a regular basis.
  - Visually check for undue heating evidenced by discoloration of wires or other components, damaged or worn parts, or leakage evidenced by water or corrosion in the interior.
  - Electrically check to make sure that all connections are clean and tight.
  - Mechanically check that all parts are properly assembled and operating mechanisms move freely.
  - When checking torque on main lugs, it may be necessary to remove the actuator plate assembly to get access to the screws on the main lugs or branch circuit breakers.
  - Ensure all appropriate insulation inside panel is properly intact.
- A factory Watguard desiccant pack has been provided. The purpose of this desiccant is to absorb and remove water on contact or from the atmosphere and protect the enclosed equipment from damage. The desiccant packet will expand 3 to 4 times its original size. Desiccant should be checked and replaced at regular equipment service intervals or every 3 to 6 months.

**For replacement desiccant packets,** order Cat. # WG22 (protects 2-3 cubic feet of air space and is recommended for terminal housings); or Cat. # WG33 (protects 4 to 5 feet of air space and is recommended for circuit breaker housings).

Watguard is non-toxic, emits no fumes, and generates no heat during use. No gloves, masks or special clothing is required to handle this product.
- Make sure all cover bolts are fully retracted into cover before closing cover on body. Close cover and start cover bolt threads by hand. Torque all cover bolts securely to 40-45 ft. lbs. (19.2-21.5 N-m).

All statements, technical information and recommendations contained herein are based on information and tests we believe to be reliable. The accuracy or completeness thereof are not guaranteed. In accordance with Eaton's Crouse-Hinds Division's "Terms and Conditions of Sale," and since conditions of use are outside our control, the purchaser should determine the suitability of the product for the intended use and assumes all risk and liability whatsoever in connection therewith.