

N2RS SERIES INDUSTRIAL CONTROL SWITCHES FOR CLASS I, DIVISION 2 AREAS

Installation & Maintenance Information

IF 1336

SAVE THESE INSTRUCTIONS FOR FUTURE REFERENCE

APPLICATIONS

N2RS Series enclosed Heavy Duty Industrial Control Switches are used as a means of disconnecting power from motors, lighting and power circuits. The N2RS is available with a 60 or 100 amp RSWP series switch. The switch is factory sealed making the N2RS suitable for use in Class I, Division 2, Group B, C and D hazardous environments. The enclosure is made of Krydon material and is suitable for wet and corrosive environments, indoors and outdoors. The enclosure is rated for NEMA 3, 4X, 7 (Div.2)B,C,D and 12 environmental suitability.

ENCLOSURE DISASSEMBLY

WARNING

To avoid electrical shock hazard electrical power must be turned OFF before and during installation and maintenance.

1. Place operating handle in the OFF position.
2. Loosen the cover screws.
3. Carefully remove cover and set aside.

NOTE

To help with orientation when cover is removed, the KEYHOLE SLOTS in the switch mounting plate are always at the top.

CONDUIT HUB INSTALLATION

N2RS enclosures are furnished without conduit openings. Two Crouse-Hinds NHUB type hubs are included with each N2RS enclosure. See Table A for Hub size.

CATALOG #	TABLE A	
	AMPERAGE	HUB SIZE
N2RS603	60	1 1/2"
N2RS1003	100	2 1/2"

Refer to the installation instructions furnished with conduit hub for proper installation procedure.

All machining should be done prior to installation of enclosure.

1. Locate and drill conduit hub opening then install conduit hub. While making hole in enclosure body, protect switch with a clean cloth or plastic film so particles will not enter the device. Clean all foreign material out of enclosure after hub installation.

WARNING

All hubs entering the enclosure must be properly grounded. The grounding terminal on the hub must be electrically connected to the grounding terminal on the mounting plate. All grounding must be done in accordance with the National Electrical Code and any applicable local codes to avoid hazard of electrical shock.

2. Solidly bond installed hub(s), grounding bushing(s), mounting plate and any exposed metal parts.

ENCLOSURE INSTALLATION

1. Select mounting location that will provide suitable strength and rigidity for supporting the enclosure and all contained wiring. The mounting dimensions for the four mounting feet for lag screws or mounting bolts are shown in figure 1.

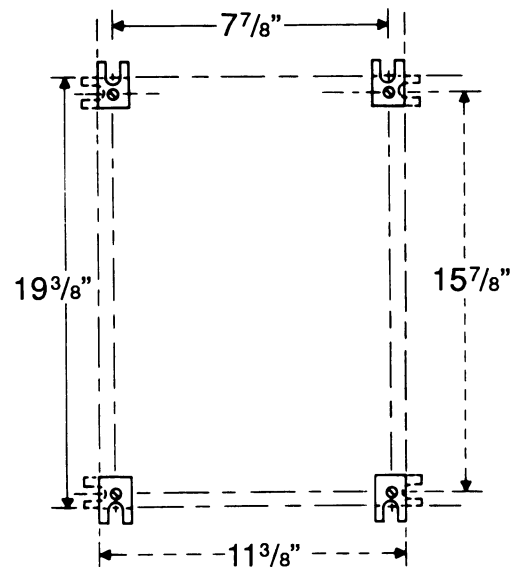

Figure 1

- Enclosure is shipped with the mounting feet stowed inwardly. Loosen the screws holding the feet and turn the feet outward to desired vertical or horizontal position. Make sure feet are seated firmly in recess before tightening down holding screws. Do not exceed 35 lb.-in. torque on mounting feet.
- Slots in mounting feet allow the use of mounting bolts up to 1/2 inch diameter, however, 3/8 inch diameter mounting bolts are recommended.
- Install flat washers under the heads of all four mounting fasteners.

CAUTION

To avoid corrosion problems use only corrosion resistant mounting hardware.

- 2. Securely fasten enclosure in desired location.
- 3. Install conduit in entrance hubs following instruction supplied with each hub.

WIRING

CAUTION

When wiring to switch terminal, be sure to insert the wire between the bearing plate of the terminal and the base of the lug. The screw must bear on the bearing plate and **NOT** directly on the wire.

- 1. Pull all phase conductors and grounding conductors into enclosure and make connections to the line pressure connector terminations on the switch following the wiring pattern established for your system (see Table B for wire size information). Connect grounding conductors.

TABLE B

Amps	Wire Size	Torque
30/60	14 - 8 AWG	40 lb.- in.
30/60	6 - 4 AWG	45 lb.- in.
100	1/0 - 2 AWG	45 lb. - in.
100	6 - 4 AWG	50 lb.- in.

- 2. Pull all load side conductors into enclosure and make connections to the load pressure connector terminations on the switch following the wiring pattern established for your system. Connect grounding conductors.
- 3. Connect auxiliary contact conductors (if applicable) to the small contact block terminals.
- 4. Test wiring for correctness with continuity checks and for unwanted grounds with insulation resistance tester. Be certain all exposed metal parts are grounded.

WARNING

Proper grounding of systems and circuit conductors is required to limit hazardous voltages caused by lightning, line surges or unintentional contact with higher voltage lines and to stabilize the voltage to ground during normal operation. All conductive materials that enclose the electrical conductors or attached equipment or forming part of such equipment must be grounded. A permanent conducting connection must be made between all such equipment and the earth.

- 5. Position operating handle on cover in OFF position and replace cover. Tighten cover screws to screw driver tight. Do not overtighten.

MAINTENANCE

WARNING

To avoid electrical shock hazard power must be turned OFF before and during installation and maintenance.

- 1. Frequent inspection should be made. A schedule for maintenance checks should be determined by the environment and frequency of use. It is recommended that it should be at least once a year. We recommend an Electrical Preventative Maintenance program as described in the National Fire Protection Association Bulletin NFPA No. 70B.
- 2. Perform visual, electrical and mechanical checks on all components on a regular basis:
 - Visually check for undue heating evidenced by discoloration of wires or other components, damaged or worn parts, leakage evidenced by water or corrosion in the interior.
 - Electrically check to make sure that all connections are clean and tight.
 - Mechanically check that all parts are properly assembled, and operating handle moves freely.

REPLACEMENT PARTS:

30/60 Amp Switch	RSWP603
100 Amp Switch	RSWP1003
Operating Handle w/switch adapter assembly	N2RS-KIT1
Auxiliary Switch	ESWP126

All statements, technical information and recommendations contained herein are based on information and tests we believe to be reliable. The accuracy or completeness thereof are not guaranteed. In accordance with Crouse-Hinds "Terms and Conditions of Sale", and since conditions of use are outside our control, the purchaser should determine the suitability of the product for his intended use and assumes all risk and liability whatsoever in connection therewith.