



Power Panelboards EPL and D2L Series Breaker Actuator Kits

SAVE THESE INSTRUCTIONS
FOR FUTURE REFERENCE

IF1328

Installation & Maintenance Information

APPLICATION

EPL and D2L Series panelboards provide a centrally controlled switching system and short circuit protection for feeder or branch circuits to control lighting, appliance, heat tracing, ground fault interruption and similar circuits.

Breaker actuator kits are used to change the configuration of an existing panelboard. EPL K1 and EPL K3 kits provide breaker operators while EPL K2 kits provide operator plugs. Changing present

breaker pole combinations is solved by choosing the appropriate kit.

Panelboards should be installed, inspected, maintained, and operated by qualified and competent personnel. Read entire instructions before starting installation of this product. Contact your Crouse-Hinds Sales Representative, Crouse-Hinds Customer Service or your Crouse-Hinds Distributor if you have any questions.

INSTALLATION

WARNING

To provide protection against fire or shock hazard, the electrical power must be OFF before and during installation and maintenance.

OPENING COVER

Make sure all cover bolts are fully retracted into the cover before attempting to open or close the cover.

When bolts are disengaged from the body flange threads, the bolts will withdraw and be held in this position by the spring and washer under the bolt heads.

After all bolts are fully disengaged, firmly grasp the bottom and right side of the cover and carefully swing cover aside. To prevent damage to the ground joint surface, avoid striking cover, or devices in cover, on neighboring enclosures or structures.

CAUTION

Hammers or prying tools must not be allowed to damage the flat joint surfaces. Do not handle cover roughly, or, if removed, do not place it on surfaces that might damage or scratch the flat ground joint surfaces.

Pull any necessary additional wires into panelboard junction box making sure that they are long enough to make the required connections. Make connections per Figure 1 of either one or three phase circuits. For optional wiring systems, refer to IF1316 located on the inside cover of terminal housing.

Test wiring for correctness with continuity checks for unwanted grounds with an insulation resistance tester.

With breakers installed in new panelboard configuration, determine the location of breaker operators to be added and circuit positions to be plugged.

ADDING BREAKER OPERATORS

1. Remove plug from opening.
2. Apply a small amount of non-petroleum based lubricant, such as Crouse-Hinds STL or HTL to operating bearing threads.
3. Thread in operating bearing from the outside of the panel until the bearing bottoms out (see figure 2).
4. Slide spring over square end of operating shaft until it seats against roll pin.
5. Thread shaft from the inside of enclosure thru operating bearing until O-ring groove is exposed.
6. Place the O-ring onto shaft groove with a touch of white grease.

continued on back

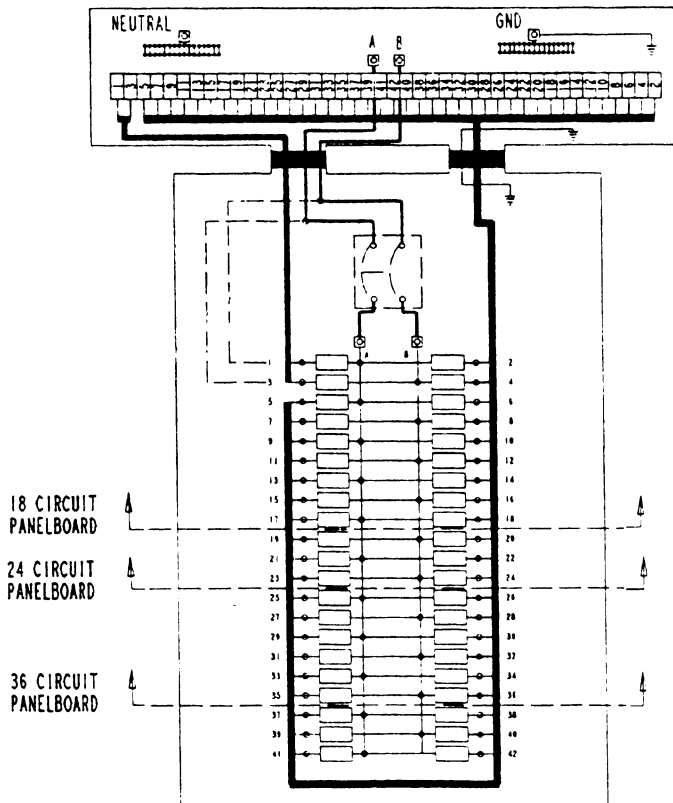

Single Phase Circuit Wiring Diagram

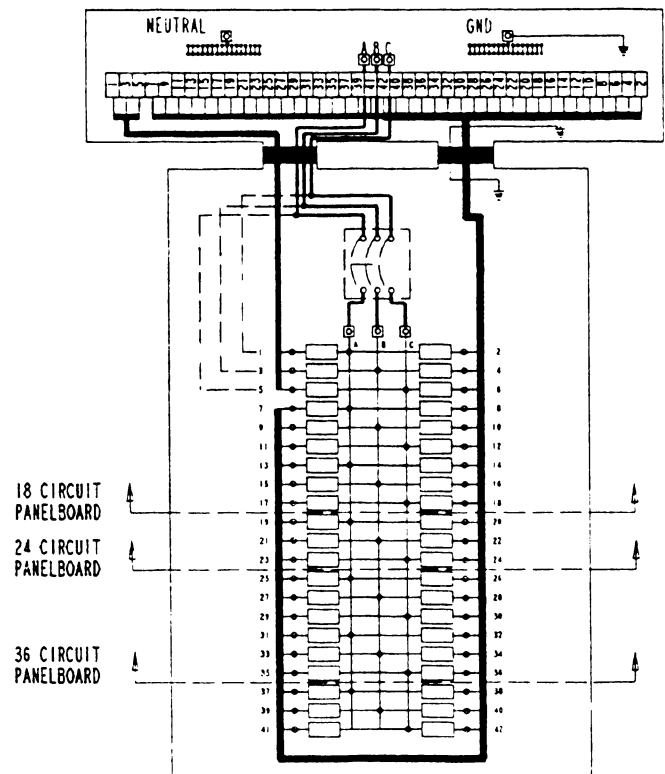
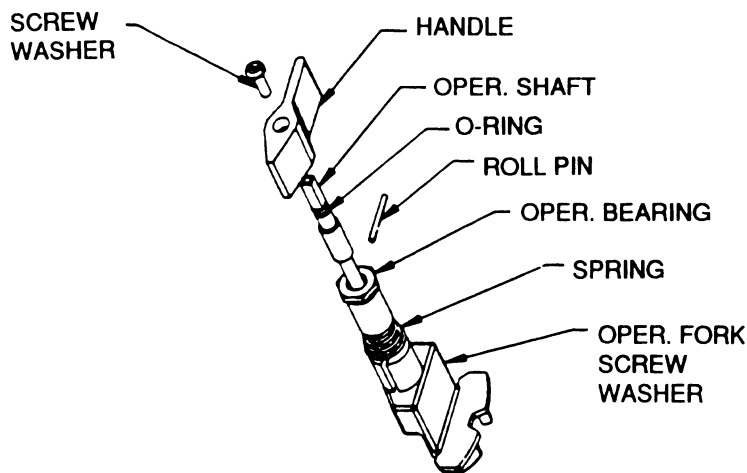

Figure 1

Three Phase Circuit Wiring Diagram

7. After installation of O-ring, back off shaft one or two turns so that the O-ring is not exposed. The square section of the shaft should be just above the bearing.
8. The roll pin should be parallel to the bottom of the enclosure.
9. Install the operating fork sliding roll pin into fork groove. Secure with lock washer and screw. Fork should be facing bottom of panel (see figure 3).
10. Install operating handle with counter bore facing up and shorter end pointing towards the center of the breaker enclosure using the lock washer and screw provided.

NOTE: For 2 and 3 pole breaker actuators two long roll pins (provided) must be installed into the pre-drilled holes in the back of the breaker housing cover. This will prevent the actuators from rotating 360 degrees (see figure 3).



Typical Branch Circuit Breaker Handle Assembly
Figure 2

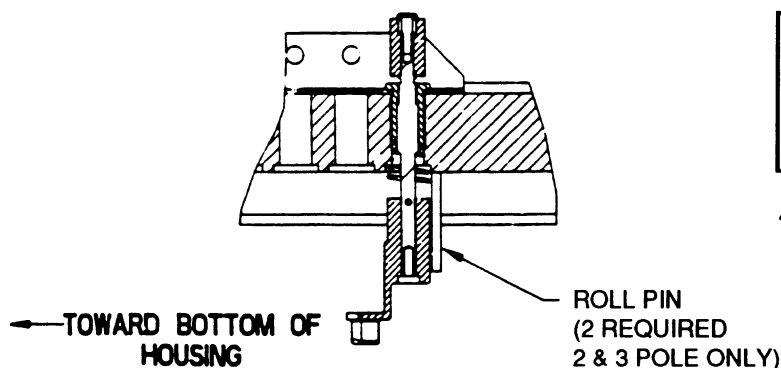

Fork Stop Assembly
Figure 3

ADDING PLUGS

Remove breaker operator assembly and bearing and using a non-petroleum based thread lubricant, thread in plug until it is tight against face plate. Install two roll pins where necessary to limit over travel of adjacent operator forks (see figure 3).

CAUTION

Clean dirt or foreign material from both flange surfaces of body and cover before closing.

Securely tighten all cover bolts. Use only bolts supplied with the panelboard. Start cover bolt threads by hand then torque all cover bolts to 40-45 ft. lbs..

MAINTENANCE

WARNING

Always disconnect primary power source before opening enclosure for inspection or service.

1. Frequent inspection should be made. A schedule for maintenance check should be determined by the environment and frequency of use. It is recommended that it should be at least once a year.
2. Perform visual, electrical and mechanical checks on all components on a regular basis.
 - Visually check for undue heating evidenced by discoloration of wires or other components, damaged or worn parts, or leakage evidenced by water or corrosion in the interior.
 - Electrically check to make sure that all connections are clean and tight.
 - Mechanically check that all parts are properly assembled and operating mechanisms move freely.
3. Make sure all cover bolts are fully retracted into cover before closing cover on body. Close cover and start cover bolt threads by hand. Torque all cover bolts securely to 40-45 ft. lbs.

CAUTION

Clean both ground joint surfaces of body and cover before closing. Dirt or foreign material must not accumulate on flat ground joint surfaces. Surfaces must seat fully against each other to provide a proper explosionproof seal.

4. We recommend an Electrical Preventive Maintenance program as described in the National Fire Protection Association Bulletin NFPA No. 70B.

All statements, technical information and recommendations contained herein are based on information and tests we believe to be reliable. The accuracy or completeness thereof are not guaranteed. In accordance with Crouse-Hinds "Terms and Conditions of Sale", and since conditions of use are outside our control, the purchaser should determine the suitability of the product for his intended use and assumes all risk and liability whatsoever in connection therewith.