



Grounding Indicator • EGL Series - Model M3 Interior Replacement Kit EGL210-R1-M3 Installation & Maintenance Information

IF 1241

SAVE THESE INSTRUCTIONS FOR FUTURE REFERENCE

APPLICATION

EGL Grounding Indicator Interior Replacement Kits are designed for field replacement of damaged or defective interior assemblies, for EGL Series - Model M3 Grounding Indicators.

EGL Interior Replacement Kits should be installed, inspected and serviced by qualified and competent personnel, in compliance with the latest edition of the National Electrical Code.

Read entire instructions before starting installation of this product. Contact your Crouse-Hinds Sales Representative, Sales/Service in Syracuse, or your Crouse-Hinds Distributor, if you have any questions.

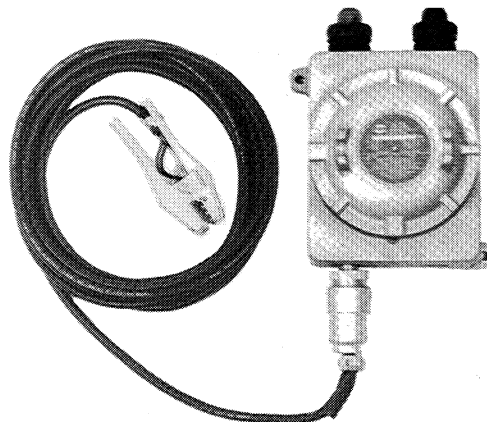

STOP:

Before proceeding, identify the color code of your replacement interior. If you have a blue label, follow the first set of instructions. If the label is orange, follow the second set.

INTERIOR INSTALLATION FOR BLUE LABEL

WARNING

To provide protection against fire or shock hazard, the electrical power must be turned **OFF** to the grounding indicator and auxiliary contacts, before and during installation and maintenance of this product.

WARNING

Be sure there are no wires beneath the interior assembly during installation. Trapped wires may have insulation damaged when freed or when the interior assembly is fastened in place.

1. Remove existing interior components including mounting plate. When removing interior, mark the two EBY wires that are under the ground lugs as "ground" and mark the other black wire from the EBY to the circuit assembly as "#6" for wiring diagram A.
2. Discard old interior.
3. On new interior, disconnect the wire from terminal block #3.
4. Remove screws holding the relay on the terminal block/relay bracket and set aside. Remove the two screws holding the terminal block/relay bracket on the back plate and set aside.
5. Remove the barrier cover plate that holds the intrinsically safe barrier from the back plate.

6. Remove the nut holding the ground lug from the back plate and discard.
7. Mount the back plate and ground lugs using four 1/4" screws as shown in the illustration.

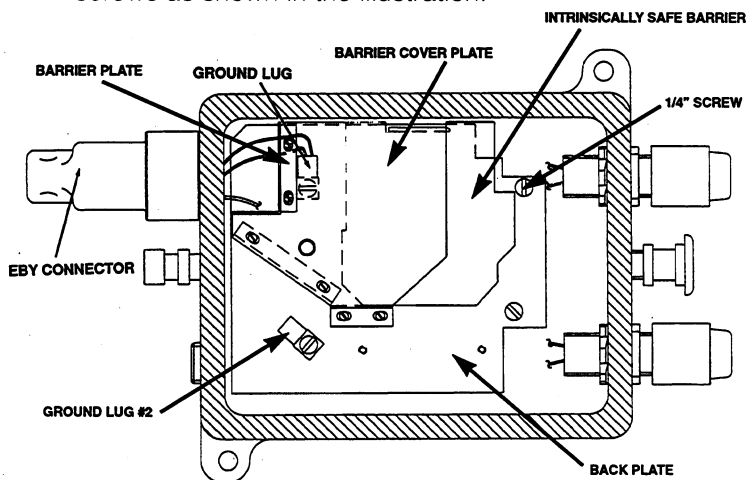

EGL INTERIOR MOUNTING FOR BLUE LABEL

Note: Refer to wiring diagram A on pg. 2 for the following:

8. Connect barrier wires #1 and #4 and the EBY leads marked "ground" to the ground lug. Tighten the ground lug.
9. Insure that the other two EBY leads marked "ground" that were under the ground lug on the old interior are under the new ground lug.

10. Holding the barrier vertically, connect the EBY black lead marked "#6" and barrier wire #5 on the barrier using a wire nut (supplied).
11. Connect the two white wires from the pilot light to barrier #13 using a wire nut (supplied).
12. Connect the black lead from the green pilot light along with the relay coil wire to barrier #12 using a wire nut (supplied).
13. Insert the black wire from the red pilot light along with the jumper into barrier #11 using a wire nut (supplied).
14. Lay the barrier down under the barrier plate and bring the lead from terminal block #3 through the hole with the nylon bushing. Ensure that the tab on the back of the barrier plate slides into the din rail mount on the barrier.
15. Ensuring that the ground connections to the EBY are under the ground lug, mount the barrier assembly against the lower left corner of the enclosure.
16. Mount the relay, coil block, and terminal block/relay bracket onto the mounting plate. Tighten the screws holding the relay on the terminal block/relay bracket.
17. Reconnect terminal block wire #3.
18. Reconnect the field wiring per IF1178.
19. Verify that the unit properly performs by energizing the unit. Red light should be on when no item is clamped. Green light should come on when the clamp is attached to an item to be grounded (Do not test on a grounded item).

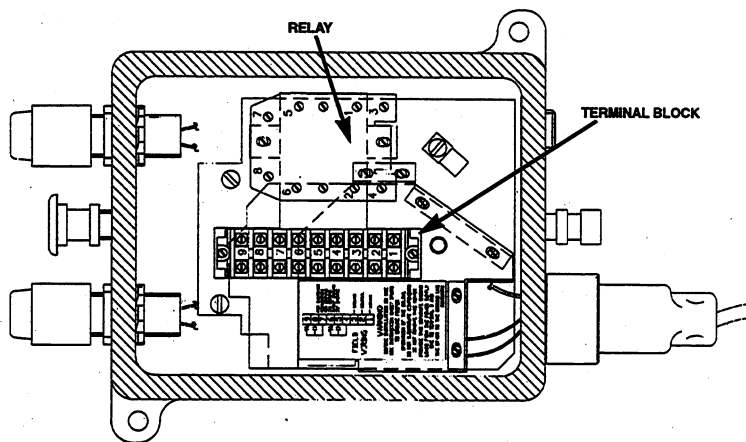

EGL INTERIOR MOUNTING FOR BLUE LABEL

MAINTENANCE

WARNING

Always disconnect primary power source **before** opening enclosure for inspection or service.

1. Frequent inspection should be made. A schedule for maintenance check should be determined by the environment and frequency of use. It is recommended that it should be at least once a year.
2. Perform visual, electrical and mechanical checks on all components on a regular basis.
 - Visually check for undue heating evidenced by discoloration of wires or other components, damaged parts, or leakage evidenced by water or corrosion in the interior.
 - Electrically check to make sure that all connections are clean and tight.
 - Mechanically check that all parts are properly assembled.

CAUTION

- Before assembling any mating threads make certain that there is no dirt or other foreign material on, or in, either set of threads.
- Cover, conduit(s), and any plug(s) threads **must** be engaged properly with their mating threads and **securely** tightened.
- All threaded joints in the enclosure have been treated at the factory with Crouse-Hinds STL screw thread lubricant which acts as a lubricant and anti-seize agent. Whenever any threaded joint(s) are disassembled, the threads should be re-treated with STL and care **must** be exercised in mating threads **properly**, and **securely** tightening the threaded joints.

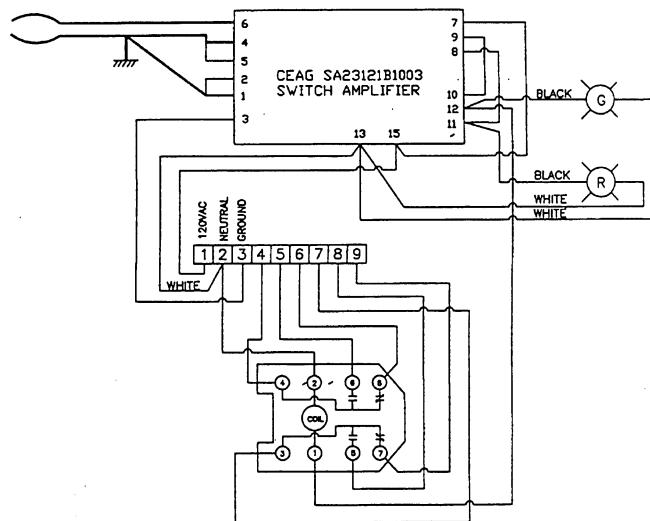

WIRING DIAGRAM A

INTERIOR INSTALLATION FOR ORANGE LABEL

WARNING

To provide protection against fire or shock hazard, the electrical power must be turned **OFF** to the grounding indicator and auxiliary contacts, before and during installation and maintenance of this product.

WARNING

Be sure there are no wires beneath the interior assembly during installation. Trapped wires may have insulation damaged when freed or when the interior assembly is fastened in place.

1. Remove existing interior components including mounting plate. When removing interior, mark the two EBY wires that are under the ground lugs as "ground" and mark the other black wire from the EBY to the circuit assembly as "#4" for wiring diagram B.
2. Discard old interior.
3. On new interior, disconnect the wire from terminal block #3.
4. Remove screws holding the relay on the terminal block/relay bracket and set aside. Remove the two screws holding the terminal block/relay bracket on the back plate and set aside.
5. Remove the barrier cover plate that holds the intrinsically safe barrier from the back plate.
6. Remove the nut holding the ground lug from the back plate and discard.
7. Mount the back plate using three 1/4" screws as shown in the illustration.

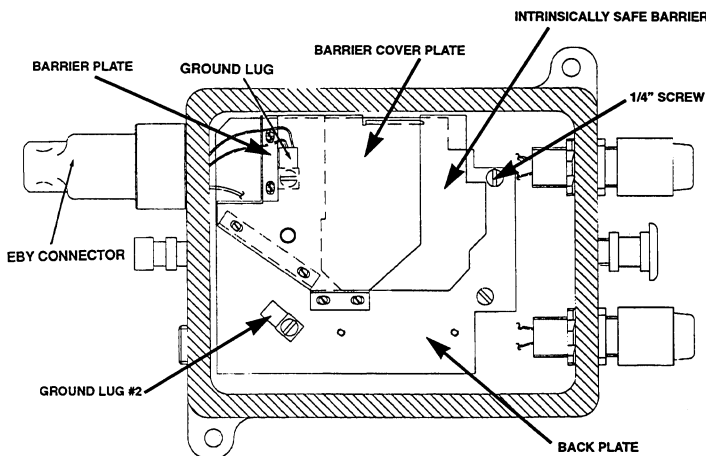

EGL INTERIOR MOUNTING FOR ORANGE LABEL

Note: Refer to wiring diagram B on pg. 4 for the following:

8. Connect barrier wires #6 and #3 and the EBY leads

marked "ground" to the ground lug. Tighten the ground lug.

9. Insure that the other two EBY leads marked "ground" that were under the ground lug on the old interior are under the new ground lug.
10. Holding the barrier vertically, connect the EBY black lead marked "#4" and barrier wire #5 on the barrier using a wire nut (supplied).
11. Connect the two white wires from the pilot light to barrier #13 using a wire nut (supplied).
12. Connect the black lead from the green pilot light along with the relay coil wire to barrier #12 using a wire nut (supplied).
13. Insert the black wire from the red pilot light along with the jumper into barrier #11 using a wire nut (supplied).
14. Lay the barrier down under the barrier plate and bring the lead from terminal block #3 through the hole with the nylon bushing. Ensure that the tab on the back of the barrier plate slides into the din rail mount on the barrier.
15. Ensuring that the ground connections to the EBY are under the ground lug, mount the barrier assembly against the lower left corner of the enclosure.
16. Mount the relay, coil block, and terminal block/relay bracket onto the mounting plate. Tighten the screws holding the relay on the terminal block/relay bracket.
17. Reconnect terminal block wire #3.
18. Reconnect the field wiring per IF1178.
19. Verify that the unit properly performs by energizing the unit. Red light should be on when no item is clamped. Green light should come on when the clamp is attached to an item to be grounded (Do not test on a grounded item).

CAUTION

- Before assembling any mating threads make certain that there is no dirt or other foreign material on, or in, either set of threads.
- Cover, conduit(s), and any plug(s) threads **must** be engaged properly with their mating threads and **securely** tightened.
- All threaded joints in the enclosure have been treated at the factory with Crouse-Hinds STL screw thread lubricant which acts as a lubricant and anti-seize agent. Whenever any threaded joint(s) are disassembled, the threads should be re-treated with STL and care **must** be exercised in mating threads **properly**, and **securely** tightening the threaded joints.

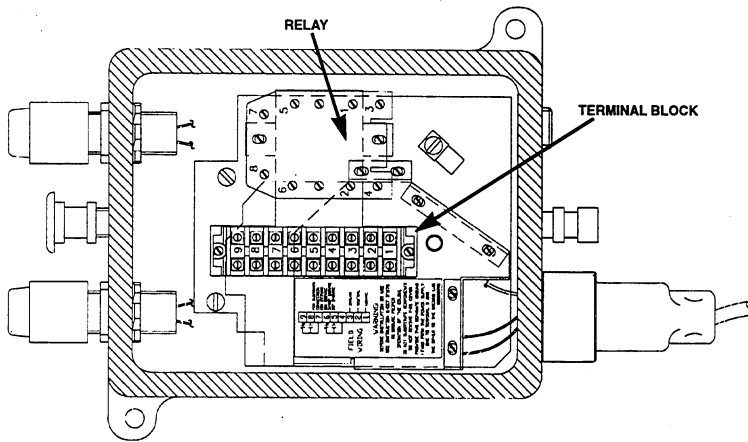

EGL INTERIOR MOUNTING FOR ORANGE LABEL

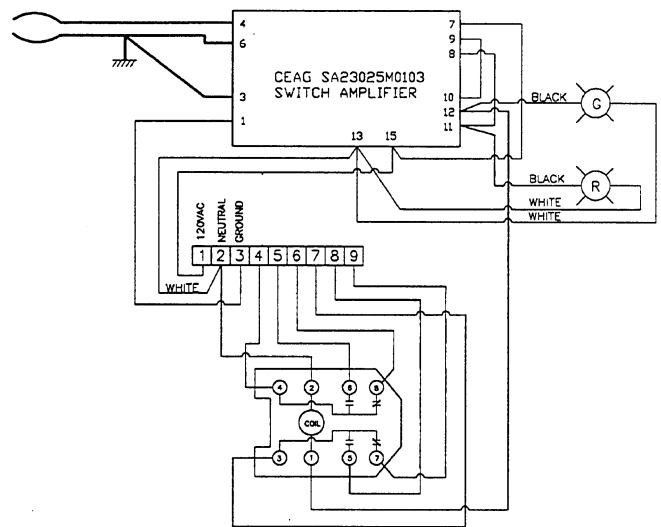

WIRING DIAGRAM B FOR ORANGE LABEL

MAINTENANCE

WARNING

Always disconnect primary power source **before** opening enclosure for inspection or service.

1. Frequent inspection should be made. A schedule for maintenance check should be determined by the environment and frequency of use. It is recommended that it should be at least once a year.
2. Perform visual, electrical and mechanical checks on all components on a regular basis.
 - Visually check for undue heating evidenced by discoloration of wires or other components, damaged parts, or leakage evidenced by water or corrosion in the interior.
 - Electrically check to make sure that all connections are clean and tight.
 - Mechanically check that all parts are properly assembled.

All statements, technical information and recommendations contained herein are based on information and tests we believe to be reliable. The accuracy or completeness thereof are not guaranteed. In accordance with Crouse-Hinds "Terms and Conditions of Sale", and since conditions of use are outside our control, the purchaser should determine the suitability of the product for his intended use and assumes all risk and liability whatsoever in connection therewith.