

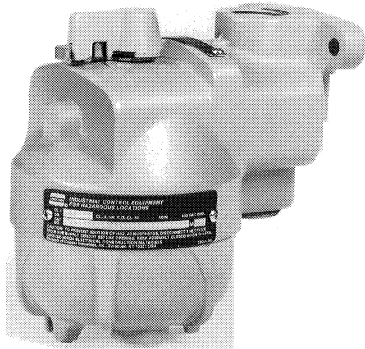

OAC Series, Model M90 Selector Switches

Installation & Maintenance Information

APPLICATION



OAC Series Selector Switches are used in conjunction with magnetic starters or contactors for remote control of motors. OAC Series devices are used indoors or outdoors in damp, wet, or corrosive areas which are hazardous due to the presence of flammable vapors, gases, or combustible dusts.

OAC Selector Switches are suitable for use in Class I, Groups A, B, C, D; Class II, Groups E, F, G and Class III hazardous (classified) areas as defined by the National Electrical Code®.

OAC Series Selector Switches must be installed, inspected and maintained by qualified and competent personnel.

INSTALLATION

WARNING

Be sure all electrical power is turned **off** before and during installation or maintenance.

1. Select a mounting location that will provide suitable strength and rigidity for supporting the selector switch and all wiring. Figure 1 shows the mounting dimensions of the selector switch. Drill mounting holes for two 5/16 in. dia. screws (not furnished).

NOTE: Allow 2-1/2 in. clearance below selector switch for removal of cover.

CAUTION

The Class and Group the product is approved for is marked on the selector switch nameplate. Conduit sealing fittings must be installed to comply with requirements in the latest edition of the National Electrical Code, Section 501-5 and/or 502-5, and any other applicable standards, as required. All unused conduit openings must be closed with an approved plug such as the Crouse-Hinds PLG Series. Plug must engage a minimum of five full threads.

3. Unscrew cover and carefully set it aside to prevent damage to the threads. **NOTE:** All screw threads have been treated with a corrosion-resistant lubricant. Relubricate the threads with Crouse-Hinds Type STL thread lubricant when necessary.
4. Remove switch/mounting bracket assembly from housing by removing two (2) 8-32 round head screws in switch mounting bracket. Note that these screws also hold the operator mechanism.
5. Pull all control wires into enclosure, allowing wires to extend 4 inches out of cover opening. Strip insulation to expose 3/8 inch of conductor at the end of each control wire.

DIMENSIONS

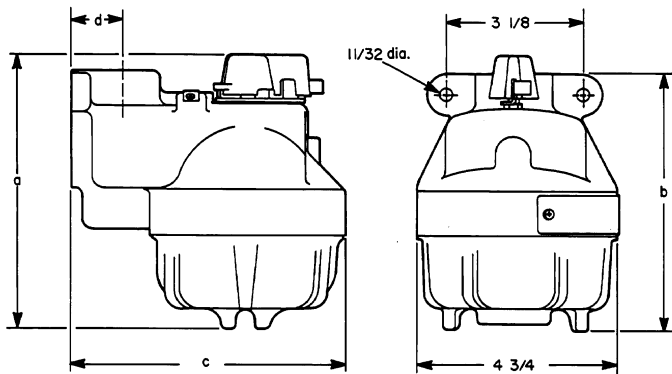

Hub Size	a	b	c	d
3/4 & 1	6-3/8	6-1/4	6-1/2	1-1/8

For Cover removal, add 2-1/2" to dimension "a".

Figure 1.

2. Securely fasten selector switch to the mounting surface. Connect assembly into conduit system. Install sealing fittings (not supplied with selector switch) as required by NEC and other applicable standards.

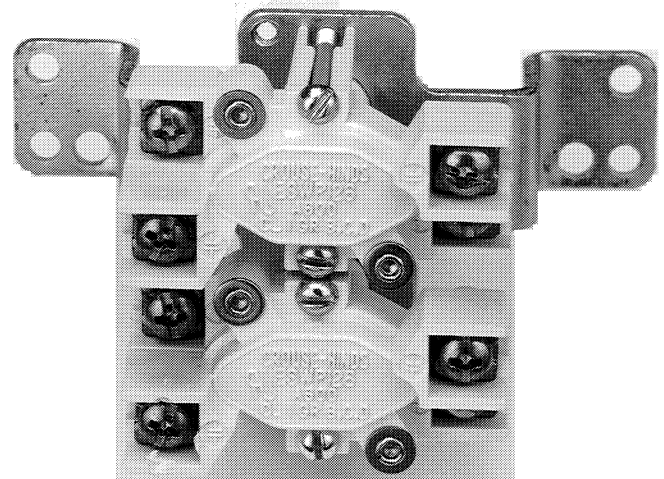

Normally Open

Normally Closed

Figure 2. Switch/Mounting Bracket Assembly

6. Make the electrical connections to screw terminals on switch assembly utilizing the wiring schemes established for your system.
7. Test wiring for correctness with continuity checks and also for unwanted grounds with an insulation resistance tester.
8. Rethread cover onto enclosure housing. Tighten cover until cover flange comes into contact with body face. Check operation of selector switch.

CAUTION

During installation, use care to prevent grit, dirt, or other foreign material from lodging on threads. If any such material settles on these threads, clean them with Stoddard solvent*, then relubricate with STL thread lubricant.

*To avoid the possibilities of an explosion, oxidation and corrosion, do not use gasoline or similar solvents.

9. Fill sealing fitting following instructions supplied with fitting.
10. Installation is complete and power source may be turned on.

MAINTENANCE

1. Frequent inspection should be made. A schedule for maintenance check should be determined by the environment and frequency of use. It is recommended that it should be at least once a year.
2. If necessary to open enclosure for inspection or service, refer to cautionary statement on nameplate before removing cover. Observe thread lubrication procedures outlined in Step 3 of Installation Information.

WARNING

Always disconnect primary power source before opening enclosure.

3. Perform visual, electrical, and mechanical checks on all components on a regular basis.

Visually check for undue heating evidenced by discoloration of wires or other components, damaged or worn parts, or leakage evidenced by water or corrosion in the interior. Electrically check to make sure that all connections are clean and tight, and that contacts in the components make or break as required.

Mechanically check that all parts are properly assembled, and operating mechanisms move freely.

SWITCH ASSEMBLY REPLACEMENT

WARNING

Be sure electrical power source to switch is turned **off**.

1. Remove cover and carefully set aside to prevent damage to threads.
2. Loosen the screws holding wires to the switch/terminals and disconnect all wires. Identify each wire for proper reassembly to replacement switch.
3. Remove two (2) 8-32 pan head screws holding switch/mounting bracket assembly to the operator mechanism. See Figure 2.
4. Replace with new switch onto mounting bracket assembly.

OAC Selector Switch	Replacement Switch Catalog No.
OAC 2471; 3471; 2472; 3473	ESWP126
OAC 2472; 3472; 2474; 3474; 2473; 3475	ESWP126 (2 req'd)

5. Reattach external power leads to switch.
 6. Check circuits for continuity and proper connections.
- NOTE:** If desired, operation may be checked using circuit tester to verify switch installation.
7. Refer to thread lubrication procedures outlined previously in Step 3 of Installation Information. Reassemble cover into body.
 8. Electrical power source may be turned ON.

All statements, technical information and recommendations contained herein are based on information and tests we believe to be reliable. The accuracy or completeness thereof are not guaranteed. In accordance with Crouse-Hinds "Terms and Conditions of Sale", and since conditions of use are outside our control, the purchaser should determine the suitability of the product for his intended use and assumes all risk and liability whatsoever in connection therewith.
