

Cl. I, Div. 1 & 2, Groups C, D Explosionproof  
 Cl. II, Div. 1, Groups E, F, G Dust-Ignitionproof  
 Cl. II, Div. 2, Groups F, G Raintight  
 Cl. III Wet Locations  
 NEMA 3, 7CD, 9EFG, 12

2C

**Applications:**

- GUSC manual motor starters are used:
- In a rigid metallic conduit system for surface mounting adjacent to or remote from the equipment being controlled
  - To prevent arcing of the enclosed switches from causing ignition of a specific hazardous atmosphere, or atmospheres, external to the enclosure
  - In industrial areas such as chemical plants, oil and gas refineries, paint and varnish manufacturing plants, gasoline bulk loading terminals, grain elevators, grain processing industries, coal processing or handling areas, or metal handling or finishing areas where the atmosphere may contain hazardous gases and/or dust
  - In non-hazardous areas where sturdy, durable enclosures are required

**Features:**

- Enclosures are of rugged metal construction with mounting lugs and taper tapped hubs with integral bushings, in a through feed or bottom feed arrangement, for connection to the rigid metallic conduit
- Cover is threaded, which provides for fast and proper assembly
- Provided with a threaded operating shaft and bushing
- Provision is made to use a padlock with 1/4" hasp, to lock the operating lever in an "ON" or "OFF" position
- Body and cover threads treated with lubricant at factory to provide raintightness

**Certifications and Compliances:**

- NEC/CEC:
  - Class I, Div. 1 & 2, Groups C, D
  - Class II, Div. 1, Groups E, F, G
  - Class II, Div. 2, Groups F, G
  - Class III
- NEMA/EEMAC: 3, 7CD, 9EFG, 12
- UL Standard: 1203
- CSA Standard: C22.2, No. 30

**Standard Materials:**

- Body – *Feraloy*<sup>®</sup> iron alloy
- Cover – copper-free aluminum
- Shaft – stainless steel
- Shaft bushing – stainless steel

**Standard Finishes:**

- *Feraloy* iron alloy – electrogalvanized and aluminum acrylic paint
- Copper-free aluminum – natural
- Stainless steel – natural

**Size Ranges:**

- Hub size – 3/4" (through feed arrangement)

**Electrical Rating Ranges:**

- See below

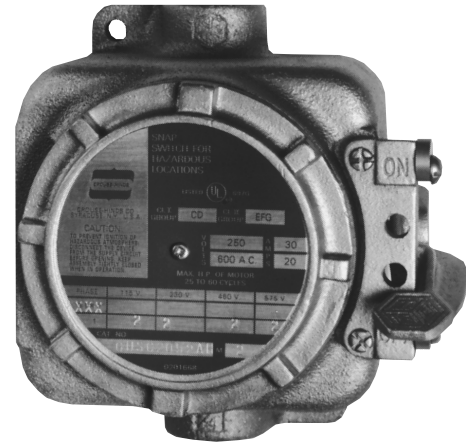

**Ordering Information:**

Cat. #	Style	Rating/Horsepower				Hub Size
		120VAC / 3 HP	240VAC / 7½ HP	480VAC / 15 HP	600VAC / 15 HP	
<b>GUSC2013-MS*</b>	3-Pole	30A	30A	30A	20A	¾"

Cat. #	Style	Rating/Horsepower				Hub Size
		120VAC / 3 HP	240VAC / 7½ HP	480VAC / 15 HP	600VAC / 20 HP	
<b>GUSC2036-MS</b>	3-Pole	40A	40A	40A	40A	¾"

\*Also rated for 30A, 250VDC, 15 HP.

**Dimensions In Inches:**

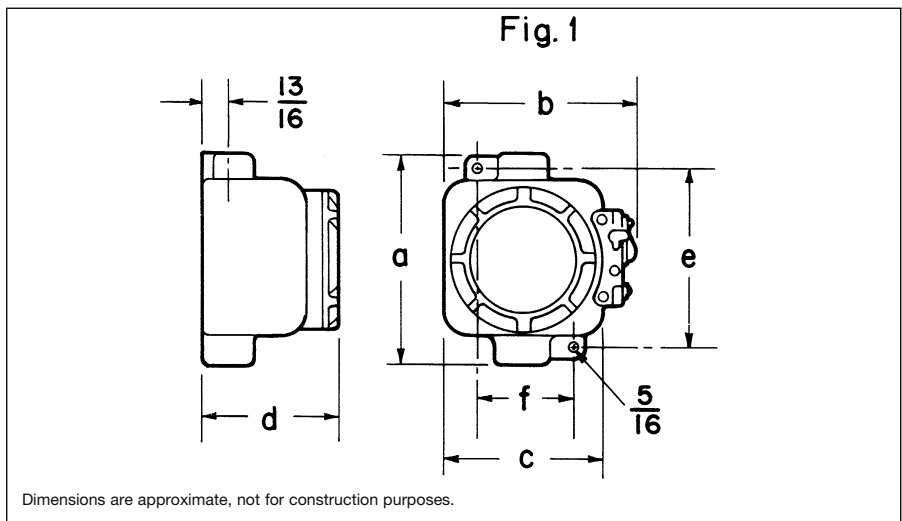

Type	Size	a	b	c	d	e	f
<b>Through Feed Hubs – Fig. 1</b>							
	3-Pole	6 <sup>3</sup> / <sub>16</sub>	6 <sup>1</sup> / <sub>16</sub>	4 <sup>7</sup> / <sub>8</sub>	4 <sup>1</sup> / <sub>8</sub>	5 <sup>5</sup> / <sub>8</sub>	3