

# EDS / EFS Series Control Stations

## EDSCM Modular Multi-Gang Control Device Bodies

Cl. I, Div. 1, Groups C, D\*  
 Cl. I, Div. 2, Groups B, C, D  
 Cl. II, Div. 1, Groups E, F, G  
 Cl. II, Div. 2, Groups F, G  
 Cl. III  
 NEMA 3, 7B (Div. 2) CD, 9EFG

Explosionproof  
 Dust-Ignitionproof  
 Raintight  
 Wet Locations

**4C**

For use with DSD device cover sub-assemblies see page 521.

### Applications:

Modular control device bodies are for surface mounting combinations of control device equipment for use in:

- Industrial areas such as chemical plants, oil and gas refineries, paint and varnish manufacturing plants, gasoline bulk loading terminals, grain elevators, grain processing industries, coal processing or handling areas where atmospheres may contain hazardous gases or dusts, and arcing of enclosed devices must not ignite the surrounding atmosphere.
- Conjunction with magnetic starters or contactors for remote control and monitoring motors.
- Manual starting and stopping of small AC or DC motors.
- Controlling and supplying energy to portable electrical devices such as motor generator sets, compressors, conveyors, portable tools, etc.

### Features:

EDSCM Modular Control Stations have many distinct advantages over multiple individual units:

- Reduce installation costs. A multi-gang device assembly can be installed in less time than several single-gang units.
- Seals not required between gangs.
- Improved appearance. No exposed conduit runs between devices.
- Lightweight. Fifteen-gang aluminum device body can be installed by one person.
- Mounting feet are provided on the top and bottom of every gang to facilitate installation.
- Two and three gang tandem bodies have 1 1/4" through feed inward horizontal hubs and 1" or 2" vertical through feed hubs. Pipe plugs are installed in one horizontal hub and both vertical hubs.
- Single-gang device bodies have 1" through feed inward horizontal hubs and 3/4" through feed vertical hubs. Pipe plugs are installed in one horizontal hub and both vertical hubs.
- All hubs are taper tapped and have integral bushings.
- Close nipples, which are used to join two or more device bodies together, are furnished with EDSCM 21, 32, 33, 62 and 63 units.
- Any combination of bodies can be joined together horizontally.

### Certifications and Compliances:

(When used with DSD device sub-assemblies)\*:

- Class I, Division 1 & 2, Groups C, D
- Class I, Division 2, Group B, C, D
- Class II, Division 1, Groups E, F, G
- Class II, Division 2, Groups F, G
- Class III
- NEMA/EEMAC: 3, 7B (Div.2) CD, 9EFG
- UL Standard: 1203
- CSA Standard: C22.2 No. 30

### Standard Materials:

- Copper-free aluminum

### Finish:

- Natural

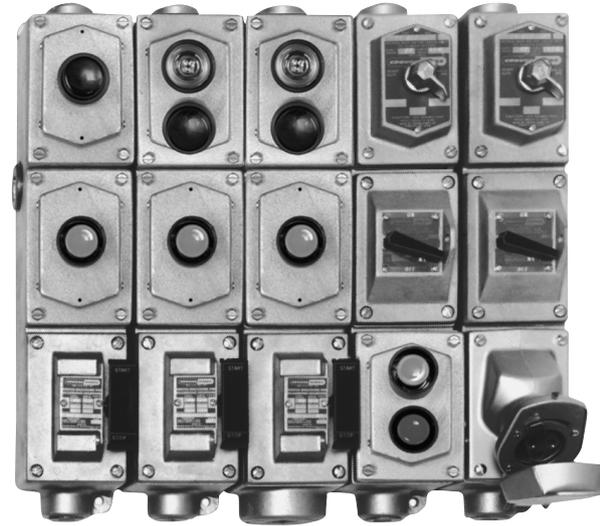

**4C**

### Ordering Information

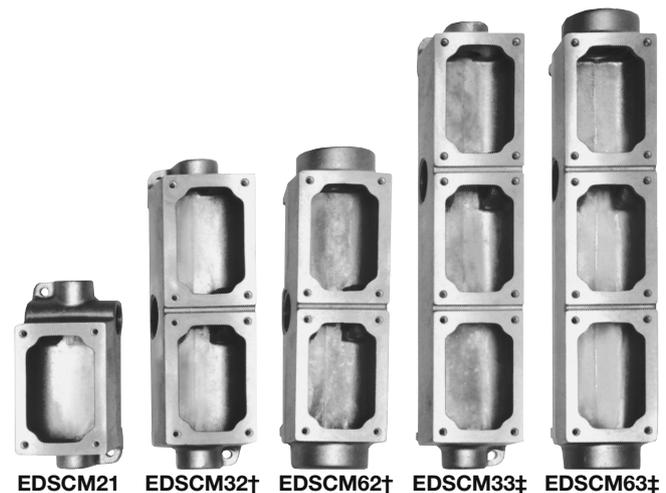

Description	Through Feed Hub Size	Cat. #
Single Gang	3/4"	EDSCM21
Tandem Two Gang	1"	EDSCM32
Tandem Two Gang	2"	EDSCM62
Tandem Three Gang	1"	EDSCM33
Tandem Three Gang	2"	EDSCM63

\* When a CPS receptacle cover device is used, the assembly meets requirements for Class I, Groups C and D areas only.

† EDSCM32 and EDSCM62 will not accept covers with S697 or S701 suffixes.

‡ Bottom gang opening will accept covers with S697 or S701 suffixes.

In Class I areas all conduit runs entering bodies must be sealed. As many as five bodies can be joined horizontally without an intervening seal.

# 4C

## EDS / EFS Series Control Stations

### EDSCM Modular Multi-Gang Control Device Bodies

Cl. I, Div. 1, Groups C, D\*  
 Cl. I, Div. 2, Groups B, C, D  
 Cl. II, Div. 1, Groups E, F, G  
 Cl. II, Div. 2, Groups F, G  
 Cl. III  
 NEMA 3, 7B (Div. 2) CD, 9EFG

Explosionproof  
 Dust-Ignitionproof  
 Raintight  
 Wet Locations

#### Dimensions In Inches:

4C

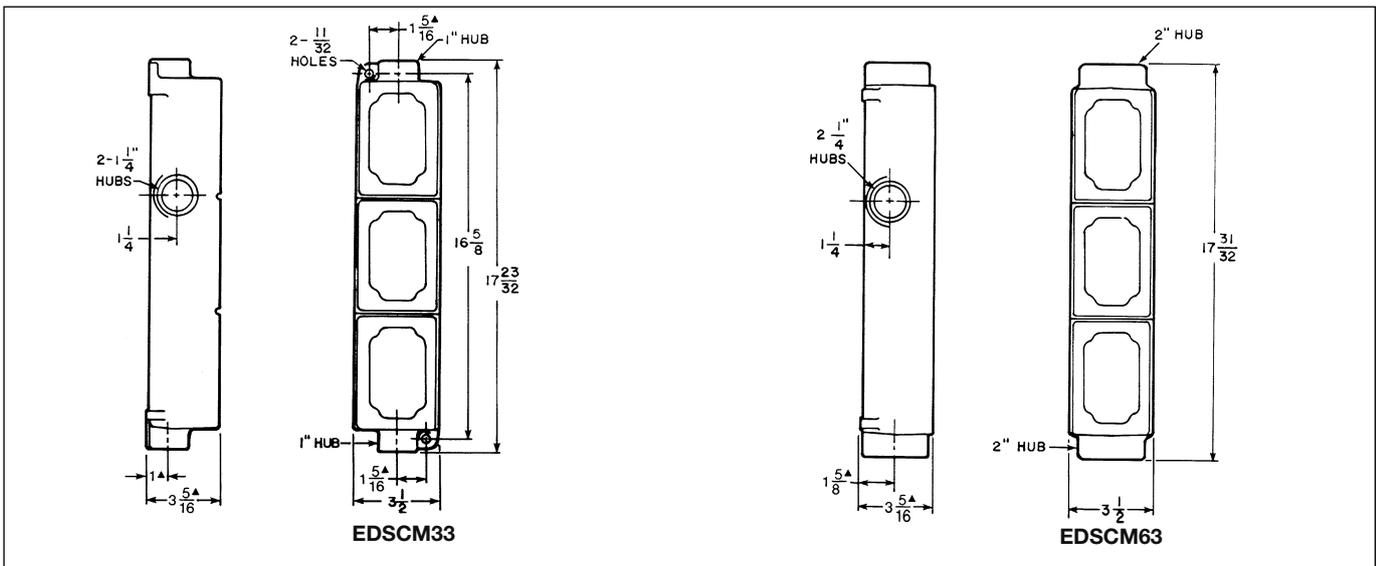
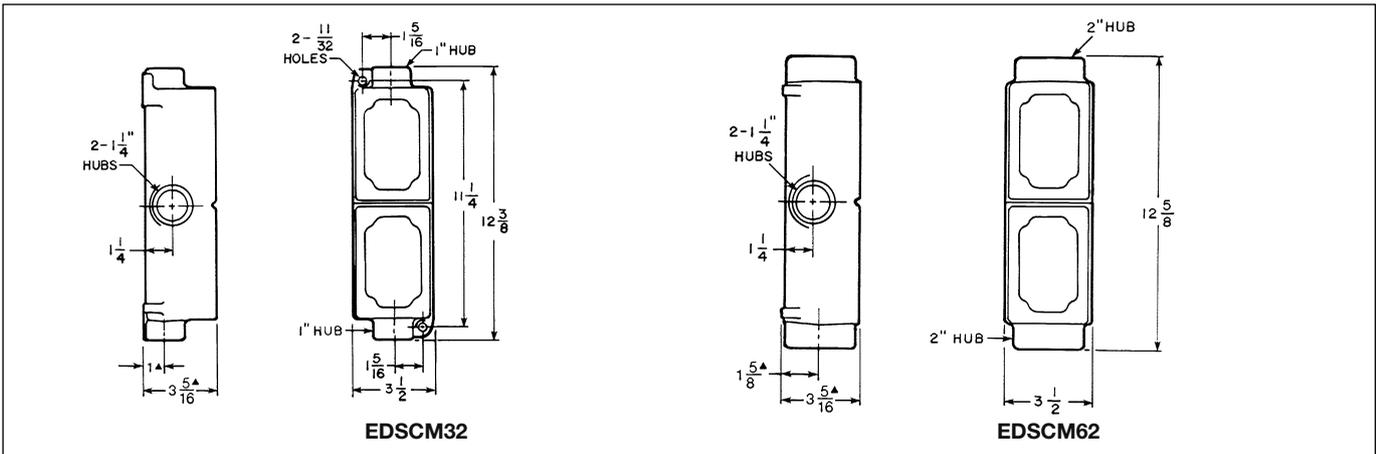
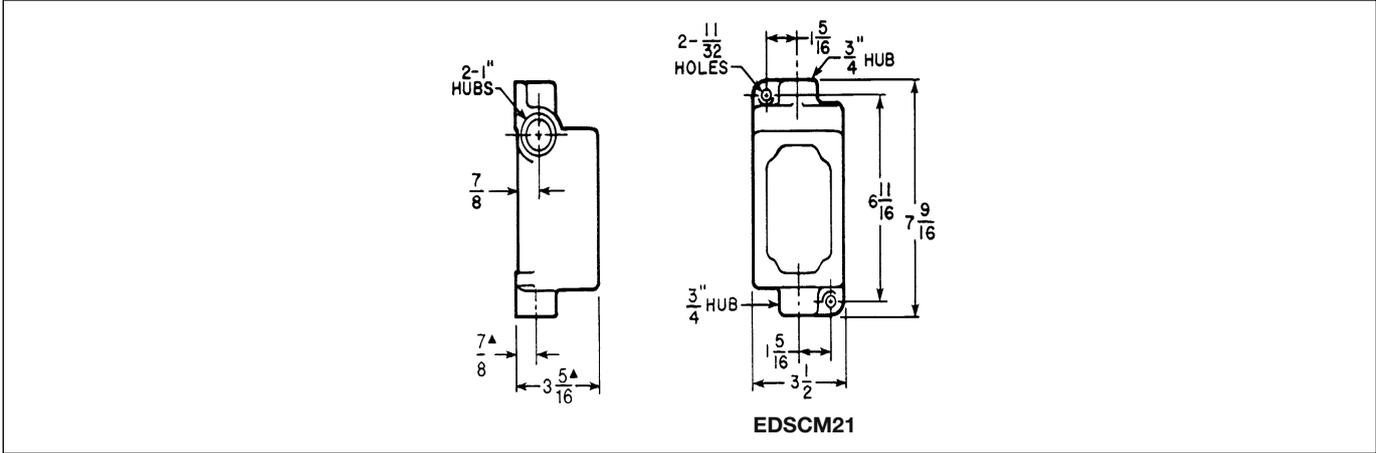

\* When a CPS receptacle cover device is used, the assembly meets requirements for Class I, Groups C and D areas only.  
 Dimensions are approximate. Not for construction purposes.