

EBMC Combination Line Starters and Enclosures

Cl. I, Div. 1 & 2, Groups B, C, D
Cl. II, Div. 1, Groups E, F, G
Cl. II, Div. 2, Groups F, G
Cl. III
NEMA 3, 3R, 4 \ddagger , 4X $\dagger\dagger$, 7BCD, 9EFG, 12

Explosionproof
Dust-ignitionproof
Raintight
Wet Locations
Watertight

1C

Applications:

EBM hinged cover motor control enclosures are used:

- For general motor control and circuit protection – indoors and outdoors – in damp, wet, dirty, dusty hazardous locations without the need for a protective shelter
- In areas where frequent washdowns are necessary or where heavy rain or water spray is prevalent
- For across-the-line starting, stopping, speed changing and reversing of polyphase AC induction motors
- To provide line disconnect means and short circuit protection
- To provide motor overload and undervoltage protection
- For service entrance, feeder or branch circuit protection for lighting, heating, appliance and motor circuits
- On switchracks or other assemblies where it's desired that motor control be centrally located

Features:

- Rugged, corrosion resistant, cast copper-free aluminum construction (less than 0.4 of 1%)
- Component operating handles located through the right side wall of the body permits visual confirmation of correct component assembly and operation
- Total compliance to the wiring end room requirements of the National Electrical Code*/Canadian Electrical Code
- Semi-clamshell enclosure design, with an external flanged ground joint between body and cover makes interior components more accessible
- Minimum enclosure-to-enclosure spacing with little interference between the opened cover and an adjacent enclosure
- Stainless steel hinges allow the cover to swing well out of the way
- Stainless steel, quick release, captive, hex head cover bolts. Stainless steel springs provide clear indication cover bolts are fully retracted from body
- Versatile, internal operating mechanisms allow for field adjustment to accommodate popular manufacturers' starters and breakers
- Simple, straightforward installation of breaker and starter on pre-drilled mounting plate within enclosure. Mounting plate also field removable.
- Circuit breaker motor circuit protector external operating handle can be padlocked in either "ON" or "OFF" positions
- Neoprene cover gasket permanently attached to the cover seals out moisture
- Bodies have top and bottom drilled and tapped entrances for power conduits plus one at the bottom for control conduit. Removable reducers are supplied, as standard, to accommodate smaller size conduits. All conduit entrances are plugged.
- Tap-on mounting feet
- Optional EMPS control devices may be added to enclosure cover
- Steel bracket for lifting larger enclosures during installation supplied as standard

*National Electrical Code is a Registered Trademark of the National Fire Protection Association.

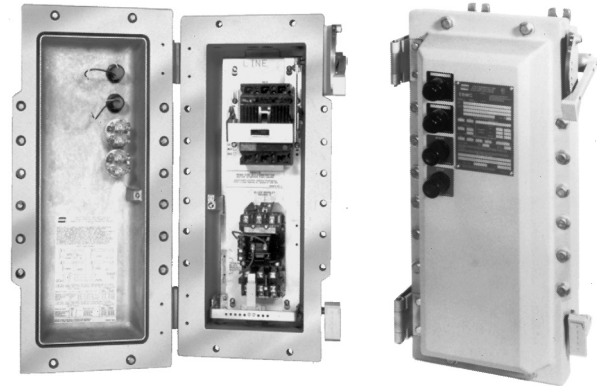

Interior components are readily accessible with ample end room for wiring

Side operators leave cover free for control options

Certifications and Compliances:

- NEC/CEC:
 - Class I, Division 1 & 2, Groups B, C, D
 - Class II, Division 1, Groups E, F, G
 - Class II, Division 2, Groups F, G
 - Class III
- UL Standards UL1203 – Hazardous (Classified) Locations
- UL Subject 2062 - High AIC rating (Interrupting Capacity) For Groups C & D only

Volt	RMS Symm-Amperes
240	65,000
480	50,000
600	25,000

- CSA Standard: C22.2 No. 30
- NEMA/EEMAC: 3, 3R, 4 \ddagger , 4X $\dagger\dagger$, 7BCD, 9EFG, 12

‡Enclosure not suitable for NEMA 4 or 4X with cover mounted operators.
††With S752 or S753.

Standard Materials:

- Body and cover – copper-free aluminum
- Operating handle – copper-free aluminum
- Operating shafts and bushings – stainless steel
- Cover bolts, hinges, washer and retractile springs – stainless steel
- Interior parts – sheet steel, electrogalvanized

Electrical Rating Range:

- Motor starters – NEMA/EEMAC sizes 0-5
- Circuit breakers – 100, 150, 225, 250, 400, 600, 800, 1000 \dagger ampere frame sizes
- Motor circuit protectors – 150, 250, 400 ampere frame sizes

\dagger 1000 Ampere Frame (max. 800 ampere trip)

Options:

The following options are available from the factory by adding suffix to catalog number – suffixes are added alphanumerically.

Catalog Number System Example

EBMC1FB-①-WT30FDB36-W643-②

①Options in this position are additions to the enclosure itself and should be listed alphanumerically.

②Options in this position are modifications to the starter and/or circuit breaker and should be listed alphanumerically.



EBMC Series motor control enclosures with combination line starters.

When specifying any one of the following options with EBM Motor Controls (J1, J3, PB23, RR2, RR3), it is necessary to order DSL Legend Plates for identification and marking of the device(s) being used.

Description	Position in Cat. #	Suffix
• Ambient compensated circuit breaker trip setting	②	AC
• Less overload relays (lighting contactor).....	①	CL
• Less overload relays (motor contactor).....	①	CM
• Control Circuit Transformer, 100VA for NEMA/EEMAC sizes 0–2, 600/480/240–120, 50 / 60 Hertz, with provision for fusing both primary leads and one secondary lead (fuses not provided)	①	FTPS100
• Control Circuit Transformer, 200VA for NEMA/EEMAC size 3, 600/480/240–120, 50 / 60 Hertz, with provision for fusing both primary leads and one secondary lead (fuses not provided)	①	FTPS200
• Control Circuit Transformer, 300VA for NEMA/EEMAC size 4, 5 600/480/240–120, 50 / 60 Hertz, with provision for fusing both primary leads and one secondary lead (fuses not provided)	①	FTPS300
• Pilot light, 120VAC, red jewel, w/blank indicating plate	①	J1
• Pilot light, 120VAC, green jewel, w/blank indicating plate	①	J3
• LED pilot lights (in place of standard incandescent lamps)	①	LED
• Less heaters in starter overload relay.....	②	0
• Start-Stop pushbuttons (requires 2 spaces).....	①	PB23\ddagger
• On-Off selector switch	①	RR2\ddagger
• Hand-Off-Auto selector switch	①	RR3\ddagger
• Space heater, 120 Volt, 25 Watts	①	R11
• Space heater, 240 Volt, 25 Watts	①	R22
• Space heater, 480 Volt, 25 Watts	①	R44
• Automatic reset overload relay	①	S1
• Insulated neutral w/2 connectors	①	S146
• Std. drain, Class I, B,C & D; Class II, E, F & G; Class III	①	S756\ddagger
• Std. breather & drain, Class I, B,C & D; Class II, E, F & G; Class III	①	S756V\ddagger
• External epoxy finish	①	S752
• Internal and external epoxy finish	①	S753
• Additional control contacts, N.O. or N.C. – for single speed, non-reversing starters only (number limited by design of starter. Details on specific makes and sizes on request.)		
Auxiliary contacts on starter 1 N.O. & 1 N.C.....	②	S781
Auxiliary contacts on starter 2 N.O. & 2 N.C.....	②	S782
Auxiliary contacts on starter 3 N.O. & 3 N.C.....	②	S783
• Auxiliary switch on Circuit Breaker 1A and 1B contacts	②	S784
• Auxiliary switch on Circuit Breaker 2A and 2B contacts	②	S785
• 12 Point term. block – 30 Amp, 300V.....	①	S786
• General purpose control relay, 4 pole N.O., contacts rated 10A@600V, coil 120VAC, 50 / 60 hertz	①	S787*

*Use of this option with NEMA/EEMAC Size 0, or 1 starters necessitates using the larger "D" size enclosure.

\ddagger Enclosure not suitable for NEMA 4 or 4X with cover mounted operators. Breather and drain entries must be plugged for NEMA 4 rating.

$\dagger\dagger$ With S752 or S753.

EBMC Combination Line Starters and Enclosures

Cl. I, Div. 1 & 2, Groups B, C, D
 Cl. II, Div. 1, Groups E, F, G
 Cl. II, Div. 2, Groups F, G
 Cl. III
 NEMA 3, 3R, 4†, 4X††, 7BCD, 9EFG, 12

Explosionproof
 Dust-Ignitionproof
 Raintight
 Wet Locations
 Watertight

1C

Options:

- If desired, markings on indicating plates may be added to catalog number. Select from the list of standard markings below.
- Insert legend plate(s) catalog number (i.e. DSL16) immediately after optional device in the EBM catalog number.
- If EMP devices are to be added in the field, DSL Legend Plates must be ordered separately, as they are not furnished with the EMP/EMPS devices.

Example:

EBMC1FB-0-WT30FDB36-W643-2

Use the charts below to select the appropriate legend plate(s) for your application. Markings shown in **bold print** are etched; all others are stamped.

Single Function Legend Plates

Marking	Cat. #
Automatic	DSL16
Blank	DSL01
Blank with single field	DSL02
Close	DSL21
Down	DSL23
Emerg. Stop	DSL17
Fast	DSL46
Forward	DSL18
Hand	DSL15
In	DSL24
Jog	DSL10
Lower	DSL27
On	DSL07
Off	DSL08
Open	DSL20
Out	DSL25
Power On	DSL14
Raise	DSL26
Reset	DSL12
Reverse	DSL19
Run	DSL09
Safe	DSL85
Slow	DSL47
Start	DSL05
Stop	DSL06
Test	DSL13
Trip	DSL11
Up	DSL22

Two Function Legend Plates

Marking	Cat. #
Blank with 2 fields	DSL03
For-Rev	DSL30
Hand-Auto	DSL29
In-Out	DSL35
Off-On	DSL48
Open-Close	DSL32
Raise-Lower	DSL36
Run-Jog	DSL28
Safe-Run	DSL86
Start-Stop	DSL37
Slow-Fast	DSL65
Up-Down	DSL33

Three Function Legend Plates

Marking	Cat. #
Auto-Off-Hand	DSL49
Blank with 3 fields	DSL04
Fast-Off-Slow	DSL41
For-Off-Rev	DSL40
Hand-Off-Auto	DSL39
Run-Off-Jog	DSL38
Open-Off-Close	DSL43
Raise-Off-Lower	DSL87
Slow-Off-Fast	DSL88
Up-Off-Down	DSL44
1-Off-2	DSL42

Background color for all legend plates is black with the following exceptions:

Marking	Plate Color
Start	Green
Stop	Red
Emerg. Stop	Red

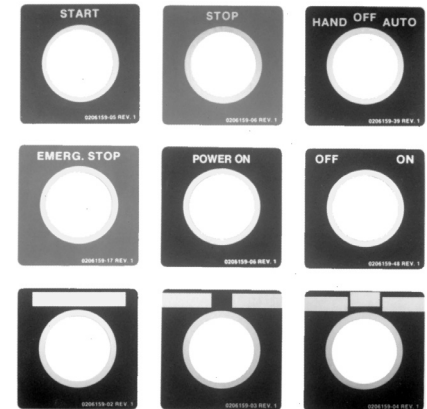

‡Enclosure not suitable for NEMA 4 or 4X with cover mounted operators.
 ††With S752 or S753.

1C

EBMC Combination Line Starters and Enclosures

Dimensions (In inches)†

Cl. I, Div. 1 & 2, Groups B, C, D
 Cl. II, Div. 1, Groups E, F, G
 Cl. II, Div. 2, Groups F, G
 Cl. III
 NEMA 3, 3R, 4‡, 4X††, 7BCD, 9EFG, 12

Explosionproof
 Dust-Ignitionproof
 Raintight
 Wet Locations
 Watertight

Dimensions In Inches:

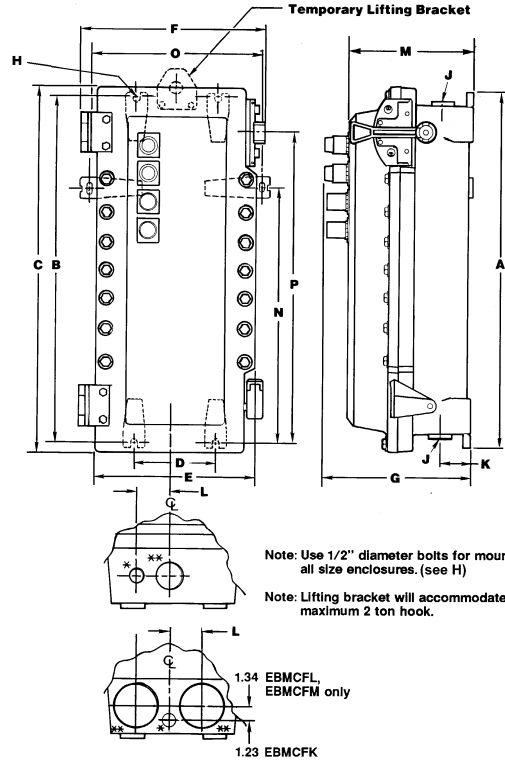

*1" Conduit entrance for control conductors (top & bottom).

**Conduit entrance for power conductors (top & bottom). (All conduit entrances supplied with RE reducer and PLG plug.)

Enclosure Only Cat. #	Enclosure Size Symbol	A	B	C	D	E	F	G	J** Conduit Entry Trade Size D&T⊗	w/RE	K	L	M	N	O	P
Size 0, 1 FVNR combination line starter§																
EBMCFB	B	25.75	24.75	26.90	6.00	13.03	14.78	12.13	2"	1.5"	3.25	3.13	10.25	—	—	22.00
Size 2 FVNR combination line starter																
EBMCFD	D	28.25	27.25	29.40	6.00	13.03	14.67	12.13	3"	2.5"	3.25	3.13	10.25	—	—	24.50
Size 3 FVNR combination line starter																
EBMCFG■	G	38.13	36.50	39.28	6.00	13.03	14.78	12.13	3"	2.5"	3.25	3.13	10.25	—	—	34.06
EBMCFH	H	37.50	36.50	38.65	6.00	14.65	16.65	13.54	3"	2.5"	3.25	3.94	11.66	—	—	33.75
Size 4 FVNR combination line starter																
EBMCFK■	K	43.12	41.50	42.65	12.00	17.65	20.46	12.80	(2) 3"	(2) 2.5"	3.25	3.00	10.78	—	—	19.97
EBMCFL	L	53.47	51.50	53.28	12.00	17.90	20.58	15.00	(2) 4"	(2) 3.5"	4.00	3.50	13.03	41.50	18.40	29.88
Size 5 FVNR combination line starter																
EBMCFM	M	64.22	62.50	64.03	12.00	17.90	21.08	15.00	(2) 4"	(2) 3.5"	4.00	3.50	13.03	41.50	18.40	34.46

†Dimensions are approximate, not for construction purposes.

‡Enclosure not suitable for NEMA 4 or 4X with cover mounted operators.

††With S752 or S753.

§Use EBMCFD enclosure when LVR1 or S787 options are ordered with Size 0 or 1 combination starters.

■For Cutler-Hammer W200 Advantage® starters.

⊗Drilled & Tapped.

EBMC Combination Line Starters and Enclosures

Single-Speed Non-Reversing with Circuit Breakers 3-Pole 60 hertz, 600VAC Maximum

Cl. I, Div. 1 & 2, Groups B, C, D Explosionproof
 Cl. II, Div. 1, Groups E, F, G Dust-Ignitionproof
 Cl. II, Div. 2, Groups F, G Raintight
 Cl. III Wet Locations
 NEMA 3, 3R, 4 \ddagger , 4X $\dagger\dagger$, 7BCD, 9EFG, 12 Watertight

1C

Ordering Information:

To order an enclosure complete with starter and breaker, insert the manufacturer's symbols in the designated positions of the catalog number. Symbols are shown in the footnotes see page 452.

Select the complete Cat. No. below and specify HP, voltage, frequency, RPM, type and full load ampere rating of motor – or specify ampere rating of heaters.

Instantaneous magnetic trip circuit breakers (magnetic circuit interrupters) can be supplied. Consult factory.

Enclosures only can be ordered. Select from listings below.

For Combination starters with motor circuit protectors for single speed, non-reversing motors see page 453.

Motor Starter			Circuit Breaker			Enclosure	
Max. HP Polyphase	Line Volts	NEMA Size	Amp Rating	Frame Volts	Frame Types	Without Breaker & Starter Cat. #	With Breaker & Starter Cat. # §
2	120	0	30	240	TEB	EBMCFB	EBMC0FB ①30②32 ③613
2	120	0	30	480	TED, EHD	EBMCFB	EBMC0FB ①30②34 ③613
2	120	0	30	600	TED, FDB	EBMCFB	EBMC0FB ①30②36 ③613
3	240	0	20	240	TEB	EBMCFB	EBMC0FB ①20②32 ③623
3	240	0	20	480	TED, EHD	EBMCFB	EBMC0FB ①20②34 ③623
3	240	0	20	600	TED, FDB	EBMCFB	EBMC0FB ①20②36 ③623
5	480	0	15	480	TED, EHD	EBMCFB	EBMC0FB ①15②34 ③643
5	480	0	15	600	TED, FDB	EBMCFB	EBMC0FB ①15②36 ③643
5	600	0	15	600	TED, FDB	EBMCFB	EBMC0FB ①15②36 ③663
5	240	1	30	240	TEB	EBMCFB	EBMC1FB ①30②32 ③623
5	240	1	30	480	TED, EHD	EBMCFB	EBMC1FB ①30②34 ③623
5	240	1	30	600	TED, FDB	EBMCFB	EBMC1FB ①30②36 ③623
7½	240	1	50	240	TEB	EBMCFB	EBMC1FB ①50②32 ③623
7½	240	1	50	480	TED, EHD	EBMCFB	EBMC1FB ①50②34 ③623
7½	240	1	50	600	TED, FDB	EBMCFB	EBMC1FB ①50②36 ③623
10	480	1	30	480	TED, EHD	EBMCFB	EBMC1FB ①30②34 ③643
10	480	1	30	600	TED, FDB	EBMCFB	EBMC1FB ①30②36 ③643
10	600	1	30	600	TED, FDB	EBMCFB	EBMC1FB ①30②36 ③663
10	240	2	50	240	TEB	EBMCFD	EBMC2FD ①50②32 ③623
10	240	2	50	480	TED, EHD	EBMCFD	EBMC2FD ①50②34 ③623
10	240	2	50	600	TED, FDB	EBMCFD	EBMC2FD ①50②36 ③623
15	240	2	70	240	TEB	EBMCFD	EBMC2FD ①70②32 ③623
15	240	2	70	480	TED, EHD	EBMCFD	EBMC2FD ①70②34 ③623
15	240	2	70	600	TED, FDB	EBMCFD	EBMC2FD ①70②36 ③623
15	480	2	40	480	TED, EHD	EBMCFD	EBMC2FD ①40②34 ③643
15	480	2	40	600	TED, FDB	EBMCFD	EBMC2FD ①40②36 ③643
15	600	2	40	600	TED, FDB	EBMCFD	EBMC2FD ①40②36 ③663
20	480	2	50	480	TED, EHD	EBMCFD	EBMC2FD ①50②34 ③643
20	480	2	50	600	TED, FDB	EBMCFD	EBMC2FD ①50②36 ③643
20	600	2	50	600	TED, FDB	EBMCFD	EBMC2FD ①50②36 ③663
25	480	2	70	480	TED, EHD	EBMCFD	EBMC2FD ①70②34 ③643
25	480	2	70	600	TED, FDB	EBMCFD	EBMC2FD ①70②36 ③643
25	600	2	70	600	TED, FDB	EBMCFD	EBMC2FD ①70②36 ③663
20	240	3	90	240	TEB	EBMCFH	EBMC3FH ①90②32 ③623
25	240	3	100	240	TEB	EBMCFH	EBMC3FH ①100②32 ③623
30	240	3	125	480	TED	EBMCFH	EBMC3FH ①125②34 ③623
30	480	3	70	480	TED, EHD	EBMCFH	EBMC3FH ①70②34 ③643
30	480	3	70	600	TED, FDB	EBMCFH	EBMC3FH ①70②36 ③643
30	600	3	70	600	TED, FDB	EBMCFH	EBMC3FH ①70②36 ③663

①②③ See page 452 for configurable options.

The standard coil voltage is equal to the line voltage. To include a 120V coil, insert a "1" between the last two characters in the catalog number. The 120V coil is required with the FTFS suffix. Example: EBMC1FB-①30②36-③643 becomes EBMC1FB-①30②36-③6413

‡Enclosure not suitable for NEMA 4 or 4X with cover mounted operators.

††With S752 or S753.

§Starters are furnished with 3 heaters, when heater ratings are fully specified.

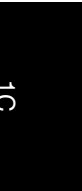

1C EBMC Combination Line Starters and Enclosures

Single-Speed Non-Reversing 3-pole 60 Hertz, 600VAC Maximum

Cl. I, Div. 1 & 2, Groups B, C, D
 Cl. II, Div. 1, Groups E, F, G
 Cl. II, Div. 2, Groups F, G
 Cl. III
 NEMA 3, 3R, 4†, 4X††, 7BCD, 9EFG, 12
 Explosionproof
 Dust-ignitionproof
 Raintight
 Wet Locations
 Watertight

Motor Starter			Circuit Breaker			Enclosure	
Max. HP Polyphase	Line Volts	NEMA Size	Amp Rating	Frame Volts	Frame Types	Without Breaker & Starter Cat. #	With Breaker & Starter Cat. # §
40	480	3	90	480	TED, EHD	EBMCFH	EBMC3FH ①90②34 ③643
40	480	3	90	600	TED, FDB	EBMCFH	EBMC3FH ①90②36 ③643
40	600	3	90	600	TED, FDB	EBMCFH	EBMC3FH ①90②36 ③663
50	480	3	100	480	TED, EHD	EBMCFH	EBMC3FH ①100②34 ③643
50	480	3	100	600	TED, FDB	EBMCFH	EBMC3FH ①100②36 ③643
50	600	3	100	600	TED, FDB	EBMCFH	EBMC3FH ①100②36 ③663
40	240	4	175	600	JD, JDB	EBMCFL	EBMC4FL WT175②36 ③623
50	240	4	200	600	JD, JDB	EBMCFL	EBMC4FL WT200②36 ③623
60	480	4	125	600	JD, JDB	EBMCFL	EBMC4FL ①125②36 ③643
60	600	4	100	600	JD, JDB	EBMCFL	EBMC4FL ①100②36 ③663
75	480	4	150	600	JD, JDB	EBMCFL	EBMC4FL ①150②36 ③643
75	600	4	125	600	JD, JDB	EBMCFL	EBMC4FL ①125②36 ③663
100	480	4	200	600	JD, JDB	EBMCFL	EBMC4FL WT200②36 ③643
100	600	4	150	600	JD, JDB	EBMCFL	EBMC4FL ①150②36 ③663
125	480	5	300	600	KD, KDB	EBMCFM	EBMC5FM WT300②36 ③643
150	480	5	400	600	KD, KDB	EBMCFM	EBMC5FM WT400②36 ③643

Motor Starter			Fusible Disconnect Switch			With Disconnect Switch & Starter Cat. #
Max. HP Polyphase	Max. Line Volts	NEMA Size	Amp Rating	Max. Volts	Switch Type	
5	600	0	30	600	DS161R	EBMCOFD WFD30J36 W643
10	600	1	30	600	DS161R	EBMC1FD WFD30J36 W643
25	600	2	60	600	DS262R	EBMC2FD WFD60J36 W643
30	600	3	100	600	DS363R	EBMC3FH WFD100J36 W643

①Circuit Breakers:

Manufacturer	Symbol
Cutler-Hammer	WT
General Electric	TT

NEMA

Size	Without Switch & Starter Cat. #
0	EBMCFD FD
1	EBMCFD FD
2	EBMCFD FD
3	EBMCFH FD

②Select Circuit Breaker Frame Type based on Frame Size, Voltage, and Manufacturer desired:

Manufacturer	100 Amp. Frame and 150 Amp. Frame			250 Amp. Frame 600VAC	400 Amp. Frame 600VAC	600 Amp. Frame 600VAC	800 Amp. Frame 600VAC
	240V AC	480V AC	600V AC				
Cutler-Hammer	—	EHD	FDB HFD♣	JD☆ JDB♣ HJD♣	KD☆ KDB♣ HKD★	LD HLD★	MD
General Electric	TEB	TED	TED				

☆—Interchangeable Trip Unit

♣—Non-Interchangeable Trip Unit

♣—Cutler-Hammer HFD and HJD are rated at 65 kAIC at 480V and 25 kAIC at 600V.

★—Cutler-Hammer HKD and HLD are rated at 65 kAIC at 480V and 35 kAIC at 600V.

③Motor Starters:

Manufacturer	Symbol
Allen Bradley	AB
Square D	D
General Electric	G
Cutler-Hammer	W

‡Enclosure not suitable for NEMA 4 or 4X with cover mounted operators.

††With S752 or S753.

§Starters are furnished with 3 heaters, when heater ratings are fully specified.

EBMC Combination Line Starters

Single-Speed Non-Reversing with Motor
Circuit Protectors
3-pole 60 Hertz, 600VAC Maximum

Cl. I, Div. 1 & 2, Groups B, C, D
Cl. II, Div. 1, Groups E, F, G
Cl. II, Div. 2, Groups F, G
Cl. III
NEMA 3, 3R, 4†, 4X††,
7BCD, 9EFG, 12

Explosionproof
Dust-ignitionproof
Raintight
Wet Locations
Watertight

1C

Ordering Information:

Select the complete Catalog No. below and specify HP, voltage, frequency, RPM, type and full load ampere rating of motors or specify ampere rating of heaters.

Motor Starter					
Max. HP Polyphase	Volts	NEMA Size	MCP Amp Rating	Enclosure without Starter & MCP Cat. #	Enclosure with Starter & MCP Cat. # §
3	240	0	15	EBMCFB	EBMC0FB WP15AHMCP36 ③623
3	480	0	7	EBMCFB	EBMC0FB WP7AHMCP36 ③643
3	600	0	7	EBMCFB	EBMC0FB WP7AHMCP36 ③663
5	480	0	15	EBMCFB	EBMC0FB WP15AHMCP36 ③643
5	600	0	15	EBMCFB	EBMC0FB WP15AHMCP36 ③663
<hr/>					
7½	240	1	30	EBMCFB	EBMC1FB WP30AHMCP36 ③623
7½	480	1	15	EBMCFB	EBMC1FB WP15AHMCP36 ③643
10	480	1	30	EBMCFB	EBMC1FB WP30AHMCP36 ③643
10	600	1	15	EBMCFB	EBMC1FB WP15AHMCP36 ③663
<hr/>					
10	240	2	50	EBMCFD	EBMC2FD WP50BHMCP36 ③623
15	240	2	100	EBMCFD	EBMC2FD WP100BHMCP36 ③623
15	480	2	30	EBMCFD	EBMC2FD WP30AHMCP36 ③643
20	600	2	30	EBMCFD	EBMC2FD WP30AHMCP36 ③663
25	480	2	50	EBMCFD	EBMC2FD WP50BHMCP36 ③643
25	600	2	50	EBMCFD	EBMC2FD WP50BHMCP36 ③663
<hr/>					
30	240	3	100	EBMCFH	EBMC3FH WP100BHMCP36 ③623
30	600	3	50	EBMCFH	EBMC3FH WP50BHMCP36 ③663
50	480	3	100	EBMCFH	EBMC3FH WP100BHMCP36 ③643
50	600	3	100	EBMCFH	EBMC3FH WP100BHMCP36 ③663
<hr/>					
50	240	4	250	EBMCFL	EBMC4FL WP250JHMCP36 ③623
100	480	4	250	EBMCFL	EBMC4FL WP250JHMCP36 ③643
100	600	4	250	EBMCFL	EBMC4FL WP250JHMCP36 ③663
<hr/>					
60	240	5	250	EBMCFM	EBMC5FM WP250JHMCP36 ③623
100	240	5	400	EBMCFM	EBMC5FM WP400GHMCP36 ③623
125	480	5	250	EBMCFM	EBMC5FM WP250JHMCP36 ③643
150	600	5	250	EBMCFM	EBMC5FM WP250JHMCP36 ③663
200	480	5	400	EBMCFM	EBMC5FM WP400GHMCP36 ③643
200	600	5	400	EBMCFM	EBMC5FM WP400GHMCP36 ③663

Motor Circuit Protectors:

Manufacturer	Symbol
Cutler-Hammer	WP

Motor Circuit Protector Frame Type based on Frame Size and Manufacturer desired:

	150 Amp. Frame	250 Amp. Frame	400 Amp. Frame
Cutler-Hammer	HMCP (F-Frame)	HMCP (J-Frame)	HMCP (K-Frame)

MCP Amp Rating	Symbol	Trip Range
Cutler-Hammer (WP)		
7	A	21 to 70
15	A	45 to 150
30	A	90 to 300
50	B	150 to 500
100	B	300 to 1000
250	J	1250 to 2500
400	G	1250 to 2500

Consult factory for other trip ranges available.

③Motor Starters:

Manufacturer	Symbol
Allen Bradley	AB
Square D	D
General Electric	G
Cutler-Hammer	W

† Enclosure not suitable for NEMA 4 or 4X with cover mounted operators.

††With S752 or S753.

§Starters are furnished with three heaters when heater ratings are fully specified.