

# D2PB Division 2 Circuit Breaker Panelboards

Cl. I, Div. 2, Groups C, D  
NEMA 3, 7CD (Div. 2), 12  
Dust-tight  
Raintight

Wet Locations

1A

## Factory Sealed, Single & Two-Pole Circuit Breakers

### Applications:

D2PB panelboards are designed specifically for use:

- In Class I, Division 2, Groups C, D hazardous areas where flammable vapors or gases may be present due to accident or abnormal locations
- In damp, wet or corrosive locations
- Indoors or outdoors in Division 2 areas of petroleum refineries, chemical and petrochemical plants, and other process industry facilities

For general application, circuit breaker and wiring system information, see pages 626–629.

### Features:

- Enclosures are of external flange design, which makes the interior completely accessible when the cover is removed
- Provided with concealed mounting, which is made possible by having four clearance holes for lag screws or mounting bolts in the back of the enclosure, one in each corner
- The interior sub-assembly, consisting of a mounting plate, main terminal blocks, and circuit breakers, is removable as a complete unit
- Ample gutter space is provided for ease of field wiring
- Circuit breakers are contained in compact, individual factory sealed enclosures suitable for Class I, Division 2, Groups C, D hazardous areas. The individual enclosures are easily removed and replaced, therefore changing or adding individual circuit breakers will not present a problem
- The main cover, which is gasketed to exclude dirt and moisture, is attached to the body with hex head bolts and is removed only when installing the panelboard or making wiring changes. In the center of the main cover is a gasketed hinged door, which provides access only to the circuit breaker operating handles, and is held closed by two quick release catches. The door can be locked by as many as 3 padlocks to prevent unauthorized operation
- Tapped conduit openings are provided for main conduit and branch circuits, as shown in the dimensional information. Standard openings can be reduced or plugged to meet most installation requirements
- Circuit breakers are arranged in two vertical rows and have the circuit numbers marked on the handles. The left row is numbered 1, 3, 5, 7, etc. and the right row 2, 4, 6, 8, etc. Identifying information may be typed on the circuit directory card attached to the inside of the hinged door

### Certifications and Compliances:

- NEC: Class I, Division 2, Groups C, D
- NEMA: 3, 7CD (Division 2), 12
- UL Standard: 67, 877

### Standard Materials:

- Bodies, covers and hinged doors – copper-free aluminum
- Breaker operating handles – type 6 / 6 nylon
- Interior parts – sheet steel

### Standard Finishes:

- Copper-free aluminum – natural
- Type 6 / 6 nylon – natural (black)
- Sheet steel – electrogalvanized with chromate finish

### Options:

#### Description:

- Panelboard provided with operating handle lockouts for lockout in ON or OFF positions. Stainless steel lockout frame integral to panel faceplate.  
D2PB Size 1..... L12  
D2PB Size 2..... L24
- Branch conduit entries furnished with Eaton's Crouse-Hinds type PLG plugs..... S822
- Square head plugs in all openings.... S872
- Branch circuit conduit openings located at bottom instead of at top.. INV
- Drilled and tapped conduit openings other than standard – available on special order – specify.. I
- Breather and drain..... DV
- Circuit breaker operating handle lockout - order D2PB02
- Assortment of single-pole and two-pole circuit breakers and trip ratings – see listings.

Wiring system other than those listed – See page 628

#### Suffix:

#### Specify

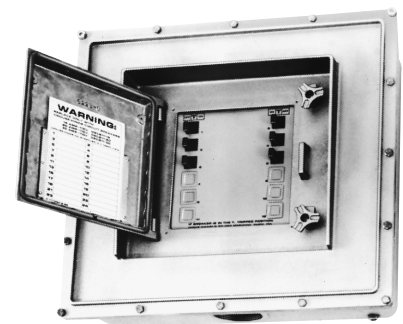
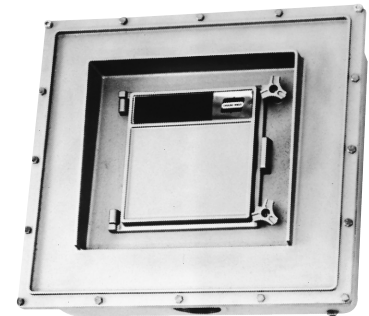

### Size Ranges:

Panel Size	Max. No. of Breakers	
	Single-Pole	Two-Pole
1	12	6
2	24	12

### Electrical Rating Ranges:

- Circuit breakers
- Single-pole – 120/240VAC max.
- Two-pole – 120/240VAC max.
- Trip ratings – 15, 20 and 30 amp

### Dimensions In Inches:

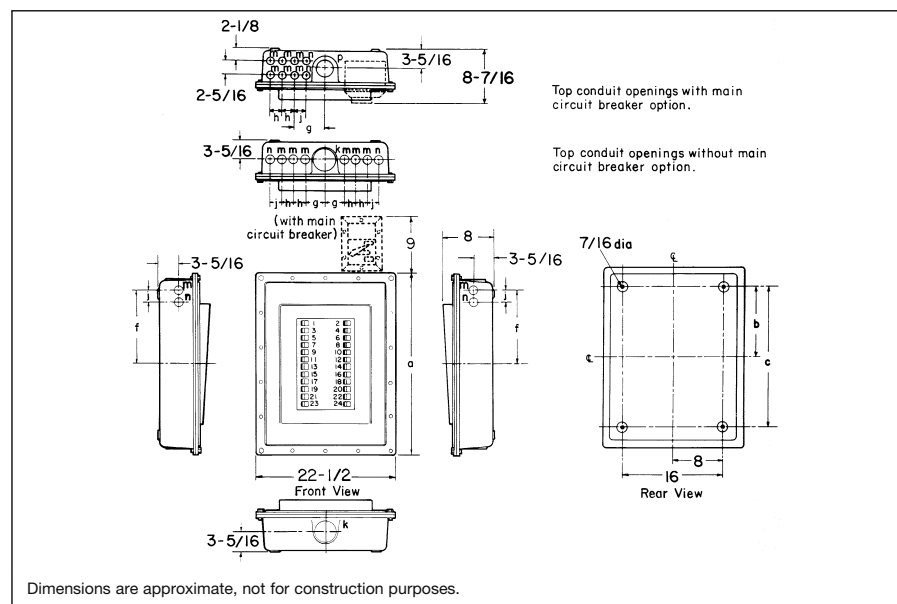

# 1A D2PB Division 2 Circuit Breaker Panelboards

Factory Sealed, Single & Two-Pole Circuit Breakers

Cl. I, Div. 2, Groups C, D  
NEMA 3, 7CD (Div. 2), 12  
Dust-tight  
Raintight

Wet Locations

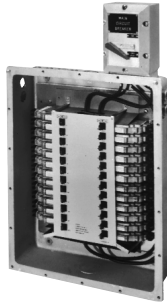

D2PB with Main Breaker Option

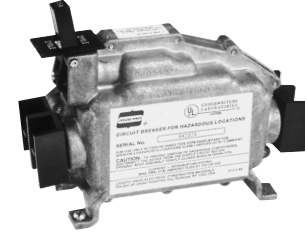

D2CB12-20

## Replacement Circuit Breaker Assemblies

Where D2PB (and N2PB) panelboards have been ordered with less than the maximum number of circuit breakers, breakers can easily be added in the field. Circuit breaker assemblies for field addition or replacement are listed below; they consist of the breaker itself in its factory sealed Class I, Division 2, Groups C, D enclosure, and necessary mounting hardware. These assemblies are not suitable for use as individually mounted units.

### Circuit Breaker Assemblies

Ampere Rating	Single-Pole Cat. #	Two-Pole Cat. #
15	D2CB11 15	D2CB12 15
20	D2CB11 20	D2CB12 20
30	D2CB11 30	D2CB12 30

## Ordering Information:

Panelboards are available with single-pole and two-pole, 15, 20, or 30 ampere circuit breakers. To order a panelboard with all breakers of the same rating, add the desired rating as a suffix to the Cat. No. For example, the 12 circuit D2PB1512 panelboard with all the circuit breakers rated at 20 amperes would be ordered as D2PB1512-20.

Panelboards shown below can also be furnished with an assortment of single-pole and two-pole breakers and breaker ampere ratings. To order, the quantities of breakers and ampere ratings are added as a suffix to the Cat. No. The total number of poles will determine the panel size (24 poles maximum), and the wiring systems must be compatible when combining single- and two-pole circuit breakers. For example, a typical D2PB panelboard with a combination of 3 single-pole 15 ampere, 3 single-pole 20 ampere, 2 single-pole 30 ampere, 4 two-pole 20 ampere, and 4 two-pole 30 ampere circuit breakers would be ordered as D2PB2508-315-320-230-808-420-430. The total number of poles is 24 and wiring systems 5 and 8 are compatible 4 wire, 3 phase.

The D2PB with a main breaker is available up to 100 amps. To order D2PB with main breaker, add the appropriate suffix. Example: D2PB1512-15 with three-pole, 100 amp main circuit breaker would be ordered as D2PB1512-15-3M100. If two-pole main is required, change the number 3 to 2. If a lower trip rating than 100 is required, the suffix will change accordingly.

Max. No. of Breakers				Single-Pole Circuit Breakers		Two-Pole Circuit Breakers	
Single-Pole	Two-Pole	Panel Size	Main Lug Size†	Wiring System 4*	Wiring System 5*	Wiring System 3*	Wiring System 8*
				Mains: 3-Wire Branches: 2-Wire Solid Neutral Cat. #	Mains: 4-Wire, 3-Phase Branches: 2-Wire Solid Neutral Cat. #	Mains: 3-Wire Branches: 3-Wire Solid Neutral Cat. #	Mains: 4-Wire, 3-Phase Branches: 3-Wire, 1-Phase Solid Neutral Cat. #
6				D2PB1406 ①	D2PB1506 ①		
8	4	1	1 / 0	D2PB1408 ①	D2PB1508 ①	D2PB1304 ①	D2PB1804 ①
10	5			D2PB1410 ①	D2PB1510 ①	D2PB1305 ①	D2PB1805 ①
12	6			D2PB1412 ①	D2PB1512 ①	D2PB1306 ①	D2PB1806 ①
12	6			D2PB2412 ①	D2PB2512 ①	D2PB2306 ①	D2PB2806 ①
14	7			D2PB2414 ①	D2PB2514 ①	D2PB2307 ①	D2PB2807 ①
16	8			D2PB2416 ①	D2PB2516 ①	D2PB2308 ①	D2PB2808 ①
18	9	2	4 / 0	D2PB2418 ①	D2PB2518 ①	D2PB2309 ①	D2PB2809 ①
20	10			D2PB2420 ①	D2PB2520 ①	D2PB2310 ①	D2PB2810 ①
22	11			D2PB2422 ①	D2PB2522 ①	D2PB2311 ①	D2PB2811 ①
24	12			D2PB2424 ①	D2PB2524 ①	D2PB2312 ①	D2PB2812 ①

①Add ampere rating. See ordering information.

†1/0 lug, rated 125 amps. takes wire sizes #6 to 1/2; 1/2 lug, rated 225 amps. takes wires sizes 1/2 to 3/4.

\*For description of these standard wiring systems, see page 628.

## Dimensions

	Overall and Mounting Dimensions (In.)			Conduit Openings Spacing (In.)				Size (In.)				Quantity		
	a	b	c	f	g	h	j	k	m	n⊕	p	Main	Branches	
<b>Panel Size Without Main C.B.</b>														
1	20 3/4	8	16	7 3/4	3 1/2	2		3	1 1/4			2	8	
2	28 3/4	11 3/4	23 1/2	11 3/8	3 1/16	1 15/16	1 15/16	3	1 1/4	1 1/4		2	12	
<b>Panel Size With Main C.B.</b>														
1	20 3/4	8	16	7 3/4	5	1 15/16			1 1/4		2 1/2	2	8	
2	28 3/4	11 3/4	23 1/2	11 3/8	5	1 15/16	1 15/16		1 1/4	1 1/4	2 1/2	2	12	

⊕Conduit opening "n" not supplied on panel size 1.

# D2PB, D2L, D2D Circuit Breaker Panelboard Assemblies

## with Transformer

Cl. I, Div. 2, Groups B†, C, D  
NEMA 3, 4‡, 7B†CD (Div. 2), 12  
Wet Locations  
Watertight‡

1A

### Applications:

D2PB, D2L, D2D circuit breaker panelboard assemblies with transformers are for use:

- In Class I, Division 2, Group C, D hazardous areas where, due to accident or abnormal operations, flammable vapors or gases may be present, and which are subject to weather, dampness and corrosion
- Indoors or outdoors in Division 2 areas such as petroleum refineries, chemical and petrochemical plants, and other process industry facilities
- Where high voltage supply must be stepped down to the lower voltage necessary to serve lighting, heating, appliance, heat tracing, motor and similar circuits

For general information on panelboard applications, circuit breakers and wiring systems, see pages 626–629.

### Features:

- The factory assembled panelboard and transformer are on one compact frame, suitable for either wall or pole mounting. Wiring between the transformer secondary and main lugs of the panelboard is accomplished at the factory.
- Easy to install and wire. The main feed is connected to the transformer primary and the branch circuits are wired to the panelboard terminal blocks.
- The assembly can be installed in the load area to reduce the length of runs of low voltage branch circuits.
- Panelboards used are standard D2PB, D2L, or D2D units with circuit breakers listed in this section.
- Transformers are compound filled or epoxy filled to completely seal out moisture and dirt.

### Certifications and Compliances:

- NEC/CEC:  
Class I, Division 2, Group B†, C, D
- NEMA/EEMAC: 3, 4‡, 7B†CD (Division 2), 12
- UL Standard: 67, 1604
- CSA Standard: C22.2 No. 213

### Standard Materials:

- Frames – structural aluminum
- Mounting hardware – stainless steel
- Transformer enclosure – sheet steel, welded
- For panelboard materials, see individual listing pages

### Standard Finishes:

- Aluminum – natural
- Stainless steel – natural
- Sheet steel – primed and painted
- For panelboard finishes, see individual listing pages

### Options:

- Material – structural steel frames
- Finish – primed and painted or hot dip galvanized
- For options available on the panelboards themselves, see individual listings pages

### Size Ranges:

#### Transformers

Single or three-phase – 5kVA to 30kVA

#### Panelboards

	Max. No. of Breakers		
	Single-pole	Two-pole	Three-pole
D2PB	24	12	
D2L	42	20	14
D2D	30	14	10

### Electrical Rating Ranges:

- Transformers – 480 volt primary
- Transformers – 120 / 240 volt secondary
- Panelboards – see individual listings

† D2L, D2D with GB suffix and breather and drain holes plugged.  
‡ NEMA 4 hoesetight with breather and drain openings plugged.

# 1A D2PB, D2L, D2D Circuit Breaker Panelboard Assemblies with Transformer

Cl. I, Div. 2, Groups B†, C, D  
 NEMA 3, 4‡, 7B†CD (Div. 2), 12  
 Wet Locations  
 Watertight‡

## Typical Assembly\* 24 Circuit D2PB panelboard with single-phase transformer

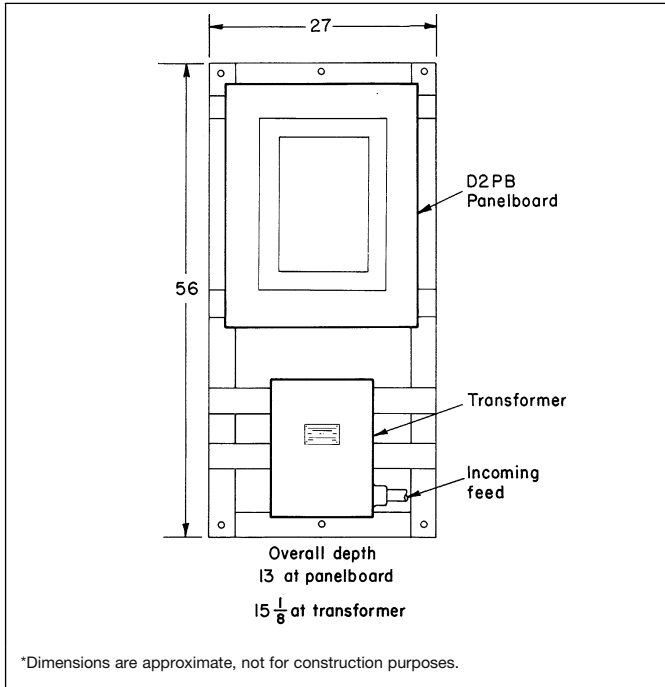

## Ordering Check List

- Select the D2PB, D2L, D2D panelboard required, together with any applicable options or special features. See individual listing pages.  
 Cat. No. \_\_\_\_\_
- Provide the following information, necessary for selection of the correct transformer:  
 Primary voltage \_\_\_\_\_  
 Secondary voltage \_\_\_\_\_  
 kVA rating \_\_\_\_\_  
 Taps - number and percent \_\_\_\_\_  
 Frequency (60 cycle unless otherwise specified) \_\_\_\_\_  
 Single or three-phase \_\_\_\_\_  
 Other requirements \_\_\_\_\_

1A

† D2L, D2D with GB suffix and breather and drain holes plugged.  
 ‡ NEMA 4 hoesetight with breather and drain openings plugged.